

# Multimedia Traffic over Wireless and Satellite Networks

Floriano De Rango, Mauro Tropea and Peppino Fazio  
*DEIS Dept., University of Calabria,  
Italy*

## 1. Introduction

The rapid growth of multimedia application together with advanced development in digital technology and with the increased use of mobile terminal has pushed the research toward new network technologies and standards for wireless environment. Moreover, ever-increasing computing power, memory, and high-end graphic functionalities have accelerated the development of new and exciting wireless services. Personal video recorders, video on demand, multiplication of program offerings, interactivity, mobile telephony, and media streaming have enabled viewers to personalize the content they want to watch and express their preferences to broadcasters. Viewers can now watch television at home or in a vehicle during transit using various kinds of handheld terminals, including mobile phones, laptops computers, and in-car devices. The concept of providing television-like services on a handheld device has generated much enthusiasm. Mobile telecom operators are already providing video-streaming services using their third-generation cellular networks. Simultaneous delivery of large amounts of consumer multimedia content to vast numbers of wireless devices is technically feasible over today's existing networks, such as third-generation (3G) networks. As conventional analog television services end, broadcasters will exploit the capacity and flexibility offered by digital systems. Broadcasters will provide quality improvements, such as high-definition television (HDTV), which offer many more interactive features and permit robust reception to receivers on the move in vehicles and portable handhelds. Mobile TV systems deliver a rich variety of content choice to consumers while efficiently utilizing spectrum as well as effectively managing capital and operating expenses for the service provider. Mobile TV standards support efficient and economical distribution of the same multimedia content to millions of wireless subscribers simultaneously. Mobile TV standards reduce the cost of delivering multimedia content and enhance the user experience, allowing consumers to surf channels of content on a mobile receiver. Mobile TV standards address key challenges involved in the wireless delivery of multimedia content to mass consumers and offer better performance for mobility and spectral efficiency with minimal power consumption. An important aspect of multimedia delivery contest is the possibility of make integration between different networks in order to be able of reaching users every-time every-where. Then, it is possible to use a multi-layer hierarchic platform that use satellite [1] segment together with wireless network based on 802.11 standard [2,3,4] and with cellular network in order to have an ubiquitous coverage. In

Source: Digital Video, Book edited by: Floriano De Rango,  
ISBN 978-953-7619-70-1, pp. 500, February 2010, INTECH, Croatia, downloaded from SCIYO.COM

order to grapple with the continuously increasing demand on multimedia traffic over high speed wireless broadband networks it is also necessary to make network able to deal with the QoS constraints required by users. In order to provide quality of service to user applications, networks need optimal and optimized scheduling and connection admission control algorithm. These mechanisms help to manage multimedia traffic guaranteeing QoS to calls already admitted in the system and providing QoS to the new connection. In order to evaluate the quality of video traffic with the mobility it is important to examining the quality assessment techniques: Subjective and Objective quality assessment.

## 2. Video quality in multimedia broadcasting

In the last few years multimedia applications are grew very fast in all networks typologies and in particular in wireless networks that are acquiring a big market slice in the telecommunication field. This trend of applications has pushed the researchers to perform a lot of studies in the video applications and in particular in the compression field in order to be able of transporting this information in the network with a low impact in the system resources. In literature a lot of studies exist on video compression and new standard of compression are proposed in order to be able to transmit video traffic on different network technologies that often have resource problem in terms of bandwidth capacity and, then, a very performance compression algorithm can give a great support to network service provider in respecting the quality constrains otherwise nor achievable.

The ubiquitous nature of all multimedia services and their use in overall telecommunications networks requires the integration of a lot of technologies that aim to improve the quality of the applications received by the users. First of all, it is clear that the traditional concept of best effort paradigm in the delivery of multimedia contents is not possible to adopt because it does not match with the users requirements. This type of approach try to do its best but it is unable of guaranteeing any form of users requirements. In order to address this type of problem, recently different Quality of Services architectures have been proposed capable of guaranteeing to the multimedia streams the users constrains. The most famous architectures are Integrated Services and Differentiated Services that manage different class of services in order to allow a traffic differentiation able to discriminate also a cost differentiation for the customers. It is easy to understand that this new type of applications is based on a constantly reliable reception of information that it is possible to have only through an appropriate network management.

The new end users are always more quality aware and then they are more exigent and accordingly networks have to guarantee always more capacity in order to satisfy their users. As a consequence, there is a continuous and extensive research effort, by both industry and academia, to find solutions for improving the quality of multimedia content delivered to the users; as well, international standards bodies, such as the International Telecommunication Union (ITU), are renewing their effort on the standardization of multimedia technologies. There are very different directions in which research has attempted to find solutions in order to improve the quality of the rich media content delivered over various network types [5,6,7,8,9].

Moreover, it is very important to determine efficient quality assessment. It is really important to know how the network behaves in terms of parameters of service for end users in order to take the correct decisions during the development, evaluation, construction and operation of network services.

Over the years have developed many models, more efficient and less expensive, able to consider more types of factors involved in the telecommunication networks. An overview of models of measurement is reported in the Figure 1 below. They are divided substantially in two categories: subjective assessment and objective assessment.

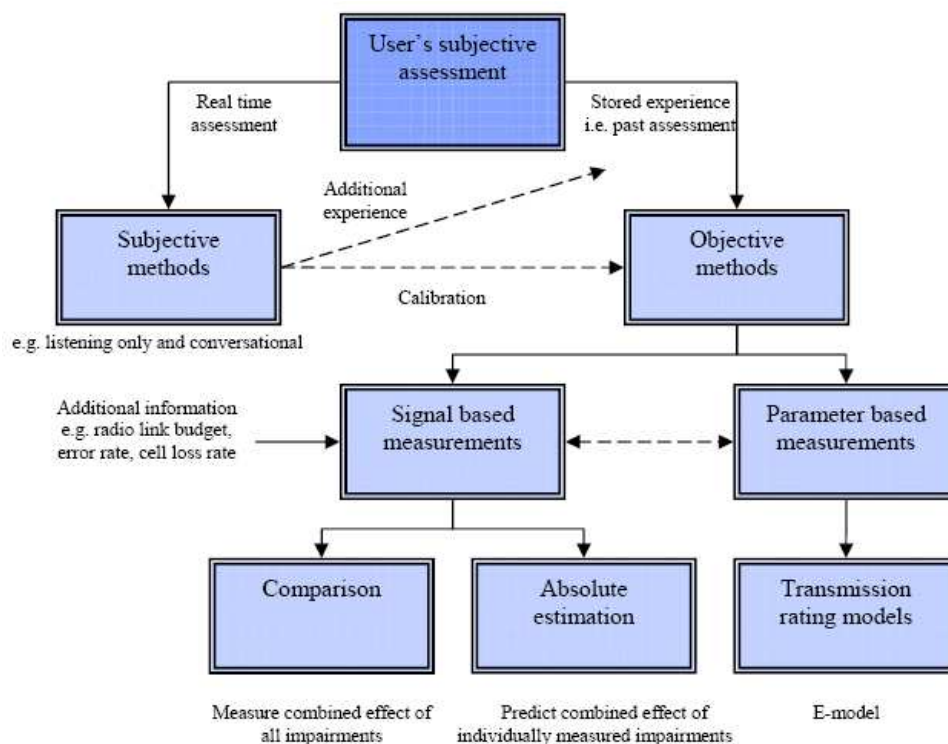

Fig. 1. Overview of models of measurement

## 2.1 Subjective quality assessment

A method to perform quality evaluation for multimedia applications is called subjective assessment and it represents an accurate technique for obtaining quality ratings. It is basically based on experience done by a number of users. Typically, the experiments are made in a room where there are a certain number of persons (about 15-30) that they have to watch a set of video streams and, then, they have to give a rate based on own quality perception. On the basis of all rates given by all subjects included in the experiment it is formulated an average rate called Mean Opinion Score (MOS). It is clear that, being a subjective evaluation determined by the subjectivity and variability of the involved persons, this test is affected by the personal opinion that cannot be eliminated. In order to avoid this type of problem the experiments are made through precise instructions that give to the subject a set of precautions that they have to follow. Moreover, also the environment used for the test is a controlled environment. In this way it is possible to perform a set of tests and provide a quality score that is a number that results from a statistical distribution. There are

a wide variety of subjective testing methods. In literature different methods exist for giving a measure of the perceptual performance of subjects. The ITU has formalized a series of conditions that are used for quality assessment in various recommendations [10,11,12,13,14]. They suggest standard viewing conditions, criteria for the selection of observers and test material, assessment procedures, and data analysis methods. Recommended testing procedures exist as Absolute Category Rating (ACR), Degradation Category Rating (DCR), Comparison Category Rating (CCR).

In the test the presentation order of the video clips can be randomized between viewers in order to obtain a more realistic statistical score. After each video presentation, viewers are asked to judge its overall quality using the rating scale shown in Figure 2.

The image shows a graphical user interface for a subjective assessment rating scale. It consists of five rectangular buttons arranged vertically on the left side, labeled 'Excellent', 'Good', 'Fair', 'Poor', and 'Bad' from top to bottom. To the right of this vertical stack is a single rectangular button labeled 'OK'. All buttons have a light gray background and a thin black border.

Fig. 2. Subjective assessment rating scale

Normally voting period was not time-limited. After choosing their quality rating, assessors had to confirm their choice using an 'OK' button. Furthermore, this eliminated the possibility of missing ratings in the test. After each video sequence and after to have gave a vote, a neutral gray background is, often, displayed on the video terminal during some second before the next sequence is presented. The test procedure and monitor selection adhered to the latest findings and recommendations for best practice from the Video Quality Experts Group (VQEG), a technical body supporting ITU standardization activities.

The use of this type of test has some disadvantages, first of all, the result of the test depend from uncontrollable attributes like experience, the mood, the attitude and culture, then, they are very expensive and impractical if you want to do frequently because of the number of subjects and tests are necessary to give reliable results. Anyway, subjective assessment are invaluable tools for evaluating multimedia quality. Their main shortcoming is the requirement for a large number of viewers, which limits the amount of video material that can be rated in a reasonable amount of time. Nonetheless, subjective experiments remain the benchmark for any objective quality metric.

## 2.2 Objective quality assessment

The subjective methods are not feasible during the design of a network. These are limited, impractical and very expensive. To overcome these problems have been developed, new methods that allow the calculation of values that represent the different combinations of

factors of damage that could affect the network. The primary purpose of these methods is to produce an estimate of quality, providing the results as comparable as possible to MOS values. The ITU is proposing a method of objective testing, automatic and repeatable, which takes into account the perceived quality. Different types of objective metrics exist [15]. For the analysis of decoded video, we can distinguish data metrics, which measure the fidelity of the signal without considering its content, and picture metrics, which treat the video data as the visual information that it contains. For compressed video delivery over packet networks, there are also packet- or bitstream-based metrics, which look at the packet header information and the encoded bitstream directly without fully decoding the video. Furthermore, metrics can be classified into full-reference, no-reference and reduced-reference metrics based on the amount of reference information they require.

The most known video quality metric is called Peak Signal to Noise Ratio (PSNR) that is calculated simply as mathematical difference between every pixel of the encoded video and the original video. The other popular metric is the classical Mean Square Error (MSE) is one of many ways to quantify the amount by which an estimator differs from the true value of the quantity being estimated.

### 3. Multimedia over wireless networks

Nowadays multimedia communication over wireless and wired packet based networks is growing up. In the past, many applications were used for video downloads, while now they take up the share of all traffic on the Internet. Most mobile devices can actively download and upload photos and videos, sometimes in real time. In addition, Voice over IP (VoIP) is heavily changing the voice telecommunications world and the enhanced television is also being delivered into the houses over IP networks by Digital Subscriber Line (DSL) technologies. Another issue in the multimedia revolution takes place inside the home environment: the electronics manufacturers, the computer industry and its partners are distributing audio and video over local-WiFi networks to monitors and speakers around the house. Now that the analog-to-digital revolution is going to be complete, the "all media over IP" revolution is taking place, with radio, television, telephony and stored media all being delivered over IP wired and wireless networks. Figure 3 shows an example of different multimedia applications in a home environment.

The growing and the emergence of communication infrastructures, like the Internet and wireless networks, enabled the proliferation of the above mentioned multimedia applications (music download to a portable device, watching TV through the Internet on a laptop, viewing movie trailers posted on the web through a wireless link). New applications are surely revolutionary, like sending VoIP to an apparently conventional telephone, sending television over IP to an apparently conventional set top box or sending music over WiFi to an apparently conventional stereo amplifier. The exposed applications include a big variety of new multimedia related services but, unfortunately, the Internet and the wireless networks do not provide full support for multimedia applications. The Internet and wireless networks have stochastic and variable conditions influenced by many factors, however variations in network conditions can have heavy consequences for real-time multimedia applications and can lead to unacceptable user experience, because multimedia transmissions are usually delay sensitive, bandwidth intense and loss tolerant. The theory that has traditionally been taught in information theory, communication and signal processing may not be directly applied to highly time-varying channel conditions and, as a

consequence, in recent years the area of multimedia communication and networking has emerged not only as a very active and challenging research topic, but also as an area that requires the definition of new fundamental concepts and algorithms that differ from those taught in conventional signal processing and communication theory.

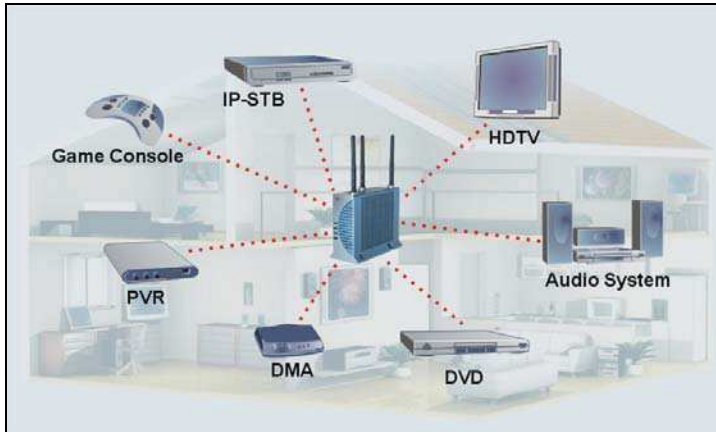

Fig. 3. Different Wireless IP-based multimedia applications (STP – Set Top Box for on-demand video, HDTV – High Definition TV, DMA – Digital Media Adapter for multimedia home extensions, PVR – Personal Video Recorder, etc.).

It is clear that Best-Effort (BE) IP networks are unreliable and unpredictable, especially in wireless networks, where there can be many factors that affect the Quality of Service (QoS), that measures the performance of a transmission system via parameters that reflect its transmission quality, such as delay, loss and jitter. In addition, congested network conditions result in lost video packets, which, as a consequence, produces poor quality video. Further, there are strict delay constraints imposed by streamed multimedia traffic. If a video packet does not arrive before its "playout time", the packet is effectively lost. Packet losses have a particularly devastating effect on the smooth continuous playout of a video sequence, due to inter-frame dependencies. A slightly degraded quality but uncorrupted video stream is less irritating to the user than a corrupted stream. Controlled video quality adaptation is needed to reduce the negative effects of congestion on the stream whilst providing the highest possible level of service and quality. The applications based on streaming operations are able to split the media into separate packets, which are transmitted independently in the network, so that the receiver is able to decode and play back the parts of the bit stream that are already received. The transmitter continues to send multimedia data packets while the receiver decodes and simultaneously plays back other already received parts of the bit stream.

The philosophy of playing back received packets allows the reduction of the delay between the transmission time instant and the moment at which the user views the multimedia content. Having a low delay is of primary importance in such kind of systems, where interactive applications are dominant (for example, a video conference or a video on-demand architecture).

The transmission of multimedia content can be categorized into three main classes: unicast, multicast and broadcast, depending on the number of senders and receivers. Unicast

transmission connects one sender to one receiver (point-to-point connection, p2p), as downloading, on-demand streaming media and p2p telephony. The main advantage of unicast is that a feedback channel can be established between the receiver and the transmitter, so the receiver can return information to the sender about the channel conditions which can be used accordingly by the transmitter to change transmission parameters. In a multicast communication the sender is connected to multiple receivers that decide to join the multicast group; multicast is more efficient than multiple unicast flows in terms of network resource utilization, since the information must not be replicated in the middle nodes (it is obvious that in a multicast communication the sender cannot open a session toward a specific receiver). In a broadcast transmission, the sender is connected to all receivers that it can reach through the network (an example is a satellite transmission); the communication channel may be different for every receiver.

One possible approach to the problem of network congestion and resulting packet loss and delay is to use feedback mechanisms to adapt the output bit rate of the encoders, which, in turn adapts the video quality, based on implicit or explicit information received about the state of the network. Several bit rate control mechanisms based on feedback have been presented in the last few years. As the Real-Time Control Protocol (RTCP) provides network-level QoS monitoring and congestion control information such as packet loss, round trip delay, and jitter. Many applications use RTCP to provide control mechanisms for transmission of video over IP networks. However, the network-level QoS parameters provided by RTCP are not video content-based and it is difficult to gauge the quality of the received video stream from this feedback.

Now, in the following paragraphs, multimedia transmission techniques will be deeply introduced, as well as different policies dedicated to evaluate the quality (and the distortion) of the perceived content.

### 3.1 Background and coding

The transmission of video over wireless media is becoming very popular for the different variety of applications and networks. The advantages of these transmissions over wireless media are evident, but the transmission rate will always be limited due to the limitations introduced by physical layer. So, having the possibility of compressing the video before transmission is crucial in such kind of environments, especially for real-time traffic, where some constraints are required. For these reasons, video decoder must tolerate delay and packet losses: the standards in video coding (like MPEG-4 and H.264/AVC) [16,17,18,19] are today very popular, because of their capability to adapt to these environments.

These standards, like the previous well known ones, use a hybrid coding approach. The Motion Compensated Prediction (MCP) is combined with transform coding of the residual components in order to obtain a codec that can be very useful nowadays. As described in previous paragraph, video communications can be categorized into unicast, multicast and broadcast services, with different peculiarities, depending on the desired service, like the on-line generated or pre-encoded content, video telephony and downloading.

Figure 4 illustrates a generic scheme of a video transmission system, including the main components that go from the transmitter device to the receiver device. Data compression is feasible also because video content presents significant redundancy (in time and in space) that reduces the amount of transmitted packets significantly. According to Figure 4, the video encoder generates data units containing the compressed video stream, which is stored in the encoder buffer before the transmission. In general, the transmission system damages

(quantitatively or qualitatively) individual data units, also introducing some delay; then, the encoder/decoder buffer are used in order to balance the bit-rate fluctuations produced by the encoder and by the wireless channel. In general, a coded video stream can be considered as composed by a sequence of data units, called Access Units (AU) in MPEG-4 or Network Abstraction Layer Units (NALU) in H.264. The AUs/NALUs can be labeled as data unit specific information (as in MPEG, where they are labeled on the basis of relative importance for video reconstruction). On the other hand due to spatial and temporal prediction the independent compression of data units cannot be guaranteed without significantly losing compression efficiency.

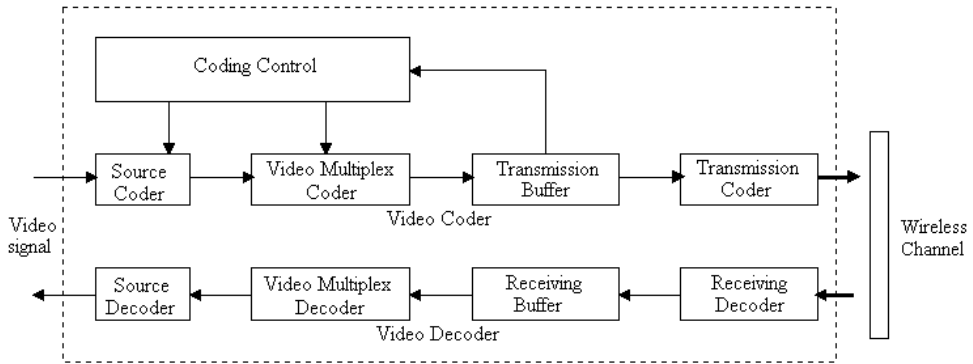

Fig. 4. Blocks diagram of a generic audio/video transmission system.

Errors introduction and its effects are considerably different in wired or in wireless networks, because of the different phenomena that impact on the medium. For wireless networks, fading and interference cause burst errors in form of multiple lost packets. Moreover congestion can result in lost packets in a wired IP network. Nowadays, even for wireless networks, systems are able to detect the presence of errors in a packet on physical layer and the losses are reported to higher layers. These techniques usually use Cyclic Redundancy Check (CRC) mechanisms. By consequence the video decoder will not receive the entire bit-stream. Intermediate protocol layers such as User Datagram Protocol (UDP) might decide to completely drop erroneous packets so deleting all the encapsulated data units. In fact, video data packets are considered lost if their delay overcomes a fixed and tolerable threshold, defined by the user video application.

Figure 5 illustrates a typical simplified version of an end to end video system when the MCP compressed video is transmitted over non error-free channels. In this environment,  $t$  represents the time,  $S_t$  is a single video frame composing a network packet  $P_t$ ,  $C_t$  (with values 1 or 0) indicates if  $P_t$  is correctly received or discarded, while  $S_t(C)$  represents the decoded frame as a function of the channel error pattern. Let assume that a packet is transmitted over a channel that forwards correct packets to the decoder, in case of successful transmission, the packet is forwarded to the normal decoder operation such as Entropy Decoding and Motion compensated Prediction.

The prediction information and transform coefficients are reloaded from the coded bit-stream to reconstruct the current frame  $S_{t-1}$ . After that, the frame is forwarded to the display buffer and also to the reference frame buffer to be used in the MCP process to reconstruct



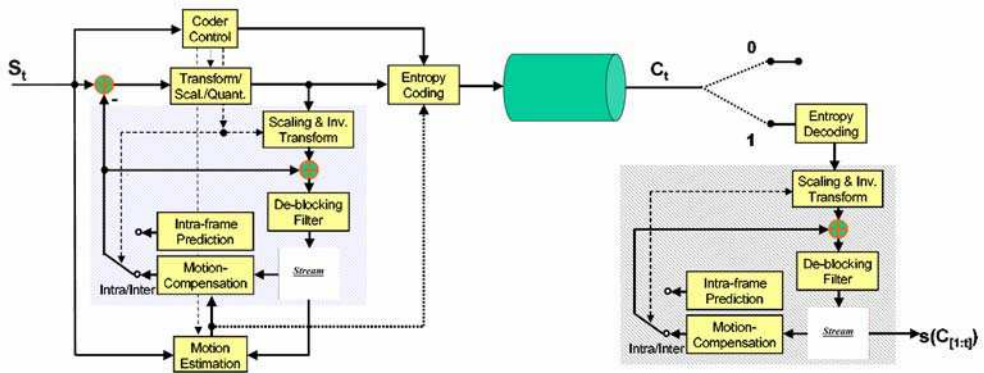

Fig. 5. End to end video transmission system.

the following inter-coded frames (i.e. the frame  $s_t$  frame). When the packet  $P_t$  is lost, i.e. at the reference time  $t$ ,  $C_t = 0$ , the Error Concealment (EC) is necessary to be enabled, so the decoder just avoids the decoding operation and the display buffer is not updated, so the displayed frame is still  $S_{t-1}$ . In this case the viewer will understand that there has been a loss of motion, since the continuous display update is not maintained. Also the reference frame buffer is not updated as a result of this data loss.

In case of successful reception of packet  $P_{t+1}$ , the inter-coded frame  $S_{t+1}$ , reconstructed at the decoder, will in general not be identical to the reconstructed frame  $S_{t+1}$  at the encoder side, because as the encoder and the decoder refer to a different reference signal in the MCP process, there will be a reconstruction mismatch in reference signal when decoding  $S_{t+2}$ . For this reason it is obvious that the loss of a single packet  $P_t$  affects the quality of all the inter-coded frames:  $S_{t+1}$ ,  $S_{t+2}$ ,  $S_{t+3}$ , etc. This phenomenon is present in any predictive coding scheme and is called error propagation. If predictive coding is applied in the spatial and temporal domains of a sequence of frames, it is referred to as spatio-temporal error propagation.

The MCP technique makes the reconstructed frame  $S_t$  not only depending on the actual channel behavior  $C_t$ , but also on the previous channel evolution  $C[1..t]$ .

After these considerations, remarking that the error propagation has direct consequences on the perceived video content, it is preferable that a video coding system provides some of the following features:

- a reliable communication mean, in order to avoid transmission errors;
- an algorithm or device dedicated to the reduction of the visual effects of errors in the received frames;
- an algorithm or device for the minimization of the error propagation effect.

Generally, in MCP coding, the video content that belongs to a single frame is not encoded as a single entity: it is composed by a macro-block and individual data units are syntactically accessible and independent. The features that are employed in these systems to correct the introduced errors are the Forward Error Correction (FEC) and Backward Error Correction (BEC) or any combinations of those. It is very important, at the receiver size, that the erroneous and missing video content is observed, localized and, if possible, eliminated or minimized.

The modern video coding systems also have the capability to inform the video encoder about the loss of the video content, so the encoder can adapt itself to enhance the

transmission quality. The macro-blocks assignments, error control methods and feedbacks transmission, for example, must be used if we desire a robust, efficient and 'error-free' application.

As known in literature, if Shannon's separation principle [20] is observed, the main goal in video transmission (that is low error or error-free propagation) can be reached: the compression (or coding) features and the transmission (or link layer) ones can be optimized separately in order to avoid losses in video transmissions.

However, in several applications and environments (low delay situations), error-free transport may be impossible and the features like channel loss correction, detection and localization of unavoidable errors, their minimization, reduction of distorted frames impact become essentials. When we are dealing with 'no-wired' systems and QoS guarantees must be given, error control such as FEC and retransmission protocols are the primary features that should be provided.

The rules that are provided by the video coding standards, such as H.263 [21], MPEG-4 [22] and H.264, beyond the syntax and the semantics of the transmitted data, specify the decoder behavior in case of reception of an error-free bitstream, so the deployment of video coding standards still provides a significant amount of freedom for decoders that have to process erroneous bitstreams. In this way, a processing algorithm may be better than another one, in terms of computational complexity or quality of the received content. In the last years, video compression tools have evolved significantly over time: previous standards, like H.261, MPEG, MPEG-2 [23, 24], are very limited in error resilience capabilities, while the latter ones (starting from the H.263 [25]), heavily influenced the applications, with a lot of improvements and tools for error resilience. In the meantime, the new emerging standard MPEG-4 Advanced Simple Profile (ASP) introduced a radically different approach, based on some resilience tools, like Reversible Variable Length Coding (RVLC) and Resynchronization Markers (RM) were introduced [26]. Figure 6 shows the evolution in time of the video compression standards.

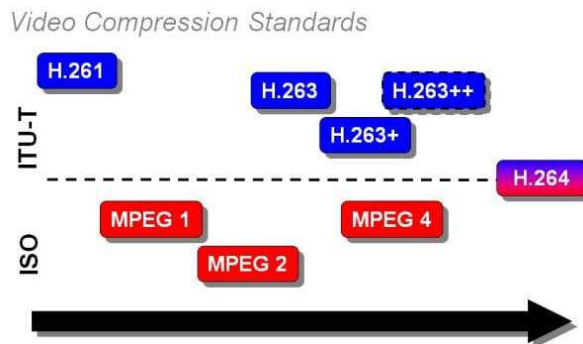

Fig. 6. The evolution of video compression standards.

As exposed in previous paragraphs, it is evident that the main aim of a communication system is to transfer the data generated by an information source efficiently and reliably over a non-ideal channel, respecting some QoS constraints. Among the different employed components (encoder, modulator, demodulator, source decoder) a channel encoder is used to insert additional and redundant data to the information sequence, so that channel errors can be detected or corrected. Shannon's channel coding theorem affirms that if there is

channel capacity (that is to say it is larger than the data rate), a coding scheme can be useful to reduce error probabilities. In general, the Bose-Chadhuri-Hocquenghem (BCH) codes are used and they represent an Error Control scheme based on block coding. They are a generalization of the Hamming codes and they add redundancy bits to the payload, in order to form code words; they also introduce the capacity of error correction (limited in number) [27]. The non-binary BCH-family codes that are massively used are the Reed Solomon (RS) codes. RS codes groups the bits into symbols, achieving good burst error suppression capability.

In order to achieve low-error (or error-free) communication, channel coding schemes must be implemented for the worst case channel characteristics. Obviously, when the channel is currently good, the channel protection, dimensioned for the worst case conditions, results in inefficient utilization of the wireless link. In addition, complex hardware or software structures may be required to realize the powerful long codes, required to defeat the worst case error patterns.

These drawbacks can be overcome by using the *Adaptive Coding* (AC) [28,29], by adding the redundancy on the basis of channel conditions and characteristics. Different adaptive algorithms have been proposed for video streaming applications, as the one proposed in [28]: in that work the fading level is estimated and, then, the algorithm evaluates the proper coding ratio in order to actively protect packets from losses. In this way, channel utilization can be immediately and efficiently improved.

### 3.2 Error perception

As discussed earlier, packet losses affect the quality of multimedia communications over wireless packet networks and the amount of quality degradation strongly vary on the basis of the meaning of the lost data. For the designing of an efficient loss protection mechanism, a reliable estimation method for multimedia data is needed. Providing an accurate estimation algorithm is required and in [30] the importance of a video coding element is outlined: for example, it is very useful to introduce the macro-block or packet concept as a value directly related to the distortion that would be introduced at the decoder by the loss of that specific element.

In Figure 7 the main phases of the “Analysis By Synthesis” (ABS) algorithm are illustrated; it is useful to compute the possible distortion of each element. It consists of the following steps, applied for each packet:

- decoding, with concealment, of the bitstream simulating the loss of the packet being analyzed (synthesis stage), by adding some errors;
- quality evaluation, in order to compute the distortion caused by the loss of the packet. The source and the reconstructed pictures are compared using Mean Square Error (MSE);
- storage of the obtained value as an indication of the perceptual importance of the analyzed video packet.

Little modifications of the standards are necessary in order to implement the modified encoding process. The algorithm reconstructs the encoded frames by the simulation of the decoder operations. It can be surely used for video coding, but the obtained values depend on the adopted encoding (if the video will be compressed with a different encoder or if a different packetization policy is used, values will be very different. The main disadvantage of the exposed technique consists of the interdependencies usually present between data

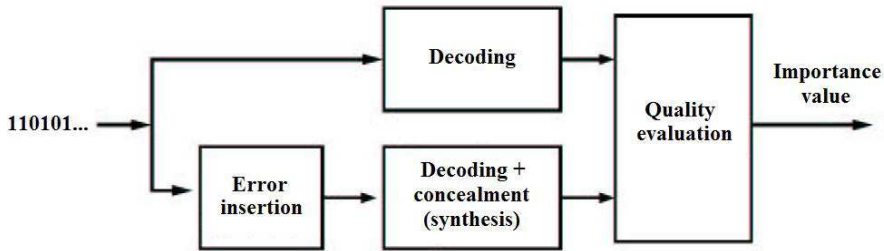

Fig. 7. Analysis by synthesis blocks diagram.

units, so the simulation of the loss of an isolated data unit is not completely realistic, particularly for high packet loss rates: all possible combinations of the events should be considered, weighted by its probability, and its distortion computed by the ABS technique, obtaining the expected importance value. The application of the ABS algorithm is easier when considering elements of the video stream which do not influence next frames (that is to say, no error propagation is present). If propagation is present, the distortion introduced in next frames should be evaluated until it is negligible (for example until a *I* frame is reached in a MPEG stream). In this case, the application of the ABS scheme is harder, due to the need of pre-computation of the perceptual distortion.

Another scheme for distortion evaluation is represented by the Distortion Matrix (DM) [31]: it allows to compute the distortion introduced when some frames are dropped in a sequence of Group Of Pictures (GOP) (as in an MPEG-2 stream). It is calculated under the assumption that once a specific *P* frame or *I* frame is lost, all the depending frames in the current GOP are replaced with the latest successfully decoded frame. This assumption makes the (DM) model unsuitable, because today all video decoders tend to mitigate the error propagation, reducing the distortion after a single loss. The GOP structure of video *k* is described by the GOP length  $L^k$  and the number of *B*-frames  $B^k$  between two *I* or *P* frames. For example, with  $L^k = 9$  and

$B^k = 2$ , the GOP structure will be *I B B P B B P B B*. The obtained distortion matrix as in [31] is shown in Figure 8.

$$\begin{matrix}
 R : \\
 I : \\
 P_1 : \\
 P_2 : \\
 B_1 : \\
 B_3 : \\
 B_5 :
 \end{matrix}
 \begin{bmatrix}
 D_I^R & D_{B_1}^R & D_{B_2}^R & D_{P_1}^R & D_{B_3}^R & D_{B_4}^R & D_{P_2}^R & D_{B_5}^R & D_{B_6}^R \\
 / & D_{B_1}^I & D_{B_2}^I & D_{P_1}^I & D_{B_3}^I & D_{B_4}^I & D_{P_2}^I & D_{B_5}^I & D_{B_6}^I \\
 / & / & / & / & D_{B_3}^{P_1} & D_{B_4}^{P_1} & D_{P_2}^{P_1} & D_{B_5}^{P_1} & D_{B_6}^{P_1} \\
 / & / & / & / & / & / & / & D_{B_5}^{P_2} & D_{B_6}^{P_2} \\
 / & / & D_{B_2}^{B_1} & / & / & / & / & / & / \\
 / & / & / & / & / & D_{B_4}^{B_3} & / & / & / \\
 / & / & / & / & / & / & / & / & D_{B_6}^{B_5}
 \end{bmatrix}$$

Fig. 8. DM for  $L^k = 9$  and  $B^k = 2$ .

The entries in the distortion matrix are the MSE values observed when replacing frame  $F_{loss}$  as part of the concealment strategy. The column left to the distortion matrix shows the

replacement frame for every row of the matrix.  $R$  is a frame from the previous GOP that is used as a replacement for all frames in the current GOP if the *I-frame* of the current GOP is lost. From this matrix, the resulting distortion for any possible loss pattern can be determined. The total distortion for the GOP is computed as the sum of the individual frame loss distortions. This matrix can be determined during the encoding of the video. The number of columns of the distortion matrix corresponds to the GOP length  $L^k$ . For more details see [31].

The ABS and DM end to end distortion estimation techniques can be categorized as “frame-based” methods, because they concern the distortion introduced at the frame level; other distortion evaluation techniques are well-known in the literature and they can be classified as “pixel-based” methods. In particular, the block-based approach generates and recursively updates a block-level distortion map for each frame [32,33,34]. Nevertheless, since inter-frame displacements influence sub-block motion vectors, a motion compensated block may inherit errors propagated from prior frames. In contrast, pixel-based policies estimate the distortion on a “pixel-basis”, so they have the advantage of providing high accuracy. Obviously, on the other hand, the complexity goes increasing. An innovative approach has been proposed in [35], where the distortion on pixel-basis is calculated by exhaustive simulation of the decoding procedure and averaging over many packet loss patterns. Another scheme is illustrated in [36], where only the two most likely loss events are considered.

However, in [37] it has been demonstrated that, by using the ROPE scheme, low complexity can be preserved, without losing the optimality of the distortion estimation algorithm. ROPE recursively calculates the first and second moments of the decoder reconstruction of each pixel, while accurately taking into account all relevant factors, including error propagation and concealment.

#### 4. MPEG Standards

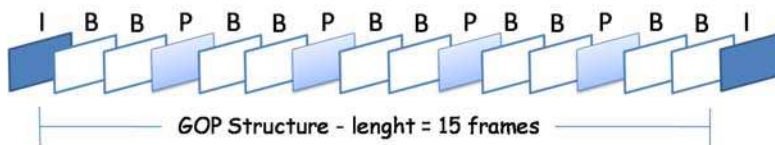

Fig. 9. GOP Structure

MPEG is the acronym of Moving Picture Experts Group, a working group which has the role of developing video and audio encoding standards [38].

MPEG video traffic is characterized by constant transmission rate of two groups of picture (GOP) (see Figure 9) per second and 15 frames per GOP. Since the number of bytes in a frame is dependent upon the content of the video, the actual bit rate is variable over time. However, the MPEG video supports also the constant bit rate (CBR) mode. There are three types of frames:

- I-Frames (intraframes) – encoded independently of all other frames;
- P-Frames (predictive frames) – encoded based on immediately previous I or P frames;
- B-Frames (bidirectionally predictive) – encoded based on previous and subsequent frames.

Many works in literature faced the problem of analyzing and describing the structure of MPEG-2 traffic streams, trying to find a way to emulate them through statistic and stochastic streams generators, preserving the proper and intrinsic nature of the original stream. In [39] the input process model is viewed as a compromise between the Long Range Dependent (LRD) and short range dependence (SRD) models. Simulation results were found to be better than those of a self-similar process when the switch buffer is relatively small. The MPEG video model presented in [40] is a Markov chain model based on the 'Group of Pictures' (GOP) level process rather than the frame level process. This has the advantage of eliminating the cyclical variation in the MPEG video pattern, but at the expense of decreasing the resolution of the time scale. Typically a GOP has duration of a half second, which is considered long for high speed networks. Of particular interests in video traffic modeling are the frame-size distribution and the traffic correlation. The frame size distribution has been studied in many existing works. Krunz [41] proposed a model for MPEG video, in which, a scene related component is introduced in the modeling of I frames, but ignoring scene effects in P and B frames. The scene length is i.i.d. with common geometric distribution. I frames are characterized by a modulated process in which the local variations are modulated by an Auto-Regressive (AR) process that varies around a scene related random process with log-normal distribution over different scenes; i.e., two random processes were needed to characterize I frames. The sizes of P and B frames were modulated by two i.i.d. random processes with log-normal marginal. This model uses several random process and need to detect scene changes, thus complicating the modeling process. In [42,43] the adaptive source is modeled by means of a discrete-time queuing system representing a virtual buffer, loaded by the video source when its quantizer scale parameter is changed according to the feedback law implemented in the encoder system. The whole paper is based on the Switched Batch Bernoulli Process (SBBP) that has been demonstrated to be suitable to model an MPEG video source; in fact, being a Markov modulated model, an SBBP is able to capture not only the first-order statistics but also the second-order ones which characterize the evolution of the movie scene.

In this paper we introduce a new concept of GOP-rate modeling, based on the discretisation method originally proposed in [44] for the wireless channel study. After the GOP-rate trend has been analyzed for the whole duration of the stream, it has been discretised in a certain number of states. Then the associated Markov Chain parameters have been evaluated.

MPEG algorithms compress data to form small bits that can be easily transmitted and then decompressed. It achieves its high compression rate by storing only the changes from one frame to another, instead of each entire frame. The video information is then encoded using a technique called Discrete Cosine Transform (DCT). MPEG uses a type of lossy compression, since some data is removed. But the diminishment of data is generally imperceptible to the human eye. The major MPEG standards include the following:

- MPEG-1: The most common implementations of the MPEG-1 standard provide a video resolution of 352-by-240 at 30 frames per second (fps). This produces video quality slightly below the quality of conventional VCR videos.
- MPEG-2: Offers resolutions of 720x480 and 1280x720 at 60 fps, with full CD-quality audio. This is sufficient for all the major TV standards, including NTSC, and even HDTV. MPEG-2 is used by DVD-ROMs. MPEG-2 can compress a 2 hour video into a few gigabytes. While decompressing an MPEG-2 data stream requires only modest computing power, encoding video in MPEG-2 format requires significantly more processing power.

- MPEG-3: Was designed for HDTV but was abandoned in place of using MPEG-2 for HDTV.
- MPEG-4: A graphics and video compression algorithm standard that is based on MPEG-1 and MPEG-2 and Apple QuickTime technology. Wavelet-based MPEG-4 files are smaller than JPEG or QuickTime files, so they are designed to transmit video and images over a narrower bandwidth and can mix video with text, graphics and 2-D and 3-D animation layers. MPEG-4 was standardized in October 1998 in the ISO/IEC document 14496.
- MPEG-7: Formally called the Multimedia Content Description Interface, MPEG-7 provides a tool set for completely describing multimedia content. MPEG-7 is designed to be generic and not targeted to a specific application.
- MPEG-21: Includes a Rights Expression Language (REL) and a Rights Data Dictionary. Unlike other MPEG standards that describe compression coding methods, MPEG-21 describes a standard that defines the description of content and also processes for accessing, searching, storing and protecting the copyrights of content.

## 5. Multimedia over satellite

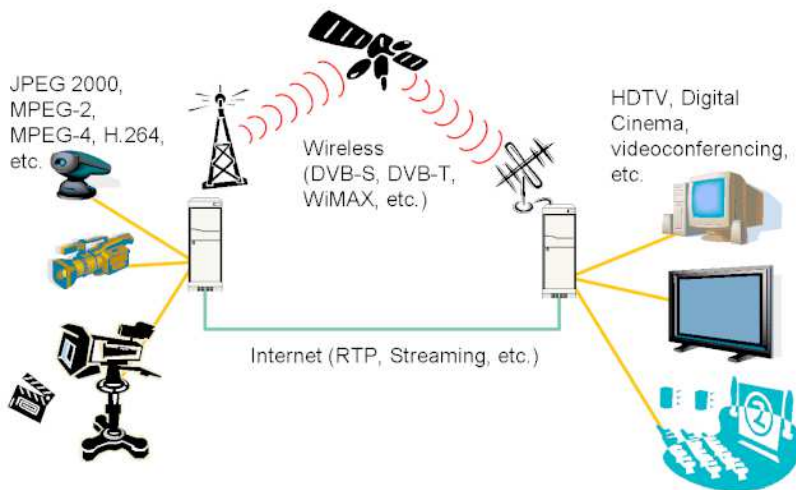

Fig. 10. Multimedia Broadcast Satellite Scenario

The new tendency of the multimedia applications on telecommunication networks is a full interactivity between users and network (see Figure 10). Thanks to this interactivity, users are able to manipulate what they receive on their terminal requiring to the network what they want. The interactivity has changed the way to exploit the network that pass from an asymmetry to a symmetry network. Then it is possible to use a return channel in order to make the users choices. This evolution in telecommunication also have consequences for satellite communications that, of sure, is the most oriented broadcast medium. Originally, the return channel of the satellite networks was designed as a terrestrial channel through different technologies such as PSTN, ISDN, GSM. Nowadays the most promising technology used for the satellite interactivity is a satellite one, in fact, the new standards for

satellite communications propose a return channel via satellite (RCS) like the DVB-RCS standard. The reasons for this choice are a lot, firstly customers prefer have a single technology for simplicity of management. It is very simple to have a single box in which all technical equipment are concentrates without have the necessity of interact with different objects. Another important reason regards the increased traffic in terrestrial networks that can produce problem in services providing such as service blocks and consequently reduction in quality of service. Moreover, the use of return satellite channel guarantees a greater bit rate available for the applications reaching a 2 Mbps against the few hundred of kbps of the terrestrial solutions. An example of this greater available bit rate can be seen on a file transfer application that for a 100 Mbyte file it will need about 7 minutes against the about 3 ½ hours of the terrestrial lines that operates a 64 kbps. There is also an advantage both for the users and the operators, that is to have both channels on the same medium. This produces a better control in QoS applications and in network management by operator, in fact, the terrestrial infrastructure is often not controlled by the same operator as for satellite, and this is certainly true when national borders are crossed.

Until 60 years ago, each individual communicated with about 100 other persons, of which 80-90 percent lived in closed vicinity. Twenty years ago this picture changed: each individual communicates with about 500 other individuals, of which 80-90 percent do not live in close vicinity. This was made possible by the emergence of advanced communications systems and by the integration of different technologies of communication that have allowed to reach users in very isolated areas. The emergence of new technologies has allowed the integration of different devices that originally worked separately as computers, TVs, telephones. Thanks to the Internet and to communication technologies always more sophisticates all consumers devices are able to work in a merged manner. The rapid technological advances will allow in a next future to have a exchange of information in every places and in every time.



Fig. 11. DVB Satellite Terminal

Satellite plays a key role in the telecommunications networks. It is able to resolve the problem of last mile providing connections to those areas where no investment return will be possible because a large investment is required to bridge services between the local exchange and the customers. Satellite, thanks to its broadband nature, is able to provide



connection in the rural areas and isolated areas with the same investment of other areas. Users has only to install a satellite terminal (see Figure 11) and subscribe to the service and they are able to receive satellite information. Moreover, thanks to the new RCS standard the customers can also use the network interactivity exploiting the return satellite channel that is faster than terrestrial one which is based on telephony network that are limited in providing high bit rates to subscribers. It will be necessary to perform a fiber cabling also between local exchange and subscribers in order to make faster the connections. Big investments are required by telephone companies to perform a fiber cabling in order to guarantee high bandwidth to each subscriber.

It is clear that the increase of multimedia services poses the problem of provide high bandwidth to the users by operators and in this context the use of satellite platform can represents an optimal solution in terms of costs. Moreover the satellite segment guarantees also an overall integration with all communication technologies.

### **5.1 Digital Video Broadcasting (DVB) system**

In the mid-eighties, the ability to transmit digital images was still remote and it was thought that it was neither technically nor economically feasible, at least in the short term. The main reason was the high bit rate required, especially for the transmission of digital images in motion (from 108 to 270 Mbps). The most important issue was to improve the quality of the TV, so huge amounts of capital were invested in research and development of IDTV (improved Definition Television) and HDTV (High Definition Television). The situation in the early nineties has completely changed: the creation of efficient compression algorithms has resulted in immediate result, the birth of the standard JPEG image for fixed and then the MPEG standard for moving images; thanks to MPEG compression the amount of data required for transmission of digital images up to decrease a bit rate of between 1.5 and 30 Mbps has been reduced drastically, depending on the resolution chosen and the type of content of the transmitted images. Soon we saw that digital television would have satisfied the requirements of suppliers of services, but only if they had adopted a common standard, which in 1993 gave rise to the DVB Project [45]. DVB, short for Digital Video Broadcasting, is used with reference to digital television services in accordance with the standards developed by a consortium of 300 organizations (both public and private) of more than 50 countries, operating in different sectors: from production to broadcast TV of television sets by the rules of the frequency spectrum to the study of protocols for access to a network. The members of this organization work with the DVB project to develop a set of standards, technical recommendations and guidelines available to the various manufacturers. Once given the specifications, these standards are published by ETSI (European Telecommunication Standards Institute), and then made accessible to all. So thanks to these open standards, manufacturers can create interoperable DVB systems and can also easily adapt to different transmission channels (satellite, terrestrial, cable, etc.). Although it was born for the European landscape, the DVB platform is beginning to be accepted as a world standard solution, a number of radio and television programs based on DVB standards are currently operating in North and South America, Africa, Asia and Australia.

DVB means is based on the standard ISO 13818 encoded MPEG-2 and multiplexing specifications. It defines how to transmit the signals using MPEG-2 satellite, cable and terrestrial repeaters, and as transmitting the information system, the program guide, etc.. DVB allows the broadcasting of "data containers" that can include digital data of any type, a

key element of DVB is the source encoding of MPEG-2 data to be transmitted in such containers. According to the channel through which must be sent the data stream it is possible to make a differentiation of DVB in:

- DVB-S (Satellite), for transmission via satellite;
- DVB-C (Cable), for transmission over coaxial cable;
- DVB-T (Terrestrial), for terrestrial wireless transmissions.

Some of the most important advantages of the DVB standard are:

- Integration of data with audio and video
- Multi-programming, i.e. the ability to transmit multiple programs on the same channel (multiplexing more than 8192 streams);
- variable transmission capacity to meet quality and quantity of programs;
- use of transmission capacity for the introduction of additional data services such as teletext and / or other multimedia services;
- high data rates (> 48Mbps);
- optimal exploitation of the bandwidth of channels on satellite radio that is terrestrial;
- High reliability of the service accessed through an efficient system of modulation and coding for error correction.
- Security of transmission

Existing DVB IP systems can be classified into two categories:

- Unidirectional DVB IP Systems called one way
- Bidirectional system called DVB RCS (Return Channel System).

While the uni-directional systems are aimed primarily at a consumer market, the bi-directional systems are directed to a business market. Both systems are based on the common standard, however, DVB. The DVB IP systems one way may use the terrestrial return channel via PSTN or ISDN lines (typically 64 Kbps). DVB RCS systems are on a satellite channel dedicated to increased capacity (up to 2 Mbps). DVB IP platforms are based on existing standard DVB-S (Digital Video Broadcasting) for a number of reasons. First, the DVB technology has become an industry standard, it is well tested and there are a large number of manufacturers producing DVB devices both transmitters and only receivers. This makes hardware prices very low compared to other via satellite systems. The standard DVB-S is indispensable for communication over long distances and enjoys all the advantages of the satellite medium:

- Large coverage
- Rapid activation link
- Broadcast and multicast can be ready
- Bypassing the congested networks
- Data rates asymmetric
- High scalability

The software fairly robust and well tested is capable of supporting the transmission system DVB services and streaming data delivery based on IP protocols. Finally, the IP over DVB is a system optimized for the distribution of high volumes of data via satellite. This system provides significant benefits for the relatively easy integration with DVB equipment used for receiving satellite TV and the widespread use of such equipment in the consumer.

The specification of the DVB IP data distribution is defined by the ETSI standard EN 301 192 for Data Broadcasting and illustrates a variety of ways for the dissemination of data. This standard is also based on standard ETSI / DVB DVB-S (ETS 300 421 - modulation and

channel coding for satellite) and DVB-SI (ETS 300 468 - Information Service). This specification identifies four modes of spread: the data piping, data transmission through streams (data stream), the encapsulation of several protocols (Multi Protocol Encapsulation MPE), and data carousels. MPE is the format standardized by ETSI, which ensures interoperability between different hardware that provide this function. The protocol supports MPE data broadcasting services that require the encapsulation of communication protocols, such as IP. This affects applications Unicast (each datagram is labeled to be directed to a single user) and Multicast (the datagram is directed to a group of users). In the MPE packets are "tagged" by the MAC address (Media Access Control), but the DVB standard does not deal with as it should be allocated and maintained that address. The technology that lies at the basis of DVB IP is the transport of data through the encapsulation of the IP datagram within the DVB. The following figure (Figure 12) shows the protocols stack provided for the DVB IP standard.

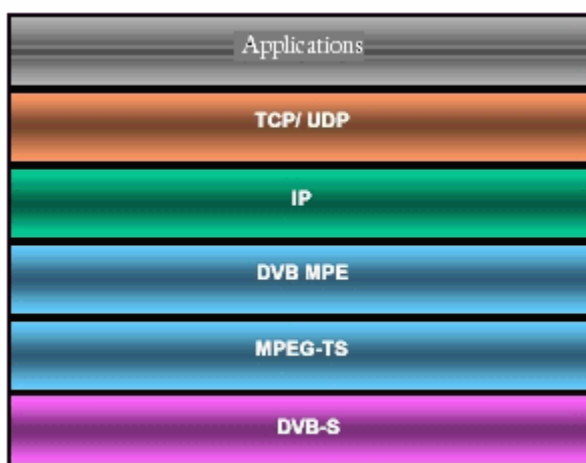

Fig. 12. Protocols stack of DVB IP standard

The MPEG-2 transport stream (MPEG-2-TS) arises from the need to create a layer of data for a fault tolerant environment (see Figure 13); and precisely, because this uses small packets. Although originally targeted for the spread of video and audio encoded in MPEG2 for digital television, the MPEG2-TS is particularly suitable for the transport of IP datagram. The transport stream consists of packets in time division multiplexed belonging to different flows of information. As already mentioned, each packet is 188 bytes, four of which belong to the header and the rest are left to the payload of the data. The header contains 4 bytes of synchronization and identification (PID) of the package, The payload (184 bytes) contains the data to be transmitted, such as data, audio and video format in small packages elementary (Packet Stream Element - PES). Each PES is of variable length and contains a header and a body of data called PES Data. The header of the PES includes a start code prefix, an identifier of flow, an optional length field, a PES-header and an optional number of bytes to fill. The remaining bytes are for data.

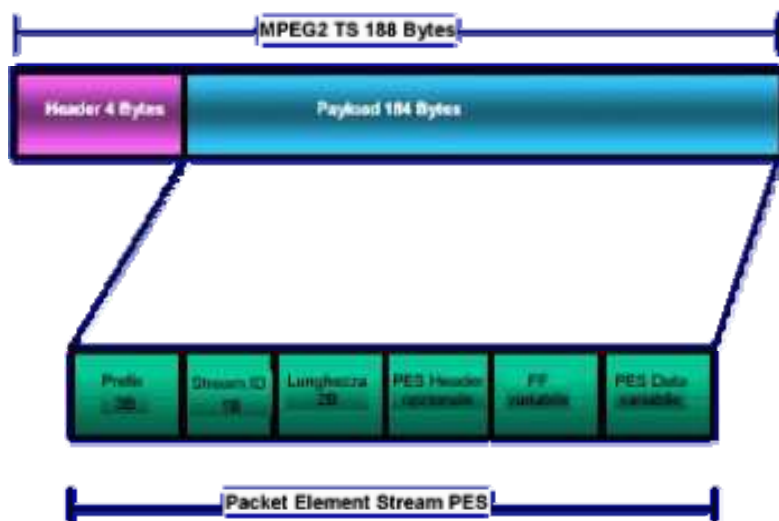

Fig. 13. MPEG 2 - Transport Stream

The large worldwide success of the DVB is due to the fact that it consists of a set of open standards, upon which they have agreed the entire DVB-Community made up of industrialists, traders, users, research institutes, etc. The DVB-RCS standard [46,47] was presented and approved ETSI (European Telecommunications Standards Institute) in 1999. Standard DVB-RCS is born as an evolution of TDMA networks where the carrier TDM (with bit rates up to 38Mbps), transmitted from the Master Station, transports the data packets in time division multiplexed addressed to all terminals of the network, instead, TDMA carriers (typically with bit rates up to 256Kbps) are shared between peripheral stations that have to talk with the Master Station. In order to make interoperable different technologies it has felt the need, at the European level, to define a standard which regulates the proliferation of networks with a star standard and proprietary hard interfaced with other technologies. The other reason that has necessitated the establishment of a standard DVB-IP was the proliferation of interactive applications with higher volumes of information that could not be implemented with the DVB-IP standard in which the return channel, made by a terrestrial link with a modem, did not allow an adequate bit rate (up to 64Kbps). The channel DVB-IP is referred to as direct channel or Forward Channel and the return channel RCS, Return Channel. The return channel has variable bit rate from 128Kbps up to 204Kbps and operates with TDMA in multi-access (MF-TDMA) in a dynamic way. The MF-TDMA access allows to give a slot of TDMA burst to terminals that request it in the pool of available frequencies. The channel DVB-IP or Forward Channel has a variable bit rate from 2Mbps up to 45Mbps and works with access TDM. The standard DVB-RCS can be implemented using a combination of Ku or Ka frequency for transmission and reception. The Ka-band offers to the Server Provider economic transponders to get a higher spectral efficiency. Such a system is designed to meet the needs of a wide section of users that can be distinguished into three categories:

- Prosumer
- Corporate
- Consumer

The main target is the Prosumer, a term used to describe a "professional user", which requires broadband, high-quality services and having the economic means to invest in relatively expensive equipment. The corporate customer is a further objective of the market, represented by a group of users who are behind a single terminal connected through a LAN for example, to a single RCST (Return Channel Satellite Terminal). The consumer will probably be the last profile that feels the need to use a similar system, but it is true the fact that the rapid technological development, together with the growing need for high capacity bandwidth and services, it will certainly make a category of users realistic in the near future. Let's look now at the applications on DVB-RCS:

- A first category of applications is made by "popular" services of the Internet, such as, for example, electronic mail, web-browsing, file transfer, and newsgroups.
- A second category of applications, so DVB-RCS exceed benefits in terms of access to the terrestrial network, is based on the multicast capability of the satellite such as multicast file transfer or streaming multicast. Many research results have led to a standard that supports the IP Multicast on the Internet. One of the major advantages of DVB-RCS standard is that it makes possible the Multicasting at low cost using existing Internet standards. The multicast data are channeled through an Internet Multicast Streaming Feeder Link, streaming from a source to a Multicast Streaming Server, then this data is transmitted on the satellite and sent to that particular group to which they were intended. The DVB-RCS system supports bandwidths relatively large for streaming compared to existing terrestrial solutions (from 64Kbps to 1Mbps).
- A third category of applications may be "Voice over IP." Broadband connections of DVB-RCS allows a good control of the flow constant rate. The biggest drawback is that the configuration of a star-RCS will require a double jump to a satellite connection between two users. This problem disappears if one user is connected to a hub through terrestrial links (PSTN or ISDN).

### 5.1.1 DVB Advantages and disadvantages

As already mentioned, the advantages of broadband satellite are undoubtedly significant: in addition to the ubiquitous availability of the service and the high speed of navigation available to users, in fact, are also to remember the cost lower than terrestrial connections, the possibility of subscribing services also with foreign companies, which means you have greater choice and range of commercial offers, and the opportunity to receive satellite TV channels on your personal computer at home or office. Another technical advantage is the equipment concentrated in a single box, called Set Top Box. Another reason for choosing a return channel via satellite is the significant increase in traffic of terrestrial networks that often reduces the quality of service (QoS). Finally, the forward channel and return channel is available on the same medium. This enables better control of QoS and network management by a single operator, which is not the case with terrestrial infrastructures that are not always handled by the same operator. QoS parameters include point-to-point delay, delay variation and packet loss. These parameters are measured on a path point-to-point, where the delay of propagation of the satellite was taken into account properly. In contrast, however, is also worth pointing out those that may be the defects of this type of connection as the inability to upload direct from most of the services, the excessive investment for purchasing the

necessary equipment for connection (satellite dish, LNB device, etc.), the problem of utilizing the phone line every time you make a web browsing (and the cost of calls made), the possibility of jamming signal that may occur due to the repositioning of satellites and weather situations, short delays in signal transmission due to the distance between the satellite and earth, and, not least, the difficulties of implementation and management of the connection that you can present to users are not particularly expert in the use of pc . The choice of the satellite connection is recommended, as well as to residents in areas not yet reached the service of terrestrial broadband, especially for users and companies that use the network to browse or download files of large size, but just recommended to all those realities, both professional and private, that are able to choose lines of traditional fast (even fiber optic) and require to send files on the network particularly heavy in terms of kb.

## 5.2 Platform integration: DVB-SH

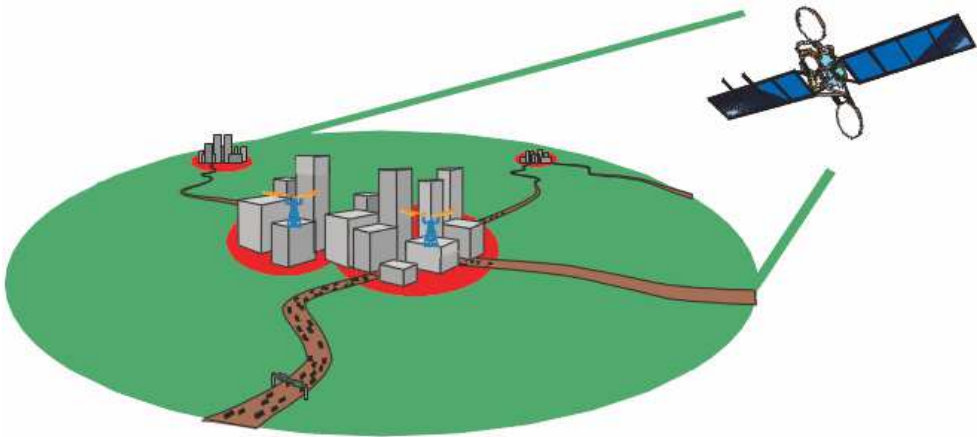

Fig. 14. DVB-SH Scenario

A new standard that is emerging in the DVB panorama is the DVB-SH whose first specification has been published in 2006 [48] (see Figure 14). It is a standard that includes the features of the well-known DVB-S and DVB-H. It is a hybrid system born to provide services through satellite and terrestrial platform to the users handheld, such as mobile phones, PDAs, vehicle-mounted, nomadic (laptops, palmtops...) and to fixed terminals. The hierarchical structure is composed of satellite platform and UMTS terrestrial repeater. This multi-layer structure allows to use the satellite communication when the conditions of LoS exist between satellite and device and, in the NLoS case, it can switch on the terrestrial repeaters in order to guarantee continuously connection to the subscribers. This standard has been designed to use frequencies around 3 GHz that fall in the S band (2.2 GHz) suitable for Mobile Satellite Service (MSS) and that are adjacent to the 3G terrestrial frequencies (see Figure 15).

DVB-SH inherits from the standard DVB-S many features such as turbo coding for forward error correction and a highly flexible interleaver in an advanced system designed to cope with the hybrid satellite/terrestrial network topology. The advantage of satellite channel is a

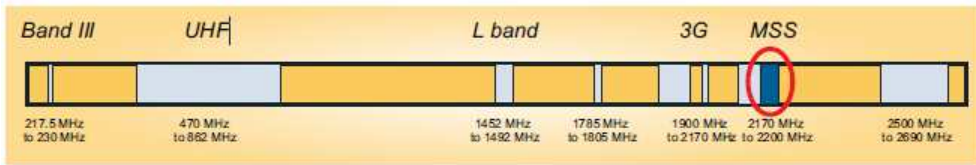

Fig. 15. 3G and S-Band spectrum

wide area coverage whilst the terrestrial component are able to provide coverage where the satellite signal cannot be received, as in urban canyon areas. The advantages of the terrestrial segment can be exploit for the deployment of repeaters for good indoor coverage otherwise not possible from satellite connection.

This new standard has to face with one of the most important application that in the last years is strongly emerging, the mobile TV; moreover it has to provide a lot of new multimedia services such as digital video streaming, voice over IP, Radio content delivery, interactive services, video on demand. The advantage of this system is the possibility of reach users that are in everywhere on the country and it guarantees access to users services that are moving in the region both walking or travelling in a car, train, ship. For this purpose the mobile terminal have to respect some required constrains in order to have the right compatibility with the mobility in term of size, weight and power consumption.

**5.3 Satellite Digital Multimedia Broadcasting (SDMB) system**

The Satellite Digital Media Broadcasting (S-DMB) system [49] consists in an overlay network based on satellite communications dedicated to terrestrial UMTS segments as it is possible to see in Figure 16. It is used when multimedia content, like TV programs, or non real-time multimedia services should be delivered to mobile nodes. This can be done by the use of geostationary satellites and low power terrestrial stations, which act like gap-fillers in order

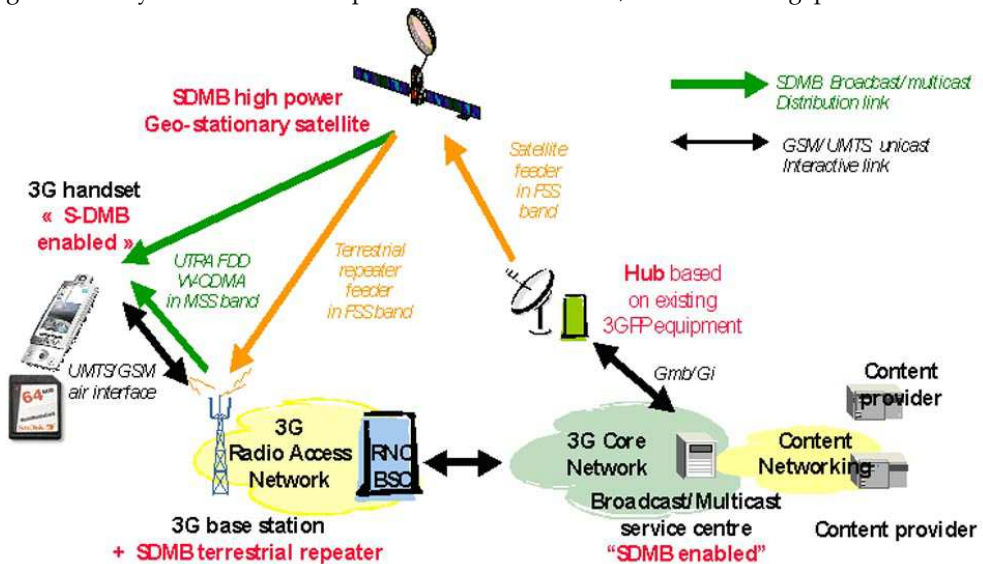

Fig. 16. SDMB Scenario

to cover urban and indoor environments. They can be located in the same places of mobile base stations. Satellites and terrestrial repeaters communicate with synchronized signals and the end-user nodes can use such kind of signals to improve reception quality. The S-DMB system is based on 18 channels (at 128kbps) in 15MHz, fully compliant with the UMTS Multimedia Broadcast/Multicast Service (MBMS). In this way, the integration among S-DMB/UMTS can become very useful. The streaming of TV programs on the own handset is suitable for end-users: it can be done wherever they are (waiting for a bus, for a TAXI, relaxing in a park, etc.); the only needed thing is a 3G compatible phone, although new technologies are taking place, like DVB-H or T-DMB.

The DMB is the natural extension of the Digital Audio Broadcasting (DAB) and there are two different versions of it: terrestrial or satellite DMB. Figure 17 represents the countries where the broadcasting technologies are employed (Europe, Canada, Australia, South Africa, New Zealand, India, China, South Korea and Turkey).

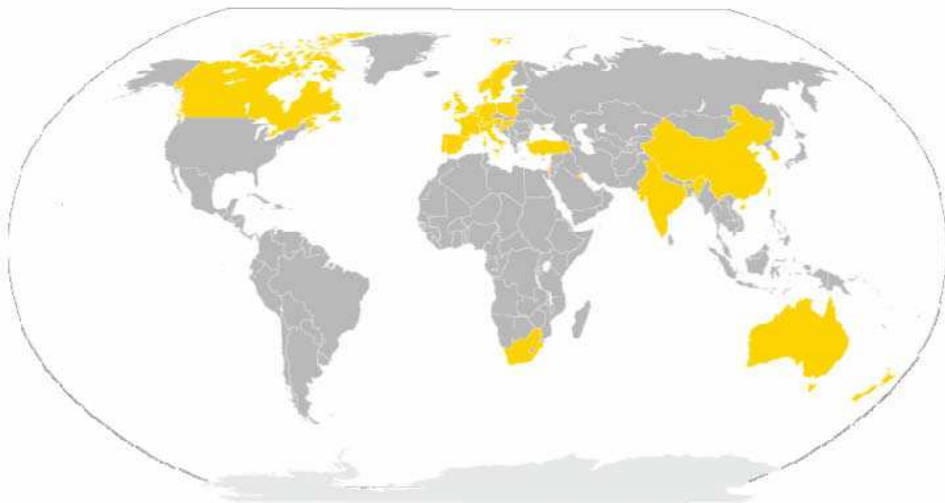

Fig. 17. DAB/DMB use in the world

#### 5.4 Radio Resource Management in satellite environment

The Radio Resource Management (RRM) functionalities implemented at the Satellite broadcasting access layer comprise two main separated but cooperated parts: packet scheduling and connection admission control (CAC).

The physical channels are multiplexed in the satellite gateway through a radio resource allocation procedure. That is responsible of the radio bearer configuration at the time of the admission for each session, which includes the estimation of the required number of logical, transport and physical channels and their mapping from logical channels to the transport, physical channels.

The main function of a scheduling algorithm is to perform a time-multiplexing together with a QoS differentiated service flows and adjust the transmit power setting for each physical channel according.

The admittance decision of each incoming requested session is handled by the admission control function.



### 5.4.1 Packet scheduling schemes

The scheduling algorithm is responsible for managing the situations of contention for shared resources and limited, such as a buffer, a CPU, etc., In order to guarantee certain QoS requirements and fairness. In the telecommunications sector is often used algorithms to solve scheduling problems of access to the medium and, for example, to determine which users can transmit data over a communication channel shared. In this application, the main constraints to which the scheduling policies must be followed, among others, compliance with constraints on the delay, end-to-end, the jitter, the level of drop packages, or implementing a policy of "fair share" of resources among various users. The design of a scheduling algorithm is through the definition of objectives and constraints that the algorithm must satisfy. It is often necessary to adopt a scheduling algorithm in application scenarios characterized by response times are very low, so it is necessary that the algorithm can make decisions in a much reduced and with the least possible computational load. For example, in a network to 1Gbps with 1Kbyte packets, we will send a packet on average every 8  $\mu$ sec, the scheduling algorithm must be extremely fast in taking its decisions. Moreover, it is necessary to restrict the use of sophisticated data structures to implement the algorithm, as this would limit its use in real systems, with computing resources and memory are often limited. Many scheduling policies have a requirement to provide a breakdown "right" of resources, namely the maintenance require a certain level of "fairness" among users. An allocation of resource is "fair" if it meets the criterion of max-min allocation. " In an informal test this is to first meet the demand of small users, dividing among all the possible resource remaining. A policy of fair share, of course, cannot be applied to connections with guaranteed service, where users pay to receive a certain level of service [50].

Let us suppose to have a resource with capacity  $C$  and  $n$  service users with applications for resource  $x_1, \dots, x_n$ . Formally, the steps to follow to obtain a "fair share" of the resource according to the criterion of max-min allocation is as follows:

1. Let order the resource requests for increasing capacity, so that  $x_1 \leq x_2 \leq \dots \leq x_n$ .
2. It chooses the smallest request not yet satisfied, it assigns, initially, the amount  $C/n$  of the resource.
3. If  $C/n > x_1$  it distributes the surplus in an equitable manner among all the other  $n-1$  requests.
4. The algorithm takes from point 1 until all requests were taken into account.

Other algorithm features may include the presence of priority levels, the respect or not of the law of work conservation, rules for the connections aggregation on the basis of priority level, etc. ...

A scheduler is called "work-conserving" when the server is free only when the queue is empty.

### 5.4.2 Call admission control algorithms

Efficient radio resource management and CAC strategies are key components in wireless system supporting multiple types of applications with different QoS requirements. CAC tries to provide QoS to multiple types of applications with different requirements considering both call level and packet level performance measures. A CAC scheme aims at maintaining the delivered QoS to different calls (or users) at the target level by limiting the number of ongoing calls in the system. Call admission control (CAC) schemes have been investigated extensively in each type of network. Different approaches of CAC exist in literature, centralized, distributed, Traffic-Descriptor-Based, Measurement-Based and so on [51,52].

In satellite networks, different types of admission control have been studied. In [53] the authors have presented a novel strategy for handling ATM connections of different natures, traffic profile, and QoS requirements in enhanced satellite systems. CAC represents a module of Network Operation Center (NOC) disposed on a terrestrial station. Its task is to regulate the access to satellite segment. It permits a flexible handling of the bandwidth and avoids the a priori partitioning of the resources among different types of service. The CAC algorithm has been designed also to fulfill the objectives of minimizing the signaling exchange between the on-board and on-earth segments of the system. In order to reduce delays due to the processing of the call requests on board, the relevant parameters of the processed calls are stored and elaborated within the ground segment. The method is based on the concept of reserving buffer resources to each virtual circuit as long as data are sent. The decision on the call acceptance is taken following the evaluation of the excess demand probability, i.e., the probability that the accepted calls during their activation periods request more buffer resources than those available.

In [54,55] the authors propose an adaptive admission control strategy, which is aimed at facing link congestion and compromised channel conditions inherent in multimedia satellite networks. They present the performance comparisons of a traditional (fixed) admission control strategy versus the new adaptive admission control strategy for a Direct Broadcast Satellite (DBS) network with Return Channel System (DBS-RCS). Fixed admission control uses the same algorithm independent of the past traffic characteristics. The Bandwidth Expansion Factor (BEF) for VBR traffic is determined such that the probability of the aggregate instantaneous rate exceeding the fraction of the capacity assigned to the admitted VBR services will not be greater than a pre-specified probability value ( $\epsilon$ ). The dynamic approach recognizes that the admission control can only approximately estimate the statistical multiplexing and attempts to use the characteristics of past traffic streams to better estimate the gain that can be achieved. Unlike the fixed admission control, the adaptive admission control adjusts the BEF such that the actual value of is close to the desired value  $\epsilon$  that is restricted by the acceptable QoS limits.

Concerning the Video Broadcasting delivery and scalability properties to be offered for large scale and heterogeneous networks, the authors in [56] adopted a Video on Demand (VoD) scheme where VBR videos are mapped over CBR channels and a traffic smoothing scheme with a buffering delay control are proposed. The same authors in [57], proposed novel broadcasting and proxy caching techniques in order to offer more scalability to the video delivery and to increase the overall performance of the system. In [58], the authors proposed a scheme to reduce the waiting time of the video application client side. The video traffic considered by authors was MPEG2.

In [59] the author performs a comparison between Quality oriented adaptation scheme (QOAS) against other adaptive schemes such a TCP Friendly Rate Control Protocol (TFRC), Loss-Delay-based Adaptation Algorithm (LDA+) and a non adaptive (NoAd) solution when streaming multiple multimedia clips with various characteristics over broadband networks.

The purpose of this study in [60] is to propose a quality metric of video encoded with variable frame rate and quantization parameters suitable for mobile video broadcasting applications. In [61] the authors present the results of a study that examine the user's perception of multimedia quality when impacted by varying network-level parameters (delay and jitter).

In contribution [62] they considered the GOP loss ratio as QoS parameter to be respected and VBR traffic has been considered in a DVB-RCS architecture.

## 6. Conclusions

In this chapter an analysis of the multimedia traffic over Wireless and Satellite networks has been shown. The importance of managing multimedia applications nowadays in the overall networks is an incontrovertible fact of our life. Moreover, the rapid increased use of mobile terminal together with video and audio services have pushed the research and the researchers toward new standards and technologies capable of dealing with these new users requirements. An important aspect of multimedia delivery contest is the possibility of make integration between different networks in order to be able of reaching users every-time every-where. Personal video recorders, video on demand, multiplication of program offerings, interactivity, mobile telephony, and media streaming have enabled viewers to personalize the content they want to watch and express their preferences to broadcasters. Viewers can now watch television at home or in a vehicle during transit using various kinds of handheld terminals, including mobile phones, laptops computers, and in-car devices. The concept of providing television-like services on a handheld device has generated much enthusiasm. Mobile telecom operators are already providing video-streaming services using their third-generation cellular networks. Simultaneous delivery of large amounts of consumer multimedia content to vast numbers of wireless devices is technically feasible over today's existing networks, such as third-generation (3G) networks. The concept of mobility has push toward wireless solutions such as terrestrial wireless networks and satellite one. Moreover, in the recent years new standards have been proposed for a integration of this two types of platforms giving the birth of hybrid solution like DVB-SH and SDMB standard. These standards provide integration between satellite and 3G networks in order to guarantee services also to those areas where the terrestrial infrastructures are impossible to install both for the particular territorial morphology and for economical issues.

## 7. References

- [1] Erling Kristiansen, Roberto Donadio, "Multimedia over Satellite - the European Space Agency Perspective", 2004
- [2] Wang Jian-ming, Zhan Shi Xian, and Zhao Xu Dong, "Improving the Multimedia traffic Performance over Wireless LAN", IEEE 2005
- [3] Vincent Chavoutier, Daniela Maniezzo, Claudio E. Palazzi, Mario Gerla, "Multimedia over Wireless Mesh Networks: Results from a Real Testbed Evaluation", Med Hoc Net 2007.
- [4] M-Etoh, T.Yoshimura, "Advances in Wireless Video Delivery," Prof.of the IEEE, vol.93, no.1, Jan.2005, pp.111-122.
- [5] Quan Huynh-Thu, Mohammed Ghanbari, "Temporal Aspect of Perceived Quality in Mobile Video Broadcasting" IEEE Transaction on Broadcasting, vol. 54, no. 3, September 2008.
- [6] Gabriel-Miro Muntean, Gheorghita Ghinea, Pascal Frossard, Minoru Etoh, Filippo Speranza, Hong Ren Wu, "Advanced Solution for Quality-Oriented Multimedia Broadcasting", IEEE Transaction on Broadcasting, vol. 54, no. 3, September 2008.
- [7] Stefan Winkler, Praaven Mohandas, "The Evolution of Video Quality Measurement: From PSNR to Hybrid Metrics", IEEE Transaction on Broadcasting, vol. 54, no. 3, September 2008.

- [8] Noriki Uchida, Kazuo Takahata and Yoshitaka Shibata, "Optimal Video Stream Transmission Control over Wireless Network", IEEE International Conference on Multimedia and Expo (ICME) 2004
- [9] Ron Shmueli, Ofer Hadar, Revital Huber, Masha Maltz, and Merav Huber, "Effects of an Encoding Scheme on Perceived Video Quality Transmitted Over Lossy Internet Protocol Networks", IEEE Transaction on Broadcasting, vol. 54, no. 3, September 2008.
- [10] ITU-R Recommendation BT.500-11, "Methodology for the subjective assessment of the quality of television pictures," International Telecommunication Union, Geneva, Switzerland, 2002.
- [11] ITU-T Recommendation P.910, "Subjective Video Quality Assessment Methods for Multimedia Applications," International Telecommunication Union, Geneva, Switzerland, 1999.
- [12] ITU-T Recommendation P.911, Subjective Audiovisual Quality Assessment Methods for Multimedia Applications International Telecommunication Union, Geneva, Switzerland, 1998.
- [13] P. Corriveau, "Video quality testing," in Digital Video Image Quality and Perceptual Coding, H. R. Wu and K. R. Rao, Eds. Boca Raton, FL: CRC Press, 2006, ch. 4
- [14] ITU-T P911: "Subjective audiovisual quality assessment methods for multimedia applications".
- [15] S. Winkler, "Video quality and beyond", in Proc. European Signal Processing Conference, Poznan, Poland, Sept. 3-7 2007, invited paper.
- [16] Advanced Video Coding for Generic Audiovisual Services," ITU-T and ISO/IEC JTC 1., 2003.
- [17] G. Sullivan and T. Wiegand, "Video compression from concepts to the H.264/AVC standard," in *Proceeding of the IEEE*, vol. 93, June 2005.
- [18] A. M. Tourapis, K. Sühring, G. Sullivan, *Revision of the H.264/MPEG-4 AVC Reference Software Manual*, Dolby Laboratories Inc., Fraunhofer-Institute HHI, Microsoft Corporation, JVT-W041, April 2007.
- [19] A. Luthra, G. Sullivan, T. Wiegand, *Special Issue on the H.264/AVC video coding standard*. IEEE Transaction on Circuits and Systems for Video Technology, July 2003, vol. 13, no. 7.
- [20] C. E. Shannon, "A Mathematical Theory of Communications," *Bell Systems Technology*, p. 379-423, 1948.
- [21] "Video coding for narrow telecommunication channels at 64 kbit/s," ITU-T Recommendation H.263, 1996.
- [22] S. Bauer, J. Kneip, T. Mlasko, B. Schmale, J. Vollmer, A. Hutter, and M. Berekovic, "The mpeg-4 multimedia coding standard: Algorithms, architectures and applications," *J. VLSI Signal Process. Syst.*, vol. 23, no. 1, 1999.
- [23] "Video Codec for audiovisual services at p x 64 kbits/s," ITU-T Recommendation H.261, 1990.
- [24] D. Banks and L. A. Rowe, "Analysis tools for mpeg-1 video streams," EECS Department, University of California, Berkeley, Tech. Rep. UCB/CSD-97-936, Jun 1997. [Online]. Available: <http://www.eecs.berkeley.edu/Pubs/TechRpts/1997/5497.html>
- [25] Bernd Girod, "Comparison of the H.263 and H.261 Video Compression Standards."
- [26] T. Chujoh and T. Watanabe, "Reversible variable length codes and their error detecting capacity," in *Proceeding of the IEEE*. Portland, (OR): Picture Coding Symposium, 1999, pp. 341-344.

- [27] H. Liu, H.Ma, M. E. Zarki, and S. Gupta, "Error control schemes for networks: An overview," *Mobile Networks and Applications*, no. 2, p. 167-182, June 1997.
- [28] W. Kumwilaisak, J. Kim, and C. Kuo, "Reliable wireless video transmission via fading channel estimation and adaptation," in *Proceedings of IEEE WCNC, Chicago, IL*, September 2000, p. 185-190.
- [29] S. Lin and D. C. Jr., *Error Control Coding*, 2nd ed., ed., Ed. Prentice Hall, 2004.
- [30] E. Masala and J. C. De Martin, "Analysis-by-synthesis distortion computation for rate-distortion," in *IEEE International Conference on Multimedia and Expo*, Baltimore, MD, Ed., vol. 3, July 2003, p. 345-348.
- [31] W. Tu, W. Kellerer, and E. Steinbach, "Rate-Distortion Optimized Video Frame Dropping on Active Network Nodes," in *IEEE Proceedings of the International Packet video Workshop*, Irvine, CA, Ed., December 2004.
- [32] G. Cote, S. Shirani, and F. Kossentini, "Optimal mode selection and synchronization for robust video communications over error prone networks," *IEEE Journal on Selected Areas in Communications*, vol. 18, no. 6, pp. 952-965, June 2000.
- [33] S. Ekmekci and T. Sikora, "Recursive decoder distortion estimation based on source modeling for video," in *Proceeding of International Conference on Image Processing(ICIP)*, 2004, p. 187-190.
- [34] Y. Zhang, W. Gao, H. Sun, Q. Huang, and Y. Lu, "Error resilience video coding in H.264 encoder with potential distortion tracking," in *Proceeding of International Conference on Image Processing(ICIP)*, vol. 1, 2004, p. 173-176.
- [35] T. Stockhammer, T.Wiegand, and S.Wenger, "Optimized transmission of H.26L/JVT coded video over packet-lossy networks," in *Proceeding of International Conference on Image Processing(ICIP)*, Rochester, NY, vol. 2, 2002, p. 173-176.
- [36] T.Wiegand, N. Farber, K. Stuhlmuller, and B. Girod, "Error-resilient video transmission using long-term memory motion-compensated prediction," *IEEE Journal on Selected Areas in Communications*, vol. 18, no. 6, pp. 1050-1062, June 2000.
- [37] R. Zhang, S.L. Regunthan, and K. Rose, "Video coding with optimal inter/intra-mode switching for packet loss resilience," *IEEE Journal on Selected Areas in Communications*, vol. 18, no. 6, pp. 966-976, June 2000.
- [38] B.Haskell, A.Puri, and A.Netravali, *Digital MPEG: An Introduction to MPEG-2*, London, U.K.: Chapman and Hall, 1997.
- [39] M. M. Krunz and A. M. Makowski, "Modeling video traffic using M/G/1 input processes: a compromise between Markovian and LRD models", *IEEE J. Select. Areas Commun.*, vol. 16, no. 5, pp. 733-749, Jun. 1998.
- [40] O. Rose, "Simple and efficient models for variable bit rate MPEG video traffic", *Performance Evaluation*, vol. 30, pp. 69-85, 1997.
- [41] M. Krunz and S. K. Tripathi, "On the characterization of VBR MPEG streams", in *Proc. SIGMETRICS'97*, Cambridge, MA, Jun. 1997, pp. 192-202.
- [42] A.Lombardo,G. Morabito,G. Schembra, "Modeling intramedia and intermedia relationships in multimedia network analysis through multiple timescale statistics," *IEEE Transactions on Multimedia*, Vol.6, no.1, Feb. 2004, pp.142-157.
- [43] A.Lombardo, G.Schembra, "Performance evaluation of an adaptive-rate MPEG encoder matching IntServ traffic constraints," *IEEE/ACM Trans.on Networking*, Vol.11, no.1, Feb. 2003, pp.47-65
- [44] X. S. Wang, Moayeri, "Finite-state Markov channel - a useful model for radio communication channels", *IEEE Transactions on Vehicular Technology*, Volume 44, Issue 1, Feb. 1995 Page(s):163 - 171.
- [45] [www.dvb.org](http://www.dvb.org)

- [46] ETSI TR 101-790 V1.1.1 Digital Video Broadcasting (DVB); Interaction Channel for Satellite Distribution Systems; Guidelines for the use of EN 301-790.
- [47] ETSI, "Digital Video Broadcasting (DVB); Interaction channel for Satellite Distribution System," DVB-RCS 333, REV6.0, 22Feb. 2002.
- [48] Philip Kelley, Christian Rigal, "DVB-SH - mobile digital TV in S-Band", EBU TECHNICAL REVIEW - July 2007.
- [49] Christophe Selier, Nicolas Chuberre, "Satellite Digital Multimedia Broadcasting (SDMB) system presentation", 14-th IST Mobile and Wireless Communication Summit, Dresden, 19-23 June 2005.
- [50] Linghang Fan, Hongfei Du, Upendra Mudugamuwa, Barry G. Evans, "A Cross-Layer Delay Differentiation Packet Scheduling Scheme for Multimedia Content Delivery in 3G Satellite Multimedia System", IEEE Transaction on Broadcasting, vol. 54, no. 4, December 2008.
- [51] L.Huang, C.-C.Jay Kuo, "Joint Connection-Level and Packet Level Quality-of-Service Support for VBR Traffic in Wireless Multimedia Networks," IEEE Journ.on Selected Area in Comm.,vol. 23, no.6, June 2005, pp.1167-1177.
- [52] D.Niyato, E. Hossain, "Call Admission Control for QoS Provisioning in 4G Wireless Networks: Issues and Approaches", IEEE Network, Sept./Oct. 2005
- [53] A.Iera, A.Molinaro, S.Marano, "Call Admission Control and resource management issues for real-time VBR traffic in ATM-satellite," IEEE Journ.on Selected Area in Comm., vol.18, pp.2393-2403, Nov.2000.
- [54] F.Alagoz, et al., "Fixed versus Adaptive Admission Control in Direct Broadcast Satellite Networks with Return Channel Systems," IEEE Joun.on Selected Areas in Comm., Vol.22, No.2, Feb.2004, pp.238-249.
- [55] F.Alagoz, "Approximation on the aggregate MPEG traffic and their impact on admission control," Turkish J.Elec.Eng.Comput.Sci., vol.10, pp.73-84, 2002.
- [56] W.-F.Poon, K.-T.Lo, J.Feng, "Interactive Broadcasting System for VBR Encoded Videos," in IEEE Transaction on Broadcasting, Vol.53, No.2, June.2007, pp.459-467.
- [57] K.-M.Ho, W.-F.Poon, K.-T.Lo, "Performance Study of Large-Scale Video Streaming Services in Highly Heterogeneous Environment," in IEEE Transaction on Broadcasting, Vol.53, No.4, Dec.2007, pp.763-773.
- [58] T.Yoshihisa, M.Tsukamoto, S.Nishio, "A Broadcasting Scheme Considering Units to Play Continuous Media Data," in IEEE Transaction on Broadcasting, Vol.53, No.3, Sept.2007, pp.628-636.
- [59] G.-M.Muntean, "Efficient Delivery of Multimedia Streams Over Broadband Networks Using QOAS," in IEEE Transaction on Broadcasting, Vol.52, No.2, June.2006, pp.230-235.
- [60] R.Feghali, et al., "Video Quality Metric for Bit Rate Control via Joint Adjustment of Quantization and Frame Rate," in IEEE Transaction on Broadcasting, Vol.53, No.1, March.2007, pp.441-446.
- [61] S.R.Gulliver, G.Ghinea, "The Perceptual and Attentive Impact of Delay and Jitter in Multimedia Delivery," in IEEE Transaction on Broadcasting, Vol.53, No.2, June.2007, pp.449-458.
- [62] De Rango F., Tropea M., Fazio P., Marano S., "Call Admission Control for Aggregate MPEG-2 Traffic over Multimedia Geo-Satellite Networks," to be published on IEEE Transaction on Broadcasting.



## **Digital Video**

Edited by Floriano De Rango

ISBN 978-953-7619-70-1

Hard cover, 500 pages

**Publisher** InTech

**Published online** 01, February, 2010

**Published in print edition** February, 2010

This book tries to address different aspects and issues related to video and multimedia distribution over the heterogeneous environment considering broadband satellite networks and general wireless systems where wireless communications and conditions can pose serious problems to the efficient and reliable delivery of content. Specific chapters of the book relate to different research topics covering the architectural aspects of the most famous DVB standard (DVB-T, DVB-S/S2, DVB-H etc.), the protocol aspects and the transmission techniques making use of MIMO, hierarchical modulation and lossy compression. In addition, research issues related to the application layer and to the content semantic, organization and research on the web have also been addressed in order to give a complete view of the problems. The network technologies used in the book are mainly broadband wireless and satellite networks. The book can be read by intermediate students, researchers, engineers or people with some knowledge or specialization in network topics.

### **How to reference**

In order to correctly reference this scholarly work, feel free to copy and paste the following:

Floriano De Rango, Mauro Tropea and Peppino Fazio (2010). Multimedia Traffic over Wireless and Satellite Networks, Digital Video, Floriano De Rango (Ed.), ISBN: 978-953-7619-70-1, InTech, Available from: <http://www.intechopen.com/books/digital-video/multimedia-traffic-over-wireless-and-satellite-networks>

# **INTECH**

open science | open minds

### **InTech Europe**

University Campus STeP Ri  
Slavka Krautzeka 83/A  
51000 Rijeka, Croatia  
Phone: +385 (51) 770 447  
Fax: +385 (51) 686 166  
[www.intechopen.com](http://www.intechopen.com)

### **InTech China**

Unit 405, Office Block, Hotel Equatorial Shanghai  
No.65, Yan An Road (West), Shanghai, 200040, China  
中国上海市延安西路65号上海国际贵都大饭店办公楼405单元  
Phone: +86-21-62489820  
Fax: +86-21-62489821

© 2010 The Author(s). Licensee IntechOpen. This chapter is distributed under the terms of the [Creative Commons Attribution-NonCommercial-ShareAlike-3.0 License](#), which permits use, distribution and reproduction for non-commercial purposes, provided the original is properly cited and derivative works building on this content are distributed under the same license.