

RFID System Integration

Hamid Jabbar and Taikyeong Ted. Jeong
Myongji University
 Korea

1. Introduction

This chapter explores the systems and their benefits achieved from efficient RFID system integration. RFID is not a product, its a technology that has opened up a wide range of new opportunity in direct and integrated form for different technical fields and areas. Success key in RFID systems is well defined strategy and results in simple maintenance and easy scalability. Requirement for effective RFID system implementation requires specific RFID products, services and solution which resonate with the business requirement and scale.

RFID systems are integrated with Information and Communication technology (ICT) infrastructure and enterprise systems for automated managerial tasks. One of the key application areas for RFID systems is supply chain management, where they are sometime integrated with barcode readers. RFID system is also used for tracking persons, equipment, work orders, tools etc. RFID is doing, and can do variety of things, alone or in combinations of verity of sensors and sometimes these applications and implementation is not obvious.

Difference between the integrated systems being useful or useless expenses is the proper application of these smart integrated systems. While explaining the RFID system integration this chapter will also discuss the methodology, hardware and software requirements for developing an integrated system.

2. RFID integration benefits

RFID offers many features which make it viable for efficient integration in variety of industrial, consumer and commercial concerns. RFID System Integration requires multi disciplinary collaborating among IT professionals, management, system designer etc. Some problems and lacking in traditional barcode or Unified Product Code (UPC) readers is mitigating migration towards more rich in information; RFID and in some case both technologies are combined to achieve added advantages)[R. G. Paul 2007]. RFID tags, also known as Electronics Product Codes ePCs, generate value due to following

- RFID Codes and unique and generic, it associates and uniquely identifies a manufacturer, an object and specific item with a unique serial number.
- RFID doesn't required visual line-of-sight reading, making it to identify pallets in a box.
- It also offers encrypted read/write capabilities with user required data storage.
- Real-time monitoring using intranet/internet offers inventory control, less waste, tighter supply-chain integration.
- RFID offers automated wireless readable identification system

Source: Radio Frequency Identification Fundamentals and Applications, Bringing Research to Practice, Book edited by: Cristina Turcu, ISBN 978-953-7619-73-2, pp. 278, February 2010, INTECH, Croatia, downloaded from SCIYO.COM

- RFID tags can survive for number of years in harsh environment.
- Several types of RFID tag readers are available such as hand-held's and printers, smart antennas, stationary readers, multi-protocol readers, and others.

3. RFID integration process

For constant flow of information, smooth and efficient processes, value generation using RFID integration with other systems require a comprehensive knowledge and understanding of different systems. Functioning and reliable RFID systems, requires a meticulous knowledge of business, physics and RF system design. To be able to integrate RFID functions within a system and with other technologies such as vision, scan, control and information technologies requires the experience of hardware and technology integration. In applications which requires input of masses such as contact less ticketing, personal verification etc, social and society values and norms also gains important consideration. The contactless data transmission guarantees a high suitability for industrial conditions and large scale implementation.

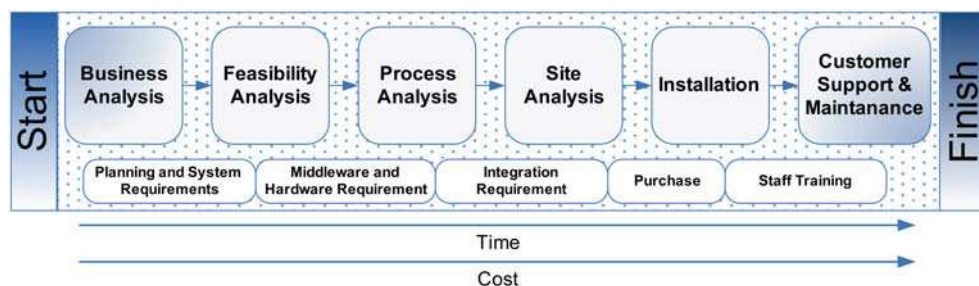

Fig. 1. Process for RFID Implementation and Integration

Each business workflow has its own set of unique requirements and technical hurdles that sets the requirement and customization of RFID system. First, it is important to conduct a business analysis followed by the feasibility analysis of the environment. Usually a conceptual model with thoughtful definitions are set, which help to analyze the process, customer and stakeholders. To conduct the analysis of the sites, small scale test are conducted.

Many companies outsource the implementation to a professional services partner, to reduce possible problems during implementation and their own exposure to risk. To iron out any kinks in the system it is always recommended to accomplish RFID installation in phases, with a test or pilot site. In implementation process every step is checked, re-checked and revisited to improve and tweak the system. In some environments depending on physical proximity the mobile RFID readers are used to enhance or replace stationary models.

One important technical issue in integration process is to diagnose the RF environment for a site, and to install readers and testing tag performance. The types of tag and reader also depend on the type of material which will be identified by tag. In some cases the system requires read/write capability to provide more flexibility to the system. Planning and implementation of reconfigurable, optimized storage, security and authentication are needed so that the reliability of system can be assured.

4. Components for RFID integration

RFID typically compose of reader and tag for the user but mainly it is integrated with other systems to perform the desire tasks. This makes many small hardware or software components, which are considered less thoughtful to gain more importance especially in large scale industrial and commercial applications. This section explains the brief component details which are needed to be considered in RFID system integration.

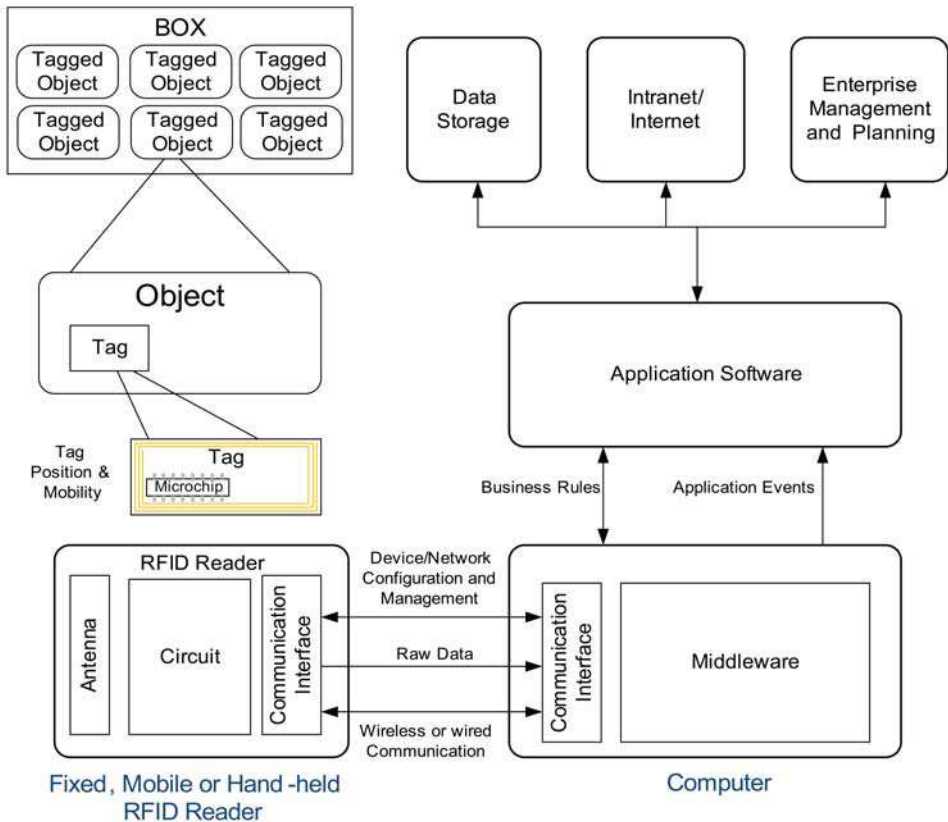

Fig. 2. Main components to consider while RFID and Integration

4.1 RFID tags

Selecting the tags is one the important feature in the integrated systems, as it depends on cost, range, data storage, size, shape, type of material in which tag will be attached. Based on the attachment with identified objects, RFID tags are identified as attachable, implantable, digestible, insertion tags. We also need to decide either to use active or passive tag.

4.2 Tag position and mobility

Two other factors need to be considered for optimal performance while integration is tagging position and mobility. Mobility is important when tag or reader is moving. For

successful identification of tag velocity of movement and change in direction or mobility path also needs to be considered.

Tagging position decides the optimal operation of tag depending on Effective Radiated Power (ERP) which is decisive in case of passive tags. The locations for passive tags depending on ERP are termed as Resonance-Spot, Live-Spot, and Dead-Spot [Adi Tedjasaputra, 2006].

4.3 RFID reader

To decision for RFID reader depends on feature the enterprise, company or customer is looking for. Choice is very broad from simple to intelligent readers, some have self monitoring or integrated software. The size, shape, packaging, power supply are other features which can narrow down the selection for design, customization or purchase of RFID reader. Three general type of readers are hand-held, mobile and fixed readers.

4.4 Reader antenna

The selection for antenna mainly depends on whether the business workflow requires integrated or external antenna. Many application requires the antenna customization to increase speed, accuracy, effectiveness of RFID data capture process. For customization consideration are environmental operating factors, standard compliant, resonant frequency, transponder size, antenna size, the capabilities of the RFID reader module, transponder support, read distance, communication with reader, and its business requirements.

4.5 Communication module

The communication between the reader and server or computer depends on type of connectivity required by the customer, it can be wired communication or wireless. Different protocols and standards are available which depends on type of communication: wireless/wired, range, easiness of installation, cost, connector type, connectivity with existing systems, future updates, security etc. Application requirements and RFID constraints are studied in detail by [Folerkemeier & Lampe, 2005]. Table-1 list the type of communication used in different RFID systems with some specifications.

4.6 Middleware

The middleware captures the raw data from tag, filters it, and aggregates it; to be processed by the software application and it resides in communication server or ordinary computer. In other word middleware is the software translation layer between the RFID reader and enterprise system. The exact definition of middleware is not agreed upon and in many cases it is difficult to separate the middleware from the application software due to the fact that filtering of RFID data can also be performed on the reader before transmitting it to the enterprise network.

The choice of middleware varies from simple data transceiver to intelligence capable which can provide data processing, decision making capabilities. Middleware implements and integrates with application software using standards such as JMS, MSMQ, SMTP, SOAP, UDP, TCP, etc. RFID middleware functions can be broken down as below:

- **Reader Interface:** Middleware implements drivers to receive and/or transmit data from the readers. This also requires the support for plug and play devices.

Standard	Range (m)	Data Rate	Remarks
RS-232	15	20kbps	5 or 9 wire serial communication, discontinuing in new Computers
RS-485	1200	35Mbps up to 10m, 100kbps at 1200m	Two-wire, half-duplex, multipoint, differential serial communication
USB	5	12 or 480Mbps	Most widely used computer peripheral connection method
Parallel (LPT)	6	2Mbytes/s	Decreasing use
Ethernet	100 to 2000	10/100/1000Mbps	Widely used, large range
Zigbee	Between 10 and 75	20, 40, 250 kbps/channel	For wireless application requiring a low data rate, long battery life, secure networking
UWB	10	100-500Mbps	Target wireless sensor data collection, precision locating and tracking information
WiFi	32 to 95	11 and 54Mbps	Wireless technology supported by computers, mobile phone etc.
Bluetooth	1 to 100	1 and 3Mbps	Short range wireless communication
Profibus		31kbps & 12Mbps	Popular fieldbus in process industry
Firewire	4.5	400 -3200Mbps	Wired high speed communication

Table 1. Different Communications standards used today between reader and computer.

- **Data filtering:** Data read from tag can be incorrect or noisy. Data filtering is performed to aggregate, purge and filter data for application layer.
- **Reader Coordination:** One main task of middleware is to provide inventory movement when tags move from one reader to another. Some middleware can process data from multiple RFID readers. Multiple reader reading capability and intelligence in reader is due to advancement in embedded processor technologies but this may add to cost and space.
- **System Monitoring:** To ensure effective and reliable connectivity and real-time views of network and location of tags, monitoring system detects one or more tagged items and publish the event to one or more routers. The software generated events can be tag identifier, reader identifier and a time stamp.

RFID middleware needs to provide configuration or off-the-shelf solution to define business roles for a wide range of business scenarios. Tag reading is inherently unreliable, meaning that a tag that is within an antenna's read field may not be sensed during each and every read cycle. This requires a more elaborate technique for generating tag presence events, such as multiple read for which tag needs to be present for certain time interval.

4.7 Application software for system integration

Application software runs on ordinary PCs or server communicates with the middleware for RFID, controllers and automation equipment data and process them to control workflow and business transactions and pass it to other systems if needed such as Enterprise Resource Planning (ERP) and backend database systems.

RFID systems require software that manages devices, networks, data and processes to enable continual information flow, alerts, decision support and real-time response to an existing host. Application software is usually designed with function libraries, function blocks or drivers for the quick and easy integration into the respective system. Tools, libraries, API's (application programming interfaces) speeds up the integration of RFID equipment in to existing enterprise system regardless of equipment type, manufacturer, enterprise system application or operating environment. This shields system integrators from the details of low-level protocols, standards, and proprietary hardware interfaces, providing instead a single API for a wide range of hardware.

4.8 Data storage server

Using appropriate networking infrastructure systems, the data obtained by middleware and application can be stored and used for developing, deploying and servicing productivity solutions.

The central server runs a database application, with functions that include matching, tracking, and storage. The software runs on ordinary PCs or servers for a backend database system (e.g., Oracle, SQL Server, Postgres, MySQL) for storing information about the tags. The presence of a robust TCP/IP stack and the availability of SQL database engines greatly reduce an otherwise major integration burden in the development process. In many applications, an alarm or alert function is also present to re-order, for supply chain and inventory management systems, or an alert to a guard, for security applications.

4.9 Enterprise management and planning connectivity

To extracting knowledge from large volume of data, enterprise and higher level management and planning applications are usually developed especially in large scale companies. These software performanalyze supply chain magement, Productivity growth, operational superiority and competitiveness.

4.10 Security

While managing number of hardware devices, large volume of data with high speed the biggest risk is security of the data and inventory. Deployment of RFID is usually by leveraging existing IT infrastructure which provides security protocols, secure communication, protected database and authorized services and secure transactions. All components have built-in functionalities that can have pre-defined business rules to execute relevant transactions at business levels.

To derive a business event and execute a business transaction, especially money transaction requires high level of security at software as well as at tag level. Validation and verification services are implemented to get best value from application.

In addition, our cryptography knowledge provides us with the capability of risk and threats analysis. Cryptography techniques are used in RFID for tag identification and security and to secure them from attacks [Karthikeyan & Nesterenko (2005)].

5. Regulatory compliance testing and standards

In integration process and while desiging a prodcut certain regulatory compliance needs to be taken underconsideration for product safety, EMC testing and certification for the major world markets standards.

Region	Electromagnetic compatibility (EMC) and Safety Standard
U.S.	EMC - FCC Rule Part 15 or 90 Safety - UL 60950 for Tag Interrogators and NRTL Certification
Canada	EMC - RSS-210 Safety - CSA 60950 and SCC Certification Body
Europe	EMC testing in accordance to ETSI EN 301 489-1 and ETSI EN 301 489-3 Radio testing in accordance to ETSI 300-220 Safety testing in accordance to EN 60950 Declaration of Conformity for CE marking requirements
Asia	

Table 2. Product safety and EMC testing and certification for the major world markets.

RF conformance tests are critical to assure reliable interoperability among tags and readers. Also the tags and readers also follow the standards such as ISO (International Standards Organization) and IEC (International Electrotechnical Commission).

Standard	Description
ISO-18000	Air Interface frequencies
ISO-15961/62	Data protocols and encoding
ISO-15963	Unique Tag Id
ISO/IEC-18046	RFID tag and interrogator performance test methods
ISO/IEC-18047	RFID device conformance test methods

Table 3. ISO and IEC standards for RFID

Electronic Product Code Information Services (EPCIS) standard provides a data model for tracking events, including shipping and receiving of uniquely identified objects, as items move through the supply chain. ISO standard for supply chain are also available such as,

Standard	Description
ISO-17358	Application Requirements, including Hierarchical Data Mapping
ISO-17363	Freight Containers
ISO-17364	Returnable Transport Items
ISO-17365	Transport Units
ISO-17366	Product Packaging
ISO-17367	Product Tagging (DoD)
ISO-1734.2	RFID Freight Container Identification

6. Example: RFID integration with IPTV for viewer identification and authentication

For parental control, we can specify how much time children can play games, restricting his channels and viewing time with reminders and memos added in menus [Jabbar; Jeong 2008]. As shown in Figure-3, the RFID reader can be directly connected to the STB using the serial port; if a serial port is not available a USB port can be used for the purpose. The STB should be programmed to identify the Reader with plug and play capabilities and load its driver.

After the successful installation specific menus can be downloaded from the server by Electronic Program Guide (EPG). The menus will guide the user for specific input from his RFID tag and will keep track of all his activities.

Server can be assigned task such as the encryption, authentication, program installation, user profiles, user contents etc.

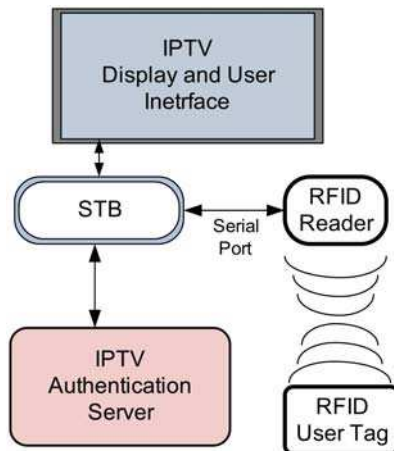

Fig. 3. System Interface for IPTV

6.1 Data transmission

For the testing purposes the RFID serial communicating device was supposed to be detected by the STB. No service label was shown on screen using Java Xlet if the RFID reader was not connected with the STB. After the device detection the user specific menus were loaded from the server as shown in Figure-6 and Figure-7, respectively.

STB middleware was given some file handling and sharing capabilities. Whenever a user was identified by the STB, the java Xlet wrote down a file in a specified format. It was supposed initially that only two account are of super-users and rest are made by the viewers or user, like the children accounts were made by the parents, a guest account option can also be created. A file contain the information related to the user

- Name of the user
- User Type
- Favorite Channels
 - Channels Viewed Last Time
 - Favorite Channels List
- History
 - Previous Videos On demand
 - Channels list
 - Pay per View Orders
- Parental Control
 - Allowed/ Not allowed
 - Time allowed to watch TV
 - User Name

- Other Settings
 - Transaction allowed or not
- Personal Profile
 - New User Settings
 - Profile Updates
- Shopping
 - RFID card Verification
 - Make Payment

Whenever the viewer was identified by the STB, the file containing the above information was requested from the server. The server transfers the file to the STB which store the file temporarily and keeps on updating the file, the Xlet was programmed for file read/write operation and when user exits from the menu or STB was turned off the file was saved and transferred to the Server for storage.

Type of file		File size (Kbyte)	Transmission Time (sec)	Viewer Identification Time (sec)
video	.avi	398	486	0.87
	.asf	450	504	1.23
audio	.wav	246	232	0.34
	.wmv	234	239	0.43
	.midi	198	212	0.25

Table 4. Test Results of Data Transmission

Table 4 shows that test results of STB design which includes some parameters such as file type, file transmission time and viewer identification time. The viewer identification time means that duration of waiting time before the file actually identified from the Server on TV screen.

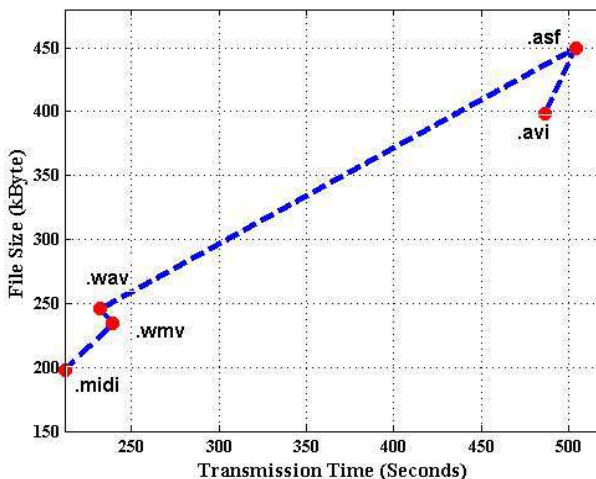

Fig. 4. File transmission time vs. File size

From the test results, we found that video files takes more time to transmit than audio files because of file size, and also viewer identification time is very little after we finally implemented RFID technology with IPTV interface.

The viewer IPTV contents were saved in the server and when required by the viewer after authentication was transmitted to the viewer. The transmission time taken by different media contents, video and audio with file size is shown in Figure-5.

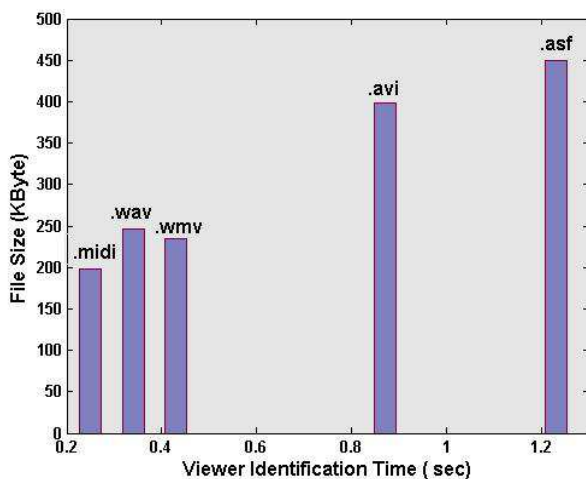

Fig. 5. Viewer identification time vs. File size

Before some secured contents to be transmitted, the viewer was again required to identify and authenticate himself. The time taken by the server to identify the viewer for specific media content size is shown in Figure-5.

6.2 Screen display

Application is an application that is powered by a Presentation Engine (e.g. HTML Browser, Flash) and it support interactive services such as EPG, VOD, games, news, etc. For this case the application layer was EPG and through server Java Xlet based menus and applications were loaded in to the STB for viewer experience as shown in Figure-7.

Although RFID has found much application, one good example in consumer electronics is the integration of RFID system with Internet Protocol Television (IPTV). The system combines the RFID reader, IPTV Set-up-Box, IPTV server, payment server and data storage. Main purpose of such system is to authenticate and identify the Viewer of IPTV for parental control, payment, media storage, and other features offered by the IPTV.

7. Example: RFID integration with Programmable Logic Controller (PLC)

Programmable logic controller (PLC) is a specialized industrial computer used for automation of real-world processes. Most of the leading processes, oil and gas, food, beverage, and similar manufacturing companies have sophisticated automation systems in place that control the high-speed packaging lines in their manufacturing operations and



Fig. 6. (a) IPTV Viewers Identification Screen Capture (b) Experimental Platform with Screen Capture and Display.

high-speed conveyors in their distribution facilities. These systems are typically controlled by Programmable Logic Controllers (PLCs), which are dedicated automation systems programmed and maintained by electricians or technicians.

As RFID becomes more ubiquitous, is integrated with the mainstream production process with PLC-centric architecture enabling engineering managers to maintain and upgrade the incremental RFID infrastructure using their existing personnel skill set. One such technique is utilized to trace fish in supply chain by [Hsu et. Al (2005)].

RFID is widely adopted in Automotive industry. An RFID tag is attached to each vehicle or skid and programmed in production line, this data can be read out and processed directly by means of a PLC. At each manufacturing station, this data is remotely read out by the PLC and then processed to control the production step with PLC updating the data or status information on the RFID tag at end of each station.

7.1 RFID interface with PLC

For interface with PLC, RFID reader has to communicate with standard module which can be plugged in to the backplane of PLC rack. Usually module communicates data between the RFID Tags and the host PLC via a simple ladder logic program in the PLC. The program in module offers normal operations such as Reading and Writing to a Tag and returning status of operations to the PLC. Serial port is usually available with such modules to download and debug the software. These industrial modules are designed to read/write multiple RFID readers, some have ports for antenna and reader resides in module. To have compatibility with PLC system, the module has 24VDC supply.

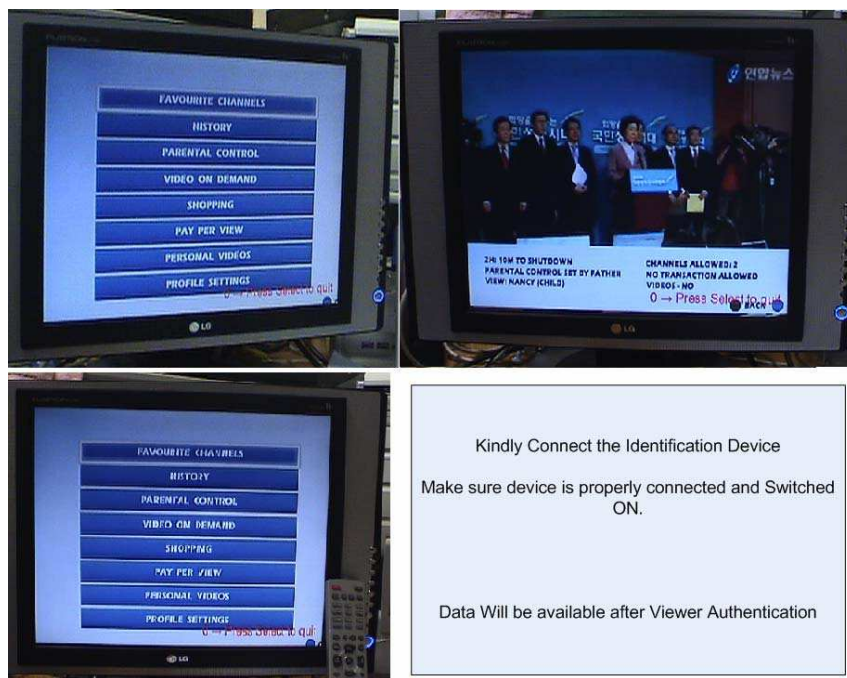

Fig. 7. Screen showing the Interface for users and Menus displayed on IPTV

8. Example: RFID based guidance and object detection for blind and visually impaired persons

Many RFID, image, robots type devices are coming in the market which employs the high tech technology and excellent features to help the blind and visually impaired people [1]. No doubt the devices and features are extraordinary and when developed as a system can help lot many of the visually impaired people of the society. But few are there who are of the low cost. The main requirement to develop a low cost device is because the 90 percent of the blind and visually impaired people in world belongs to the developing countries. Majority of these people cannot afford this costly equipment and most government and institutes in developing countries cannot develop and maintain the system to help the visually impaired people.

This paper presents an idea by going further, taking inspiration from the simple low cost Ubiquitous RFID technology developed for the blood distribution system. First we have shown how the RFID reader developed for blood distribution system can be used for detecting the objects and path for the guidance of blind and visually impaired person. Then we purposed some hardware changes in the system to make it an effective guidance and object detection product by keeping the cost at minimum.

The system consists of short range passive type RFID transponder and receiver developed already and proposed new added hardware. The design of the system needs to be simple and easy to use keeping in mind the low literacy rate and easy system maintenance. When develop this system can be used at an individual home, schools, public places and can become an integral part of the Ubiquitous health care system.

Tags are fitted in to the objects and are programmed to transmit when they are in the interrogation range of the reader. The object tag transmits its data or identification number when the RFID reader is brought near the 140mm area of the tag; object was identified by watching its Identification number in the computer application. As soon as the reader was brought out of the identification area the communication with the tag was lost. Moving the reader away to another object with tag embedded in it, we were able to identify the object using that object Identification number in the computer application. Figure-3 explains the process of object and path detection mechanism.

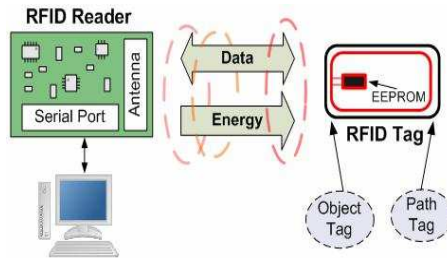

Fig. 9. Object and Path Detection between RFID Reader and Tag

For the path tracking and guidance the tags can be fitted or stick to the carpet or floor respectively. The distance between the tags needs to be greater than twice the interrogation range, greater than 280mm in our case to avoid collision. This was done because the tags used for path or tracks recognition has the same number except the corners. This was done to keep the system simple and easy to identifiable by the user.

8.1 Proposed RFID detection system

Modifying the above system with already existing hardware and techniques, we can easily make the system to perform the tasks of object detection and path tracking together and informing the person using his/her sense of listening through headphone. Achieving above can make a cost effective, easy to use guidance system for the blind and visually impaired person. With some practice this new system can perform well under certain specifies conditions.

8.2 Proposed hardware changes

The new purposed system consists of four antennas, which are fitted in each hand and feet of the person. To make the cost lower and the system simple we prefer to use one RFID reader and all the antennas communicate with the reader through wires. The speech or voice output can be achieved by using the techniques used in the "Talk Aid" or "An Affordable Digital-Display-to-Natural-Voice Converter for Visually Impaired Radio Amateurs", both the technique employs the PIC microcontroller. New technique requires a microcontroller with greater memory, PIC16F84 memory is of only 64 bytes and it is not enough to store the different tags and there corresponding object names. In this case other microcontroller can be choosing from the PIC microcontroller series.

The system works by keeping in mind its short reading range. Figure 4 explains the block diagram of new proposed system with location of tag and reader on human body. The tag programming is easy using the computer and via serial port reader can programme the tag EEPROM. The Analog Switch (or Analog Multiplexer) can be used to switch between the different antennas, by switching the different antennas in regular interval we can detect the

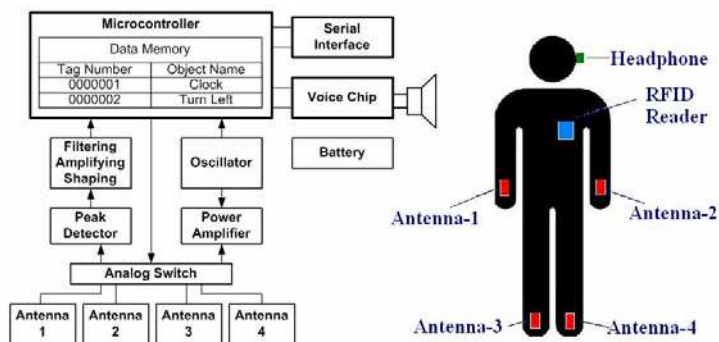

Fig. 10. Block Diagram of Proposed New Detection Methodology

tag in each antenna's interrogation range, this will also make the reader to continuously speak out the object name in range after the specific interval. A comparison table can be made in the internal microcontroller memory or in external memory within card if used to locate the object name using the tag identification number. After locating the object name, a specified sequence of signal can be used to generate the sound to inform the person about the object. A battery can be used to keep the system working all the time. Reader can be designed to fit in the pocket of the person.

8.3 Object detection technique

The antennas in the hands can be worn using the straps as shown in the Figure 5. For the objects detection a person can take out his hand and by moving his hand in one direction all the objects which will be in the interrogation zone of the hand will start to communicate with the reader, as soon as the hands will leave the interrogation zone the communication will be stopped and using his direction of hand, person can get the idea where the object is. As the distance between the object and hand is small, 140mm, accurately catch the object won't be difficult also as the reader will keep on calling the object name with certain interval, person can smoothly reach the desire object. Using both the hands and moving them slowly and listening to headphone all the object distance and position can be estimated by the blind and visually impaired person thus giving him the picture of his environment.



Fig. 11. Object Detection Examples

8.4 Path detection technique

The antennas can be fitted in the shoes. For the path tracking the 1-bit tags can be used in the paths. This means that only two information can be represented by system based upon a

1-bit tag: “tag in interrogation zone” and “no tag in interrogation zone”[2]. Reader will just transmit BEEP signals via headphone to inform the person that he is going in the right path. As soon as the person will go off the track the BEEP will stop telling him, he is away from the track and he can step back to follow the path again. Tags are to be placed in such a way that the interrogation areas of the tags don't interfere with each other to avoid collision as shown in Figure 6. Identifiable tags can be used in the turning and at the stairs. Railing and the walls can be fitted with the tags so that the hand and feet tags can coordinate well in walking.

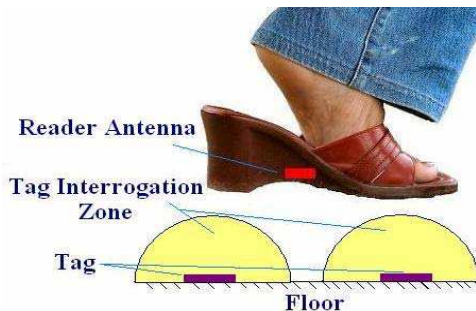

Fig. 12. Path Detection Methodology

Tags are to be placed in such a way that the interrogation areas of the tags don't interfere with each other to avoid collision as shown in Figure 6. Identifiable tags can be used in the turning and at the stairs. Railing and the walls can be fitted with the tags so that the hand and feet tags can coordinate well in walking.

8.5 Cost estimation

Globally, in 2002 more than 161 million people were visually impaired, of whom 124 million people had low vision and 37 million were blind. Visual impairment is unequally distributed across age groups. More than 82% of all people who are blind are 50 years of age and older, although they represent only 19% percent of the world's population. Due to the expected number of years lived in blindness (blind years), childhood blindness remains a significant problem, with an estimated 1.4 million blind children below age 15. Visual impairment is not distributed uniformly throughout the world. More than 90% of the world's visually impaired live in developing countries.

The cost is one of the main issues in developing the RFID system for Ubiquitous-Healthcare. Because this system is designed for the low income people it cost need to be of lower price. A large production volume will make possible to lower the price as well. The system is developed by keeping the number of components minimum and of the low cost. Tags purposed are the lower cost especially the 1-bit tags, person can buy the number of tag according to his need and price. Greater the number of tags will be the environment impression and realization.

The previous developed RFID blood system cost around \$150 and keeping in view the cost of new microcontroller, antennas, battery, headphones the approximate cost of the new system is estimated to be around \$200. By choosing some standard systems and mass production of these system can greatly reduce the cost for the people still waiting for desire help.

9. RFID integration basic theory

One other example - RFID system composes of two parts reader and transponder or tag as shown in Figure-13. The magnetic field, generated between reader antenna coil (primary coil) and tag antenna coil (secondary coil), transmits powers from reader to tag and data both ways. Reader RLC serial resonance type circuit supplies enough energy using small voltage to generate voltage in tag to enable it for transmitting its data. The resonance frequency, f_0 and f_B of the circuit are shown in Equation 1 and Figure-9.

$$f_0 = \frac{1}{2\pi\sqrt{L_R C_r}}, f_B = \frac{f_0}{Q_R} \tag{1}$$

Frequency of the signal V_D for the reader coil is required to match with the resonance frequency f_0 . At time of resonance the voltage on each end is $V_R = Q_R V_D$. Here, Q_R in Equation 2 is the Q factor of reader coil.

$$Q_R = \frac{2\pi f_0 L_R}{R_R} \tag{2}$$

If Q_R gets too small the voltage of reader coil V_R becomes too small so the energy transferred to the transponder also reduces, hence, the recognition distance gets smaller.

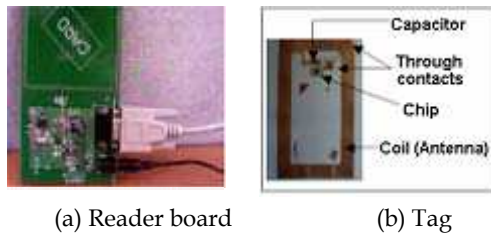

Fig. 13. The Reader and Tag of RFID System

Using front-end impedance modulation method we modulate impedance on each end of the coil depending on the data that it wants to transmit using the Damping circuit. Therefore the voltage on each coil end will change and this leads to the impedance change on reader antenna. And the change in voltage will be detected in the reader section.

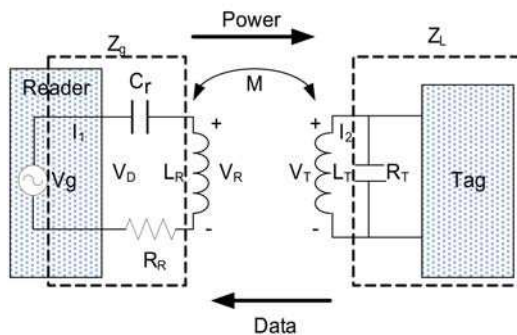

Fig. 14. Basic Inductive Coupled Circuit

In Table 1, the variables related to inductive coupled circuit in Figure-8 are arranged. Z_{11} is total impedance of reader circuit when the tag circuit is open and Z_{22} is impedance of tag circuit when the reader circuit is open. M is mutual inductance that expresses the coupling level between two coils and the relationship with coupling coefficient, k , is shown in the table.

Z_{ab} is driving-point impedance and Z_r is coupled impedance that is created by coupling with tag circuit. Z_r is also called as reflected impedance. When the power V_g is impressed the flow of electric current I_1 is created. By mutual inductance the voltage, V_T is induced in the tag circuit.

$Z_{11} = sL_R + Z_g$	$Z_{12} = sM$	$Z_{21} = sL_T + Z_L$
$Z_{ab} = L_{11} + Z_r$	$Z_r = -\frac{Z_{12}^2}{Z_{22}}$	$M = k\sqrt{L_R L_T}$

Table 5. The Variables related to Inductive Coupled Circuit

The electric current, I_2 in the tag circuit is created by the induced voltage and, with this current; I_2 the voltage in the reader circuit is induced again.

$$I_1 = \frac{V_g}{Z_{ab}} = \frac{V_g}{Z_{11} + Z_r}, \quad I_2 = -\frac{Z_{12}}{Z_{22}} I_1 \quad (4)$$

$$V_R = sL_R I_1 + sM I_2, \quad V_T = sM I_1 + sL_T I_2$$

Summarization of the formula for voltage and current that was derived using Equation. 4 and the variables is shown in Table 5.

10. Trends in RFID system integration

With emergence of 2-D DataMatrix barcode solution, wireless barcode reader and lower cost of barcodes as compared to RFID tag, current and future trend is the continuation of co-existence of RFID and barcode technologies.

RFID represents research, technology as well as big business opportunities. The RFID readers should become 100% reliable (at present they are typically between 80-95% reliable, depending on environmental conditions) to be able to capture the entire market [R. G. Paul 2007]. One of the major advantages in RFID is the easiness in integration of RFID reader with any type of emerging and current communication standards.

With increasing research and solutions it is expected that future will see increase in proximity scanning, convergence toward standards, processing of all material type and in all type of environment of RFID technology.

11. Conclusion

Radio Frequency Identification (RFID) is finding many applications and ways to help the disable people, and relation with consumer electronics, i.e., IPTV, and/or PLC, etc. As we have a significant benefit of cost, RFID technology can be used in Ubiquitous Network system including Healthcare, Transportation, and Consumer market. This technology can be utilized in any places such as schools, market and road to help and guide the blind and visually impaired people and authorize his/her identification.

Product design is based on the RFID reader and tag communicating at 13.56MHz with RFID reader RS-232 serial port as the interface for STB as an example of usage. The tag contains a reprogrammable memory and works without a battery. Radio Frequency from the Reader triggers and power up's the tag for communication.

With ever increasing applications of RFID in human life, we have connected the RFID systems we developed with IPTV STB. In which Viewer, the person who is watching the TV is identified and authenticated using RFID tag wirelessly.

The IPTV STB transmits this information to the server for authentication, verification, and identification of the viewer with the tag he owns. Already existing RFID tag's like office or ATM or Mobile phone based RFID tags can also be used. As compare to Digital TV, Data storage and e-commerce based applications in IPTV requires the viewer authentication to access network feeds, stored media, communication links and live studio sources, shopping etc. System and device presented is of more interest of Service Providers, who can use the system presented to safely operate their IPTV systems, also the systems requires easy maintenance.

For future compliance with STB's a USB interface is required with RFID reader. The major drawback is that person might needs to move from is sitting place to get himself authenticated for some features, causing inconvenience, this can be avoided using long range reader or implementing RFID reader in remote control.

12. References

- Paul, G. R. (2007). Engineering Management-Focused Radio Frequency Identification (RFID) Model Solutions, *IEEE Engineering Management Review*, vol. 35, no. 2, Second Quarter, 2007, pp 20-30, ISSN: 0360-8581
- Qiu, R. G. (2007). RFID-Enabled Automation in Support of Factory Integration, *Robotics and computer-integrated manufacturing*, 16th International Conference on Flexible Automation and Intelligent Manufacturing, vol. 23, no.6, December 2007, pp. 677-683
- Cox, Jr.; George, D. T. (2007). System and method for RFID System Integration, *Unites States Patent, US 7267275 B2*, Date of patent Sep. 11, 2007
- Folerkemeier, C.; Lampe, M. (2005). RFID middleware design - addressing application requirements and RFID constraints, *Proceedings of SoC-EUSAI 2005 (Smart Objects Conference)*. Grenoble, October 2005
- Karthikeyan, S.; Nesterenko, M. (2005). RFID Security without Extensive Cryptography, *The Third CCS ACM Workshop on Security of Ad Hoc and Sensor Networks (SASN'05)*, pp. 63-67, Washington, DC, USA, November, 2005
- Hsu, Y. C.; Chen, A. P.; Wang, C. H. (2008). A RFID-enabled Traceability System for the Supply Chain of Live Fish, *IEEE International Conference on Automation and Logistics, ICAL 2008*. Qingdao, China, 1-3 Sep, 2008, pp. 81-86
- Jabbar, H.; Jeong, T.; Hwang, J.; Park, G. (2008). Viewers Identification and Authenticaion in IPTV using RFID Technique, *IEEE Transactions on Consumer Electronics*, vol. 54, no. 1, pp. 105-109, Feb. 2008.



Radio Frequency Identification Fundamentals and Applications Bringing Research to Practice

Edited by Cristina Turcu

ISBN 978-953-7619-73-2

Hard cover, 278 pages

Publisher InTech

Published online 01, February, 2010

Published in print edition February, 2010

The number of different applications for RFID systems is increasing each year and various research directions have been developed to improve the performance of these systems. With this book InTech continues a series of publications dedicated to the latest research results in the RFID field, supporting the further development of RFID. One of the best ways of documenting within the domain of RFID technology is to analyze and learn from those who have trodden the RFID path. This book is a very rich collection of articles written by researchers, teachers, engineers, and professionals with a strong background in the RFID area.

How to reference

In order to correctly reference this scholarly work, feel free to copy and paste the following:

Hamid Jabbar and Taikyeong Ted. Jeong (2010). RFID System Integration, Radio Frequency Identification Fundamentals and Applications Bringing Research to Practice, Cristina Turcu (Ed.), ISBN: 978-953-7619-73-2, InTech, Available from: <http://www.intechopen.com/books/radio-frequency-identification-fundamentals-and-applications-bringing-research-to-practice/rfid-system-integration>

INTECH

open science | open minds

InTech Europe

University Campus STeP Ri
Slavka Krautzeka 83/A
51000 Rijeka, Croatia
Phone: +385 (51) 770 447
Fax: +385 (51) 686 166
www.intechopen.com

InTech China

Unit 405, Office Block, Hotel Equatorial Shanghai
No.65, Yan An Road (West), Shanghai, 200040, China
中国上海市延安西路65号上海国际贵都大饭店办公楼405单元
Phone: +86-21-62489820
Fax: +86-21-62489821

© 2010 The Author(s). Licensee IntechOpen. This chapter is distributed under the terms of the [Creative Commons Attribution-NonCommercial-ShareAlike-3.0 License](#), which permits use, distribution and reproduction for non-commercial purposes, provided the original is properly cited and derivative works building on this content are distributed under the same license.