Power-Over-Fiber Applications for Telecommunications and for Electric Utilities

Joao Batista Rosolem

Additional information is available at the end of the chapter

<http://dx.doi.org/10.5772/68088>

Abstract

Beyond telecommunications, optical fibers can also transport optical energy to powering electric or electronic devices remotely. This technique is called power over fiber (PoF). Besides the advantages of optical fiber (immunity to electromagnetic interferences and electrical insulation), the employment of a PoF scheme can eliminate the energy supplied by metallic cable and batteries located at remote sites, improving the reliability and the security of the system. Smart grid is a green field where PoF can be applied. Experts see smart grid as the output to a new technological level seeks to incorporate extensively technologies for sensing, monitoring, information technology, and telecommunications for the best performance electrical network. On the other hand, in telecommunications, PoF can be used in applications, such as remote antennas and extenders for passive optical networks (PONs). PoF can make them virtually passives. We reviewed the PoF concept, its main elements, technologies, and applications focusing in access networks and in smart grid developments made by the author's research group.

Keywords: power over fiber, PoF, fiber powering, sensing, monitoring, photovoltaic converters, smart grid, fiber to the antennas

1. Introduction

Optical fiber (OF) technology has many decades of research and development mainly focused in telecommunication applications. Other classical applications for optical fibers include sensors, endoscopic imaging, and illumination.

Decades ago, in the 1970s, scientists of American Telephone and Telegraph (AT&T) had the idea to use the fiber to supply energy using optical fiber to make a sound alert in telephones, instead of the electric option. The concept of power over fiber (PoF) [1] was born this way. In

other words, beyond their classical applications, optical fibers can also be used to transport optical energy to powering electric or electronic devices remotely. This is the concept of PoF.

Since that time in the 1970s, many applications have emerged for PoF mainly in two different areas: telecommunications and utilities.

Why PoF is interesting? The reasons depend on the applications but they are associated to the optical fiber characteristics.

For telecom applications, the key factors are (i) PoF eliminates the necessity of batteries, solar panels, and long copper feeder wires in the remote sites, improving the reliability and the security of the system; (ii) PoF permits the reduction of the space and the installation cost in remote sites, which is very important to telecom companies.

For electrical utilities, there are at least four key factors: (i) PoF uses optical fiber, which is made of nonconductive material. This characteristic is important because in most applications in electrical world, the sensors are placed in high voltage. Any conductance in high-voltage elements can create current leaks; (ii) optical fiber is immune to electromagnetic interferences. The electrical world environment is polluted of electromagnetic interferences; therefore, optical fiber can transmit signals without quality degradation; (iii) the optical fiber eliminates the need to run conductive copper wire into a high-ground potential rise (GPR) zone. GPR arises when lightning strikes occur in substations and can cause severe interference problems in electronic equipment and systems. Considering that the sensor using PoF has a complete galvanic isolation to the ground potential, it is practically immune to the GPR effects; and (iv) there are many low-cost/low-power/high-efficiency electronic sensors available for transmission lines and substations monitoring that can be supplied by PoF without incurring in the described problems.

This chapter describes a revision of PoF, its technical principles, main elements, technologies, and the applications in telecom and in utilities, developed by the author's group.

2. Power over fiber

This section presents the technical principles of PoF including a short history, the main elements (high-power lasers, fibers, and photovoltaic converters (PVs)), and their main limitations (laser power, converter efficiency, and fiber-fuse effect), circuits, topologies and networks, application on multimode (MM), single mode (SMF) and special fibers, and finally the future perspectives.

2.1. Historical overview

2.1.1. Telecom

The concept of PoF was born together with the first optical fiber developments. Optical fiber with low attenuation (less than 20 dB/km) was developed in 1970, and the first fiber optic

link was installed in Chicago in 1976, USA. To the best of author's knowledge, DeLoach et al. [1] published the first work about PoF in 1978. They proposed to use PoF to operate a sound alert of a telephone remotely. Continuing the previous experiment, in 1979, Miller and Lawry [2] implemented a two-way speech communication between an electrically powered station and an optically powered station, and in 1982, Miller et al. [3] demonstrated a bidirectional speech-television communication over a single optical fiber, with emergency optical powering of the remote station telephone. A great result of those researches was the development of a highly efficient photovoltaic converter based on GaAlAs.

In 1993, Banwell et al. investigated the issues of PoF application in fiber-in-the-loop (FITL) [4]. In this work, many technical and cost aspects have been considered in the analysis. Almost a decade after that, Miyakawa et al. [5–7] presented fiber optic power and signal transmission systems considering the application of DC (direct current) powering to information equipment such as personal computers.

Werthen and Cohen [8] in 2006 and 2008 [9] proposed the use of PoF for driving low-power switches or actuators to assuring path diversity in upstream data delivery in passive optical network (PON) architectures and for providing battery backup power in case of power outages.

In 2007, Wake et al. [10] studied the combination of radio over fiber and PoF, and in [11], they described optically powered radio-over-fiber remote units designed and constructed for distributed antenna system applications.

Sato and Matsuura [12] and Matsuura and Sato [13] demonstrated in 2013 the transmission of RF signal and high-power light using a double-clad fiber (DCF). A DCF has a single-mode core and a multimode inner clad. The RF signal and the optical powering signal travel, respectively, through core and in the inner clad of DCF.

In 2014, Penze et al. [14] proposed powering PON extenders using PoF. In this research, SOAs (semiconductor optical amplifier) were powered using PoF. The SOAs were used in a bidirectional amplification of signals of Gigabit PON (GPON) and 10 Gigabit PON (XGPON). In the same year, Ikeda [15] proposed a PoF instead of metal waveguides in order to protect microwave radio equipment from lightning.

Yan et al. [16], in 2015, developed a wireless sensor system based on PoF to realize a flexible distributed sensing over a middle distance, in environments of high voltage, strong magnetic field, flammable, and explosives. In the same year, Matsuura and Sato [17] demonstrated experimentally a bidirectional radio over fiber using a DCF for optically powered remote antenna units. The feasibility of the technique was demonstrated by bidirectional RoF transmission over a 100-m DCF optically feeding with 4.0 W, and in [18], Sato et al. demonstrated a bidirectional radio-over-fiber transmission using a double-clad fiber with 40-W optical power feeding. In the same year, Lee et al. [19] described the concept of cloud radio access network (CRAN) based on PON exploiting PoF, and Suto et al. [20] detailed the challenges of QoE-guaranteed and power-efficient network operation for CRAN based on PON exploiting PoF.

In 2016, Minamoto and Matsuura [21] and Matsuura and Minamoto [22] presented an optically controlled beam steering system using 60-W PoF in the fiber to feed remote antenna

units, and in [23], Yoneyama et al. demonstrated a 1.3- μm dual-channel radio-over-fiber system using a 300-m double-clad fiber feed with 30-W optical power of a PoF system. In the same year, Umezawa et al. [24] reported a high-conversion gain in a high-speed optical receiver based on PoF supply and designed to work with radio over fiber at 100-GHz region. In [25, 26], the same authors proposed the use of a multicore-based radio and PoF in a transmission using a 100-GHz photo receiver.

2.1.2. Utilities and other industries

In 1980, Caspers and Neumann [27] first described a PoF method used to supply active electronic circuits at high potential. In the experiment, they used four infrared light-emitting diodes (LEDs) emitting at a wavelength of 940 nm which were connected in parallel and coupled to an uncladded glass rod of 40-mm diameter and a length of 1 m with an attenuation smaller than 200 dB/km at a wavelength of 850 nm. Four square silica solar cells of 20 mm length were connected in series in this experiment.

Ohte et al., in 1984 [28], demonstrated a transducer with optical-fiber data link to provide electrical isolation. A pulse-position-modulated optical signal was used in transmitted signal by optical fiber from a remote converter to mainframe. Wavelength division multiplexing (WDM) was used to transmit the modulated signal and the optical feed power in the same optical fiber.

In 1988, Trisno and Wobschall [29] described a method for improving the efficiency of the conversion of pulsed optical power to electrical power by photovoltaic. The system required a pulsed power source with a storage capacitor to hold energy for a time after the optical power is turned off. In the same year, Bjork et al. [30] demonstrated the ability to provide data communication a variety of off-the-shelf electronic transducers in a single fiber with proper attention to the synchronization issues and in [31] Lenz and Bjork presented a comparative study of four concepts for standardizing and multiplexing of fiber optic sensors for aircraft applications and compared them with PoF.

Kirkham and Johnston [32] presented in 1989 an optical frequency-modulated (FM) data link whose remote electronic sensors were optically powered. An application to current measurement is described in a high-voltage line by means of a linear coupler.

In 1991, Yamagata et al. [33] described a PoF system to measuring gas density of extra high-voltage substation gas-insulated switchgear. This system employed a method of matching the impedances of load and photodiode by optical electrical conversion of pulsed light with a photodiode and boosting the voltage with a transformer. In [34], Sai presented an optimization of this method. In the same year, Nieuwkoop et al. [35] described an alternative system to increase the voltage to the remote sensor using a low-cost coil.

Spillman and Crowne [36] presented in 1995 a throttle level angle (TLA)-sensing system applied to aircrafts utilizing a capacitance-based rotary position transducer which was powered and interrogated via light from a single MM optical fiber. The system used a unique GaAs device that served as both a power converter and optical data transmitter. In the same year, Tardy et al. [37] described a PoF system designed to measure current in high voltage;

Pember et al. [38] demonstrated a PoF network concept; and Dubaniewicz and Chilton [39] described a PoF system to gas monitoring in mines.

In 1996, Werthen et al. [40] presented an optically powered current transducer based on shunt technology using PoF and detailed a practical use of this technique. Wang et al. [41] and Zhijing [42] detailed the use of PoF to measure the pressure of liquids in 1998. In 2005, Turán et al. [43] review the basic properties of PoF, their key elements, and its industrial applications.

Bottger et al. [44], in 2008, presented an optically powered video camera link that allows acquiring and communicating a 100-Mb/s video stream over a distance of hundreds of meters. In [45], M. Roger demonstrated an optically powered sensor network with subscribers consuming less than 1- μ W average power, and an optically powered high-speed video link transmitting data at a bit rate of 100 Mbit/s.

In 2010, Rosolem et al. [46] described the results of a PoF sensing system for monitoring partial discharges on hydro generators and de Nazaré and Werneck [47] proposed a monitoring system based on PoF to measure the temperature and current of transmission lines.

Audo et al. [48], in 2011, proposed PoF-based architecture to extend multidisciplinary-cabled networks or to create a dedicated submarine hydrophone or seismometer network, and in 2012, Lau et al. [49] reported a prototype optically remote-powered subsea video monitoring system that provides an alternative approach to powering subsea video cameras. In the same year, Tanaka and Kurokawa [50] presented a review of fiber optic sensor network that employs PoF. A hybrid sensor network with wireless sensors is also achievable by introducing wireless/optical interface nodes.

In 2014, Rosolem et al. [51] presented a PoF system to long-distance applications based on charge/discharge of super-capacitors. The system was installed in a transmission line tower, and it was connected to the substation using an optical ground wire cable (OPWG), and in [52], Silva et al. proposed a new MM fiber optic cable to transmit optical energy for long reach in PoF systems.

Rosolem et al. [53], in 2015, presented the results of a PoF system to monitor high-voltage switchgear using video cameras and free space optics (FSO), and in [54], Rosolem et al. proposed the use of PoF and FSO to measure current in high-voltage transmission lines.

In 2016, Zhang et al. [55] proposed a 15-kV silicon carbide (SiC) MOSFET gate drive using PoF and replaced the traditional design based on isolation transformer.

2.2. Technical principles of PoF

A generic PoF system is shown in **Figure 1**. In the left side, the control unit composed by the high-power optical source (HPOS) unit together with the optical reception unit (ORU) is shown, which receives signals from the remote sensor unit, shown on the right side of **Figure 1**. Two optical fibers connect the local control unit to the remote unit. The optical fibers may be standard SMF optical fibers or MM fibers. In the remote unit, a photovoltaic converter

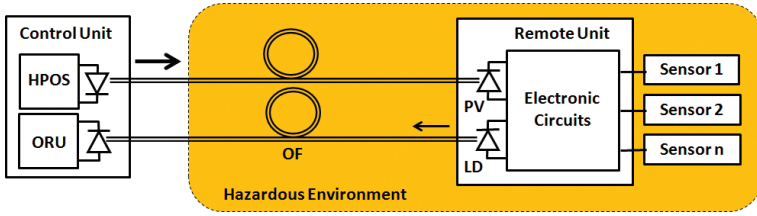

Figure 1. Generic PoF system diagram showing its main elements HPOS, OF, PV, LD, electronic circuit, and sensors.

detects the power transmitted by the HPOS. The electrical energy produced by the photovoltaic converter is used to power up a low-threshold laser (LD), electronic circuits, and sensors of the remote unit. The optical fibers and the remote unit can be installed in a hazardous environment, such as high-voltage substations, oil refineries, mines, oil tanks, water reservoirs, and sea depth.

The biggest challenge for a generic PoF system is to provide to a load the highest possible power, at the greatest possible distance, with the highest reliability. There are limits today to PoF applications and the limits are attributed to technological, physical, and cost aspects of PoF elements.

The amount of power that the PoF system can deliver is determined to a great extent by its components: laser, fiber, and photovoltaic cell. The following parameters can be used to evaluate the delivered electric power (P_{Load}) to an electronic load: the maximum transmitted optical power without causing damages in the optical fiber ($P_{MaxFiber}$); the optical power of the HPOS (P_{HPOS}); the optical power in the PV input (P_{In}); the total loss on the fiber (α_{Fiber}); the total loss of the optical connectors (α_{Conn}); the link distance (L); and the efficiency of the PV (η_{PV}). The power delivered to the extender can be expressed by

$$P_{Load} = P_{In} \cdot \eta_{PV} \tag{1}$$

$$P_{In} = P_{HPOS} \cdot \alpha_{Fiber} \cdot \alpha_{Conn} \tag{2}$$

$$\alpha_{Fiber} = 10^{(-L \cdot \alpha_{FiberdB}/10)} \tag{3}$$

$$\alpha_{Conn} = 10^{(-\alpha_{Conn dB}/10)} \tag{4}$$

where $\alpha_{FiberdB}$ is the fiber attenuation in dB/km and $\alpha_{Conn dB}$ is the total connector loss in dB. Notice that

$$P_{HPOS} \leq P_{MaxFiber} \tag{5}$$

In the following subsections, the main elements of PoF will be described, and **Figure 2** will be used as a reference for further discussion. **Figure 2** shows a qualitative graph of some parameters of the PoF elements, such as the loss of the optical fibers and the responsivity of PV cells. The main spectral bands for HPOS are also shown in **Figure 2**.

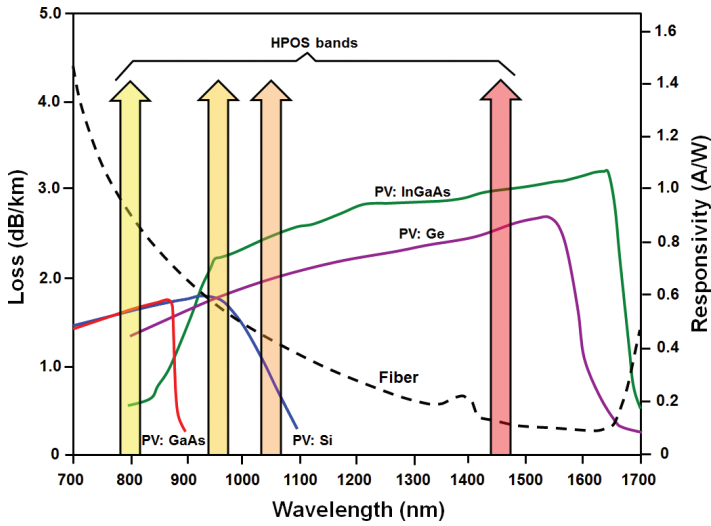

Figure 2. Qualitative graph of some PoF parameters.

2.3. Main elements of PoF

2.3.1. High-power optical source

Figure 2 shows the main spectral bands of HPOS. There are four main bands: 800, 950, 1050, and 1480 nm. The HPOSs for these bands have applications in medicine, pumping, thermal printing, and industrial applications. The power of these HPOSs can reach from 2 to 10 W for TO220 packaging depending on the wavelength band and from 6 to 650 W for laser modules. The output fiber core diameter for these HPOSs ranges from 50 to 600 μm depending on the HPOS output power. These fibers are MM types. For SMF fibers, the output power changes from 0.2 to 1.0 W.

Normally, an SMA (Sub-Miniature A) high-power type with metal ferrule is used in the HPOS output optical fiber. This metal ferrule is used for thermal dissipation in the HPOS connection to the fiber link. The high-power SMA connector utilizes air-gap-ferrule technology that eliminates the materials near the fiber end face that absorbs energy (e.g., epoxy). This absorption can damage the connector end face [56].

HPOS can also transmit information to the remote unit. The information signal is modulated in the continuous optical power generated by the HPOS. In general, this signal transmits commands to be executed in the remote unit, such as requesting the sensor parameters transmission, switching the sensor, and so on.

The most common modulation formats used to modulate the HPOS are on-off keying (OOK), pulse-width modulation (PWM), or frequency modulation. The extinction ratio of this signal can be high (100%) for few milliseconds like burst signals or low (less than 5%) during all the time of optical power sending. The extinction ratio is the ratio of the power used to transmit a

logic level “1,” to the power used to transmit a logic level “0.” **Figure 3** shows an oscilloscope trace (voltage vs. time) of a telecommand signal transmitted over the optical supply power.

The main HPOS parameters required for a PoF project are maximum output power (P_{HPOS}), the operation wavelength (λ_{op}), the output fiber core diameter (D_{core}), the numerical aperture of the fiber (NA), and connector loss $\alpha_{\text{Conn dB}}$.

2.3.2. Optical fiber

The next element in the PoF system after the HPOS is the optical fiber, which is responsible to send the optical power from the HPOS to the PV. The fiber has two main parameters in the PoF system design: its attenuation and its limit of transmitted optical power.

The attenuation in modern optical fiber is basically caused by the intrinsic loss due to Rayleigh backscattering. Silica fibers are glasses that have materials with microscopic variations of density and refractive index. This effect gives rise to energy losses due to the scattered light. The loss due to the Rayleigh backscattering has high dependence with the operation wavelength ($1/\lambda_{\text{op}}^4$). The typical loss in the HPOS bands is 2.8 (800 nm), 1.8 (950 nm), 1.4 (1050 nm), and 0.25 dB (1480 nm).

The loss of optical fiber is not a big problem for the major PoF applications that has dozens of meters of fibers. It can be a problem for distances longer than 1 km. The major problem is regarding the maximum transmitted optical power. Next, the physical mechanism that limits the power in optical fiber will be detailed. After this limit, a degradation of the fiber core and the fiber coating occurs.

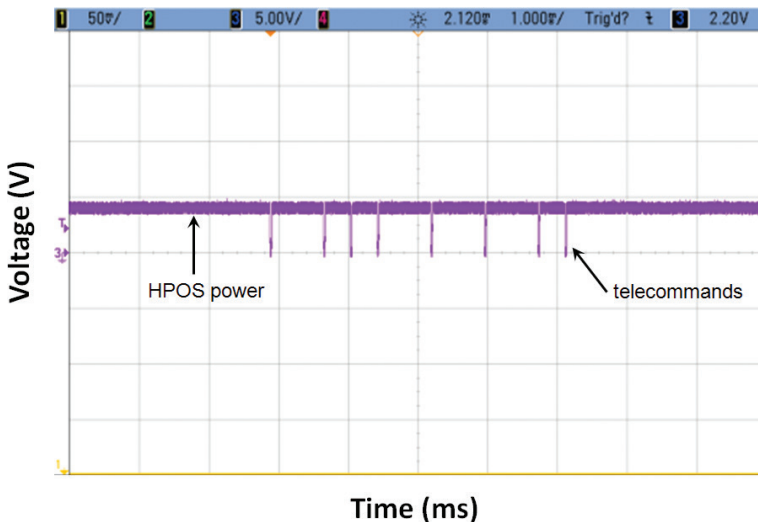

Figure 3. Oscilloscope trace showing a telecommand signal transmitted over the optical supply power.

Optical fibers when subjected to reduced diameter curvatures exhibit further attenuation of the optical signal. This attenuation may be significant when the bending diameter reaches a critical value. The attenuation of the optical signal in the bending zone of the fiber is related to the leakage of the fiber core region signal to the cladding region. The material of the outer-coating layer of the optical fiber absorbs the signal lost to the cladding region. When a high-power optical signal is propagated in the fiber, the energy absorbed by the coating in the zone of curvature is high, generating a local increase in temperature in the coating [56].

The heating of the coating of the optical fiber leads to its degradation, implying a consequent reduction of the useful life of the fiber. This degradation of the optical fiber is related to the reduction of the volume of the coating in the zone of curvature.

The second problem resulting from the propagation of high-power signals is the occurrence of the “fiber-fuse” effect on the optical fibers. This phenomenon was first observed in 1987 in a standard SMF fiber with optical intensity exceeding 5 MW/cm^2 at 1064 nm [57]. The fiber-fuse effect was initiated at a point of the fiber with a high-temperature value, then propagating toward the optical source with a velocity of about 1 m/s and emitting an optical signal in the spectral region of the visible. The propagation of this high-temperature zone is similar to the burning of a wick, which gave rise to the name of the “fiber-fuse” effect. After propagation of the fiber-fuse effect, the optical-fiber core presents a periodic bubble chain (see **Figure 4**) and is permanently destroyed, being unable to guide an optical signal.

Currently, the most accepted general explanation for the fiber-fuse effect relates to the ignition of this effect with the increase of fiber optic absorption at a point with a high-temperature value [56]. In turn, the increase in optical signal absorption is responsible for the catastrophic temperature increase in the fiber core, reaching values higher than the vaporization temperature of the silica. Through the thermal diffusion mechanism, this high-temperature zone is transmitted to neighboring regions and the process evolves toward the optical source. Thus, the “fiber-fuse” effect is related to the increase in fiber optic absorption and the thermal diffusion process.

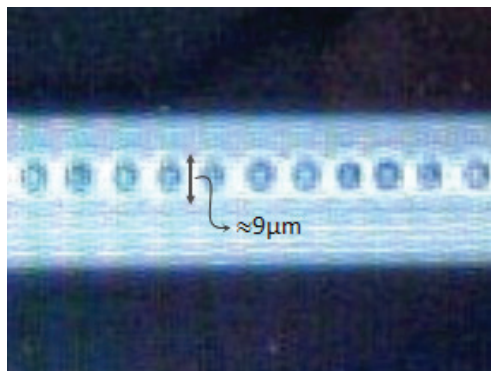

Figure 4. Schematic of a fiber-fuse effect and a photo of an optical fiber core presenting a periodic bubble chain due to fiber-fuse effect.

It should be noted that ignition and propagation of the fiber-fuse effect occurs only if the power of the optical signal in the fiber is maintained above a threshold value. According to [56], this threshold is proportional to the diameter of the fiber modal field (MDF) and dependent on the wavelength of the optical signal. A typical SMF fiber (MDF = 7.8 μm) presents a threshold of 1.5 W at 1467 nm. In other study [58], it was observed that an SMF fiber type 28F (MDF = 7.8 μm) presents a threshold of 1.0 W, and an MM fiber of 62.5- μm core (MDF = 12.0 μm) presents a threshold of 4.0 W at 1060 nm.

In order to increase the optical power in SMF fibers, many efforts have been made to transmit the high power by the cladding of the SMF fiber. In [21, 22], an optically controlled beam steering system using 60 W transmitted in the cladding of the fiber to feed remote antenna units is presented.

The propagation of signals with optical power exceeding the threshold required for ignition and propagation of the fiber-fuse effect is not sufficient to trigger it, and an ignition point characterized by having a high-temperature value is also required. This point of ignition occurs in contaminated and/or degraded connectors or in optical fibers subject to tight bending. As described previously, in optical fibers subjected to curvatures of reduced diameters, an additional attenuation of the optical signal occurs, which in combination with high-power signals generates a considerable localized heating.

Optical connectors can be easily contaminated with dust or organic particles that are common in outdoor environments. This additional attenuation in the connectors, contaminated and/or degraded, may be considerable and when associated with high-power signals also generate localized heating.

PoF is generally used in hazardous environment requiring rugged optical cables for this kind of environment. It is desirable that such cables containing fiber from 100- to 1000- μm core diameter be available on the market, since PoF requires fibers with large core diameter. The development of a rugged PoF optical cable using 100- μm fiber core for long-distance applications is described in [52].

The main OF parameters required for a PoF project are maximum transmitted optical power without causing damages (P_{MaxFiber}), fiber attenuation (α_{FiberdB}) in dB/km at the operation wavelength (λ_{op}), the fiber core diameter (D_{core}), and the numerical aperture of the fiber (NA).

2.3.3. Photovoltaic converter

A photovoltaic power converter is the element where the light will be finally transformed in electricity to supply the control unit and the sensors. PV is one (or more) photodiode that operates in photovoltaic mode. When the supply optical power reaches the PV, electron-hole pairs (carriers) are generated creating a photocurrent. The total current is the photocurrent produced by the supply optical power minus the dark current, which is related to the reverse saturation current. This photocurrent (I_{ph}) is proportional to the incident supply optical power according to Eq. (6)

$$I_{\text{ph}} = P_{\text{In}} \cdot R(\lambda_{\text{op}}) \quad (6)$$

$R(\lambda_{op})$ is the spectral responsivity of the cell, which is dependent on the HPOS operation wavelength (**Figure 2**).

The most important photovoltaic parameter is the conversion efficiency (η). It is defined as the maximum electric power produced by the PV ($P_{elecmax}$) divided by the incident light power under standard light conditions or as defined by Eq. (7):

$$\eta = P_{elecmax} / P_{Pin} = (V_{oc} \cdot I_{sc} \cdot FF) / (P_{Pin}) \quad (7)$$

where V_{oc} is the open-circuit voltage, I_{sc} is the short circuit current, and FF is the fill factor of PV.

Many PV types are actually made of micro-PV arrays [59, 60]. In this way, connecting the micro-PVs in parallel to the output voltage can reach an adequate level. **Figure 5** shows a schematic arrangement of a commercial PV array with four elements compared with 100- μ m-core optical-fiber diameter. This type of fiber is normally used in fiber-packaged PVs.

The fill factor is the parameter that evaluates the junction quality and series resistance of the PV array. The fill factor is the ratio of the maximum electric output power to the product of VOC and ISC.

A comparative study of PV efficiency for the materials Si, GaAs, and Ge is founded in [61]. PV devices made of Si or GaAs proper for PoF uses can be founded in market. Unfortunately, these devices operate in the spectrum region where the fiber does not have the minimum attenuation (**Figure 2**). For operation in 1310 or 1550 nm, the PV arrays can be obtained easily connecting many InGaAs or Ge photodiodes in series or in parallel using an optical splitter. This is a topic for the next section.

The main PV parameters required for a PoF project are the maximum output electric power ($P_{elecmax}$), the maximum optical input power without damaging the PV (P_{Inmax}), the operation spectral band (λ_{op}), the efficiency (η), open-circuit voltage (V_{oc}), and the short-circuit current (I_{sc}).

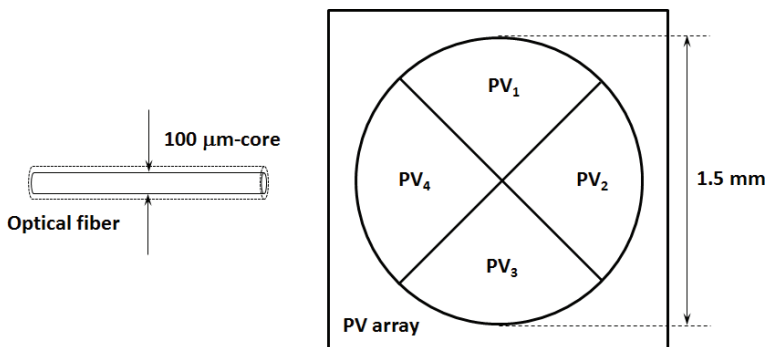

Figure 5. Schematic arrangement of a commercial PV array with four elements compared with 100- μ m-core optical fiber diameter.

2.3.4. Basic remote unit circuits

The electronic circuits of unit control including LD driver and sensors need to work in a specific voltage (V_{cc}), and they consume an electrical current (I_{load}). To provide the required voltage and current, some basic circuits can be designed. The most basic circuits use just one PV and a DC-DC converter to stabilize the voltage, as shown in **Figure 6(a)**. In this case, the PV should be an array type to provide voltage higher than 3 V, although there are many integrated circuits that work below 3 V. If the PV chosen has low-output voltage (lower than 2V), the circuit shown in **Figure 6(b)** can be used. In this circuit, the DC-DC converter was substituted by a step-up converter, which elevates the PV output voltage to the voltage required by the circuit. Other possibility to elevate the voltage is using an optical splitter (with n output ports) connected to the optical fiber and the PVs (or photodetectors) connected in series (**Figure 6(c)**). Typically, splitters with $n = 4-8$ have been used, to provide V_{cc} ranging from 2.4 to 4.8 V. Each splitter output port is connected to one PV. This is an easy solution to use in spectral bands where there is no commercial PV array available, such as in 1310 and 1550 nm. **Figure 6(d)** shows a different version of **Figure 6(c)** circuit. In this case, the association of the PVs is made in parallel in order to increase the current available to the circuit. Certainly, the association of PVs can be made simultaneously in parallel and in series.

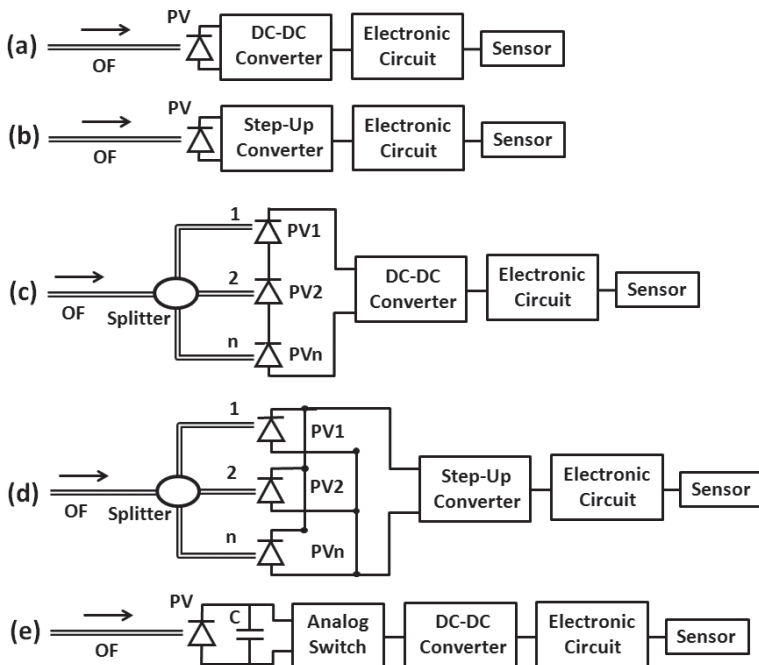

Figure 6. Some types of circuits used in the design of PoF remote units, (a) direct conversion, (b) conversion using a step-up converter, (c) PVs connected in series, (d) PVs connected in parallel, and (e) charging circuit using a capacitor.

Figure 6(e) shows a charging circuit type. This type of circuit is used to supply loads in long-distance PoF links where the available input optical power level in the PV is not enough to provide a necessary electric power. In this circuit, when the capacitor C connected in the PV output is charged in the maximum PV voltage output, an analog switch connects the capacitor to a DC-DC converter that stabilizes its output voltage for the load for a specific time period. This type of circuit should be used only if the sensors do not require measuring their parameters all the time.

2.4. PoF topologies

The connection between the control units and remote units in PoF systems is usually made in the same way of telecommunications links. **Figure 7(a)** shows a typical PoF link using two fibers. However, in some cases the quantity of fibers is a limiting factor in specific application. WDM can be used to multiply the supply optical power transmitted by the HPOS and the sensor signal transmitted by the LD in the remote unit. The WDM device must support the high power of the HPOS. WDM devices for high-power applications can support around 2 W of handling power. The wavelength pairs used in a WDM PoF system as the one shown in **Figure 7(b)** are as follows:

- $\lambda_1 = 808\text{--}830$ (only for MM fibers), 980, and 1480 nm;
- $\lambda_2 = 1310$ and 1550 nm.

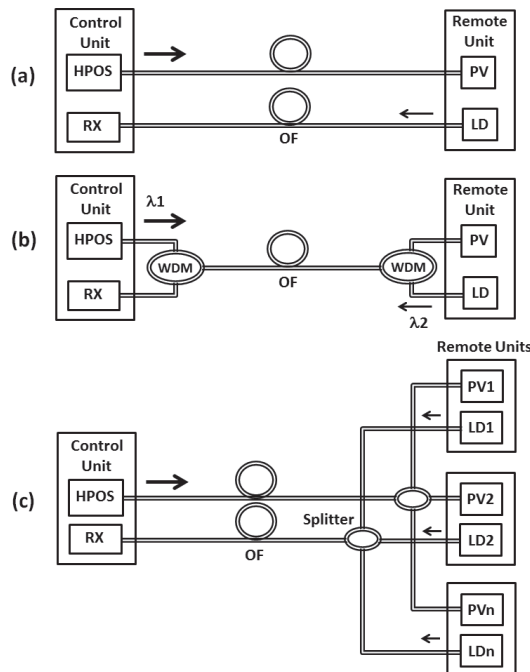

Figure 7. Illustrations of some topologies for PoF systems, (a) two fibers topology, (b) bidirectional WDM topology, and (c) tree topology.

PoF networks have also been reported. A typical tree topology (Figure 7(c)) permits the connection of a single control unit to many remote units. This type of network works in a similar way as a passive optical network used in telecommunications.

2.5. Example of PoF link calculations

Using Eqs. (1)–(5), it is possible to calculate the maximum PoF link for two cases, using SMF and MM fibers. Table 1 shows the parameters used in this calculation.

Figure 8 shows a plot of the delivered power (P_{Load}) to an electronic load as a function of link distance. It can be observed that MM fiber option is better until 2.2 km. After this distance, the SMF option is better.

Parameter/fiber	SMF	MM
HPOS optical power	1.0 W	2.0 W
Wavelength	1480 nm	830 nm
Total connectors attenuation	1.0 dB	1.0 dB
Fiber attenuation	0.25 dB/km	3.0 dB/km
PV efficiency	0.2	0.4
PV material	InGaAs	GaAs

Table 1. Parameters used to calculate the maximum PoF link distance.

In utilities, the major applications of PoF occur in the substations, which the maximum internal distances are less than 0.2 km. For telecommunications, the distances in the major application are longer than 2 km.

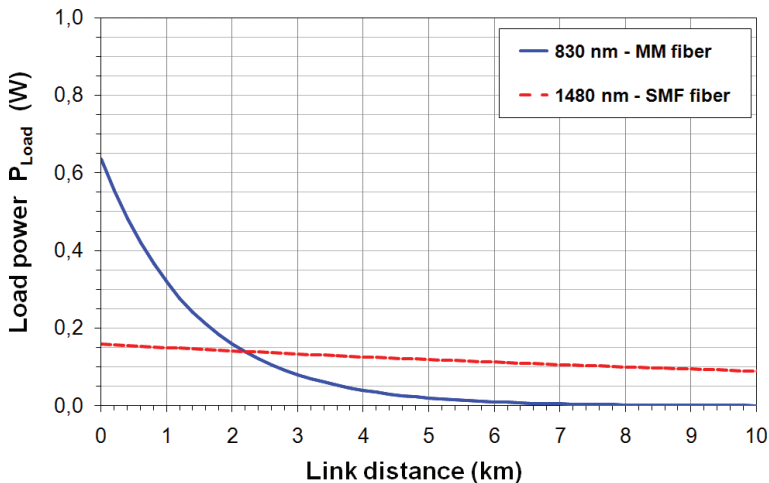

Figure 8. Plot of the delivered power to an electronic load as a function of link distance.

2.6. PoF applications developed at CPqD

This section presents some PoF systems and sensors developed by the author's group for telecommunications and for utilities applications. Most PoF systems for utilities have been tested in field trials.

2.6.1. PoF applications in telecommunications

In telecommunication, we developed a new approach to powering PON extenders using PoF [14]. PON extenders are elements that recover the downstream and upstream signals. These signals are highly attenuated by the splitters and by link length in any PON. However, the use of extenders in PON modifies its passive characteristic since extenders require electrical supply to work. Using PoF to supply, the extenders turns them virtually passives.

Using PoF to eliminate the batteries located at telecom remote sites, the reliability and the security of the system are improved. Furthermore, PoF can reduce the copper cables theft, used to power the extenders in many cases. We demonstrated the performance of a fiber-powered extender using semiconductor optical amplifiers in a 10-gigabit passive optical network system and a gigabit passive optical network system (G-PON) setup using a 1:32 splitter and 50-km reach. The extender was powered from a remote site placed in the access area using a 62.5- μm MM fiber at 830 nm. **Figure 9** shows a schematic of the PON using the fiber-powered extender and the photo of the extender.

2.6.2. PoF applications in utilities

In utilities, we developed applications for monitoring hydrogenerators, power transformers, switchgears, and for transmission lines.

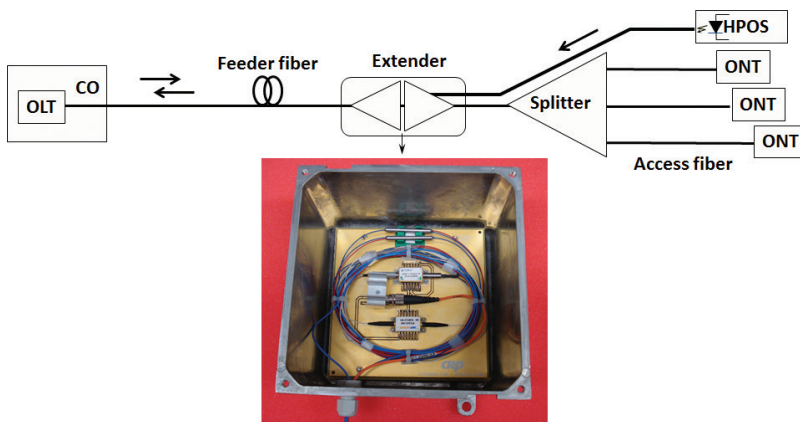

Figure 9. Schematic of a PON using extender powered by a PoF system and the extender photo.

Figure 10 shows the applications for partial discharges monitoring in hydrogenerators [46] and for 500-kV power transformers [62]. Partial discharges on high-voltage equipment insulation are a symptom of fragility of the dielectric capacity. The growing of partial discharges can cause serious consequences for the equipment and the electrical system. Partial discharges generate some physical effects, such as conducted and radiated electromagnetic pulses, light, acoustic noise, localized temperature variation, and chemical reactions. In the developed PoF-monitoring systems, we used a powered antenna to detect the radiated electromagnetic pulses of discharges.

For hydrogenerator monitoring (**Figure 10(a)**), the sensor is composed by one dipole meander antenna, one photovoltaic converter, and one semiconductor laser. Some passive components such as resistors, capacitors, and inductors are omitted in the schematic of sensor circuit to simplification. This system was installed in the Eletrobrás' Coaracy Nunes power plant, which is located in Amapá state, in the north of Brazil.

The sensor for monitoring the high-voltage power transformers (**Figure 10(b)**) is composed by one monopole antenna, one photovoltaic converter, one field-effect transistor (FET) amplifier, and one semiconductor laser. The FET was used in this sensor to increase the sensitivity of the sensor in this particular application. This system was installed in the Cemig's Neves substation, which is located in Minas Gerais state, in the southeast of Brazil.

Figure 10 shows the schematic circuit and sensor photo of antenna powered by fiber for partial discharges monitoring in (a) hydrogenerators and (b) high-voltage power transformers.

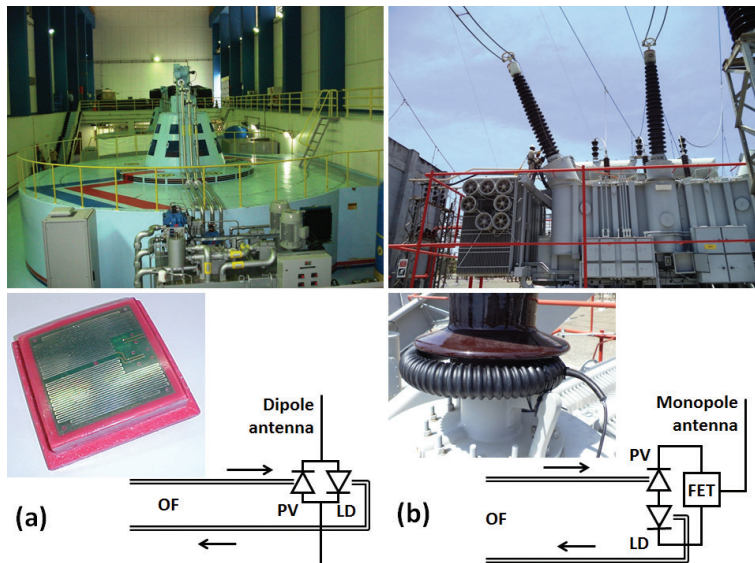

Figure 10. Schematic circuit and sensor photo of antenna powered by fiber for partial discharges monitoring in (a) hydrogenerators and (b) high-voltage power transformers.

Figure 11 shows some applications using more complex electronic circuits with PoF. **Figure 11(a)** shows a 138-kV switchgear-monitoring application using fiber-powered video cameras to inspect the quality contact of the switchgear [53]. In this application, the three phases of 138-kV switchgear were monitored using three sensors. The connection of the sensors to the control unit used the tree topology shown in **Figure 7(c)**. This system was installed in the Cemig's Bonsucesso substation, which is located in Minas Gerais state, in the southeast of Brazil.

Figure 11(b) shows a fiber-powered camera installed in a 138-kV transmission line tower [51]. The camera was used to monitor possible invasions in the security area of transmission line. The circuit of the camera works in a noncontinuous regime (circuit of **Figure 6(e)**) since the power transmission was done using an SMF fiber embedded in an optical ground wire cable. This system was installed in the Cemig's Bonsucesso/Gutierrez transmission line, which is located in Minas Gerais state, in the southeast of Brazil.

Remembering that for electrical utilities, there are key factors to use PoF. Optical fiber is made of nonconductive material. In high-voltage environment, any conductance can

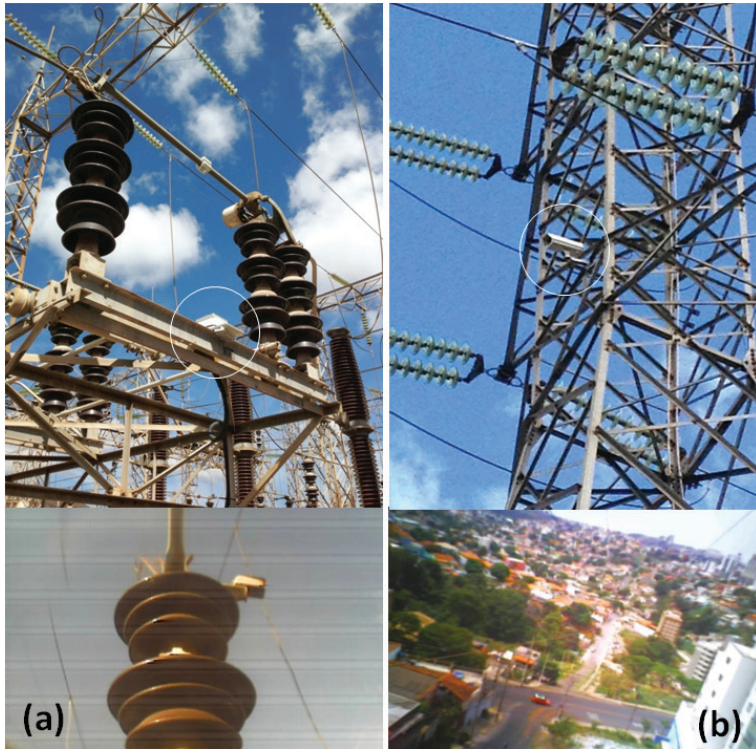

Figure 11. PoF applications with fiber-powered video cameras, (a) 138-kV switchgear sensor shown in the circle (above) and a sensor image (below) and (b) 138-kV transmission line sensor shown in the circle (above) and a sensor image (below).

create current leaks. Optical fiber is immune to electromagnetic interferences. The electrical world environment is polluted of electromagnetic interferences; therefore, optical fiber can transmit signals without quality degradation. The optical fiber eliminates the need to run conductive copper wire into a GPR zone. GPR arises when lightning strikes occur in substations and can cause severe interference problems in electronic equipment and systems. PoF sensors have a complete galvanic isolation to the ground potential, then they are practically immune to the GPR effects and finally, as we show, there are many low-cost/low-power/high-efficiency electronic sensors available for transmission lines and substations monitoring that can be supplied by PoF increasing the monitoring capacity for utilities companies.

3. Conclusion and future perspectives

In conclusion, this chapter described a revision of PoF, its technical principles, main elements, technologies, and the applications focusing in telecom and in utilities, developed by the author's group.

The applications for PoF have evolved over the last years mainly in terms of power availability for the load in the remote units. Many publications describe incredible dozen watts power transmitted in the SMF fiber cladding. This evolution allows applications to become more complex using PoF, such as video cameras powering, antennas powering, or PoF networks.

The increase of supplier's options for PoF devices and fibers has also been occurring and it can reduce the cost of this interesting optical fiber technique.

Acknowledgements

The author wishes to thank his CPqD colleagues Claudio Florida, Danilo C. Dini, Rivaél S. Penze, Fabio R. Bassan, and João P. V. Fracarolli. Many PoF projects cited in this work were funded by ANEEL (Brazilian Electricity Regulatory Agency). CNPq (National Counsel of Technological and Scientific Development) sponsors the author under scholarship DT.

Author details

Joao Batista Rosolem

Address all correspondence to: rosolem@cpqd.com.br

CPqD—Research and Development Center in Telecommunications, Campinas, SP, Brazil

References

- [1] DeLoach BC, Miller RC, Kaufman S. Sound alerter powered over an optical fiber. *Bell System Technical Journal*. 1978;**57**:3309–3316. DOI: 10.1002/j.1538-7305.1978.tb02205.
- [2] Miller RC, Lawry RB. Optically powered speech communication over a fiber lightguide. *Bell System Technical Journal* 1979;**58**:1735–1741. DOI: 10.1002/j.1538-7305.1979.tb02280.x
- [3] Miller RC, DeLoach BC, Stakelon TS, Lawry RB. Wideband, bidirectional lightguide communication with an optically powered audio channel. *Bell System Technical Journal* 1982;**61**:1538–7305. DOI: 10.1002/j.1538-7305.1982.tb04349.x
- [4] Banwell TC, Estes RC, Reith LA, Shumate Jr PW, Vogel EM. Powering the fiber loop optically—a cost analysis. *Journal of Lightwave Technology*. 1993;**11**:481–494. DOI: 10.1109/50.219583
- [5] Miyakawa H, Hyodo R, Tanaka Y, Kurokawa T. Photovoltaic cell characteristics for high-intensity laser light in fiber optic power transmission systems. In: *Proceedings of Conference Record of the Twenty-Ninth IEEE Photovoltaic Specialists Conference*; 19–24 May 2002; New Orleans, USA; **29**:1653–1655. DOI: 10.1109/PVSC.2002.1190934
- [6] Miyakawa H, Herawaty E, Yoshimoto M, Tanaka Y, Kurokawa T. Power-over-optical local area network systems. In: *Proceedings of 3rd World Conference on Photovoltaic Energy Conversion*; 11–18 May 2003; Osaka, Japan; **3**:2466–2469.
- [7] Miyakawa H, Tanaka Y, Kurokawa T. Design approaches to power-over-optical local-area-network systems. *Applied Optics* 2004;**43**:1379–1389. DOI: 10.1364/AO.43.001379
- [8] Werthen JG, Cohen M. Photonic power: delivering power over fiber for optical networks. In: *Proceedings of 2006 International Conference on Photonics in Switching*; 16–18 October 2006; Heraklion, Crete; pp. 1–3. DOI: 10.1109/PS.2006.4350205
- [9] Werthen JG. Powering next generation networks by laser light over fiber. In: *Proceedings of 2008 Conference on Optical Fiber Communication/National Fiber Optic Engineers (OFC/NFOEC 2008)*; 24–28 February 2008; San Diego; USA, pp. 1–3. DOI: 10.1109/OFC.2008.4528749
- [10] Wake D, Nkansah A, Gomes N. Optical powering of remote units for radio over fiber links. In: *Proceedings of 2007 International Topical Meeting on Microwave Photonics*; 3–5 Oct. 2007; VIC, Canada; pp. 29–32. DOI: 10.1109/MWP.2007.4378127
- [11] Wake D, Nkansah A, Gomes NJ, Lethien C, Sion C, Vilcot J P. Optically powered remote units for radio-over-fiber systems. *Journal of Lightwave Technology*. 2008;**26**:2484–2491. DOI: 10.1109/JLT.2008.927171
- [12] Sato J, Matsuura M. Radio-over-fiber transmission with optical power supply using a double-clad fiber. In: *Proceedings of 18th OptoElectronics and Communications*

- Conference held Jointly with 2013 International Conference on Photonics in Switching (OECC/PS); 30 June–4 July 2013; Kyoto, Japan; pp. 1–2.
- [13] Matsuura M, Sato J. Power-over-fiber using double-clad fibers for radio-over-fiber systems. In: Proceedings of 19th European Conference on Networks and Optical Communications (NOC); 4–6 June 2014; Milano, Italy; pp. 126–131. DOI: 10.1109/NOC.2014.6996840
- [14] Penze RS, Rosolem JB, Duarte UR, Paiva GER, Filho RB. Fiber powered extender for XG-PON/G-PON applications. *IEEE/OSA Journal of Optical Communications and Networking*. 2014;6:250-258. DOI: 10.1364/JOCN.6.0002
- [15] Ikeda K. Lightning protection of microwave radio equipment using radio on fiber and power over fiber experimental demonstration of communication quality. In: Proceedings of Microwave Photonics (MWP) and the 9th Asia-Pacific Microwave Photonics Conference (APMP) International Topical Meeting on; 20–23 October 2014; Sendai, Japan; pp. 185–188. DOI: 10.1109/MWP.2014.6994526
- [16] Yan J, Wang J, Lu Y, Jiang J, Wan H. Novel wireless sensor system based on power-over-fiber technique. In: Proceedings of 14th International Conference on Optical Communications and Networks (ICOON); 3–5 July 2015; Nanjing, China; pp. 1–3. DOI: 10.1109/ICOON.2015.7203710
- [17] Matsuura M, Sato J. Bidirectional radio-over-fiber systems using double-clad fibers for optically powered remote antenna units. *IEEE Photonics Journal*. 2015; 7:1–9. DOI: 10.1109/JPHOT.2014.2381669
- [18] Sato J, Furugori H, Matsuura M. 40-watt power-over-fiber using a double-clad fiber for optically powered radio-over-fiber systems. In: Proceedings of Optical Fiber Communications Conference and Exhibition (OFC); 22–26 March 2015; Los Angeles, USA; pp. 1–3. DOI: 10.1364/OFC.2015.W3F.6
- [19] Lee Y, Suto K, Nishiyama H, Kato N, Ujikawa H, Suzuki K. I. A novel network design and operation for reducing transmission power in cloud radio access network with power over fiber. In: Proceedings of IEEE/CIC International Conference on Communications in China (ICCC); 2–4 November; Shenzhen, China; pp. 1–5. DOI: 10.1109/ICCCChina.2015.7448616
- [20] Suto K, Miyanabe K, Nishiyama H, Kato N, Ujikawa H, Suzuki KI. QoE-guaranteed and power-efficient network operation for cloud radio access network with power over fiber. *IEEE Transactions on Computational Social Systems*;2:127–136. DOI: 10.1109/TCSS.2016.2518208
- [21] Minamoto Y, Matsuura M. Optically controlled beam steering system with 60-W power-over-fiber feed for remote antenna units. In: Proceedings of Optical Fiber Communications Conference and Exhibition (OFC), Anaheim, USA; 20–24 March 2016; pp. 1–3.
- [22] Matsuura M, Minamoto Y, Optically powered and controlled beam steering system for radio-over-fiber networks. *Journal of Lightwave Technology*. 2017; 35:979-988. DOI: 10.1109/JLT.2016.2631251

- [23] Yoneyama A, Minamoto Y, Matsuura M. Power-over-fiber transmission using 1.3- μm dual-channel radio-over-fiber signals in a double-clad fiber. In: Proceedings of 21st OptoElectronics and Communications Conference (OECC) held jointly with 2016 International Conference on Photonics in Switching (PS); 3–7 July 2016; Niigata, Japan; pp. 1–3.
- [24] Umezawa T, et al. 11-Gbps 16-QAM OFDM radio over fiber demonstration using 100 GHz high-efficiency photoreceiver based on photonic power supply. In: Proceedings of 21st OptoElectronics and Communications Conference (OECC) held jointly with 2016 International Conference on Photonics in Switching (PS); 3–7 July 2016; Niigata, Japan; pp. 1–33.
- [25] Umezawa T, et al. Multi-core based 94-GHz radio and power over fiber transmission using 100-GHz analog photoreceiver. In: Proceedings of 42nd European Conference on Optical Communication (ECOC 2016), 18–22 Sept. 2016; Dusseldorf, Germany; pp. 1–3. DOI: 10.1109/JSTQE.2016.2611638
- [26] Umezawa T, et al. 100-GHz fiber-fed optical-to-radio converter for radio- and power-over-fiber transmission. IEEE Journal of Selected Topics in Quantum Electronics. 2017; 23:1–8. DOI: 10.1109/JSTQE.2016.2611638
- [27] Caspers F, Neumann EG. Optical power supply for measuring or communication devices at high-voltage levels. IEEE Transactions on Instrumentation and Measurement. 1980; 29:73–74. DOI: 10.1109/TIM.1980.4314866
- [28] Ohte A, Akiyama K, Ohno I. Optically-powered transducer with optical-fiber data link. In: Proceedings of SPIE 0478, Fiber Optic and Laser Sensors II; 17 September 1984; Arlington, USA. DOI: 10.1117/12.942655
- [29] Trisno YS, Wobschall D. Optimization of an optically pulsed photocell array as a sensor power source. IEEE Transactions on Instrumentation and Measurement. 1988; 37:142–144. DOI: 10.1109/19.2683
- [30] Bjork P, Lenz J, Fujiwara K. Optically powered sensors. In: Proceedings of Optical Fiber Sensors, OSA Technical Digest Series; Mar 1988; New Orleans, USA. DOI: 10.1109/19.2683
- [31] Lenz J, Bjork P, Optically powered sensors: a systems approach to fiber optic sensors. In: Proceedings of SPIE 0961, Industrial Optical Sensing, 29 November 1988; Dearborn, USA. DOI: 10.1117/12.947855
- [32] Kirkham H, Johnston AR. Optically powered data link for power system applications. IEEE Transactions on Power Delivery. 1989; 4:1997–2004. DOI: 10.1109/61.35623
- [33] Yamagata Y, Kumagai T, Sai Y, Uchida Y, Imai K. A sensor powered by pulsed light (for gas density of GIS). In: Proceedings of Solid-State Sensors and Actuators, International Conference on Transducers '91, 24–27 June 1991; San Francisco, USA; pp. 824–827. DOI: 10.1109/SENSOR.1991.149011
- [34] Sai Y. Optimization of optically powered sensors. In: Proceedings of International Conference on Industrial Electronics, Control and Instrumentation, IECON '91; 28 October–1 November 1991, Kobe, Japan, pp. 2439–2443. DOI: 10.1109/IECON.1991.238962

- [35] Nieuwkoop E, Kapsenberg T, Steenvoorden GK, Bruinsma AJ. Optically powered sensor system using conventional electrical sensors. In: Proceedings of SPIE 1511, Fiber Optic Sensors: Engineering and Applications; 1 August 1991; The Hague, Netherlands. DOI:10.1117/12.45999
- [36] Spillman Jr WB, Crowne DH. Optically powered and interrogated rotary position sensor for aircraft engine control applications. *Optics Lasers Engineering*. 1992; **16**:105–118. DOI:10.1016/0143-8166(92)90003-P
- [37] Tardy A, Derossis A, Dupraz JP. A Current sensor remotely powered and monitored through an optical fiber link. *Optical Fiber Technology*; 1995; **1**:181–185. DOI: 10.1006/ofte.1995.1010
- [38] Pember SJ, France CM, Jones BE. A multiplexed network of optically powered, addressed and interrogated hybrid resonant sensors. *Sensors and Actuators A: Physical*; 1995; **47**:474–477. DOI:10.1006/ofte.1995.1010
- [39] Dubaniewicz Jr TH, Chilton JE. Fiber optic powered remote gas monitor. In: Proceedings of SPIE 2622, Optical Engineering Midwest '95; 18 August 1995; Chicago, USA. DOI:10.1117/12.216819
- [40] Werthen JG, Andersson G, Weiss ST, Bjorklund HO. Current measurements using optical power. In: Proceedings of Transmission and Distribution Conference and Exposition; 15–20 Sept. 1998; Los Angeles, USA, pp. 213–218. DOI: 10.1109/TDC.1996.545937
- [41] Wang L, Wang Y, Shi J, Zheng L. Optically powered hydrostatic tank gauging system with optical fiber link. In: Proceedings of SPIE 3555, Optical and Fiber Optic Sensor Systems; 13 August 1998; Beijing, China; DOI:10.1117/12.318165
- [42] Zhijing Y. Optically powered oil tank multichannel detection system with optical fiber link. In: Proceedings of SPIE 3555, Optical and Fiber Optic Sensor Systems; 13 August 1998; Beijing, China. DOI:10.1117/12.318152
- [43] Turán J, Ovseník L, Turán Jr J. Optically powered fiber optic sensors. *Acta Electrotechnica et Informatica*. 2005; **5**:1–7.
- [44] Bottger G, et al. An optically powered video camera link. *IEEE Photonics Technology Letters*; 2008; **20**:39–41. DOI: 10.1109/LPT.2007.912695
- [45] Röger M, Böttger G, Dreschmann M, Klamouris C, Huebner M, Bett AW, Becker J, Freude W, Leuthold J. Optically powered fiber networks. *Optics Express*. 2008; **16**:21821–21834. DOI:10.1364/OE.16.021821
- [46] Rosolem JB, Florida C, Sanz JPM. Field and laboratory demonstration of a fiber-optic/RF partial discharges monitoring system for hydrogenerators applications. *IEEE Transactions on Energy Conversion*. 2010; **25**:884–890. DOI: 10.1109/TEC.2010.2044507
- [47] de Nazaré FVB, Werneck MM. Temperature and current monitoring system for transmission lines using power-over-fiber technology. In: Proceedings of IEEE Instrumentation & Measurement Technology Conference; 3–6 May 2010; Austin, USA; pp. 779–784. DOI: 10.1109/IMTC.2010.5488198

- [48] Audo F, Guegan M, Quintard V, Perennou A, Bihan JL, et al. Quasi-all-optical network extension for submarine cabled observatories. *Optical Engineering*. 2011; 50:1-8. DOI: 10.1117/1.3560542
- [49] Lau FK, Stewart B, McStay D. An optically remote powered subsea video monitoring system. In: *Proceedings of SPIE 8372, Ocean Sensing and Monitoring IV*, 837209; 12 June 2012; Baltimore, USA. DOI:10.1117/12.920834
- [50] Tanaka Y, Kurokawa T. A fiber sensor network using fiber optic power supply. In: *Proceedings of SPIE 8421, OFS2012 22nd International Conference on Optical Fiber Sensors*; 84211M; 14 October 2012; Beijing, China. DOI:10.1117/12.981524
- [51] Rosolem JB, Bassan FR, Pereira FR, Penze RS, Leonardi AA, et al. Fiber powered sensing system for a long reach single mode fiber link and non-continuous applications. In: *Proceedings of SPIE 9157, 23rd International Conference on Optical Fibre Sensors*, 9157AE; 02 June 2014; Santander, Spain. DOI:10.1117/12.2058672
- [52] Silva JCV, Souza ELAS, Garcia V, Rosolem JB, Florida C., Sanches MAB. Design of a multimode fiber optic cable to transmit optical energy for long reach in PoF systems. In: *Proceedings of IWCS International Cable, Connectivity Symposium*, 9–12 November 2014, Rhode Island, USA.
- [53] Rosolem JB. Quantitative and qualitative monitoring system for switchgear with full electrical isolation using fiber-optic technology. *IEEE Transactions on Power Delivery*. 2015; **30**:449–1457 DOI: 10.1109/TPWRD.2014.2377122
- [54] Rosolem JB, Bassan FR, Penze RS, Leonardi AA, Fracarolli JPV, Florida C. Optical sensing in high voltage transmission lines using power over fiber and free space optics. *Optical Fiber Technology*. 2015; **26**:180–183. DOI: 10.1016/j.yofte.2015.09.003
- [55] Zhang X, et al. A gate drive with power over fiber-based isolated power supply and comprehensive protection functions for 15-kV SiC MOSFET. *IEEE Journal of Emerging and Selected Topics in Power Electronics*. 2016; **4**:946–955. DOI: 10.1109/JESTPE.2016.2586107
- [56] Seo K, Nishimura N, Shiino M, Yuguchi R, Sasaki H. Evaluation of high-power endurance in optical fiber links. *Furukawa Review*. 2003; **24**:17–22.
- [57] Kashyap R, Blow KJ. Observation of catastrophic self-propelled self-focusing in optical fibers. *Electronics Letters*. 1988; **24**:47–49. DOI: 10.1049/el:19880032
- [58] Davis DD, Mettler SC, DiGiovanni DJ. Experimental data on the fiber fuse”, In: *Proceedings of SPIE 2714, 27th Annual Boulder Damage Symposium: Laser-Induced Damage in Optical Materials*; 1995; Boulder, USA; pp. 202–210. DOI:10.1117/12.240382
- [59] Andreev V., et al. High current density GaAs and GaSb photovoltaic cells for laser power beaming. In: *Proceedings of 3rd World Conference on Photovoltaic Energy Conversion*; 11–18 May 2003; Osaka, Japan; pp. 761–764.
- [60] Sohr S, Rieske R, Nieweglowski K, Wolter KJ. Laser power converters for optical power supply. In: *Proceedings of 34th International Spring Seminar on Electronics Technology (ISSE)*; 11–15 May 2011; Trtatanska Lomnica, Slovakia. DOI: 10.1109/ISSE.2011.6053563

- [61] Allwood G, Wild G, Hinckley S. Power over fibre: material properties of homojunction photovoltaic micro-cells. In: Proceedings of Sixth IEEE International Symposium on Electronic Design, Test and Application; 17–19 Jan. 2011; Queenstown, New Zealand, pp. 78–82. DOI: 10.1109/DELTA.2011.66
- [62] Rosolem JB, et al. A fiber optic powered sensor designed for partial discharges monitoring on high voltage bushings. In: Proceedings of SBMO/IEEE MTT-S International Microwave and Optoelectronics Conference (IMOC); 3–6 Nov. 2015; Porto de Galinhas, Brazil, pp. 1–5. DOI: 10.1109/IMOC.2015.7369072