

---

# Algal Biorefinery for Biodiesel Production

---

Didem Özçimen, M. Ömer Gülyurt and Benan İnan

Additional information is available at the end of the chapter

<http://dx.doi.org/10.5772/52679>

---

## 1. Introduction

In recent years, the rapid depletion of fossil fuels, increase in energy demand, global warming, increase in price of fossil fuels depends on economic and political behaviors increased orientation to alternative energy sources. In this context, biodiesel that is one of the renewable alternative energy sources draws attention because of its useful features such as easily biodegradable and environmentally friendly. However, biodiesel production from oil crops does not meet the required demand of vehicle fuel, and recently it is not economic and feasible. It needs to be improved to produce more economically to be able to compete with diesel in the market. Vegetable oils and crops which biodiesel produced from are a kind of human food sources and the shortage on food source cause to go up prices and make the biodiesel high-priced. To meet the requirements, the interest on algae is increased day by day since this technology has potential to meet global demand [1]. Microalgae have higher productivity per area and no need for farm field to grow as opposed to oil crops and animal fat. Microalgae use sunlight to reduce CO<sub>2</sub> to biofuels, foods, fertilizers, and valuable products. Furthermore, microalgae can be used to get different types of biofuels. Using microalgae as fuel source is not a novel idea but recently the prices of diesel and global warming hit this solution to the top [2].

Microalgae have lots of advantages for biodiesel production over other raw materials such as crops, waste cooking oils, and so on. Microalgae have short doubling time which is around 12-24 h since they have a simple structure and capable to high photosynthetic efficiency and they contain much more amount of oil than other oil crops that can be used as oil source for biodiesel production. Compared with the oil yields from various oil crops such as corn (172 L/ha), soybean (446 L/ha), canola (1190 L/ha), jatropha (1892 L/ha), coconut (2689 L/ha) and oil palm (5959 L/ha), oil yield from microalgae is very high as 136900 L/ha and 58700 L/ha for 70% oil in biomass and 30% oil in biomass, respectively [2-4].

The other significant feature is that algae can grow everywhere and every season in a year since there are thousands of algae species that have different adaptations and different properties. They can grow in saltwater, freshwater, lakes, deserts, marginal lands, etc. In addition to biodiesel production, algae can be also used as feedstock to produce different valuable products such as fertilizer, energy, nutraceuticals, protein, animal feed etc. The other significant property is that microalgae can remove some heavy metals, phosphorous, and nitrogen from water during its growth. Algae also clean up the water. Moreover, microalgae sequester lots of carbon by photosynthesis. Utilization of carbon dioxide by algae is significantly lowering the risk for greenhouse gas effects. Lastly, usage of microalgae for biodiesel almost cancels out the carbon dioxide and sulfur release to atmosphere [5]. These reasons mentioned above are enough to believe that microalgae can take the place of fossil fuels completely.

There are many of microalgae studies for biodiesel production. Because the most of the scientists believe that microalgae will take the place of the petroleum diesel, however, algal biodiesel production is not feasible yet since there is no much commercial or large scale production of microalgae for biodiesel. That is why most of the works are focused on decreasing the cost of biodiesel production or make it competitive versus petroleum diesel. Surely, until these improvements are achieved, algal biodiesel can not be an accurate alternative. The current problems making biodiesel expensive can be improved with some innovations. The first of all is about the algae strain which is also first step of algal biodiesel production. The algae strain should be better than recent ones. There are natural many kinds of algae strains and isolation of new natural algae strain may help procedure to be cost effective. The algae strain has to have high lipid productivity and adaptability to new environments. These features let it produce more and obtain more oil content [6, 7]. As an example, if the flue gas is used as carbon dioxide source, microalgae have to be adapted for this situation so that it can tolerate the high concentration of  $\text{SO}_x$ ,  $\text{NO}_x$ , and other gases [8]. That will reduce the cost and increase the biomass growth rate. The other important innovation should focus on cultivation of algae. The large-scale production is one of the most cost-intense parts. The innovative thinking should show a tendency to lower the cost of operation and capital for cultivation systems. As it is explained below, open ponds are the cheapest way but the efficiency of them has to be worked on. Moreover, the closed photobioreactors (PBR) are also being improved for a cheaper way to control and lighten the system. Furthermore, microalgae can be fixed in a cultivation system with an immobilization technique to get higher biomass. The last way to lower the cost is to produce sub-products from microalgae beyond biodiesel. There are lots of high value products and sub-products produced from microalgae such as biogas [9, 10], biobutanol, acetone [11], Omega 3 oil [12], eicosapentaenoic acid [13], livestock feed [14], pharmaceuticals and cosmetics [15, 16]. Especially sub-products can be preferred for economic support of main process.

For example, recovery of methane from microalgae pulp after biodiesel production develops renewability of conversion of microalgae biomass to biodiesel process as much as it makes the cost of process and environmental effects less. The microalgae pulps after oil removed contain significant amounts of protein and carbohydrate that can convert to biogas by anaerobic fermentation. Conversion of algal waste to biogas by anaerobic fermentation will play a dual role for renewable energy production and also sustainable development of microalgal biodiesel industry [17, 18].

Algae can be also used in bioethanol production. Algae are more uniform and continuous than terrestrial plant, due to lack of functional parts such as root and leaf composition. Their cell walls made of polysaccharides that can hydrolyze to the sugar. For this reason, microalgae can be used as carbon source in fermentation process. Ethanol produced by fermentation can be purified for using as a fuel, CO<sub>2</sub> as a nutrient may also be recycled to algae culture to grow microalgae [19, 20].

In this chapter, algae production methods that cover the algae strain and location selection, algae cultivation, harvesting, oil extraction, and algal biodiesel production processes are presented in detail with alternatives. New progresses in this area are also explained.

## 2. Algae strains and properties

Algae are simple organisms including chlorophyll. They can be found in seas, soils and lakes wherever they can use the light for their photosynthesis. There are two types of main algae groups. The first group is macro algae, which includes green, brown and red algae. The second group is microalgae as phytoplankton in the coasts, lakes and oceans, which includes diatoms, dinoflagellates, green and brownish flagellate, and blue-green algae [21].

The classification of algae can be done in many ways since there is a millions of kind. Also there is no standard on classification so you can see different types of classification. The taxonomic group of algae can be given as follow: *Archaeplastida*, *Chlorophyta*(green algae), *Rhodophyta*(red algae), *Glaucophyta*, *Chlorarachniophytes*, *Euglenids*, *Heterokonts*, *Bacillariophyceae*(diatoms), *Axodine*, *Bolidomonas*, *Eustigmatophyceae*, *Phaeophyceae*(brown algae), *Chryso-phyceae*(golden algae), *Raphidophyceae*, *Synurophyceae*, *Xanthophyceae*(yellow-green algae), *Cryptophyta*, *Dinoflagellates*, *Haptophyta*[22].

Algae are the most common wide photosynthetic bacteria ecologically. To grow algae some parameters such as amount and quality of ingredients, light, pH, turbulence, salinity, and temperature become prominent. Macro (nitrate, phosphate, silicate) and micro (some metals, B1, B12 and biotin vitamins) elements are required in the growth of algae. Light intensity has also an important role, the light demand changes up to microalgae density and type of microalgae. The other parameter pH is mostly between 7 and 9 for most of algae strains and mostly the optimum range is 8. 2-8. 7. The last parameter salinity should be between 20-24 ppt. Moreover, nitrogen also affects the growth of some algae strains as such as green algae [22-25].

### 2.1. Macroalgae

Macroalgae are adapted to life in ocean and it is a plant mostly seen on the costal strips. There are plenty of macro algae types. Algae can be classified as brown, red, and green based on type of pigments. Recently, several brown algae types have been used in the industry and energy production as an alternative source to fossil fuels, and green algae is also studied to produce biodiesel [26].

Brown algae have xanthophyll pigments and fucoxanthin, which results the colour of brown algae. These substances mask the other pigments [27]. Polysaccharides and higher alcohols are nutrition reserves of brown algae but the main carbohydrate reserve is laminarin. The cell walls of brown algae are made of cellulose and alginic acid. Brown algae have a lot of features such as: Cytotoxic and antitumor activity, Antifungal activity, Anti-inflammatory activity, Antiviral activity, Protection against herbivorous animals (fish, sea urchins), Antioxidant activity [21, 28, 29]. Composition of brown algae can vary according to species, their location, salinity and season. According to analysis, brown algae contain about 85% high moisture and 25 % high sodium carbonate [26].

Green algae contain chlorophyll a and b. Presence of these pigments makes green color of the green algae. There are a few reports about second metabolites of green algae. [21]. Moisture content of green algae is higher than brown algae but they have similar sodium carbonate content. Green algae species can access higher sugar levels and this makes them useful energy sources. They also have high cellulose content [26]. Green algae have a lot of features such as: Anti-inflammatory substances, Cytotoxic and immunosuppressive activities, Antibacterial activity, Antiviral activity, Antifungal activity [30].

Red Algae have phycoerythrin and phycocyanin pigments that make red color of these algae. These pigments mask the other pigments. The cell walls of red algae made of cellulose, agar and carrageenan [27]. There are approximately 8000 red algae species. In comparison of the other algae species, red algae are considered as the most important active metabolite resource. They have a lot of features such as: Cytotoxic activities, Antiviral activity, Anti-inflammatory activity, Antimicrobial activity, Free radical scavenger activity [21, 31].

## 2.2. Microalgae

There are at least 30000 microalgae species in the world. Microalgae are mostly defined as unicellular photosynthetic cells but some complex associations create larger colonies. This is a heterogenic group, which contains prokaryotic organisms similar to bacteria and eukaryotic cells [26, 32]. Microalgae production is concentrated on particular species, which have special tolerance for extreme conditions in their growth. This situation enables the production in open ponds and canals. In future, microalgae production will focus on more advanced species for the demand of energy and pure monocultures which have specific capabilities like production of carbohydrate, lipid or hydrogen will be cultivated [33]. According to use of algae, biomass of microalgae has variable chemical composition. They can be rich or balanced composition of protein, lipid and sugar. Microalgae selection should be made according to desired biofuels. Microalgae have important lipid content even in the extreme conditions they reach higher lipid content [26].

Green algae or diatoms are the most used microalgae species for production of alternative energy derives. Just a handful of these species has commercial importance. This group contains *Chlorella*, *Spirulina*, *Dunaliella* and *Haematococcus*. Only *Dunaliella* is a dominant sea species. These are usually cultivated for extraction of high value component like pigments or proteins [26].

Blue-green algae (cyanobacteria) have a lot of common structural features with bacteria. They are classified as algae because they contain chlorophyll and other components. They have also nitrogenic components because all of the prokaryote species convert atmospheric nitrogen to ammonium [21, 34]. Morphologically blue green algae can have filamentous, conical or unicellular shape. They have a lot of features such as: anticancer and cytotoxic activities, antibacterial activity, antifungal activity, immunosuppressive activity [21, 35, 36].

*Pyrrhophyta (Dinoflagellates)* are unicellular organisms, which are classified as primitive algae. Large amount concentrations of these organisms exist in ocean surface and they cause fish deaths. Also because of their pigments, dinoflagellates give the water brown to red coloration in the sea [34, 37]. Particular dinoflagellate species produce toxin in case of consumed by species such as shellfish. Consumption of contaminated shellfish by humans can cause a lot of health problems including death [21].

*Bacillariophyceae (Diatoms)* are the most versatile and frequent family. They are more feasible for large-scale productions due to short doubling time and easy to grow. Unlike *Dinoflagellates* they create less second metabolites [38].

Microalgae are investigated as biodiesel feedstock because of their high photosynthetic efficiency, their ability to produce lipids. Macroalgae usually don't contain lipids too much and they are taken into consideration for the natural sugars and other carbohydrates that they contain. These contents can be fermented to produce alcohol-based fuels or biogas.

### 2.3. Lipid content of microalgae species

As the structure of many microalgae species can accumulate significant amounts of lipid and provide high oil yield. Their average lipid contents can be reached to 77% of dry biomass under some certain conditions [39]. Table 1 shows lipid content of some microalgae species.

Microalgae	Oil content (dry weight %)
<i>Botryococcus braunii</i>	25-75
<i>Chlorella protothecoides</i>	14-57
<i>Cryptocodinium cohnii</i>	20-51
<i>Dunaliella tertiolecta</i>	16-71
<i>Nannochloris sp.</i>	20-56
<i>Neochloris oleoabundans</i>	29-65
<i>Phaeodactylum tricornutum</i>	18-57
<i>Schizochytrium sp.</i>	50-77
<i>Skeletonema coastatum</i>	13-51

**Table 1.** Lipid content of some microalgae species [15, 39, 40-45].

Also high productivity is very important beside high oil content. As shown in table 1, microalgal lipid content can reach 77% by weight of dry biomass but it is observed that there can be low productivity of *Botryococcusbraunii*, however, *Chlorella* appears to be a good choice in biodiesel production, since it has high productivity though lower oil content [39].

Lipid content can be affected by several parameters such as nutrition, environment, cultivation phases and conditions growth can affect fatty acid composition [32], Fatty acid composition is important in microalgae selection because it has a significant effect on biodiesel properties. For example, if unsaturated fatty acid content is high in algal oils and their presence reduces the efficiency of esterification to produce biodiesel [39].

Value chain stages of biodiesel production from microalgae can be given as algae and site selection, algae cultivation, harvesting, filtration, dewatering, oil extraction and biodiesel production [39].

### 3. Biodiesel production from microalgae

The selection of species depends on some factors like ability to usage of nutrition or grow under specific environment conditions. All these parameters should be evaluated for biodiesel production.

#### 3.1. Selection of algae strain and location

To make algal biodiesel cost effective lots of researchers keep going on algae culturing. The criteria to select location and sources are mentioned below [46]:

- Water sources and demand, salinity, content
- The region information such as topography, geology
- Weather conditions, isolation, evaporation
- Availability of carbon and food resources

The next decision should be on the algae culturing process type. It can be either batch or continuous process. Depending on microalgae strain, environmental conditions, availability of nutrition and moreover industrial pollutions the process type has to be selected. The devices and apparatuses also have to be adjusted for these conditions and nutrients [39].

Algae strains have different contents, different doubling time (the total biomass per time and volume) and resistance to change in environmental conditions. Biodiesel production directly depends on the oil content of microalgae and its efficiency. So that, even the process and culturing systems are selected perfectly, time and other related factors plays an important role [39].

### 3.2. Methods used for algae growth

Not only the microalgae strain is important for efficiency of oil but also growing conditions are important. There are different ways to grow algae. Each type of microalgae has a different mechanism which let them to respond different weather and environmental conditions [39, 47]. Different growing conditions affect the microalgae doubling time. There are 4 growing type basically: phototrophic, heterotrophic, mixotrophic, and photo heterotrophic. All of them will be explained in detail.

#### 3.2.1. Phototrophic growth

Microalgae are mostly thought to be phototrophic since it requires light [48]. Phototrophic growing method is based on using light and carbon dioxide to produce chemical energy during photosynthesis. This is the most common way used to grow microalgae. The best advantage of the process is using carbon dioxide as a carbon source to grow or produce fatty acid. Since carbon dioxide is only the carbon source, locations close to fabrics and companies could be selected to procure carbon dioxide. If it is compared to other growing types, phototrophic method has the lowest contamination risk [49].

#### 3.2.2. Heterotrophic growth

Some microalgae are not able to grow phototrophic conditions but they can grow in dark using organic carbon as a carbon source like bacteria. If microalgae is using organic carbon these microalgae are heterotrophic growing algae. Heterotrophic growth has advantages over phototrophic growth because light is not required. The biggest problem with the phototrophic is the light penetration when the density of the culture gets higher. In that way one of the biggest problems is solved with heterotrophic growth. Heterotrophic growth will be more cost effective compared to phototrophic growth [48]. And this method is said the most practical and promising way to increase the productivity [50-52]. Also higher oil rates and efficiency can be obtained when the algae grow heterotrophic, but the contamination risk is much higher compared to phototrophic [49].

Microalgae uses different organic carbon sources such as glucose, acetate, glycerol, fructose, sucrose, lactose, galactose, and mannose, especially growth with sugar is more efficient [49].

Mostly the organism growing heterotrophic should have adaptation property to new habitat as soon as possible since when culturing to new media the lag phase should be too short, and durability during processing in fermenters and other machines [48].

#### 3.2.3. Mixotrophic growth

Mixotrophic growth is a combination of phototrophic and heterotrophic growth. Mixotrophic growth is using organic and inorganic carbon and the process requires light because of photosynthesis. Thus the microalgae have ability to live in both conditions. Microalgae uses organic compounds and carbon dioxide as a carbon source and the released carbon dioxide are also captured with the photosynthesis. Although mixotrophic-growing meth-



od mostly is not preferred compared to heterotrophic and phototrophic growth [49], because of other advantages even so mixotrophic method is applied in some studies. For example; Park *et al.* found that biomass and lipid productivities were boosted by mixotrophic cultivation [53]. Bhatnagar *et al.* found the mixotrophic growth of some microalgae strains resulted in 3–10 times more biomass production compared to that obtained under phototrophic growth conditions [54].

#### 3.2.4. Photoheterotrophic growth

When microalgae use organic compounds as carbon sources, sometimes it requires light. The main difference between mixotrophic and photoheterotrophic is that mixotrophic growth using organic compounds as energy sources, as photoheterotrophic growth requires light as energy source. This method is mostly used for production of some beneficial metabolites; however, it is rarely used for biodiesel production [49]. Metabolisms can split into groups due to pH changes. *Chlorella vulgaris*, *Haematococcus pluvialis*, *Arthrospira (Spirulina) platensis* strains are the examples for the growth by mixotrophic, phototrophic and heterotrophic methods. *Selenastrum capricornutum* and *Scenedesmus acutus* are able to grow in phototrophic, heterotrophic, photoheterotrophic conditions [47].

Algae require more than organic carbon, sugar, protein, oil or any carbon sources. Algae cannot grow without vitamins, salts, or some other nutrients (nitrogen and phosphor). Moreover, there are lots of parameters has to be controlled during algae growth to maximize and stabilize the production. Some of these parameters are oxygen rate, carbon dioxide rate, pH, heat, light intensity and so on. When appropriate weather conditions and enough nutrients are provided microalgae grow faster. Mostly doubling time is between 3. 5 h and 24 h [39].

As a result, if we compare different methods mentioned above for microalgae growth; Heterotrophic growth is much better than the others for the application of biodiesel. These methods can produce more oil than other growing types. However, heterotrophic cultures may contaminate especially in open pond systems and result in big problems in large-scale production. Moreover, organic carbon as a carbon source is an expensive raw material and makes the process cost higher. Phototrophic growth is an easily scalable and mostly uses the carbon dioxide from exhaust gas for the production of oil. However, the efficiency of the oil is lower than heterotrophic growth because the biomass doubling time is higher and total biomass rate is lower at the end. Phototrophic method mostly preferred to set a cost effective system [49].

#### 3.2.5. Conditions for growth of algae

##### 3.2.5.1. Light

The microalgae growing photosynthetically needs light and the light intensity is the most significant limiting factor. Algae culture systems mostly use both sun and lamp light. Mostly lamp-lightened algae culture systems uses wider screens to be able to absorb more light



from the system. For photosynthetic production, at least 50 % of the volume of PBR has to get enough light [55]. Open raceway ponds, plate, plate PBR, Vertical-column PBRs, Internally-illuminated PBRs, inclined tubular type, horizontal/continuous type, bubble column and air-lift PBRs are the systems used for photosynthetic algae growth. Plate photo bioreactor is more efficient than tubular photo bioreactor because the light can penetrate to bottom more in plate design. Recent works are on closed system photobioreactors to improve the capacity. Some works are done to increase the capacity; however the light penetration becomes a major problem. Light source for open ponds is only Sun. That is why the alteration is not possible for raceway ponds. The depth of the pond that the only thing can be changed. Thus mostly researches are going on closed systems to optimize light emission. Mostly photobioreactors in lab scale are lightened by fluorescence lights from inside and outside [56]. The light wavelength should be between 600-700 nm to maximize the photosynthesis. Light intensity depends on microalgae density. Higher algae density requires higher light intensity. Light also affects the lipid content. Yeesang and Cheirsilp reported that the lipid contents in all strains increased with increasing light intensity in their study [57].

Changes in light intensity and quality can alter biofuel quality [58]. Each type of microalgae has its own optimal light absorbing point. If this point exceeds the optimum point, microalgae light absorption ratio decreases. After a specific point, light decreases the biomass production and this is called photoinhibition. Photoinhibition processes depend on time and after stress of light for a few minute biomass loss starts. 10-20 min later more than 50 % damage can be seen. Cheirsilp and Torpee investigated the effect of light intensity on growth and lipid content of marine *Chlorella sp.* and *Nannochloropsis sp.* The growth of marine *Chlorella sp.* increased when the light intensity was increased from 2000 to 8000 lux. But up to 10000 lux its growth decreased. They reported that this could be some extent of effect from photoinhibition. The growth of *Nannochloropsis sp.* continuously increased up to the maximum level when increasing light intensity up to a maximum light intensity of 10000 lux. [59]. High light intensity limited algal growth, but gave the benefit of higher lipid content and yield. It can be seen in Ruangsomboon's study whose cultures exposed to low light intensity showed a higher biomass compared to others [60].

To increase the microalgae production, photoinhibition should be cut off or exceed to high light intense. In addition, photorespiration decreases the photosynthetic efficiency. Therefore the process has to avoid photorespiration. Photorespiration occurs when the oxygen concentration increases depending on carbon dioxide [56].

Sara et al. investigated the light effects on microalgae. The research was done by using red and blue lasers as light source for photosynthetic growth of green algae. The results showed that the both blue and red lasers increased the algae cell count [61].

Allen and Arnon tested the effect of light on green algae growth. The light intensity was around 16000 lux. There were two samples. One of the samples was analyzed under 11 h darkness and 13 h light. The other sample was analyzed under light for 24 h and the results showed that the growth rate was same. However after 5 days the growth rate for the sample with 24 h light was declined [62].

The effects of light on *Parietochloris incisa* was analyzed by Solovchenko et al. The results showed that best growth was seen on high light ( $400 \mu\text{mol photons m}^{-2} \text{s}^{-1}$ ). With high light condition, total fatty acid and arachidonic amount was increased due to increase in biomass [63].

Another study (Yeh et al. ) was focused on effects of different light sources on microalgae (*C. vulgaris*) growth. In the study, three different light sources was used which are tungsten lamp, fluorescent lamp (TL5), fluorescent lamp (helix lamp). The results showed that fluorescence lamps were much better for algae growth. In an other study by Floreto et al., it was mentioned that high light intensity increased the palmitic acid and most fatty acids ratio [64].

### 3.2.5.2. Carbon dioxide

Carbon dioxide is the natural carbon source of the microalgae culture. Oxygen is releasing depending on decreasing carbon amount and it is delivered to the medium. Carbon dioxide is an general carbon source for photosynthetic microalgae. When the carbon amounts get low, oxygen is produced by photolysis of water and released to media. Since algae lives in high carbon dioxide concentration, greenhouse gases, nitrogen dioxide and atmospheric pollutants came from different sources became a food for algae. The exhausted gases can feed algae production facilities from fossil fuels and also its efficiency would be increased. Works on usage of stack gases as carbon source were done but the toxicity of the stack gas components couldn't be documented well. The amount of carbon dioxide required for the growth relates to type of microalgae and photo bioreactor. Some types of algae strains are able to keep growing in high carbon dioxide conditions, in contrast for faster growth lower carbon dioxide concentration is required [56]. Widjaja studied the effect of  $\text{CO}_2$  on growth and it was seen that this effect correlates directly to the lipid productivity since growth was enhanced tremendously by increasing the  $\text{CO}_2$  concentration [65].  $\text{CO}_2$  requirement can change up to strains. VirthieBhola et al. reported in their studies that at 15%  $\text{CO}_2$  concentration there is a 3-fold decline in biomass yield when compared to the yield produced at a 4%  $\text{CO}_2$  concentration. This suggests that the strain under study could not endure  $\text{CO}_2$  concentrations greater than 4% [66]. Also Ebrahimzadeh et al. reported that increasing  $\text{CO}_2$  injection had a significant effect on microalgae growth [67].  $\text{CO}_2$  input is also important. Sonnekus reported that the  $\text{CO}_2$  should make up 0.2 -5% of the total gas flow and being careful about the  $\text{CO}_2$  input does not lower the pH of the culture [68].

### 3.2.5.3. Heat

Algal growth is also dependent on temperature. For maximum growth there is a need to know the optimal temperature. The temperature changes also lipid production and composition [69]. The degree of unsaturation of algal membrane lipids increases if cultures are maintained at temperatures below their optimum [70]. Other than this temperature is significant for dissolubility of carbon particles, which helps carbon to be used for photosynthesis. Heat effects respiration and photorespiration more than photosynthesis. However, if carbon dioxide and light are the limiting factor, the effect of heat is not significant anymore. Optimal temperature for microalgae cultures is between 20-24 °C. This can be different according to media composition,

type of culture and strain. The most general cultured microalgae can tolerate the temperature between 16- 27 °C. The temperatures lower than 16 °C will increase the duplication time and higher than 35 °C will have a fatal effect on algae [56]. However, these ranges can be changed by environmental factors such as salinity, pH, carbon dioxide etc.

In the study of Floreta et al., the factors affecting algae growth were determined. Temperature effect was determined with salinity simultaneously. The results showed that low temperature (15 °C) with high salinity is the best choice. Low temperature increases the level of oleic and linoleic fatty acids. Moreover, high salinity increases the amount of C<sub>16</sub> and C<sub>18</sub> poly-unsaturated fatty acids [71].

#### 3.2.5.4. pH

Microalgae require different pH values according to the media. During high pH concentration, the carbon dioxide might be limiting factor for growth and photosynthesis. The most used pH range for algal growth is around 7-9. The optimal pH for algae is between 8.2- 8.7. But it can change with different strains. For example, Weissel and Stadler studied with *Cryptomonas sp.* which showed positive population growth rates over a wide pH range, from 4.4 to 9.65 [72]. Appropriate pH can be adjusted by ventilation or gassing. There is a complex relationship between CO<sub>2</sub> concentration and pH in microalgal bioreactor systems, owing to the underlying chemical equilibrium among such chemical species as CO<sub>2</sub>, H<sub>2</sub>CO<sub>3</sub>, HCO<sub>3</sub><sup>-</sup> and CO<sub>3</sub><sup>2-</sup>. Increasing CO<sub>2</sub> concentrations can increase biomass productivity, but will also decrease pH and this causes important effect upon microalgal physiology [73]. Water contaminated with a high pH has negative effects on algal abundance [74]. If there is not enough CO<sub>2</sub> gas supply, algae will utilize carbonate to maintain its growth [75].

Although high concentration of carbon dioxide provides high biomass efficiency, on the other side higher contamination risk and effect of low pH on microalgae physiology occurs [56].

Except the parameters mentioned above; there are also some parameters which affect on algal growth or lipid accumulation. Nitrogen, phosphorus and salinity can be examples for these parameters [76]. Widjaja et al. studied about nitrogen starvation effect on lipid accumulation. They reported that longer time of nitrogen starvation obviously resulted in higher accumulation of lipid inside the cells. Under all CO<sub>2</sub> concentrations, the lipid content tend to increase when the algae was exposed to nitrogen starvation condition that total lipid content was higher than lipid obtained during normal nutrition [75]. Ruangsombon found the highest biomass concentration was found under the highest phosphorus concentration [60]. Li Xinet al. have reported in their study that lipid productivity was not at its highest when the lipid content was highest under nitrogen or phosphorus limitation [77]. Yeasang and Cheirsilp also studied about nitrogen and salinity effect. They found an increase in algal biomass under nitrogen-rich condition for all strains and in the absence of a nitrogen source, no growth was observed. They reported that although some loss in algal biomass was found, the lipid contents of four strains increased. They also noticed that growth and lipid accumulation by these microalgae could be affected by salinity. Under nitrogen-rich condition, all strains survived at high salinity but growth of some strains decreased [57, 78].

### 3.3. Microalgae cultivation systems

Cultivating microalgae can be achieved in open systems like lakes and ponds and in high controlled closed systems called photobioreactor. A bioreactor is defined as a system, which carries out biological conversion. Photobioreactors are reactors, which used for prototroph to grow inside or photo biological reactions to occur [79].

#### 3.3.1. Open ponds

Generally open ponds are used in microalgae cultivation. Open ponds have various shapes and forms and certain advantages and disadvantages. In the scientific investigations and industrial applications, raceway ponds, shallow big ponds, circular ponds tanks and closed ponds are used [80]. Area where pool exist is critical factor for selection of pond type. Ponds become local climate function due to lack of control in open ponds [80, 81]. Therefore, area contributes to the success. Open ponds are limited by key growth parameters, which include light intensity, temperature, pH and dissolved O<sub>2</sub> concentration. Another problem seen in open ponds is contamination. It limits cultivation system of algae, which can grow under certain conditions [79].

Cost of cultivation systems is an important factor for comparison of open and closed systems. Construction, operation and maintaining costs are less than photobioreactors in ponds and these systems are simpler than the others [79, 82].

#### 3.3.2. Photobioreactors

Nowadays researches are made for designing photobioreactors due to cultivating microalgae. Photobioreactors offer better control than open systems [2]. Their controlled environment allows high yield for cultivating.

Productivity is the most important indicator for bioreactor technology. It is very difficult to compare productivity of bioreactors due to various strains and scale of microalgae [80].

Photobioreactors basically can be tubular and flat type. When it is compared with the other bioreactors, tubular reactors considered as more suitable for open cultivating. Large illumination surface of reactor, which made of transparent tubes, is the main factor to being suitable for cultivation. Tubes can be adjusted in various types, adjustments convenience is depend to the specification of system.

A general configuration includes straight line and coiling tubes [83]. Reactor geometry is also important, tubular reactors can be vertical, horizontal or inclined shape. There are important differences between configurations of vertical and horizontal. Vertical designs provide more mass transfer and reduce energy consumption; horizontal designs can be scaled but needs more space. There are more studies about tubular photobioreactors but usually flat type photobioreactors is preferred because it can offer high cell density [84]. In addition, this type of reactors is advantageous due to low energy consumption and high mass transfer capacity, reduction of oxygen increases, high photosynthetic efficiency, no dark volumes when compared with the other photobioreactors. Suitable reactor design should

be provided with maximum cell mass. Various flat-plate photobioreactor designs are made of glass, thick transparent PVC materials and V-shape and inclined. Although the other designs are cheap and easy to construct, glass and PVC is more transparent for maximum light penetration [80, 84-86].

#### 3.3.2.1. Flat-plate photobioreactors

These systems have large illuminated surfaces. Generally these photobioreactors are made of transparent materials to utilize the solar light with maximum degree. Dissolved oxygen concentration is low compared to the horizontal tubular photobioreactors. In this system high photosynthetic activity can achieve. Although it is very suitable for culturing algae but it has some limitations [83].

#### 3.3.2.2. Tubular photobioreactors

Most of tubular photobioreactors are made of glass or plastic tubes. They can be horizontal, serpentine, vertical, near horizontal, conical and inclined photobioreactors. Ventilation and mixing is generally performed by pump or ventilation systems. Tubular photobioreactor is suitable with their illuminated surfaces. But one of the important limitations of this system is poor mass transfer. It is a problem when photobioreactor is scaled. Also photoinhibition is seen in photobioreactors [83, 87].

If there is not sufficient mixing system cells don't have enough light for their growth. Developing mixing systems can provide effective light distribution.

Also controlling culture temperature is very difficult in these systems. Thermostat can be used but it is expensive and hard to control. Also cells can attach the walls of tubes. Long tubular photobioreactors are characterized with transfer of oxygen and CO<sub>2</sub> [83, 88].

Vertical column photobioreactors are low cost, easily constructed and compact systems. They are promising for large scale of algae production. Bubble column and airlift photobioreactors can reach specific growth rate [56].

#### 3.3.2.3. Internally illuminated photobioreactors

Florescent lamps can illuminate some photobioreactors internally. Photobioreactor is equipped with wheels for mixing algal cultures. Sprayer provides air and CO<sub>2</sub> to culture. This type of photobioreactors can utilize solar light and artificial light [90]. When solar light intensity is low (night or cloudy day) artificial light is used. Also in some researches, it is told that solar light can be collected and distributed with optic fibers in cylindrical photobioreactors [91]. Another advantages of this system are can be sterilized with heat under pressure and minimizing the contamination [56, 83].

#### 3.3.2.4. Pyramid photobioreactor

The Pyramid photobioreactor is using fully controlled and automatic system that increases the production rate. With this system, it is easy to grow any microalgae at any climate

conditions. The design is in pyramid shape to absorb light more effectively. As mentioned above, light is one of the significant parameters affecting algae growth rate and with this recent system algae can be supplied with optimal light intensity. That is why the shape of the system is the last innovation for production step. So, having optimal light intensity during high microalgae production decreases the energy consumption. The body design is angled to reduce to pump costs by using air-lifting method and decrease the deformation on cell walls. Thermo-isolated and high technologic materials are used to avoid energy lost and over heating [92].

### 3.4. Biocoil microalgae production system

Biocoil is a holozoic tubular photobioreactor which made of plastic tubes with small diameter (between 2.4-5 cm), centrifuges, diaphragm pumps or peristaltic pumping are utilized in this system. Biocoil design provides equal mixing and reduces the attachment of algae to the walls. It automates the production process. It is not suitable for all algae species. Some of algae species damages by circulation system and some of them attach to the internal surface of tubes and affects algae production negative. In this system, when the level of algae increases maximum degree, because of the light limitation photosynthesis can slow. Biocoil systems with utilizing solar light in or outsides can executable. Light is given with an angle so algal cell can utilize better and photosynthesis occurs easily [89, 93, 94].

#### 3.4.1. Design of culture growth systems

Depends of local conditions and suitable materials various culture systems can be designed by various sizes, shapes of construction material, slope and mixing type. These factors affect performance, cost and resistance. To construct suitable photobioreactor material has main importance. Materials like plastic or glass relax and rigid shouldn't be toxic, they should have mechanical power, resistance, chemical stability and low cost. Tubular photobioreactors are the most suitable ones for open culture systems. They have big illumination surface, good biomass productivity and they aren't expensive because they are made of glass or plastic tubes. Flat-type photobioreactors are made of transparent materials to utilize solar light energy in maximum degree. This type of photobioreactors allows good immobilization of algae and they are cleaned easily [56]. Pond walls and deep side can made of simple sand, clay, brick or cement even PVC, glass fiber or polyurethane. For coating mostly long lasting plastic membrane is used. (e. g., 1-2 mm thick, UV-resistant, PVC or polyethylene sheets) sometimes to lower the cost uncoating ponds are used but that time some problems occur like contamination, a layer of mud and sand [39].

#### 3.4.2. Mixing

Mixing is a process for increasing the productivity of biomass in photobioreactors. Mixing provides distribution of light intensity, sufficient CO<sub>2</sub> transfer and maintains uniform pH. Mixing is necessary for preventing algae sedimentation and avoiding cell attachment to the reactor wall. Mixing is also provides equal light and nutrients to all cells and increases the gas transfer between culture medium and air [95]. The second of priority measures is carbon

supply for using in photosynthesis. In very dense cultures, CO<sub>2</sub> from air (includes 0.035 % of CO<sub>2</sub>) and bubbles during the culture can be limited for algal growth. CO<sub>2</sub> addition creates a buffer for the result of changing pH in the water [56].

Poor mixing allows cells to clumping like different size of aggregates; therefore it leads 3 phase (solid-liquid-gas) system in reactor. This situation tends to reduce the mass transfer. But all algae cannot tolerate agitation. Because they are sensitive to hydrodynamic stress. High mixing rate can cause the damaging of cells. Mixing in bubble column and air lift reactors can characterize with axial dispersion coefficient, mixing time, circulation time and Bodenstein number [96]. Analysis of mixing in bubble column shows it has shorter time than airlift reactors. Bubbles beyond the suction pipe provide less blurry area and causes better exposure to the light. In addition, existence of suction pipe in airlift reactors causes more effective mixing because internal loop provides a circulation. Airlift reactor gives information about fluid flow and high gas-liquid mass transfer rate. Bubble column causes unbalance cell density and these causes to death of algae [56, 97].

#### *3.4.3. Light penetration*

Another key of successfully scale up is light penetration. Illumination in the photobioreactor affects biomass composition, growth rate and products. Microalgae need light for their photosynthesis [98]. Photosynthetic active radiation wave changes about 400-700 nm and this is equal to the visible light [99]. In intense cultures, light gradient changes over the photobioreactor radius due to the weakening of the light. Reduction of light intensity related to wave length, cell concentration, photobioreactor geometry and distance of the light transmittance. Light intensity in photobioreactor related to light way, cell concentration and light which emits by microalgae [56].

#### *3.4.4. Gas injection*

Supplement of CO<sub>2</sub> by bubbles is an important factor to be considered in designs. Injection of CO<sub>2</sub> bases on giving CO<sub>2</sub> to photobioreactor artificially. Researches show that rich ventilation of CO<sub>2</sub> provides CO<sub>2</sub> to algae, supports deoxygenation of suspension, to improve cycling provides mixing and limits the light inhibition [100]. But high ventilation rate leads to higher cost that is why in large scale of microalgae production it is not recommended. These researches results for microalgae production necessary optimum aeration rate of CO<sub>2</sub> gas. Includes about 5% or 10% of CO<sub>2</sub> (v/v), rate of 0.025-1 vvm [100]. Volume of air/medium/time is found cost effective for air mass culture [56].

#### *3.4.5. Comparison of open and closed culture systems*

Open and closed culture systems have advantages and disadvantages. Construction and operation of open culture systems are cheaper and they are more resistant than closed reactors and have large production capacity [101]. Ponds use more energy to homogenize to nutrients and to utilize the solar energy for growth their water level cannot be less than 15 cm [41]. Ponds are exposing to air conditions because water temperature evaporation and illu-



mination cannot be controlled. They produce large amounts of microalgae but they need larger areas than closed systems and they are open to other contaminations from the other microalgae and bacteria. Also when atmosphere has only 0.03-0.06 % of CO<sub>2</sub>, mass transfer limitation slows the growth of microalgae cell.

Photobioreactors are flexible systems, which can operate for biological and physiological characteristics of cultured microalgae. It can be possible to produce microalgae, which cannot produce in ponds. Exchange of gas and contaminants between atmosphere and cultured cells in photobioreactor is limited or blocked by reactor walls [39]. Depends on the shape and design, photobioreactors have more advantages than open ponds. Culture conditions and growth parameters can be controlled better, it prevents evaporation, reduces loss of CO<sub>2</sub>, provides high microalgae density or cell concentration, high yield, creates more safe and preserved environment, prevents contamination. Despite the advantages, photobioreactors have problems to be solved. Over heating, biological pollution, accumulation of oxygen, difficulty of scale-up, high cost of construction and operation and cell damage because of shear stress and degradation of material in photo phase are main problems in photobioreactors [39].

Comparing photobioreactors and open ponds is not easy because growth of algae related to a lot of different factors. Three parameters are considered in algae production units for yield [41]:

- Volumetric productivity (VP): productivity per unit reactor volume (expressed as g/L. d).
- Areal productivity (AP): productivity per unit of ground area occupied by the reactor (expressed as g/m<sup>2</sup>d).
- Illuminated surface productivity (ISP): productivity per unit of reactor illuminated surface area (expressed as g/m<sup>2</sup>d).

According to researches closed systems don't provide advantage for areal productivity but provide volumetric productivity (8 times) and cell concentration (16 times) more than open ponds [39, 41].

#### 3.4.6. Comparison of batch and continuous process

Photobioreactors can be operated in batch or continuous process. There are a lot of advantages for using continuous bioreactors than batch bioreactors. Continuous bioreactors provide more control than batch bioreactors. Growth rates can be regulating in long time periods, can be saved and with variable dilution rates biomass concentration can be controlled. With steady state continuous bioreactors results is more dependable, products can be easily produced and can be reached desired product quality. Continuous reactions offer many opportunities for system research and analysis [102].

But some type of bioreactors is not suitable for continuous process. For some productions, cell aggregation and wall growth can inhibit the steady state growth. Another problem is loss of original product strain in time. Mixtures viscosity and heterogenic nature make diffi-

cult for maintaining filamentous organisms. Long growth periods increase the contamination risks [83].

### 3.5. Harvesting alternatives

There are several ways to harvest microalgae and dry them. Some main harvesting methods are sedimentation, flocculation and filtration.

*Sedimentation:* When a particle moves continuously in a phase, the velocity is affected by two factors. First of them is increasing the velocity because the density gradient between particle and fluid create buoyant force. At the end, buoyant force gets equal to dragging force and particle starts moving with a constant velocity. The same idea is applied to collect microalgae from the ponds. Gravity force is used for settling of suspended particles in fluid. This method is cheap and easy. However, the particles suspended in the fluid have to be incompressible. The problem with the *Scenedesmus sp.* and *Chlorella sp.* is that they are compressible. That is why sedimentation cannot be used for these types [103]. For low value products, sedimentation might be used if it is improved with flocculation [104].

*Flocculation:* is also used for harvesting microalgae. The general idea is microalgae carries negative charge on it and if the flocculants disappear the negative charge, algae starts coagulation. Some used flocculants are  $Al_2(SO_4)_3$ ,  $FeCl_3$ ,  $Fe_2(SO_4)_3$  [105].

*Filtration:* This is one of the most competitive methods for the collection of algae. There are different types of filtrations, for example, dead end, microfiltration, ultrafiltration, pressure filter and vacuum filter. Mostly filtrations require the liquid media with algae to come through filtration. Filter can be fed until a thick layer of microalgae is collected on the screen. This method is very expensive for especially microalgae. The pore sizes of the filters are the most important part. If the pore size is bigger than algae you cannot collect it. In contrast, if the pore size is too small it might result in decrease of the flow rate and block the pores [106].

### 3.6. Extraction of lipid from microalgae

There are a lot of methods for extraction of lipid from microalgae but the most common techniques are oil presses, liquid-liquid extraction (solvent extraction), supercritical fluid extraction (SFE) and ultrasonic techniques. Oil presses are usually used for extracting of lipids from nuts and seeds. The same process and devices can be used for lipid extraction from microalgae. For the purpose of this process to be effective, firstly microalgae must be dried. Presses use pressure for breaking cells and removing oil [107]. This method can extract 75% of oil but in longer extraction times it is less effective [80].

Solvent extraction is more successful for extracting lipids from microalgae. In this method organic solvents such as hexane, acetone, and chloroform are added in the algae paste. Solubility of oil is higher in organic solvents than water. Therefore solvent breaks the cell wall and extracts oil easily. Solvent extraction continues with distillation process for separating oil from the solvent [108]. Hexane is cheap and has high extraction capacity. For this reason it is reported to be the most effective solvent in extractions.

In addition to this studies, 2 stage process using ethanol improves lipid extraction. The yield of recovery of oil reaches about 80%. Butanol is also effective in extraction of lysophospholipids. But evaporation of butanol is difficult and there are some impurities because of its high polarity [80].

Supercritical extraction uses high pressure and temperature for breaking cells. This method is widely used and efficient for extraction time. Studies reported that temperature and pressure don't affect the yield of components but it affects extraction rate. Similar effects are seen in SFE system and solvent extraction [109].

Another method is using ultrasonic techniques. In this method microalgae is exposed to high intensity ultrasonic waves and these waves creates bubbles around the cell. Shock waves are emitted by collapsing bubbles. It breaks cell wall and desired components release to the solution. This method is also improves the extraction rate with the same way. This technique is widely used in laboratory scale but in commercially scale there is not enough information about cost and applicability [110, 80].

### **3.7. Biodiesel Production from Oil**

After extraction there are 4 main methods for producing biodiesel: direct used and mixing with raw oils; microemulsion; pyrolysis and transesterification.

#### *3.7.1. Dilution*

This is a dilution method that certain proportion of vegetable and waste oils blended with diesel fuel and another solvent. The most used oils for producing biodiesel with this way are waste oils and vegetable oils like sunflower and rapeseed.

Direct use or blending generally considered being unsatisfactory and impractical for both direct and indirect diesel engines. There are specific problems such as high viscosity, acid composition, free fatty-acid content, gum formation because of oxidation, polymerization during storage and combustion, carbon deposits and also lubricating-oil thickening [111].

Dilution of vegetable oils with solvents lowers the viscosity. The viscosity of oil can be lowered by blending with pure ethanol [112]. The low viscosity is good for better performance of engine, which decreases with increasing the percentage of diesel [33]. In this method there is no chemical process and viscosity can be lower but there are also carbon deposits and lube pollution problems to be solved. To solve problems caused by high viscosity, micro-emulsion, pyrolysis and transesterification methods are used [113].

#### *3.7.2. Micro-emulsion*

It is defined that the size of 1-150 nm, the two immiscible liquid organic mixtures with ionic or non-ionic, self-formed stable colloidal distribution. With this method it is possible to form alternative diesel fuels except petroleum [28]. In this method vegetable oils with an ester and dispersant (co-solvent), or of vegetable oils, an alcohol and a surfactant, with or without diesel fuels can be used to make a microemulsion. Due to their alcohol contents, microemul-

sions have lower volumetric heating values than diesel fuels. But these alcohols have high latent heats of vaporization and also tend to cool the combustion chamber, which cause a reduction of nozzle coking. A microemulsion made of methanol and vegetable oils can perform like diesel fuels [111]. To solve the problem of the high viscosity of vegetable oils, microemulsions with solvents and immiscible liquids, such as methanol, ethanol, 1-butanol and ionic or non-ionic amphiphiles have been studied [114].

### 3.7.3. Pyrolysis

Pyrolysis is the conversion of organic substance into another by means of heat or by heat in the presence of a catalyst. Vegetable oil, animal fat, algae oil, natural fatty acids or methyl esters of fatty acids can be pyrolyzed [111]. Although this method is not very cheap, however, fuel can be produced without extraction of lipids or hydrocarbons. More uniform product can be obtained and ideally increases yields over transesterification with this method [115]. Products are chemically similar derived from petroleum products, which are to gasoline and diesel fuel derived [28]. Also with pyrolysis some low value materials and sometimes more gasoline than diesel fuel are produced [116]. In comparison between pyrolysis and the other cracking processes, pyrolysis is seen more simple, pollution free and effective [33]. Sharma et al. reported that pyrolysis of the vegetable oil can produce a product which has high cetane number, low viscosity, acceptable amounts of sulfur, water and sediments contents, acceptable copper corrosion values [117].

### 3.7.4. Transesterification

Transesterification of the oil is the most promising solution to the high viscosity problem [114]. In this process, triglycerides are converted to diglycerides, then the diglycerides are converted to monoglycerides, and the monoglycerides are converted to esters (biodiesel) and glycerol (by-products) [118]. There are three common kinds of catalysts used in transesterification process such as lipase catalysts, acid catalysts and alkali catalysts. Each catalyst has advantages and disadvantages [113].

In the acid-catalytic transesterification, the reaction can be catalyzed by sulfuric, phosphoric, hydrochloric and organic sulfonic acids. Very high yields can be obtained by using this catalyst. These reactions need the use of high alcohol-to-oil molar ratios in order to obtain good product yields in practical reaction times. But ester yields do not proportionally increase with molar ratio and the reaction time is very long (3–48 h) [114, 119, 120]. Xu et al. studied the acidic transesterification of microalgae (*Heterotrophic C. Protothecoides*) oil. They used methanol for alcohol and they achieved 80% of FAME yield [121].

Johnson made a study on *Schizochytrium limacinum* microalgae species. He converted this algal oil to biodiesel with acidic transesterification and he achieved 82.6% of biodiesel yield [122].

In the alkali-catalytic transesterification, the reaction can be catalyzed by alkaline metal alkoxides, and hydroxides, as well as sodium or potassium carbonates. Sodium methoxide is the most widely used biodiesel catalyst. This reaction is faster than acid-catalytic transesterification and reactions can occur in low temperatures with a small amount for catalyst and

with little or no darkening of colour of the oil [114]. High quality can be obtained however this process is very sensitive to the presence of water and free fatty acids and needs lots of methanol. If the raw materials have a high percentage of free fatty acids or water, the alkali catalyst reacts with the free fatty acids to form soaps [113]. There are some studies on microalgae oil to produce biodiesel by using alkali transesterification. Velasquez-Orta et al. studied on biodiesel production from *Chlorella vulgaris*. In that study, alkali transesterification was used for conversion and they achieved 71% of FAME yield [123]. Ferrentino et al. studied on biodiesel production from microalgae too. They used *Chlorella* sp. oil and their production method was alkali transesterification. They have obtained high yield from their experiment [124]. In another study, Carvalho et al. used alkali transesterification for biodiesel production from algae oil. In their study, they used *Chlorella emersonii* oil and they have obtained 93% conversion yield [124].

It can be seen that there are some problems such as recovery of glycerol or removing catalysts from product and need of wastewater treatment in acid or alkali-catalytic transesterification. Enzymatic catalysts like lipases are able to catalyze the transesterification of triglycerides effectively. With this process glycerol can be easily recovered however enzymatic catalysts are often more expensive than chemical catalysts. The high cost of enzyme production is the main obstacle to the commercialization of enzyme-catalyzed processes. But using solvent-tolerant lipases and immobilized lipases can be a solution for this. Lipase-catalyzed transesterification is considered to be one of the most effective reactions for production of biodiesel [114]. In another study Tran et al. used microalgae oil (*Chlorella vulgaris* ESP-31) for producing biodiesel. Their method was enzyme-catalyzed transesterification and they used lipase in this process. In the result, they reported that they achieved 94.78 % of FAME yield [126]. Table 2 presents the transesterification studies for biodiesel production from microalgae oil.

Supercritical process, microwave-assisted method and ultrasonic-assisted process are novel methods used in biodiesel production area. Since these methods are novel methods and also algae are new materials for biofuel area, there is a few studies biodiesel production from algae oil with these novel methods, these studies were reviewed and presented below.

With *supercritical process* biodiesel production can be easily achieved without catalysts. Supercritical fluid is a substance whose temperature and pressure is above the critical point. These fluids are environmentally friendly and economic. Usually water, carbon dioxide and alcohol is used for supercritical fluid. In biodiesel production generally supercritical methanol and supercritical ethanol is used. Advantages of this process are being easier for purification, shorter the reaction time and more effective reaction [130]. In the study of Patil et al., using supercritical methanol produced biodiesel. The wet algae were used and the ratio of alcohol/ oil was chosen as 9:1. The temperature of the reaction occurred at 255 and 1200 psi and resulted in 90% of FAME yield [131].

*Microwaves* activate differences in small degrees of polar molecules and ions, because the molecular friction and chemical reactions start. Molecules have not the enough time to relax and heat generation occurs in a short time because energy interacts with molecules very quickly. Transesterification reaction is carried out with microwave in a short time and mi-

crowave results in an efficient manner. As a result in a short time separation and pure products with high yield is obtained. Thus, production costs and the formation of by-product are reduced [130]. Patil et al., made a study on biodiesel production from dry microalgae by using microwave-assisted process. KOH was used as catalyst in the study and microwave condition is set to 800 W. The performance of the study is around 80% [132]. The other study with macroalgae for microwave-assisted algal biodiesel was showed that methanol to macroalgae ratio of 1:15 was the best condition. In the study, sodium hydroxide concentration was 2 wt % and reaction time of 3 min for the best condition [133]. Koberg et al. was reported the study used *Nannochloropsis* for algal biodiesel production with microwave-assisted method. The higher biodiesel yield was observed which was around 37.1% with microwave technique. The same conditions for sonication technique resulted in lower yield [134].

Algae strain	Method	Alcohol	Alcohol / oil molar ratio	Temp.	Time	Results	Ref.
<i>Heterotrophic C. Protothecoides (microalga)</i>	Acidic transesterification	Methanol	56:1	30 °C	4 h	80% (FAME Yield)	[121]
<i>Chlorella vulgaris ESP-31 (microalga)</i>	Enzymatic transesterification (Lipase)	Methanol	98.81	25-40 °C	48 h	94.78% (FAME Yield)	[126]
<i>Chlorella vulgaris (microalga)</i>	in situ alkaline transesterification	Methanol	600:1	60 °C	75 min	71% (FAME Yield)	[123]
<i>Nannochloropsis oculata (microalga)</i>	heterogeneous transesterification	Methanol	30:1	50 °C	4 h	97.5% (FAME Yield)	[127]
<i>Chlorella (microalga)</i>	In-situ acidic transesterification	Methanol	315:1	23 and 30 °C	15 min-2 h	70-92% (FAME Yield)	[17]
<i>Chlorella sp. (microalga)</i>	Alkali Transesterification	Methanol	-	100 °C	25 h	90 (Fluorometric Reading)	[124]
<i>Schizochytrium limacinum (microalga)</i>	Acidic Transesterification	Methanol	-	90 °C	40 min.	82.6% (biodiesel Yield)	[122]
<i>Chlorella emersonii</i>	Alkali transesterification	Methanol	5:1	60 °C	2 h	93% conversion	[125]
<i>Fucus spiralis (macroalga)</i>	Alkali Transesterification	Methanol	6:1	60 °C	4 h	1.6-11.5% (Process Yield)	[128]
<i>Commercially refined macroalga (Kelp)</i>	McGyan process	Methanol	32:1	360 °C	30 s	94.7% (FAME Yield)	[129]

**Table 2.** The transesterification studies for biodiesel production from microalgae oil

Recent years, *ultrasonic-assisted process* is widely used in biodiesel production. Mixing is very important factor for biodiesel yield in transesterification reactions. It is an effective mixing method in liquid-liquid mass transfer to provide better mixing. Powerful mixing creates smaller droplets than the conventional mixing and increases the contact areas between the oil phases. Also it provides the activation energy, which needs for initiating transesterification reactions [130]. In the study of Eihaze et al., they are focused on the in situ transesterification of microalgae by ultrasound technique. The reaction takes 1 h with the use of methanol/oil ratio to 315:1. The result was  $0.295 \pm 0.003$  g biodiesel/g dry *Chlorella* which shows that this is higher than mechanically stirred in situ technique [135].

### 3.8. Design of algae and biodiesel production

In this section of study, algae production stages that cover the algae strain and location selection, algae cultivation, harvesting, oil extraction, and biodiesel production process from microalgae are presented by using ChemCad design program. All stages are given in this process flow diagram (pfd) and equipment table in detail. As it is seen in a process flow diagram (pfd), the streams between 1-8 are the area of the process where algae growth occurs. The algae bodies contain a lipid, which can be extracted and converted into a type of biofuel. The area where between stream 1-8 has several large ponds to grow algae containing large amounts of lipid in preparation for lipid extraction. Once a pond is harvested, it is re-inoculated for another crop of algae (stream 11-13). Once the algae reach maturity in the growth ponds and have the desired lipid content, the cells are harvested in the area where stream 9-10. This area at a concentration of 1g-algae/L water. The algae collected will be dewatered, and the usable lipid is extracted for the reaction process where stream 9,10,14-16. The remaining algal biomass will be sent to algal pulp tank, it may be evaluated for biogas production in digesters. Lipids, catalysts and alcohol are sent for fuel conversion to heat-jacketed transesterification reactor. Once the lipid is harvested from the algae cells, the usable triglycerides are converted to biofuel in streams 16-18. Then products sent to the separator to separate biodiesel and byproduct glycerol in stream 21-27. The byproduct of this reaction is glycerol, which is removed and treated as waste. The biofuel is then ready to be used in modern farm equipment, or as a fuel supplement for diesel. All the equipments, tanks and ponds are labeled in the Figure 1.

## 4. Conclusion

Nowadays, demands on energy are caused to reduction of sources and environmental problems let the world to use alternative fuels. Microalgae have important potential as an alternative energy source. A lot of valuable products can be produced from microalgae such as biodiesel, biogas, bioethanol, medicines and nutraceuticals. Biodiesel is one of the most important alternative fuels. Microalgal biodiesel production is very new technology. In this study, microalgae and their classifications, important steps of biodiesel production from microalgae have been mentioned. In production sections, steps are explained briefly and easily understandable. Also advantages and disadvantages in the production are mainly dis-



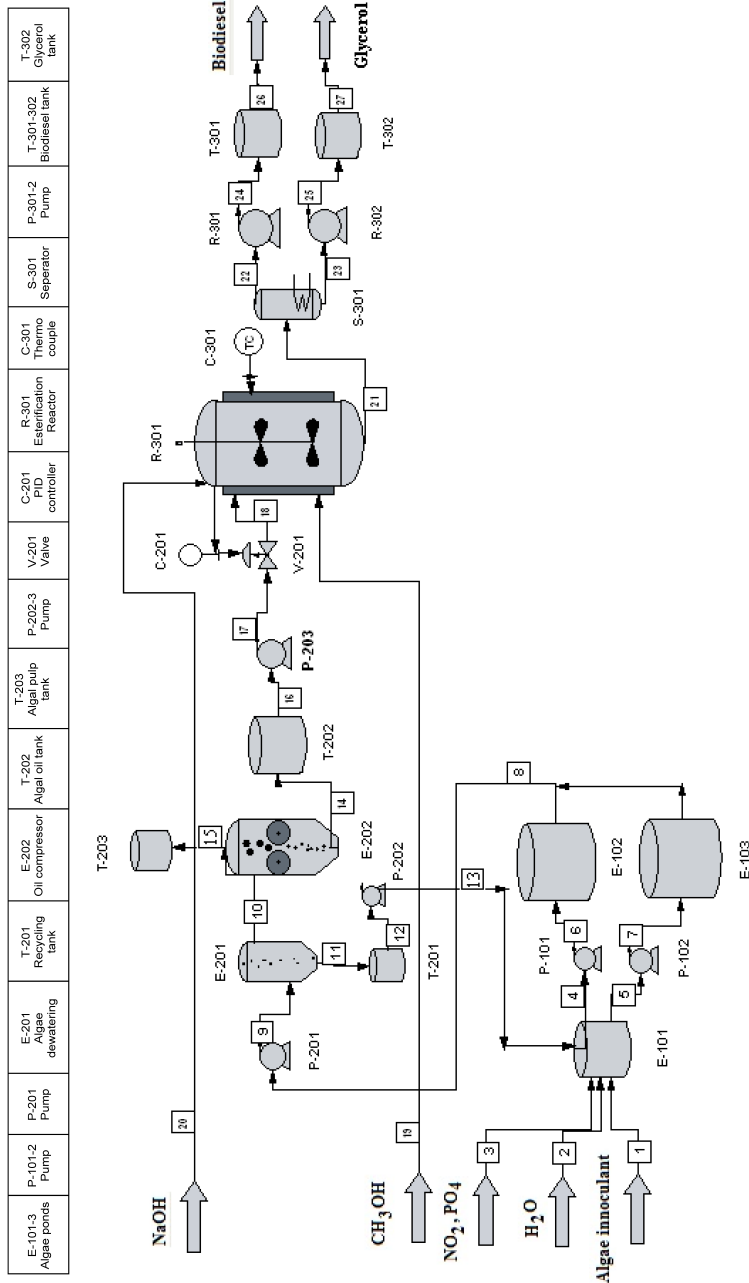

**Figure 1.** The process flow diagram of biodiesel production process from microalgae by ChemCAD.

cussed. At the end of this chapter, a biodiesel production from microalgae is designed by ChemCadprogram, which shows a simple process flow diagram for who desires to produce biodiesel from microalgae. Recently, microalgae are not economically viable. The main problems are the cost of capital cost. The rate of return is not short as it is expected. The operation cost is also affecting the total cost significantly. The main part, which makes the process expensive due to operation and capital costs, are algae growth, harvesting, dewatering, and fuel conversion. Beyond these, oil extraction step significantly increases the cost. If the oil could be extracted easily and at higher rates, the cost would be much lower. However, there are needs to innovate new ways to make the process economically feasible. Regardless, microalgae are seen as important resources for the future and there will be a lot of improvements on recent technology.

## Author details

Didem Özçimen, M. Ömer Gülyurt and Benan İnan

\*Address all correspondence to: ozcimen@yildiz.edu.tr

YıldızTechnical University, Faculty of Chemical and Metallurgical Engineering, Bioengineering Department, Istanbul, Turkey

## References

- [1] Szulczyk KR, McCarl BA. Market penetration of biodiesel. *Renewable and Sustainable Energy Reviews* 2010;14: 2426–2433.
- [2] Chisti Y. Biodiesel from microalgae. *Biotechnology Advances* 2007; 25 (3): 294-306.
- [3] Khan SA, Rashmi, Hussain MZ, Prasad S, Banerjee UC. Prospects of biodiesel production from microalgae in India. *Renewable Sustainable Energy Reviews* 2009; 13: 2361–2372.
- [4] Teixeira CM, Morales ME. Microalga como matéria-prima para a produção de biodiesel. *Revista: Biodiesel o Novo combustível do Brasil* 2007; 91–96.
- [5] Wu X, Ruan R, Du Z, Liu Y. Current Status and Prospects of Biodiesel Production from Microalgae. *Energies* 2012; 5: 2667-2682.
- [6] Yoo C, Jun SY, Lee JY, Ahn CY, Oh HM. Selection of microalgae for lipid production under high levels carbon dioxide. *Bioresource Technology* 2010; 101: 571–574.
- [7] Jiang LL, Luo SJ, Fan XL, Yang ZM, Guo RB. Biomass and lipid production of marine microalgae using municipal wastewater and high concentration of CO<sub>2</sub>. *Applied Energy* 2011; 88: 3336–3341.

- [8] Lee JN, Lee JS, Shin CS, Park S. C, Kim SW. Methods to enhance tolerances of *Chlorella* KR-1 to toxic compounds in flue gas. *Applied Biochemistry and Biotechnology* 2000; 84–86: 329–342.
- [9] Vergara-Fernandez A, Vargas G, Alarcon N, Velasco A. Evaluation of marine algae as a source of biogas in a two-stage anaerobic reactor system. *Biomass and Bioenergy* 2008; 32:338–44.
- [10] Yen HW, Brune DE. Anaerobic co-digestion of algal sludge and waste paper to produce methane. *Bioresource Technology* 2007; 98: 130–134.
- [11] Nakas JPS, Parkinson CM, Coonley CE, Tanenbaum SW. System development for linked-fermentation production of solvents from algal biomass. *Applied and Environmental Microbiology* 1983; 46:1017–23.
- [12] Belarbi EH, Molina EY. A process for high yield and scalable recovery of high purity eicosapentaenoic acid esters from microalgae and fish oil. *Process Biochemistry* 2000; 35:951–69.
- [13] Cheng-Wu Z, Zmora O, Kopel R, Richmond A. An industrial-size flat plate glass reactor for mass production of *Nannochloropsis* sp. (Eustigmatophyceae). *Aquaculture* 2001; 195:35–49.
- [14] Besada V, Andrade JM, Schultze F, Gonzalez JJ. Heavy metals in edible seaweeds commercialised for human consumption. *Journal of Marine Systems* 2009; 75:305–13.
- [15] Spolaore P, Joannis-Cassan C, Duran E, Isambert A. Commercial applications of microalgae. *Journal of Bioscience and Bioengineering* 2006; 101: 87–96.
- [16] Olaizola M. Commercial development of microalgal biotechnology: from the test tube to the marketplace. *Biomolecular Engineering* 2003; 20: 459–466.
- [17] Ehimen EA, Sun ZF, Carrington CG. Variables affecting the in situ transesterification of microalgae lipids. *Fuel* 2010; 89(3): 677–684.
- [18] Yang Z, Guo R, Xu X, Fan X, Luo S. Hydrogen and methane production from lipid-extracted microalgal biomass residues. *International Journal of Hydrogen Energy* 2011;36: 3465–3470.
- [19] Hirayama S, Ueda R, Ogushi Y, Hirano A, Samejima Y, Hon-Nami K, Kunito S. Ethanol production from carbon dioxide by fermentative microalgae. *Studies in Surface Science and Catalysis* 1998; 114:657–60.
- [20] Bush RA, Hall KM. Process for the production of ethanol from algae. U. S. Patent 7,135,308; 2006.
- [21] Gamal A. Biological importance of marine algae. *Saudi Pharmaceutical Journal* 2010; 18: 1–25.
- [22] Hasan MR. Use of algae and aquatic macrophytes as feed insmall-scale aquaculture. *FAO Fisheries and aquaculture technical paper*, 2009; 531.

- [23] Hall J, Payne G. Factors controlling the growth of field population of *Hydrodictyon reticulatum* in New Zealand. *Journal of Applied Phycology* 1997; 9: 229-236.
- [24] Rafiqul IM, Jalal KCA, Alam MZ. Environmental factors for optimisation of *Spirulina* biomass in laboratory culture. *Biotechnology* 2005; 4: 19-22.
- [25] McHugh DJ. A guide to the seaweed industry. Fisheries Technical Paper 2003; No. 441. Rome, FAO, 118.
- [26] Bruton T, Lyons H, Lerat Y, Stanley M. A Review of the Potential of Marine Algae as a Source of Biofuel in Ireland. *Sustainable Energy Ireland* 2009; 1-88.
- [27] Bold HC, Wynne MJ. Introduction to the algae structure and reproduction, second ed., Prentice-Hall Inc., Englewood Cliffs, NJ, 07632,1985; 1-33.
- [28] Guardia SD, Valls R, Mesguiche V, Brunei JM, Gulioli G. Enantioselective synthesis of (-)-bifuracadiol: a natural antitumor marine product. *Tetrahedron Letters* 1999; 40: 8359-8360.
- [29] Bennamara A, Abourrichi A, Berrada M, Charrouf M, Chaib N, Boudouma M, Garneau XF. Methoxybifur-carenone: an antifungal and antibacterial meroditerpenoid from the brown alga *Cystoseira tamariscifolia*. *Phytochemistry* 1999; 52: 37-40.
- [30] Awad NE. Biologically active steroid from the green alga *Ulva lactuca*. *Phytotherapy Research* 2000; 14: 641-643.
- [31] Choi JS, Park HJ, Jung HA, Chung HY, Jung JH, Choi WC. A cyclohexanonyl bromophenol from the red alga *Symphyocladia latiuscula*. *Journal of Natural Products* 2000; 63: 1705-1706.
- [32] Sheehan J, Dunahay T, Benemann J, Roessler P. A Look Back at the U. S. Department of Energy's Aquatic Species Program: Biodiesel from Algae 1998.
- [33] Singh SP and Singh D. Biodiesel production through the use of different sources and characterization of oils and their esters as the substitute of diesel: A review. *Renewable and Sustainable Energy Reviews* 2010; 14: 200-216.
- [34] Garson J. Marine natural products. *Natural Product Reports* 1989; 6, 143-170.
- [35] Koehn FE, Longley RE, Reed JK. Microcolins A and B, new immunosuppressive peptides from the blue-green alga *Lyngbya majuscula*. *Journal of Natural Products* 1992; 55: 613-619.
- [36] Gerwick WH, Roberts MA, Proteau PJ, Chen JL. Screening cultured marine microalgae for anticancer-type activity. *Journal of Applied. Phycology* 1994; 6: 143-149.
- [37] Trease GE, Evans WC. *Pharmacognosy*. 14th ed., W. B Saunders Company Ltd., London, Philadelphia, Toronto, Sydney, Tokyo, 1996. 18-27.
- [38] Shimizu Y. Dinoflagellates as sources of bioactive molecules. Attaway, D. H., Zabor-sky, O. R. (Eds. ), *Marine Biotechnology*, vol. 1: Pharmaceutical and Bioactive Natural Products, New York, Plenum, 1993; 391-310.

- [39] Mata MT, Martins AA, Caetano SN. Microalgae for biodiesel production and other applications: A review. *Renewable and Sustainable Energy Reviews* 2010; 14: 217–232.
- [40] Li Y, Horsman M, Wu N, Lan CQ, Dubois-Calero N. Biofuels from microalgae. *Biotechnology Progress* 2008; 24(4): 815–20.
- [41] Richmond A. *Handbook of microalgal culture: biotechnology and applied phycology*. Blackwell Science Ltd; 2004.
- [42] Renaud SM, Thinh LV, Parry DL. The gross chemical composition and fatty acid composition of 18 species of tropical Australian microalgae for possible use in mariculture. *Aquaculture* 1999; 170:147–59.
- [43] Rodolfi L, Zittelli GC, Bassi N, Padovani G, Biondi N, Bonini G, et al. Microalgae for oil: strain selection, induction of lipid synthesis and outdoor mass cultivation in a low-cost photobioreactor. *Biotechnology and Bioengineering* 2009; 102(1):100–12.
- [44] Barclay B. *Microalgae Culture Collection 1984–1985*. Microalgal Technology Research Group (MTRG) 1984; SERI/SP-231-2486.
- [45] Zhu CJ, Lee YK. Determination of biomass dry weight of marine microalgae. *Journal of Applied Phycology* 1997; 9:189–94.
- [46] Maxwell EL, Folger AG, Hogg SE. Resource evaluation and site selection for microalgae production systems May 1985; SERI/TR-215-2484.
- [47] Chojnacka K, Marquez-Rocha FJ, Kinetic. Stoichiometric relationships of the energy and carbon metabolism in the culture of microalgae. *Biotechnology* 2004; 3(1): 21–34.
- [48] Wen Z, Chen F. Heterotrophic production of eicosapentaenoic acid by microalgae. *Biotechnology Advances* 2003; 21: 273–294.
- [49] Chen C, Yeh K, Aisyah R. Cultivation, photobioreactor design and harvesting of microalgae for biodiesel production: A critical review. *Bioresource Technology* 2011; 102: 71–81.
- [50] Chen F. High cell density culture of microalgae in heterotrophic growth. *Trends in Biotechnology* 1996; 14: 421–426.
- [51] Li XF, Xu H, Wu QY. Large-scale biodiesel production from microalga *Chlorella protothecoides* through heterotrophic cultivation in bioreactors. *Biotechnology and Bioengineering* 2007; 98: 764–771.
- [52] Doucha J, Lívansky K. Production of high-density *Chlorella* culture grown in fermenters. *Journal of Applied Phycology* 2012; 24: 35–43.
- [53] Park KC., Whitney C, McNichol, JC, Dickinson KE, MacQuarrie S, Skrupski BP. Zou, J. ; Wilson, K. E. ; O’Leary, S. J. B. ; McGinn, P. J. Mixotrophic and Photoautotrophic cultivation of 14 microalgae isolates from Saskatchewan, Canada: Potential applica-

- tions for wastewater remediation for biofuel production. *Journal of Applied Phycology* 2012; 24: 339–348.
- [54] Bhatnagar A, Chinnasamy S, Singh M, Das KC. Renewable biomass production by mixotrophic algae in the presence of various carbon sources and wastewaters. *Applied Energy* 2011; 88: 3425–3431.
- [55] Ogbonna JC, Yada H, Tanaka H. Light supply coefficient: A new engineering parameter for photobioreactor design, *Journal of Fermentation and Bioengineering* 1995; 80 (4): 369-376.
- [56] Bitoga J. P, Lee I. -B, Lee C. -G, Kim K. -S, Hwang H-S, Hong S. -W, Seo I. -H, Kwon K. -S, Mostafa E. Application of computational fluid dynamics for modeling and designing photobioreactors for microalgae production, *Computers and Electronics in Agriculture* 2011; 76: 131–147.
- [57] Yeesang C, Cheirsilp B. Effect of nitrogen, salt, and iron content in the growth medium and light intensity on lipid production by microalgae isolated from freshwater sources in Thailand. *Bioresource Technology* 2011; 102 (3): 3034-3040.
- [58] Converti A, Casazza AA, Ortiz EY, Perego P, Del Borghi M. Effect of temperature and nitrogen concentration on the growth and lipid content of *Nannochloropsis oculata* and *Chlorella vulgaris* for biodiesel production. *Chemical Engineering and Processing: Process Intensification* 2009; 48 (6): 1146-1151.
- [59] Cheirsilp B, Torpee S. Enhanced growth and lipid production of microalgae under mixotrophic culture condition: Effect of light intensity, glucose concentration and fed-batch cultivation, *Bioresource Technology*, 2012; 110: 510-516.
- [60] Ruangsomboon S. Effect of light, nutrient, cultivation time and salinity on lipid production of newly isolated strain of the green microalga, *Botryococcus braunii* KMITL 2. *Bioresource Technology* 2012; 109: 261-265.
- [61] Sara S. Kuwaharaa, Joel L. Cuelloa, Graham Myhreb, Stanley Pau. Growth of the green algae *Chlamydomonas reinhardtii* under red and blue lasers. *Optics and Lasers in Engineering*, 2010; 49: 434-438.
- [62] Allan MB, Arnon DI. Studies on nitrogen-fixing blue-green algae. I. Growth and nitrogen fixation by *Anabaena cylindrica* Lemm. *Plant Physiology* 1955; 30:366–372.
- [63] Solovchenko AE, Khozin-Goldberg I, Didi-Cohen S, Cohen Z, Merzlyak MN Effects of light intensity and nitrogen starvation on growth, total fatty acids and arachidonic acid in the green microalga *Parietochloris incise*. *Journal of applied Phycology* 2008; 20:245–251.
- [64] Yeh KL, Chang JS. and Chen WM. Effect of light supply and carbon source on cell growth and cellular composition of a newly isolated microalga *Chlorella vulgaris* ESP-31. *Engineering in Life Science* 2010; 10: 201–208.

- [65] Widjaja A, Lipid production from microalgae as a promising candidate for biodiesel production. *Makara Teknologi* 2009, 13(1): 47-51.
- [66] Bholu V, Desikan R, Santosh SK, Subburamu K, Sanniyasi E, Bux F. Effects of parameters affecting biomass yield and thermal behaviour of *Chlorella vulgaris*, *Journal of Bioscience and Bioengineering* 2011; 111 (3): 377-382.
- [67] Ebrahimzadeh MM. Torkian Boldaji SA. Hosseini Boldaji, Sh. Ettehad. Effects of varying sodium nitrate and carbon dioxide quantities on microalgae growth performance of a designed tubular photobioreactor and a channel photobioreactor. *Iranian Journal of Plant Physiology* 2011; 1(4): 257-263.
- [68] Sonnekus MJ, Effects of Salinity on the Growth and Lipid Production of Ten Species of Microalgae from the Swartkops Saltworks: A Biodiesel Perspective Nelson Mandela Metropolitan University, 2010.
- [69] Sheng J, Kim H. W, Badalamenti J. P, Zhou C, Sridharakrishnan S, Krajmalnik-Brown R, Rittmann BE, Vannela R. Effects of temperature shifts on growth rate and lipid characteristics of *Synechocystis* sp. PCC6803 in a bench-top photobioreactor. *Biore-source Technology* 2011; 102 (24): 11218-11225.
- [70] Sivakumara G, Xua J, Thompsonb RW, Yangc Y, Randol-Smithd P, Weathersc PJ. Integrated green algal technology for bioremediation and biofuel, *Bioresource Technology* 2012; 107: 1-9.
- [71] Floreto EAT, Hirata H, Ando S, Yamasaki S. Effects of Temperature, Light Intensity, Salinity and Source of Nitrogen on the Growth, Total Lipid and Fatty Acid Composition of *Ulva pertusa* Kjellman (*Chlorophyta*)" *Botanica Marina*, 2012; 36 (2): 149-158.
- [72] Weisse T, Stadler P. Effect of pH on growth, cell volume, and production of freshwater ciliates, and implications for their distribution. *Limnology and Oceanography* 2006; 51: 1708-1715.
- [73] Kumar A, Ergas S, Yuan X, Sahu A, Zhang Q, Dewulf J, Malcata F. X, Langenhove H. Enhanced CO<sub>2</sub> fixation and biofuel production via microalgae: Recent developments and future directions. *Trends in Biotechnology* 2010; 28(7): 371-380.
- [74] Bergstrom C, McKeel C, Patel S. Effects of pH on algal abundance: a model of Bay Harbor, Michigan, Biological Station of University of Michigan, 2007.
- [75] Widjaja A, Chien CC, Ju YH. Study of increasing lipid production from fresh water microalgae *Chlorella vulgaris*, *Journal of the Taiwan Institute of Chemical Engineers* 2009; 40(1):13-20.
- [76] Moisander PH, McClinton E. and Paerl HW. Salinity Effects on Growth, Photosynthetic Parameters, and Nitrogenase Activity in Estuarine Planktonic Cyanobacteria 2002; 43(4): 432-442.



- [77] Xin L, Hong-ying H, Ke G, Ying-Xue S. Effects of different nitrogen and phosphorus concentrations on the growth, nutrient uptake, and lipid accumulation of a freshwater microalga *Scenedesmus* sp. *Bioresource Technology* 2010; 101 (14): 5494-5500.
- [78] Lin Q, Lin J. Effects of nitrogen source and concentration on biomass and oil production of a *Scenedesmus rubescens* like microalga, *Bioresource Technology* 2011; 102 (2): 1615-1621.
- [79] Harun R, Singh M, Forde GM, Danquah MK. Bioprocess engineering of microalgae to produce a variety of consumer products, *Renewable and Sustainable Energy Reviews* 2010; 14: 1037-1047.
- [80] Borowitzka MA. Commercial production of microalgae: ponds, tanks, and fermenters, *Progress in Industrial Microbiology* 1999; 35 (C): 313-321.
- [81] Masojidek J, Torzillo G. Mass cultivation of freshwater microalgae. *Ecological Engineering*. *Encyclopedia of Ecology* 2008; 3: 2226. 2235.
- [82] "Biodiesel from Algae Oil", [www.oilgae.com](http://www.oilgae.com), Access date: May 10, 2012.
- [83] Ugwu CU, Aoyagi H, Uchiyama H. Photobioreactors for mass cultivation of algae. *Bioresource Technology* 2008; 99: 4021-4028.
- [84] Hu Q, Guterman H, Richmond A. A flat inclined modular photobioreactor for outdoor mass cultivation of photoautotrophs. *Biotechnology and Bioengineering* 1996; 51:51-60.
- [85] Ramos de Ortega A, Roux JC. Production of *Chlorella* biomass in different types of flat bioreactors in temperate zones. *Biomass* 1986; 10:141-56.
- [86] Iqbal M, Grey D, Stepan-Sarkissian F, Fowler MW. A flat-sided photobioreactor for culturing microalgae. *Aquacultural Engineering* 1993 ;12: 183-90.
- [87] Vonshak A, Torzillo G. Environmental stress physiology. In: Richmond, A. (Ed. ), *Handbook of Microalgal Culture*. Blackwell Publishers, Oxford, 2004; 57-82.
- [88] Camacho Rubio F, Acie 'n Ferna 'ndez F. G, Sa 'nchez Pe 'rez J. A, Garcı 'a Camacho F, Molina Grima, E. Prediction of dissolved oxygen and carbon dioxide concentration profiles in tubular photobioreactors for microalgal culture. *Biotechnology and Bioengineering* 1999; 62: 71-86.
- [89] Yılmaz HK. Mikroalg Üretimi İçin Fotobiyoreaktör Tasarımları, MEU. Su Ürünleri Fakültesi, (2006).
- [90] Ogbonna JC, Soejima T, Tanaka H. An integrated solar and artificial light system for internal illumination of photobioreactors. *Journal of Biotechnology* 1999; 70: 289-297.
- [91] Mori K. Photoautotrophic bioreactor using visible solar rays condensed by fresnel lenses and transmitted through optical fibers. *Biotechnology and Bioengineering Symposium* 1985; 15: 331-345.

- [92] "Microalgae production", SOLEY INSTITUTE, [www.algaeinstitute.com](http://www.algaeinstitute.com)
- [93] Harun R, Davidson M, Doyle M, Technoeconomic analysis of an integrated microalgae photobioreactor, biodiesel and biogas production facility. *Biomass and Bioenergy* 2011; 35: 741-747.
- [94] Kennedy CA, In Home Photosynthetic Bioreactor. *Advanced Biology* 1998.
- [95] Carvalho AP, Meireles LA, Malcata FX. Microalgal reactors: a review of enclosed system designs and performances. *Biotechnology Progress* 2006; 22: 1490–1506.
- [96] Miron SA, Garcia MC, Camacho GF, Molina GEY. Mixing in bubble column and airlift reactors. *Chemical Engineering Research and Design* 2004; 82 (A10): 1367–1374.
- [97] Fan L, Zhang Y, Cheng L, Zhang L, Tang D, Chen H. Optimization of carbon. 2007.
- [98] Fernandes BD, Dragoner GM, Teixeira JA, Vicente AA. Light regime characterization in an airlift. Photobioreactor for production of microalgae with high starch content. *Applied Biochemical Biotechnology* 2010; 161: 218–226.
- [99] Kommareddy AR, Anderson GA. Study of Light as a Parameter in the Growth of Algae in a Photo-Bio Reactor (PBR). ASAE Paper No. 034057. ASAE, St. Joseph, Michigan. 2003.
- [100] Zhang K, Kurano N, Miyachi S. Optimized aeration by carbon dioxide gas for microalgal production and mass transfer characterization in a vertical flat-plate photobioreactor. *Bioprocess Biosystems Bioengineering* 2002; 25: 97–101.
- [101] Scott AS, Davey MP, Dennis SJ. Biodiesel from algae: challenges and prospects. *Current Opinion in Biotechnology* 2010; 21: 277–288.
- [102] Williams JA. Keys to Bioreactor selection. *CEP Magazine* 2002; 34–41.
- [103] Becker EW. *Microalgae: Biotechnology and Microbiology*. ISBN 0521350204. 1995.
- [104] Demirel Z. Eğirdir Gölünden İzole Edilen Yeşil Mikroalg: *Chlorophyta Scenedesmus protuberans fris.* 'in Antimikrobiyal ve Antioksidan Özelliğinin Araştırılması, MSc. Thesis, Ege University, İzmir. 2006.
- [105] Molina Grima E, Belarbi E, Acie 'n Ferna 'ndez F, Robles Medina A, Chisti Y. Recovery of microalgal biomass and metabolites: process options and economics. *Biotechnology Advances* 2003; 20:491–515.
- [106] Danquah M, Ang L, Uduman N, Moheimani N, Forde G. Dewatering of microalgal culture for biodiesel production: exploring polymer flocculation and tangential flow filtration. *Journal of Chemical Technology and Biotechnology* 2009; 84:1078–83.
- [107] Popoola TOS, Yangomodu OD. Extraction, properties and utilization potentials of cassava seed oil. *Biotechnology* 2006; 5:38–41.
- [108] Serrato AG. Extraction of oil from soybeans. *Journal of the American Oil Chemistry* 1981; 58-3:157-159.

- [109] Macias-Sanchez MD, Mantell C, Rodriguez M, Martinez De La Ossa E, Lubian LM, Montero O. Supercritical fluid extraction of carotenoids and chlorophyll a from *Nannochloropsis gaditana*. *Journal of Food Engineering* 2005; 66:245–51.
- [110] Wiltshire KH, Boersma M, Moller A, Buhtz H. Extraction of pigments and fatty acids from the green alga *Scenedesmus obliquus* (*Chlorophyceae*). *Aquatic Ecology* 2000; 34:119–26.
- [111] Yusuf N, Kamarudin SK, Yaakub Z. Overview on the current trends in biodiesel production. *Energy Conversion and Management* 2011; 52: 2741–2751.
- [112] Demirbas A. Progress and recent trends in biodiesel fuels. *Energy Conversion and Management* 2009; 50: 14–34.
- [113] Lin L, Cunshan Zhou, Vittayapadung S, Xiangqian S, Mingdong D. Opportunities and challenges for biodiesel fuel. *Applied Energy* 2011; 88: 1020–1031.
- [114] Balat M, Balat H. Progress in biodiesel processing. *Applied Energy* 2010; 87: 1815–1835.
- [115] D’Elia L, Keyser A, Young C. *Algae Biodiesel, An Interactive Qualifying Project Report*. 2010.
- [116] Maa F, Hanna M. Biodiesel production: a review. *Bioresource Technology* 1999; 70: 1–15.
- [117] Sharma YC, Singh B, Upadhyay SN. Advancements in development and characterization of biodiesel: A review. *Fuel* 2008; 87(12): 2355–73.
- [118] Ahmad AL, Yasin NH, Derek JK. Microalgae as a sustainable energy source for biodiesel production: A review. *Renewable and Sustainable Energy Reviews* 2011; 15: 584–593.
- [119] Atabani AE, Silitongaa AS, Badruddina IA, Mahliaa TMI, Masjukia HH, Mekhilef S. A comprehensive review on biodiesel as an alternative energy resource and its characteristics. *Renewable and Sustainable Energy Reviews* 2012; 16: 2070–2093.
- [120] Rachmaniah O, Ju YH, Vali SR, Tjondronegoro I, Musfil AS. A study on acid-catalyzed transesterification of crude rice bran oil for biodiesel production. In: youth energy symposium, 19th World energy congress and exhibition, Sydney (Australia), September 5–9; 2004.
- [121] Xu H, Miao X, Wu Q. High quality biodiesel production from a microalga *Chlorella protothecoides* by heterotrophic growth in fermenters. *Journal of Biotechnology* 2006; 126: 499–507.
- [122] Johnson MB. *Microalgal Biodiesel Production through a Novel Attached Culture System and Conversion Parameters*. MS thesis Virginia Polytechnic Institute and State University; 2009.

- [123] Velasquez-Orta SB, Lee JGM, Harvey A. Alkaline in situ transesterification of *Chlorella vulgaris*. *Fuel* 2012; 94: 544–550.
- [124] Ferrentino JM, Farag IH, Jahnke LS. Microalgal Oil Extraction and In-situ Transesterification. Chemical Engineering, University of New Hampshire (UNH) Durham, NH <http://www.ntnu.no/users/skoge/prost/proceedings/aiche-2006/data/papers/P69332.pdf> (accessed 02.08.12).
- [125] Carvalho J, Ribiero A, Castro J, Vilarinho C, Castro F. Biodiesel Production by Microalgae and Macroalgae from North Littoral Portuguese Coast. WASTES: Solutions, Treatments and Opportunities, 1st International Conference September 12th – 14th 2011.
- [126] Tran D, Yeh K, Chen C, Chang J. Enzymatic transesterification of microalgal oil from *Chlorella vulgaris* ESP-31 for biodiesel synthesis using immobilized Burkholderia lipase. *Bioresource Technology* 2012; 108: 119–127.
- [127] Umdu ES, Tuncer M, Seker E. Transesterification of *Nannochloropsis oculata* microalga's lipid to biodiesel on Al<sub>2</sub>O<sub>3</sub> supported CaO and MgO catalysts. *Bioresource Technology* 2009; 100: 2828–2831.
- [128] Maceiras R, Rodríguez M, Cancela A, Urréjola S, Sánchez A. Macroalgae: Raw material for biodiesel production. *Applied Energy* 2011; 88: 3318–3323.
- [129] Krohn JB, McNeff VC, Yan B, Nowlan D. Production of algae-based biodiesel using the continuous catalytic Mcgyan process. *Bioresource Technology* 2011; 102: 94–100.
- [130] Özçimen D, Yücel S. Novel Methods in Biodiesel Production, In: Marco Aurélio dos Santos Bernardes (Ed. ) *Biofuel's Engineering Process Technology*. InTech; 2011. p353-384.
- [131] Patil P, Deng S, Isaac Rhodes J, Lammers PJ. Conversion of waste cooking oil to biodiesel using ferric sulfate and supercritical methanol processes. *Fuel* 2009; 89 (2): 360-364.
- [132] Patil PD, Gude VG, Mannarswamy A, Cooke P, Munson-McGee S, Nirmalakhandan N, Lammers P, Deng S. Optimization of microwave-assisted transesterification of dry algal biomass using response surface methodology. *Bioresource Technology* 2011;102: 1399-1405.
- [133] Cancela A, Maceiras R, Urrejola S, Sanchez A. Microwave-Assisted Transesterification of Macroalgae. *Energies* 2012, 5: 862-871.
- [134] Koberg M, Cohen M, Ben-Amotz A, Gedanken A. Bio-diesel production directly from the microalgae biomass of *Nannochloropsis* by microwave and ultrasound radiation. *Bioresource Technology*, 2011; 5 (102): 4265-4269.
- [135] Ehimen EA, Sun ZF, Carrington CG. Use of ultrasound and co-solvents to improve the in-situ transesterification of microalgae biomass. *Procedia Environmental Sciences* 2012; 15: 47-55.

