

The Recovery of Exhaust Heat from Gas Turbines

Roberto Carapellucci and Lorena Giordano
*Department of Mechanical, Energy and Management Engineering
University of L'Aquila
Italy*

1. Introduction

Gas turbines have established an important role in the industrial production of mechanical energy owing to the very high power-to-weight ratio achievable with simple-cycle configurations and to the high conversion efficiency that can be obtained in systems that envisage waste heat recovery from the exhaust gases.

Exhaust heat from gas turbines can be recovered externally or internally to the cycle itself [1-4]. Of the various technology options for external heat recovery, the combined gas-steam power plant is by far the most effective and commonly used worldwide. For internal heat recovery, conventional designs are based on thermodynamic regeneration and steam injection, while innovative solutions rely on humid air regeneration and steam reforming of fuel.

In this chapter different techniques for recovering the exhaust heat from gas turbines are discussed, evaluating the influence of the main operating parameters on plant performance.

A unified approach for the analysis of different exhaust heat recovery techniques is proposed. This methodology is based on relationships of general validity, in the context of interest, and on a characteristic plane for exhaust heat recovery, that indicates directly the performance obtainable with different recovery techniques, compared to a baseline non-recovery plant.

Then an innovative scheme for external heat recovery is presented: this envisages repowering existing combined cycle power plants through injection of steam produced by an additional unit consisting of a gas turbine and a heat recovery steam generator.

2. The recovery of exhaust heat

The growing popularity of gas turbines in recent years is attributable to the rapid changes in this technology, which have led to improvements in the design of both the individual components and the system as a whole. These technological advances, that concern important developments in materials, construction techniques, blades cooling, control of pollutant emissions, reliability and availability of machines, have enhanced the performance of simple cycle gas turbines, in terms of electrical efficiency and unit size. They have also led

to a significant increase in temperature and flow rates at the gas turbine exit, thus the need for efficient exhaust heat recovery systems.

The waste heat exhausted from gas turbines can be recovered externally or internally to the cycle itself. External heat recovery can be achieved using a bottoming steam power plant (combined cycle). Internal heat recovery involves reusing the thermal energy exiting the turbine, by means of conventional (thermodynamic regeneration and steam injection) or unconventional techniques (humid air regeneration, steam fuel reforming) [5].

In this paragraph the different recovery techniques will be discussed, highlighting for each of them the main thermodynamic and economic features.

2.1 Combined gas-steam cycle power plants

A combined cycle gas turbine (CCGT) is a fossil fuel power plant that combines the Brayton cycle of the gas turbine with the Rankine cycle of the steam turbine. In a typical layout, shown in Figure 1, exhaust heat from the gas turbine, passing through a heat recovery steam generator (HRSG), produces steam that evolves in the bottoming steam cycle. This type of recovery is said to be "direct", because the heat is transferred directly to the working fluid of another system. In order to improve heat recovery in the HRSG, more than one pressure level is generally required. Combined-cycle configurations, with a triple pressure heat recovery steam generator and steam reheat, attain thermal efficiency of more than 55%.

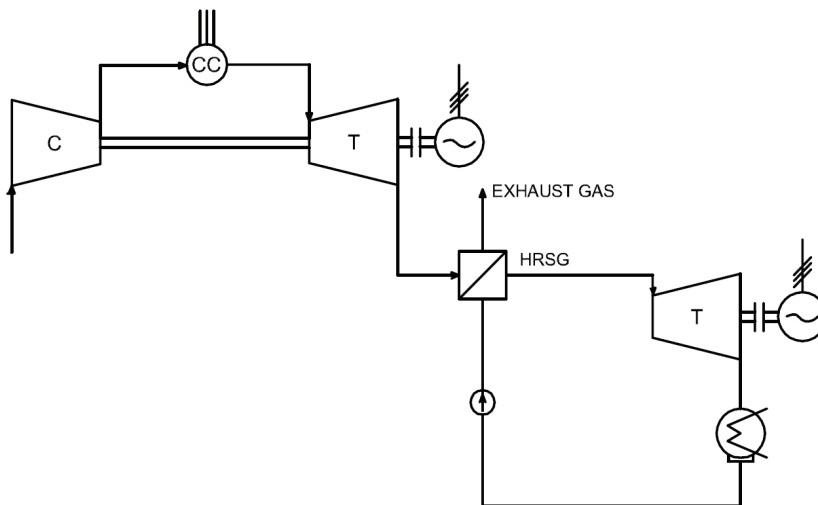

Fig. 1. Schematic diagram of CCGT cycle

In addition to high efficiencies, combined cycle plants have many other advantages, including [6]:

- low emissions, since natural gas produces no ash or SO_x and smaller quantities of volatile hydrocarbons, CO and NO_x than oil and coal;
- low capital costs and short construction times (often 2–3 years);

- smaller space requirements than equivalent coal or nuclear power plants;
- flexibility in plant size, ranging from 10 to 750 MWe per combined cycle-unit;
- fast start-up, making it easier to respond to changes in demand.

Recent years have seen a significant increase in the use of combined cycle power plants that, despite the higher fuel cost compared to conventional steam power plants, are currently the best choice in terms of cost per unit of electricity [7].

These plants had already become quite popular in the Italian cogeneration sector. Since the mid 1990s, as shown in Figure 2, installed capacity has grown considerably, bringing the number of sections from 57 (1996) to 131 (2008).

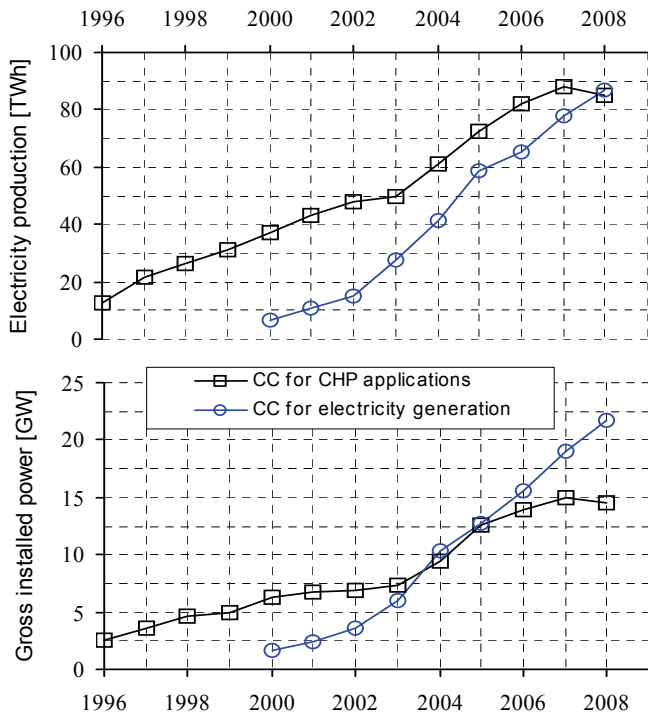

Fig. 2. Combined cycle plants for electric power production and cogeneration in Italy [8]

But since 2000 these plants have found application in the generation of electric power alone, with the installation of 5 sections, increasing to 53 in 2008, with a total installed capacity of around 22000 MW. These systems are characterized by very high efficiency, on average more than 54% [8]. This trend is likely to continue in the future, as shown by the planning permissions granted from 2002 to April 2010, for the construction of new power plants in Italy (Table 1). Indeed, nearly all the plants have efficiencies of above 50%, testifying to the advantages of adopting combined cycle plants.

COMPANY	PLANT LOCATION	MWe	MWt	MWe/MWt
EDISON	MARGHERA	environmental remediation		
	TORVISCOSA	800	1500	53.3%
	ORTA DI ATELLA	780	1340	58.2%
	ALTOMONTE	800	1400	57.1%
	SIMERI CRICHI	800	1360	58.8%
	PIANOPOLI	800	1360	58.8%
	CANDELA	360	650	55.4%
	Total	4340	7610	57.0%
ENIPOWER	FERRERA ERBOGNONE	1040	1850	56.2%
	MANTOVA	780	1370	56.9%
	RAVENNA	785	1370	57.3%
	BRINDISI	1170	2200	53.2%
	FERRARA	800	1400	57.1%
		Total	4575	8190
ENEL PRODUZIONE	CASTEL SAN GIOVANNI	80	120	66.7%
	LIVORNO	environmental adaptation		
	CAVRIGLIA/SANTA BARBARA	390	700	55.7%
	CIVITAVECCHIA	fuel change		
EDIPOWER	TURBIGO	repowering		
	PIACENZA	58 MWe for summer peak load		
ENDESA ITALIA	TAVAZZANO	conversion to combined cycle		
	FIUME SANTO	80	220	36.4%
ABRUZZOENERGIA	GISSI	760	1400	54.3%
ACEAELECTRABEL PRODUZIONE	LEINI'	380	700	54.3%
AEM MI -ASM BS	CASSANO D'ADDA	390	700	55.7%
AEM TORINO	MONCALIERI	770	1350	57.0%
ASM BS e AMGS VR	PONTI SUL MINCIO	250	450	55.6%
CALENIA ENERGIA	SPARANISE	800	1400	57.1%
E.ON ITALIA PRODUZIONE	LIVORNO FERRARIS	800	1400	57.1%
ELECTRABEL ITALIA	ROSIGNANO SOLVAY	400	750	53.3%
EN PLUS	SAN SEVERO	390	700	55.7%
ENERGIA	BERTONICO/TURANO	800	1400	57.1%
	LODIGIANO			
ENERGIA MODUGNO	MODUGNO	750	1350	55.6%
ENERGIA MOLISE	TERMOLI	750	1300	57.7%
ENERGY PLUS	SALERNO	780	1370	56.9%
EUROSVILUPPO ELETTRICA	SCANDALE	800	1390	57.6%
IRIDE ENERGIA	TORINO NORD	400	710	56.3%
ITALGEN	VILLA DI SERIO	190	365	52.1%
MIRANT GENERATION PORTOGRUARO	PORTOGRUARO	planning permission expired		
RIZZICONI ENERGIA	RIZZICONI	800	1400	57.1%
SARMATO ENERGIA	SARMATO	47	70	67.1%
SET	TEVEROLA	400	750	53.3%
SORGENIA	APRILIA	750	1350	55.6%
TERMICA CELANO	CELANO	70	100	70.0%
TIRRENO POWER	VADO LIGURE	conversion to combined cycle		
TIRRENO POWER	NAPOLI LEVANTE	400	700	57.1%
VOGHERA ENERGIA	VOGHERA	400	750	53.3%
	Total	21800	38695	56.3%

Table 1. Planning permissions for power plants in Italy, granted from 2002 to April 2010 [9]

2.2 Gas turbine configurations with internal heat recovery

Compared to simple cycle gas turbines, the higher costs of constructing a combined cycle plant are not always offset by higher efficiency, especially for small and medium size plants. The need to combine the high efficiency of combined cycles with the low cost of simple cycles has raised the interest in new technologies that enable internal waste heat recovery from the gas turbine.

Internal heat can be recovered through the working fluid (fuel, air) or an auxiliary fluid (usually water). In the first case internal heat recovery is defined as "direct", in the second as "indirect"[5].

Thermodynamic regeneration is a direct internal recovery technique, since thermal energy is transferred directly from exhaust gas to air at the compressor exit. This produces an efficiency gain due to the reduction in primary thermal energy requirements without changing, as a first approximation, the mechanical power output.

Steam injection on the other hand is an indirect internal recovery technique. In this case the recovered thermal energy is transferred to an auxiliary fluid (water), which is then injected into the combustor. This increases the primary thermal energy required to keep the temperature at the turbine inlet constant, but results in a power increase and, consequently, an efficiency gain.

Direct and indirect recovery can also be combined, as for instance in HAT and CRGT cycles. In humid air plants (HAT), the saturation of air at compressor exit extends the regeneration margins, thanks to the greater temperature difference between the exhaust gas at turbine exit and the compressed air at regenerator inlet. In chemically recuperated plants (CRGT), exhaust heat is recovered through an endothermic steam-reforming process of the primary fuel. More specifically, a portion of the recovered heat is transferred directly to the fuel, while the remainder is used to produce the required steam.

2.2.1 Heat recovery without auxiliary fluid

In thermodynamic regeneration, the exhaust heat at the turbine exit is used to preheat the air entering the combustion chamber. The heat exchange between the two gas streams is achieved by means of a countercurrent heat exchanger, known as a regenerator or recuperator. Figure 3 shows a schematic diagram of the regenerative cycle.

The thermal efficiency of the Brayton cycle is enhanced since regeneration decreases the heat input required to produce the same net work output. Heat recovery through a gas-to-gas heat exchanger is limited by a characteristic value of the compression ratio, beyond which the temperature of the exhaust gas falls below that of the air at the compressor outlet, thereby deteriorating efficiency.

The efficiency gain achieved through regeneration strongly depends on the heat exchanger effectiveness, defined as the ratio of the actual heat transfer rate to the air and the maximum possible heat transfer rate, that would exist were the heat exchanger to have infinite heat transfer surface area. More specifically, gas turbine efficiency increases with heat exchanger effectiveness, as the air at the combustion chamber inlet is preheated at higher temperatures, resulting in greater fuel savings.

However, to achieve greater effectiveness requires a larger heat transfer area. This translates into higher capital costs and larger pressure drops on both air and gas sides of the heat exchanger, which reduce the turbine pressure ratio and therefore the turbine work.

Generally, the air pressure drop on the high-pressure side should be kept below 2% of the total compressor discharge pressure. The effectiveness of most regenerators used in practice is below 0.85.

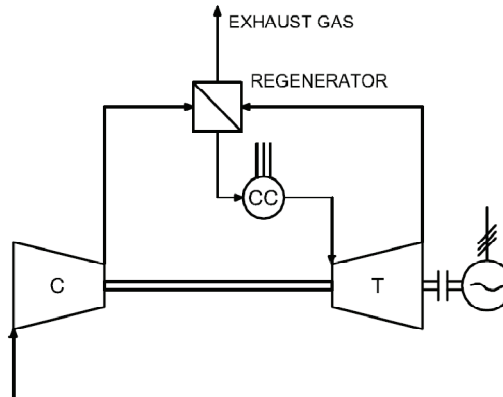

Fig. 3. Schematic diagram of the regenerative cycle

The regenerator takes up a very large area because of the low heat transfer coefficients of air and exhaust gases. This results in high costs and loss of compactness, affecting the main features of gas turbines. In addition, the exhaust gas flow in the regenerator leads to the formation of carbon deposits, resulting in a reduction of heat transfer coefficient, which becomes more pronounced over time.

The regenerator has met with little success in the industrial gas turbines sector, because of the low efficiency gain accompanied by the significantly higher capital costs.

Only in recent years this option has started to make a comeback, as it can be advantageously integrated with other technologies, such as steam injection.

Moreover regeneration is successfully applied in micro - gas turbines, where the low compression ratios are related to the simplicity of turbomachines.

2.2.2 Heat recovery through steam generation

In the steam injection cycle (STIG), proposed by Cheng in 1978 [10], the gases exhausting the turbine are used to produce steam in a heat recovery steam generator, that is then injected into the combustion chamber (Figure 4).

In addition to drastically reducing the formation of nitrogen oxides, steam injection increases both efficiency and power output [11]. The efficiency gain is about 10%, lower than that obtained with a conventional combined cycle, because the steam expands in a less efficient manner in the gas turbine than in the steam turbine. On the other hand, the power increase varies between 50 and 70% [12].

The steam pressure should be sufficient to enable injection into the combustor. Typical values of this parameter range from 1.25 to 1.4 times the maximum pressure of the cycle. In addition, the water used for steam production must be demineralized to minimise salts and oxides content so as to prevent fouling the turbomachinery or chemical attack at high temperatures.

A practical concern with steam injection is water consumption, that typically ranges from 1.1 to 1.6 kg of high purity water per kWh of electrical output. The water purification system required for large scale plant would represent about 5% of total capital costs, whereas running costs add about 5% to the fuel cost [12].

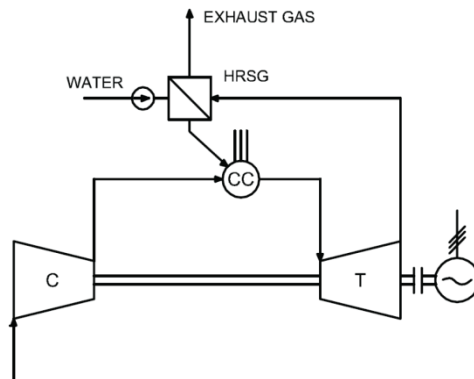

Fig. 4. Schematic diagram of STIG cycle

As the temperature of injected steam must be raised to combustion chamber temperature, a small temperature difference at the approach point (i.e. at boiler outlet) can be advantageous. However, since the evaporation process takes place at constant temperature, high steam temperatures are necessarily accompanied by low heat recovery.

Since the high steam temperature requirements conflict with large heat recoveries, there is a limit to the maximum attainable efficiency with STIG cycles.

Efficiency can be improved using multi-pressure systems whereby the water vapour temperature profile matches that of the exhaust gases more closely, resulting in a better approximation to a reversible process [1]. However, this complicates the design, while plant simplicity is one of the strengths of this technology.

As shown in Figure 5, humid air turbines (HAT) combine regeneration and steam injection. Compared to a traditional regenerative gas turbine, HAT cycle requires the addition of a surface heat exchanger and a saturator. The air at the compressor outlet passes through the heat exchanger, where liquid water is preheated; then air passes through the saturator, where it mixes with the steam, undergoing at the same time a reduction in temperature, as water evaporation absorbs latent heat from the gas stream. The saturation of air at compressor exit extends the regeneration margins, thanks to the greater temperature difference between the exhaust gas exiting the turbine and the compressed air at the regenerator inlet. Moreover humidification reduces the heat capacity difference between air and exhaust gas, resulting in increased efficiency of the regenerator heat recovery [2].

HAT cycles overcome the intrinsic limits of steam injection, further enhancing efficiency.

The main issue of humid air turbines is the difficulty in containing the pressure drops related to the compressed moist air flow through the saturator and the regenerator. The saturator can operate with any clean and filtered water source, as long as the dissolved substances at the water outlet remain below their precipitation concentration under operating conditions [13]. Water consumption is a problem as for steam injection cycles but the consumption rate is only about one third [1].

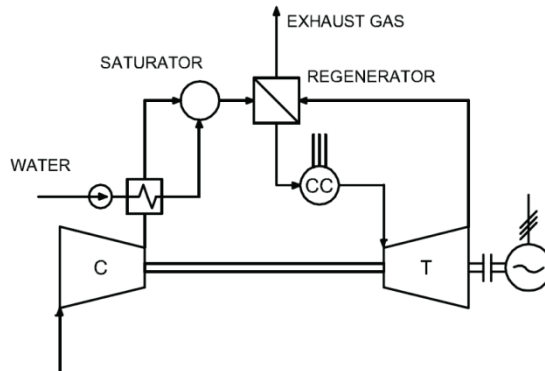

Fig. 5. Schematic diagram of HAT cycle

The chemically recuperated gas turbine (CRGT) is an extension of the steam-injected gas turbine concept [14]. As shown in Fig. 6, the thermal energy available in the exhaust gases is used to promote an endothermic reaction in the primary fuel, that can occur with or without water addition. In the first case the process is called steam reforming, whereas in the second simple decomposition. The process requires the presence of a nickel based catalyst and results in the production of a reformed fuel, composed of CO, CO₂, H₂, excess steam and unconverted fuel, which is fed directly to the combustion chamber.

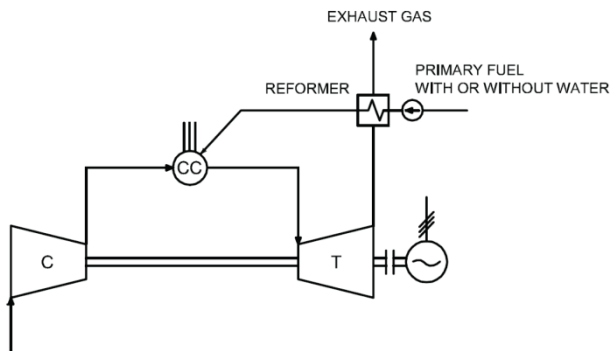

Fig. 6. Schematic diagram of CRGT cycle

The reformed fuel absorbs heat thermally and chemically, resulting in a potentially greater recovery of waste heat than conventional recovery techniques [14]. In fact the thermal

energy recovered at a relatively low temperature is made available at a higher temperature, during oxidation of the reformed fuel.

Moreover CRGT cycles have ultra low NOx emissions, due to the large amount of steam contained in the reformed fuel, lowering the temperature in the primary zone of the combustor.

Recently there has been a revived interest in this technology, in view of the potential use of strategic fuels, such as methanol.

3. A unified thermodynamic approach

The different waste heat recovery techniques can be analysed using a unified thermodynamic approach. Heat recovery influences gas turbine performance by means of two concurrent effects. The first is related to the variation of primary thermal energy (ΔQ_1) supplied from the outside, the second to the increase in power (ΔP) produced by the auxiliary fluid, where present.

3.1 Equations for exhaust heat recovery

Denoting with η overall plant efficiency, we can write

$$\frac{\eta}{\eta^*} = \frac{1 + \Delta P / P^*}{1 + \Delta Q_1 / Q_1^*} \quad (1)$$

where η^* , P^* and Q_1^* refer to the non-recovery baseline plant.

Neglecting water pumping power and pressure losses of heat recovery devices, the term ΔP is only related to the auxiliary fluid expanding through the gas turbine. The term ΔQ_1 generally comprises two contributions

$$\Delta Q_1 = \Delta Q_{1,AF} - \Delta Q_{1,DR} \quad (2)$$

The first term $\Delta Q_{1,AF}$ is the additional primary thermal energy required to attain the maximum cycle temperature when an auxiliary fluid is introduced. The second term $\Delta Q_{1,DR}$ refers to the heat reintroduced into the cycle, on the air or fuel side, through direct recovery.

Equation (1) can be taken as a basic relation for characterizing the capabilities of internal and external heat recovery of gas turbines.

For direct external heat recovery, i.e. in the case of combined gas-steam cycles, the term ΔP refers to the steam turbine power output and ΔQ_1 is positive only when supplementary firing is performed.

For direct internal heat recovery, such as thermodynamic regeneration or dry chemical recovery, the power remains practically unchanged ($\Delta P=0$) and the term $\Delta Q_{1,AF}$ is nil. Therefore the efficiency increase is only due to the reduction in the primary thermal energy supplied ($\Delta Q_1 = -\Delta Q_{1,DR} < 0$). For thermodynamic regeneration $\Delta Q_{1,DR}$ can be immediately interpreted; for dry chemical recovery it represents the energy required by the endothermic decomposition process, recovered from the exhaust gases and transferred to the reformed fuel, by increasing the heating value.

For indirect internal heat recovery, such as steam injection, the introduction of an auxiliary fluid increases power output ($\Delta P > 0$) and primary thermal energy ($\Delta Q_I = \Delta Q_{I,AF} > 0$). Efficiency increases only if

$$\eta_{FA} = \frac{\Delta P}{\Delta Q_{I,AF}} > \eta^* \quad (3)$$

where the term on the left hand side can be interpreted as the marginal efficiency of the auxiliary fluid. State of the art gas turbine technology satisfies this condition for steam injection, even for low degrees of superheat, but not for water injection, that produces a power increase with an efficiency penalty.

In the case of combined (direct-indirect) internal heat recovery, such as humid air regeneration or steam reforming, efficiency increases as a result of two effects. The first refers to the power output increase (ΔP), the second to the primary energy variation (ΔQ_I), that can be negative or positive in accordance with Eq. (2). Since ΔP and $\Delta Q_{I,AF}$ are proportional to the mass flow rate of the auxiliary fluid, for a given value thereof, the efficiency gains are greater the more $\Delta Q_{I,DR}$ increases.

3.2 A performance plane for exhaust heat recovery

Using Eq. (1) it is possible to define a characteristic plane, that allows to compare different techniques for recovering exhaust heat from gas turbines, highlighting their application limits.

As shown in Figure 7, the performance plane of waste heat recovery indicates the trend of the ratio η/η^* as a function of $\chi = \Delta Q_I/Q_I^*$ and $\pi = \Delta P/P^*$. The relation between η/η^* , χ and π does not depend on gas turbine characteristics, which are instead introduced by two other families of curves. These define the conditions for constant values of the direct recovery parameter, defined as $\xi = \Delta Q_{I,DR}/Q_I^*$, and for those of the non-dimensional flue gas temperature, defined as $\tau = T_{FG}/T_{FG}^*$ [5]. From Eqs. (2) and (3), we can derive a relationship among different non-dimensional parameters of internal heat recovery

$$\chi = \pi \left(\eta^* / \eta_{AF} \right) - \xi \quad (4)$$

This establishes, for a given gas turbine (η^*) and recovery technique (ξ and η_{AF}), the relationship between χ and π .

For $\pi=0$ - simple direct recovery - from Eq. (4) we get $\chi = -\xi$; therefore, each point on $\pi=0$ curve of Fig. 11 is characterized by a different ξ value.

Each point P on this curve defines an envelope of curves at constant ξ , but characterized by different η_{AF} values. Combining Eqs. (1) and (4), we get

$$\left. \frac{\partial(\eta/\eta^*)}{\partial\chi} \right|_{\xi=\text{const}} = \frac{1}{(1+\chi)^2} \left[\frac{\eta_{AF}(1-\xi)}{\eta^*} - 1 \right] \quad (5)$$

Equation (5) defines the slope of curves with constant ξ , at each value of η_{AF} related to the thermodynamic conditions of auxiliary fluid at the combustor inlet.

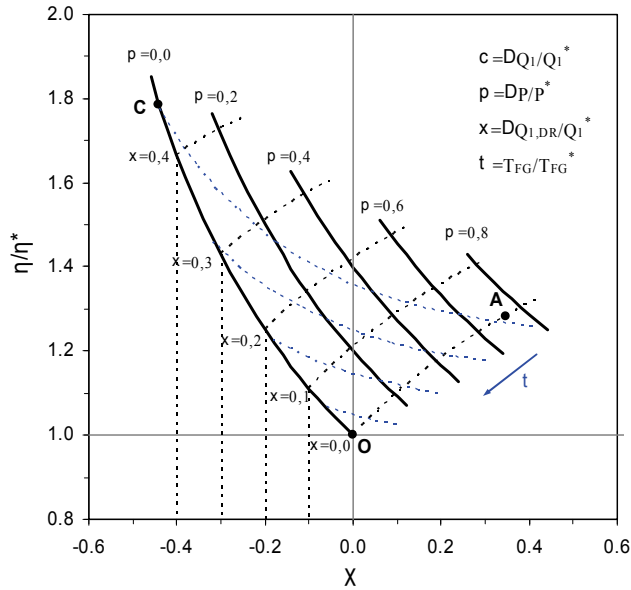

Fig. 7. A performance plane for exhaust heat recovery

The curve with the maximum slope (i.e. maximum η_{AF} value) is obtained at the maximum auxiliary fluid temperature, that occurs, in the case of steam injection, inside the combustor at the maximum degree of superheat permitted by the steam generator, as well as for steam reforming at the maximum temperature allowable by the exhaust gas at the turbine exit.

Decreasing η_{AF} , that is for a lower enthalpy of the auxiliary fluid introduced into the combustor, the slope of curves at constant ξ diminishes eventually becoming negative in the case of water injection.

Figure 8(a), for instance, shows two η_{AF} curves for steam injected at the maximum degree of superheat ($\eta_{AF,1}$) and under saturated conditions ($\eta_{AF,2}$). For a given plant with no heat recovery (P^*, η^*), a generic point Q on the characteristic plane, as shown in Figure 8(b), may represent different internal heat recovery techniques characterized by various combinations of direct and indirect recovery ($\xi_1 < \xi_2$ and $\eta_{AF,1} > \eta_{AF,2}$), based on plant configurations defined by different value of ξ and η_{AF} .

The constant τ curves indicate the extent of the recovery. For a fixed value of τ , the maximum efficiency increase is obtained for $\pi=0$. Instead, when an auxiliary fluid is introduced, at constant τ , the efficiency increase is lower due to the unrecoverable latent heat of steam at the turbine exit.

Assuming a limit value for the flue gas temperature, the corresponding curve, together with the curves at $\pi=0$ and $\xi=0$ define a characteristic region (OAC in Fig. 7) which represents the possible recovery conditions. Each point inside this region does not represent a specific

plant configuration, since the same performance can be obtained with different heat recovery techniques.

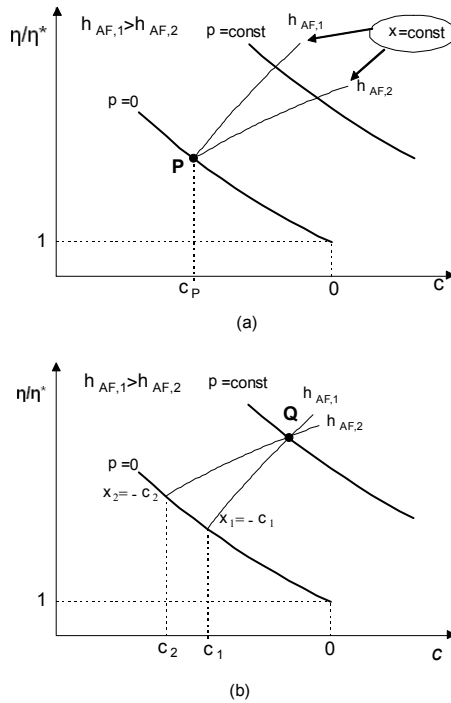

Fig. 8. Influence of marginal auxiliary fluid efficiency on combined recovery capabilities

Points on the curve $\pi=0$ (curve OC in Fig. 7) therefore indicate plant configurations with direct recovery ($\chi=-\xi$) alone, those on the curve OA ($\xi=0$) on the contrary, solutions with indirect recovery ($\chi=\pi \eta^*/\eta_{AF}$) alone and are characterized by positive values of χ denoting an increase of primary energy supplied to the cycle.

The plane region above curves OC and OA represents conditions for combined direct and indirect recovery. Negative values of χ , denoting a net reduction of primary energy to the cycle, are possible if direct recovery effects predominate over those associated with steam injection. One limitation to the extension of the OAC region is the minimum flue gas temperature attainable inside the stack, also taking into account the characteristics of the single internal heat recovery techniques (regenerator effectiveness, saturation conditions, pinch point at HRSG, steam-to-methane ratio at reformer). A further restriction may also arise from operational problems with existing combustor and turbomachinery, especially if high steam flow rates are injected [5].

4. Capabilities of exhaust heat recovery techniques

The characteristic plane of heat recovery can be used to determine the capabilities of different internal and external heat recovery techniques for a variety of gas turbines.

Having defined the non-recovery gas turbine, the construction of this plane requires the evaluation of performance increases achieved by different heat recovery configurations compared to the baseline gas turbine. For this purpose the General Electric software GateCycle has been used [15]. Using this modelling tool specific plant configurations have been developed to simulate the non-recovery baseline simple cycle (SC), the regenerative cycle (RG), the steam injected cycle (SI), the regenerative steam injected cycle (RG+SI), the humid air regenerative cycle (HAT) and the chemically recuperated cycle (CRGT). In all cases with exhaust heat recovery, combustor and turbomachinery design data are taken to be the same as for the corresponding simple non-recovery cycle, while operating data for each heat recovery device have been examined over significant ranges.

In order to evaluate the influence of pressure ratio and turbine inlet temperature on capabilities of different recovery techniques, the characteristic plane of heat recovery has been defined with reference to four non-recovery gas turbines, that differ in terms of pressure ratios and turbine inlet temperatures.

Referring to these characteristic planes, represented in Figure 9, the different internal and external heat recovery techniques will be discussed in more detail in the following subsections, highlighting the influence of pressure ratio and temperature inlet temperature on efficiency increase.

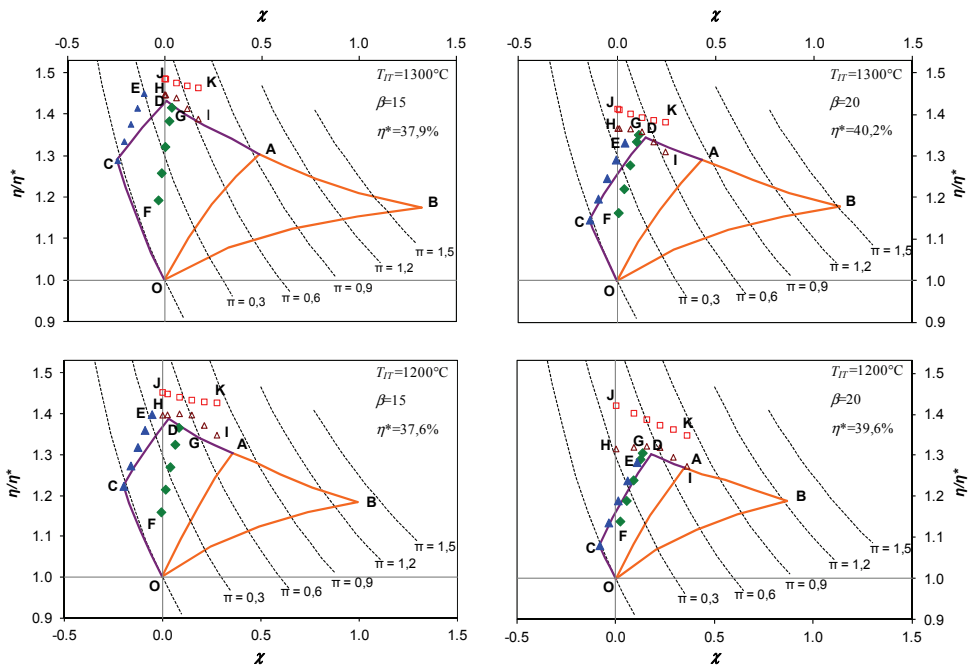

Fig. 9. Characteristic plane of heat recovery for different non-recovery gas turbines (Internal heat recovery - OC : Thermodynamic regeneration, OAB: Steam injection, CD: Regeneration with steam injection, CE: Humid air regeneration (HAT), FG: Steam methane reforming. External heat recovery - HI: Combined cycle with one pressure level HRSG, HI: Combined cycle with three pressure levels HRSG and reheat.)

4.1 Direct external heat recovery

Curves HI and JK represent the performance obtained for external heat recovery through a bottoming steam cycle (combined cycle). In particular, the curve HI refers to the case of a combined cycle with one pressure level at the HRSG, whereas curve JK to a combined cycle with three pressure levels and reheat. Points H and J correspond to the case of combined cycle without supplementary firing, the primary energy supplied from outside ($\chi = 0$) remaining the same. Points I and K correspond instead to the case of supplementary firing using exhaust gases exiting the turbine and setting the limit temperature at the duct burner exit to 800 °C.

Without supplementary firing, the combined cycle with three pressure levels HRSG and reheat (point J) is the leading solution in power generation, providing efficiencies of 54.6%-56.8% in the explored range of β and T_{IT} , higher by 2-3 percentage points than those obtained with one pressure level HRSG (point H). With supplementary firing, the further power increase is obtained at the expense of efficiency (I and K). Only in the case of one pressure level HRSG, with modest additional combustion and low values of T_{IT} , a slight improvement in performance is achieved, as a result of the greater recovery feasible at low temperatures.

4.2 Direct internal heat recovery

Direct internal heat recovery, achieved by transferring thermal energy from the gas turbine exhaust to the compressed air upstream from the combustor, is represented by curve OC on the characteristic plane.

At point O the temperature difference on the hot side of the regenerator (ΔT_{RG}) is zero. Since there is no heat exchange between exhaust gas and air at the compressor exit, gas turbine efficiency coincides with the baseline simple cycle with no heat recovery. Moving along the curve OC the temperature difference increases, as well as regenerator effectiveness and gas turbine efficiency, reaching a maximum value at point C, corresponding to a temperature difference of 40 °C.

Neglecting pressure losses, point C shows a slight power derating with respect to the reference plant (point O) due to the smaller amount of primary fuel introduced into the combustor.

To evaluate the influence of pressure ratio and the turbine inlet temperature on efficiency increase through thermodynamic regeneration, it suffices to compare the OC curve of the different baseline non-recovery gas turbines. As shown in Figure 9, efficiency gain is maximised at low pressure ratios and high turbine inlet temperatures. Focusing the attention on point C, we see that direct recovery parameter ($\xi = -\chi$) increases from 0.08 at low maximum gas temperature ($T_{IT}=1200^\circ\text{C}$) and high pressure ratio ($\beta=20$) up to 0.24 at $T_{IT}=1300^\circ\text{C}$ and $\beta=15$. Consequently, the efficiency ratio η/η^* passes from 1.08 to 1.29, the efficiency η of the regenerative cycle from 42.9% to 48.9% and the flue gas temperature T_{FG} from 470°C to 420°C.

4.3 Indirect internal heat recovery

The points inside the region OAB (Fig. 9) represent performance achievable with waste heat recovery performed by steam injection upstream from the combustion chamber. This region

is bounded by two curves at $\xi=0$ (OA and OB) and by the curve AB corresponding to the minimum temperature difference at pinch point of the heat recovery steam generator ($\Delta T_{pp}=10^\circ\text{C}$). As mentioned above, the slope of the curve with $\xi=0$ depends on the gas turbine plant with no heat recovery, η^* and on marginal efficiency η_{AF} .

In particular the curve OA refers to the case of maximum marginal efficiency η_{AF} obtained by injecting steam superheated to the same temperature as the turbine exhaust, while curve OB refers to the case of minimum η_{AF} , corresponding to injection of saturated steam. The entire region can be covered varying the hot side temperature difference in the superheater and the minimum temperature difference in the evaporator.

Efficiency gains due to steam injection diminish with steam temperature, while both steam mass flow rate and power produced increase. In practice the power increase is limited by problems associated with the large water requirements and compressor-turbine matching.

To evaluate the influence of β and T_{TI} on steam injection capabilities, points A and B are examined. In both cases, steam mass flow rate as well as power increase with temperature, while the opposite trend is observed when pressure ratio is increased.

In particular, at point A (superheated steam) the mass flow rate increase passes from a minimum of 20% at low maximum gas temperature ($T_{TI}=1200^\circ\text{C}$) and high pressure ratio ($\beta=20$) to 30% at $T_{TI}=1300^\circ\text{C}$ and $\beta=15$. On the other hand, at point B (saturated steam) the mass flow rate increase ranges from 34 to 55%, under the same pressure and turbine inlet temperature conditions.

4.4 Combined internal heat recovery

Performances associated with points inside the region OCDA (Fig. 9) can only be obtained considering recovery techniques that combine direct (thermodynamic regeneration) and indirect recovery (steam injection). The effects associated with the auxiliary fluid occur in different ways, with regard to marginal efficiency value (η_{AF}), which depends on the thermodynamic conditions of the auxiliary fluid upstream from the combustion chamber.

The region OCDA can be covered varying the hot side temperature difference in the regenerator and the minimum temperature difference in the evaporator.

Heat can also be indirectly recovered using unconventional techniques, such as humid air regeneration and steam reforming of the fuel.

The performance of HAT plants is represented by the points on curve CE. Keeping the hot side temperature difference in the regenerator at 40°C , curve CE has been obtained increasing the mass of water introduced into the saturator from zero (point C) to the maximum permissible value for saturation of the compressed air upstream from the regenerator (point E). On this curve the value of ξ , defined at point C, remains constant, since this parameter is established by the capabilities of the plant with no heat recovery with respect to thermodynamic regeneration.

Gas turbine plants with chemical recovery are represented on curve FG, where methane is used as primary fuel. The methane reforming process is described by the following two reactions:



The reforming reaction (Eq. (6)) is highly endothermic and is favoured by higher temperatures, lower pressures and higher steam-to-methane mole ratios. The water gas shift reaction (Eq. (7)), slightly exothermic, favours lower temperatures and is unaffected by pressure [16].

Keeping the hot side temperature difference in the reformer at 40°C, curve FG refers to steam reforming performed varying the steam-to-methane mole ratio from the stoichiometric value $n=2$ (point F) to the maximum value corresponding to the minimum pinch point temperature difference (point G).

Curve FG is characterized by a steep slope, for increasing values of ξ . In fact, the thermal energy directly recovered, denoted with ξ , is the chemical energy variation associated with the reforming process that increases with steam-to-methane mole ratio (n).

The influence of β and T_{TI} on combined internal heat recovery capabilities are discussed focusing the attention on points representing maximum heat recovery conditions for each solution: point D for regenerative steam injected cycle, point E for humid air regenerative cycle, point G for chemically recuperated cycle.

For regenerative steam injected cycle (point D) at high turbine inlet temperature ($T_{TI}=1300^\circ\text{C}$) and low pressure ratio ($\beta=15$), direct and indirect recovery have comparable effects on χ ; therefore primary fuel energy introduced into the cycle remains practically unchanged, while efficiency exceeds 54.3%, due to the significant power increase ($\pi=0.45$). On the contrary, at $T_{TI}=1200^\circ\text{C}$ and $\beta=20$, effects of indirect recovery prevail, producing a higher power increase ($\pi=0.54$) and a lower efficiency gain ($\eta/\eta^*=1.3$).

For humid air regenerative cycle (point E), efficiency gains achievable are higher than the regenerative steam injected cycle (point D), particularly at high maximum gas temperature and low pressure ratio. At $T_{TI}=1300^\circ\text{C}$ and $\beta=15$, HAT plants attain efficiencies of up to 55%, limiting the relative mass flow rate increase in the turbine to 10%.

In the case of the chemically recuperated cycle (point G), since steam methane reforming reactions prefer low pressure and high temperature, the greatest efficiency gains are obtained at high turbine inlet temperature and low pressure ratio. At $T_{TI}=1300^\circ\text{C}$ and $\beta=15$, methane conversion ratio is close to 55% and, consequently, efficiency increases up to 53.8%.

4.5 Limits of indirect internal heat recovery

Steam injection in a gas turbine is affected by operational constraints related to compressor-turbine matching, defined on the basis of the characteristic curves of turbomachines. Figure 10 shows a typical axial compressor map, bounded above by the surge line and below by the choke line. Operation limits in the surge region are due to an increase in the angle of incidence between the fluid and the compressor blades, produced by a decrease in fluid flow rate or an increase in rotational speed. Any excessive increase of the angle of incidence may cause fluid separation and flow reversal, generally accompanied by strong noise and violent vibrations which can severely damage the machinery. In order to avoid this

instability phenomenon, the axial compressor operates in nominal conditions, with a certain margin from the surge region.

However, when steam injection occurs, both the mass flow rate and the turbine inlet pressure increases. The compressor follows the turbine behaviour by increasing the compression ratio and, consequently, approaching the surge line.

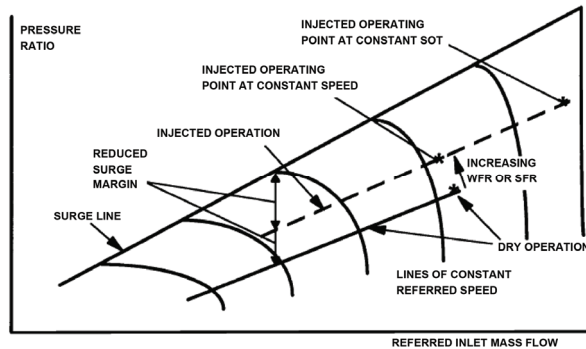

Fig. 10. Gas turbine operating line in dry and wet conditions [17]

Therefore the injection rate must be regulated to keep the pressure ratio below the surge line. In practice, for existing gas turbines, injected steam flow rate is limited to 10% of the compressor inlet air flow [18].

Moreover, the water introduced into the gas turbine may create problems associated with availability and treatment and with the mass flow rate increase through the expander.

In the presence of low-temperature heat users, the exhaust gases could be cooled down to 50 °C, in order to achieve partial water condensation.

The water can be condensed in an indirect surface heat exchanger, that uses water or ambient air to cool the exhaust gas or in a direct-contact condenser, where water is sprayed into the exhaust gas [2].

Large amounts of water are required for partially condensing steam, so these power plants should be located near to water sources (sea, lakes, rivers). In cases of low water availability, "closed loop" refrigeration is conducted, sending the water at the condenser outlet to a cooling tower.

4.5.1 Effect of limits on the characteristic plane of heat recovery

To ensure proper operation of the gas turbine, the limit on maximum flow rate increase at the turbine inlet, results in a reduction of the maximum performance achievable by the different internal heat recovery techniques.

In this regard, Figure 11 shows the characteristic plane of heat recovery for a baseline gas turbine $T_{IT} = 1300^{\circ}\text{C}$ and $\beta=15$. In this plane, the dash-dot line curve refers to an increase in mass flow rate at the turbine inlet of 10%. As shown in Figure 11, the performance region for steam injection is significantly reduced, passing from OAB to OA'B'; similarly the region

related to combined recovery (obtained by means of thermodynamic regeneration and steam injection) is reduced from OCDA to OCD'A'.

Indirect external heat recovery

The issue of limiting the maximum flow rate increase at the turbine inlet can be overcome by carrying out indirect external heat recovery, represented by curve OL in Figure 11. This recovery option, which will be discussed in detail in the following paragraph, is achieved by injecting superheated steam produced in the combustion chamber of an existing combined system. The existing combined cycle has a three pressure levels HRSG, with characteristics similar to those indicated in the following paragraph. Efficiencies defined by curve OL are assessed in marginal terms, i.e. appropriately taking into account only primary energy and power output increases attributable to the steam injected into the combustion chamber.

The curve OL shows the typical trend of internal recovery through steam injection (curve OA'). However, this recovery option is not affected by limits on the maximum steam flow rate, the gas turbine being appropriately sized for integration with the existing combined cycle, in order to keep steam injection flow rates below 10% of the air flow at the compressor inlet.

Moreover, it is interesting to note that the slope of curve OL is greater than curve OA, due to the improved performance of the combined cycle compared to the simple gas turbine. This allows to better exploit the injected steam, leading to higher efficiency gains.

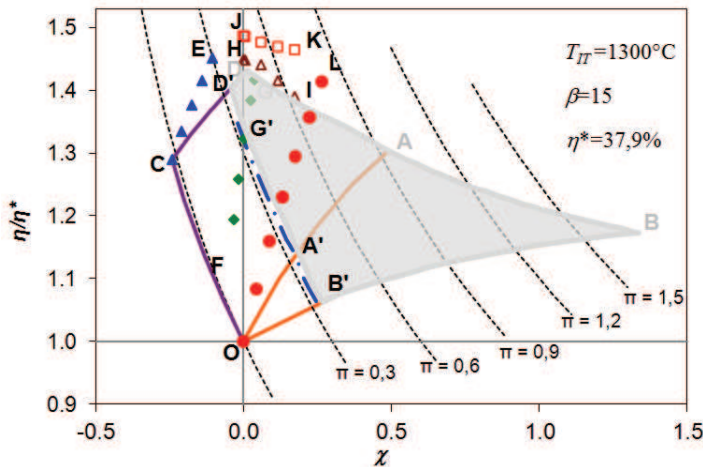

Fig. 11. Characteristic plane of heat recovery restricted by limiting the maximum injected steam flow rate to 10% of the compressor inlet air flow (OL: Steam injection within an existing combined cycle)

5. Repowering of combined cycle power plants through steam injection

The analysis carried out by means of the characteristic plane of heat recovery has shown that steam injection cannot compete with combined heat recovery techniques, such as humid air regeneration or fuel steam reforming.

However, steam injection can be seen as the only indirect recovery technique introducing an innovative scheme, whereby steam injection is not used as a means of traditional internal heat recovery, reintroducing steam into the gas turbine combustion chamber. On the contrary heat is recovered externally, generating steam for repowering an existing combined cycle.

5.1 Description of the repowering scheme

The design concept of the proposed scheme is shown in Figure 12. As discussed in [19], it is based on the addition of a gas turbine and a heat recovery steam generator to an existing combined cycle. The integration of new components into the baseline combined cycle is achieved by injecting the steam generated by the additional HRSG into the combustion chamber of the existing combined cycle.

The power increase is, thus, the sum of the power produced by the new gas turbine and the additional power generated in the original combined cycle, by the additional steam flow in the gas turbine and steam cycle.

The pressure required to inject steam into the turbine is relatively low compared to that usually employed in steam turbines. Therefore the additional heat recovery steam generator can have a single pressure level and a low pinch point, thereby reducing stack temperature (close to 120°C) and hence increasing exhaust heat recovery.

Another significant benefit of this solution is the ability to generate additional power without the need to find new sites, simply improving utilization of electricity generation sites where combined cycle plants are already installed, without affecting their excellent performance and environmental compatibility. Another significant feature of the proposed repowering scheme is its operational flexibility. Because of the inherent flexibility of the gas turbine, the entire additional section can be switched off in a short time, yielding a part load efficiency equal to that of the original plant. An international (PCT) patent application has been filed for the proposed repowering scheme [20].

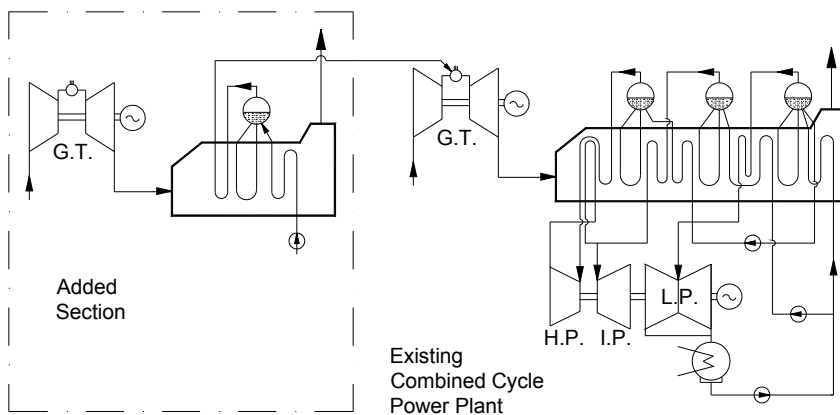

Fig. 12. Schematic diagram of combined cycle repowering through steam injection

The major drawback of this configuration is water consumption related to the flow entering the new HRSG, which is inevitably lost at the stack. This can limit the applicability of the present scheme to sites with large fresh water availability, though the specific water requirements are fairly low, as shown in [19].

Moreover, if a low temperature thermal load is available near the power plant, water can be recovered through steam condensation. The implementation of a water recovery technique has to be carefully evaluated, because of the very large size and the very low temperature level of such a heat sink.

5.2 Discussion of repowering performance

The scheme described above has been numerically studied using a modular simulation code [19], based on fundamental thermodynamic relations. In this simulation code each power plant component (gas and steam turbines, condensers, heat exchangers etc.) is modelled by means of mass and energy balances. A detailed analysis has thus been carried out, simulating the proposed repowering scheme with real data from present day power generating plants [19].

Several gas turbine models, both heavy-duty and aeroderivative units, were tested to assess the feasibility of repowering, the power augmentation achievable and its influence on energy conversion efficiency. The results of the analysis have shown that a power increase of up to 50%, with respect to the existing combined cycle plant, can be achieved. Moreover the additional electricity obtained from repowering is generated at high efficiency (49-52%), though the added section is not so efficient, while the cost of electricity is comparable with that of existing combined cycles. The analysis also showed that the proposed repowering scheme offers a variety of power control strategies and, hence, the possibility of achieving good part load behaviour, especially with the addition of a number of small aeroderivative gas turbines.

A further analysis has been carried out to evaluate the influence of the main added turbine features (β and T_{T1}), added HRSG operation (steam degree of superheat) and steam-to-air mass ratio (μ) on repowering performance.

For this purpose a repowering unit (GT and HRSG) has been added to a given baseline natural gas combined cycle plant, designated GE S109FA. It consists of a single General Electric gas turbine type PG9351FA, with design performance summarized in Table 2. Added gas turbine data have been taken to represent General Electric F-series gas turbines, while added HRSG always produces the maximum amount of steam, 10°C being the minimum temperature difference at pinch point and 90°C the minimum gas temperature within the stack.

Repowering performance has been evaluated in terms of incremental variables, i.e. marginal power output P and marginal efficiency η . The first is the power of the added gas turbine plus the power increase in the existing combined cycle due to steam injection (including both GT and ST contributions), the second is the ratio between the marginal power output and the marginal primary fuel power related to added GT and to steam injection into existing CC.

CC model designation	GE S109FA
Number and model of GT	1 x PG9351FA
Gas turbine	
Pressure ratio	15.4
Exhaust gas temperature, °C	610.6
Exhaust gas mass flow rate, kg/s	626.6
Net output, MW	254.2
Net efficiency, %	37.1
Steam cycle	
HP steam pressure, bar	125.1
HP steam mass flow rate, kg/s	69.7
IP steam pressure, bar	28.0
IP steam mass flow rate, kg/s	16.1
LP steam pressure, bar	4.2
LP steam mass flow rate, kg/s	9.8
Condenser pressure, kPa	5.1
Net CC output, MW	386.7
Net CC efficiency, %	56.3

Table 2. Design performance of baseline combined cycle

Varying β (from 10 to 30), T_{TI} (from 1200 to 1600°C) and degree of superheat (saturated and superheated steam), the repowering unit has always been rated such that the amount of steam generated for injection into the existing combined cycle matches the required μ value. To avoid compressor and turbine matching problems, considering that General Electric has offered injection for power augmentation for 40 years on all of its production machines [18], a steam-to-air mass ratio $\mu=5\%$ is assumed, corresponding to 30.6 kg/s of steam injected into the GE S109FA combustor.

As shown in Figure 13, injection of superheated steam produces higher values of marginal power and efficiency, for any β and T_{TI} .

Marginal power output increases with β , while it is little influenced by T_{TI} ; for a pressure ratio of 30, superheated steam injection produces a power increase of 165 MW, of which about 60% (102 MW) produced by the added gas turbine. On the contrary, marginal efficiency is strongly influenced by T_{TI} , especially at high pressure ratios. In this regard, for the added gas turbine operating at $\beta=30$, marginal efficiency attains 53.1% at $T_{TI}=1200^\circ\text{C}$ and 57.4% at $T_{TI}=1600^\circ\text{C}$.

More interestingly, the proposed repowering scheme offers the possibility of maintaining high efficiency over a wide range of marginal power outputs. In fact, marginal efficiency is strongly influenced by existing CC and added GT characteristics, but only slightly by the steam-to-air mass ratio μ . As shown in Figure 14, by varying μ from 3% to 9%, repowering can generate a marginal power output of up to 100 MW and 300 MW, respectively.

Therefore, though the steam mass flow rate for injection is limited by compressor and turbine matching problems or water availability and treatment requirements, the proposed repowering scheme could be beneficially implemented, as it is still characterized by high marginal efficiency and significant marginal power.

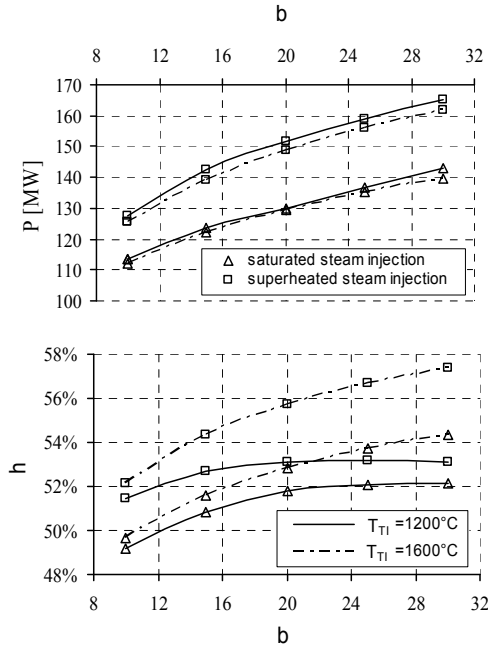

Fig. 13. Performance of CC repowering scheme in terms of marginal efficiency and power

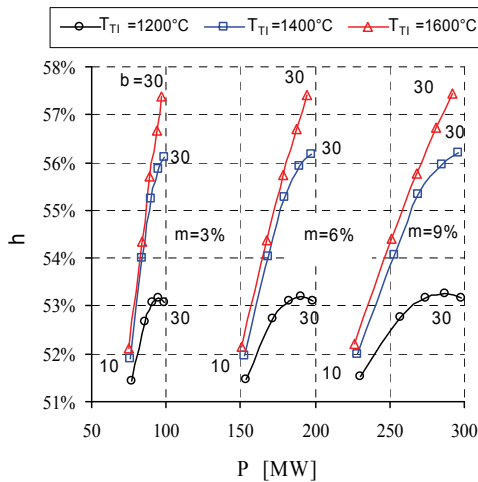

Fig. 14. Influence of steam-to-air mass ratio on performance of CC repowering scheme

Referring again to the combined cycle GE S109FA, Table 3 summarizes the improved performance that can be achieved adopting the repowering scheme for specific commercial gas turbines. In particular, two heavy-duty gas turbines (Siemens and Westinghouse V64.3A 401), with mechanical power in the 70-85 MW range, and aeroderivative (GE LM6000) of

smaller size are considered. For the latter, the effects of repowering are also assessed for integration with two or three gas turbine units.

The results obtained show that marginal efficiency is kept above 50%, even with small gas turbine units (around 10MW), while the power increase achieved (marginal power) is directly dependent on the flow rate of injected steam, as shown in Fig.15. Additional gas turbine accounts for about 60% of power increase - 56% for heavy duty GT and 64% for aero-derivative GT.

GT Number and model	GE LM6000	2 x GE LM6000	3 x GE LM6000	Siemens V64.3A	Westing. 401
Added GT power, MW	43.4	86.8	130.2	70.0	85.9
Added GT efficiency, %	41.3	41.3	41.3	36.8	36.5
Injected steam, t/h	45.9	91.7	137.6	99.3	119.8
Steam-to-air mass ratio, %	2.1	4.2	6.3	4.5	5.5
Marginal power, MW	68.2	137.0	205.9	124.0	151.0
Marginal efficiency, %	51.2	51.4	51.4	50.7	50.4

Table 3. Marginal efficiency and marginal power of repowered gas cycles

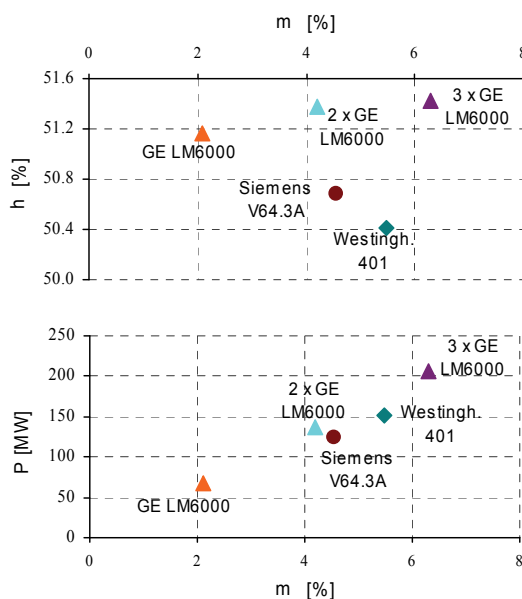

Fig. 15. Marginal efficiency and marginal power as a function of steam-to-air mass ratio

6. Conclusions

Different techniques for the internal or external recovery of exhaust heat from gas turbines have been investigated. Internal heat recovery techniques can be conventional (regeneration, steam injection) or unconventional (humid air regeneration, steam reforming), while external heat recovery can be performed using a steam bottoming cycle (combined cycle).

In order to compare the capabilities of the different solutions, a characteristic plane of exhaust heat recovery, based on a unified analysis approach, has been introduced. The performance plane of exhaust heat recovery is an effective tool for comparing various design solutions that are conceptually different and not directly comparable. On this plane each recovery technique is identified by a region, whose position and extent depends on typical parameters and characteristics of the baseline gas turbine, as well as on limitations related to minimum stack gas temperature and maximum mass flow rate increase in the turbine.

The characteristic plane indicates directly the performance obtainable with various heat recovery techniques. The analysis carried out has shown that performances close to combined cycle plants can only be achieved with combined recovery techniques (humid air regeneration or steam reforming of fuel), where the efficiency penalty is small at high maximum gas temperatures and low compression ratios.

Conventional combined recovery techniques (regeneration and steam injection) can compete with combined cycle plants at low turbine inlet temperature (1200°C), as they offer greater design simplicity, in spite of an efficiency penalty of a few percentage points.

Lastly, from the unified thermodynamic approach an innovative repowering scheme has been proposed. This allows to repower existing combined gas-steam power plants through the addition of a gas turbine and a one-pressure level HRSG, that feeds the output steam to the combustor of an existing gas turbine. This scheme significantly increases power output (50%) with fairly high marginal efficiency, in spite of the relative simplicity of the added components.

7. Nomenclature

n	steam-to-methane mole ratio
P	power
Q_1	primary thermal energy
T	temperature

Greek letters

β	compressor pressure ratio
η	efficiency
μ	steam-to-air mass ratio
ξ	direct recovery parameter
π	relative variation of power
τ	non dimensional flue gas temperature
χ	relative variation of primary thermal energy

Subscripts

AF	auxiliary fluid
DR	direct recovery
FG	flue gas
RG	regenerator
TI	turbine inlet

Acronyms

CCGT	combined cycle gas turbine
CRGT	chemically recuperated gas turbine
HAT	humid air regeneration
RG	thermodynamic regeneration
SI	steam injection

8. References

- [1] Heppenstall T, Advanced gas turbine cycles for power generation: a critical review, *Appl Therm Eng*, Volume 18, Issue 9-10 (1998) 837-846.
- [2] Jonsson M, Yan J, Humified gas turbines - a review of proposed and implemented cycles, *Energy*, Volume 30, Issue 7 (2005) 1013-1078.
- [3] Wei H, Hongguang J, Na Z, Xiaosong Z, Cascade utilization of chemical energy of natural gas in an improved CRGT cycle, *Energy*, Volume 32, Issue 4 (2007) 306-313.
- [4] Kuroki H, Hatamiya S, Shibata T, Koganezawa T, Kizuka N, Marushima S, Development of elemental technologies for advanced moist air turbine system, *J. Eng. Gas Turbines Power*, Volume 130, Issue 3 (2008).
- [5] Carapellucci R, A unified approach to assess performance of different techniques for recovering exhaust heat from gas turbines, *Energy Convers Manag* 50 (2009) 1218-1226.
- [6] Poullikkas A. Parametric study for the penetration of combined cycle technologies into Cyprus power system. *Appl Therm Eng* 2004;24:1675-85.
- [7] Lozza G, Turbine a gas e cicli combinati, Progetto Leonardo Bologna.
- [8] GRTN, Dati statistici sull'energia elettrica in Italia, 2008, Gestore Rete Trasmissione Nazionale, www.grtn.it.
- [9] Fonte: Rapporto trimestrale del Ministero dello Sviluppo Economico, <http://www.sviluppoeconomico.gov.it>
- [10] Cheng DY, Regenerative parallel compound dual-fluid heat engine. US Patent 4,128,994; 1978
- [11] Macchi E, Consonni S., Lozza G, Chiesa P. An assessment of the thermodynamic performance of mixed gas-steam cycles: Part A - Intercooled and steam-injected cycles. *ASME J Eng Gas-Turbines Power* 1995;117:489-98.
- [12] Poullikkas A, An overview of current and future sustainable gas turbine technologies, *Renew and Sustain Energy Reviews* 9 (2005) 409-443.
- [13] Traverso A, Massardo AF. Thermodynamic analysis of mixed gas-steam cycles. *Appl Therm Eng* 2002;22: 1-21.
- [14] Carcaschi C., Facchini B., Harvey S., Modular approach to analysis of chemically recuperated gas turbine cycles, *Energy Convers Manag* 39 (1998) 1693-1703.
- [15] GE Energy, Gate Cycle manual 2005, California, GE Enter Software LLC.
- [16] Carapellucci R, Milazzo A, Thermodynamic optimization of a reheat chemically recuperated gas turbine, *Energy Convers Manag* 46 (2005) 2936-2953.
- [17] Walsh P.P., Fletcher P., Gas Turbine Performance, ASME Press, 2004
- [18] Johnston JR. Performance and reliability improvements for heavy-duty gas turbines, GER-3571H, GE Power Systems, Schenectady, NY; November 2000.
- [19] Carapellucci R, Milazzo A. Repowering combined cycle power plants by a modified STIG configuration. *Energy Convers Managem* 2007;48(5):1590-600.

- [20] Carapellucci R, Milazzo A, Scheme of power enhancement for combined cycle plants through steam injection. International Patent (PCT) application n. PCT/IT2006/000332, WO/2006/123388, November 23; 2006.

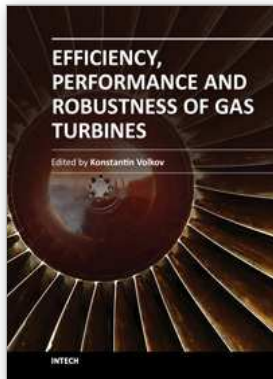

Efficiency, Performance and Robustness of Gas Turbines

Edited by Dr. Volkov Konstantin

ISBN 978-953-51-0464-3

Hard cover, 238 pages

Publisher InTech

Published online 04, April, 2012

Published in print edition April, 2012

A wide range of issues related to analysis of gas turbines and their engineering applications are considered in the book. Analytical and experimental methods are employed to identify failures and quantify operating conditions and efficiency of gas turbines. Gas turbine engine defect diagnostic and condition monitoring systems, operating conditions of open gas turbines, reduction of jet mixing noise, recovery of exhaust heat from gas turbines, appropriate materials and coatings, ultra micro gas turbines and applications of gas turbines are discussed. The open exchange of scientific results and ideas will hopefully lead to improved reliability of gas turbines.

How to reference

In order to correctly reference this scholarly work, feel free to copy and paste the following:

Roberto Carapellucci and Lorena Giordano (2012). The Recovery of Exhaust Heat from Gas Turbines, Efficiency, Performance and Robustness of Gas Turbines, Dr. Volkov Konstantin (Ed.), ISBN: 978-953-51-0464-3, InTech, Available from: <http://www.intechopen.com/books/efficiency-performance-and-robustness-of-gas-turbines/the-recovery-of-exhaust-heat-from-gas-turbines>

INTECH

open science | open minds

InTech Europe

University Campus STeP Ri
Slavka Krautzeka 83/A
51000 Rijeka, Croatia
Phone: +385 (51) 770 447
Fax: +385 (51) 686 166
www.intechopen.com

InTech China

Unit 405, Office Block, Hotel Equatorial Shanghai
No.65, Yan An Road (West), Shanghai, 200040, China
中国上海市延安西路65号上海国际贵都大饭店办公楼405单元
Phone: +86-21-62489820
Fax: +86-21-62489821

© 2012 The Author(s). Licensee IntechOpen. This is an open access article distributed under the terms of the [Creative Commons Attribution 3.0 License](#), which permits unrestricted use, distribution, and reproduction in any medium, provided the original work is properly cited.