

# Sustainable Forest Management Techniques

K.P. Chethan, Jayaraman Srinivasan, Kumar Kriti and Kaki Sivaji  
*TCS Innovation Labs Bangalore, Tata Consultancy Services,  
India*

## 1. Introduction

Forests being an indispensable resource play an important role in maintaining the earth's ecological balance. The major contributors of deforestation are logging off of trees (legal or illegal), tree theft, forest fire etc. Large scale deforestation has negative impact on the atmosphere resulting in global warming, flash floods, landslides, drought etc. Due to these adverse effects, forest management department all over the countries have taken steps for monitoring the forest to prevent deforestation. Several surveillance techniques have been employed for monitoring and prevention; they are broadly classified as Ground-based sensing techniques and Remote sensing techniques.

Surveillance plays an important role in forest management. It had been used in the past and is still being used for monitoring and information collection. Ground-based techniques generally include surveillance by on-site security staff and mobile patrols monitoring the property by water, land and air (Magrath et al., 2007). Some complementary systems such as Fixed Earth System are also used with observation towers located at strategic points with specialized personnel for observing and detecting the presence of fire. All these systems are expensive and time consuming, requiring a lot of resources.

Nowadays, remote sensing technologies are also used like, aerial photographs, automatic video surveillance, wireless surveillance systems and satellite imagery. Satellite imagery is very costly for use in monitoring any illegal activity like trespassers, tree theft and deforestation (if they are able to detect at all). On the other hand, with the technological advancements in wireless communication, various low power, and low cost, small-sized sensors nodes are available which can be readily deployed to monitor environment over vast areas. Wireless Sensor Networks (WSNs) technology is being used widely for monitoring and controlling applications. Currently three main wireless standards are used namely: WiFi, Bluetooth and ZigBee. Amongst them, ZigBee is the most promising standard owing to its low power consumption and simple networking configuration. Wireless sensor network based surveillance systems for remote deployment and control are more cost effective and are easy to deploy at location of interest. They can even reach those areas where satellite signals are not available. Moreover, they can be configured to monitor large areas and they have secure mode of data transmission.

Environmentally, WSNs finds immense application in land management, agriculture management, lake water quality management, forest fire detection, tree theft prevention and also in the prevention of deforestation. In addition, WSN system has also been used for strain monitoring in railway bridges. (Bischoff et al., 2009), developed an event based strain

monitoring WSN system for railway bridge. They used low power MEMS acceleration sensors for detecting an approaching train. Whenever this event was detected, strain gauges were operated and measured data was used for cycle counting based fatigue assessment of steel bridges. This event based detection was developed to manage the power consumption and make the system more energy efficient. Moreover, solar rechargeable battery powered base station was used to increase the system lifetime.

WSN system has also been used for landslide monitoring and prevention. (Rosi et al., 2011) discussed the implementation and deployment details of a WSN system for landslide monitoring in Northern Italy Apennines. Six Micaz nodes having a 2 axis accelerometer for sampling vibrations were used. These vibrations were a result of slope movements caused by landslides. The data measured by the sensor nodes were routed to the base station and finally sent to the base station following a predefined static routing table. These examples give a fairly good idea of the amount of work and research going on in WSN area making them the most promising technology to use for monitoring and control purpose in diversified fields.

A lot of research has been done using WSN for forest monitoring either for fire prevention or for monitoring the illegal logging activity. Some researchers have proposed algorithms for detection and prevention and have simulation results verifying their control. On the other hand, some have come up with the design, implementation and deployment of the system. The work on forest monitoring is not limited to fire and deforestation detection and prevention but also includes preserving and conserving the flora and fauna of the forests. A brief summary of the work done in this domain is given below.

(Awang & Suhaimi, 2007), developed a WSN based forest monitoring system called RIMBAMON. This system consisted of sensor nodes deployed in the forest at specific distances for capturing temperature, light intensity, acoustic, acceleration and magnetic readings. MICA2 Mote was used for implementation for its long range in ISM band. These sensors were either mounted on the trunk of the tree at the ground level or kept along the roadside. The sensors used helped in monitoring any illegal logging activity in addition to detection of fire in the forest. Temperature and light intensity sensors gave an indication of both logging activity as well as presence of fire. On the other hand, acoustic sensors gave more information on logging activity alone owing to the abnormal sound associated with the usage of machinery, tractor or chainsaw. The system was simulated and tested well to capture and transmit data to the base station. It displayed the acquired data in form of graphs, tables and maps to help in taking prompt action. However, the system lacked remote monitoring through the web, which could be useful in monitoring hostile areas.

(Harvanova et. al., 2011) proposed a Zigbee based WSN system for detection of wood logging using real time analysis of sounds from surroundings. The WSN system periodically acquires sound samples, processes it and transmits it to the central server. Tools which are vastly used for deforestation are chainsaw. There is a characteristic sound associated with a logging activity. Whenever, the sound samples acquired from the sensors matches the sound samples of logging tools, a logging activity is detected and the responsible personnel is notified through an e-mail or a SMS alert.

(Soisoonthorn & Rujipattanapong, 2007), also studied the unique acoustic characteristics of the chainsaw and used it for detecting the activity of chainsawing leading to deforestation. The algorithm was based on a limited energy sensor node and combined three techniques which included adaptive energy threshold, delta pitch detection and energy band ratio in high frequency range. Since the energy characteristic of chainsaw is quite constant, state

machine used was further simplified for detection purpose. They could achieve the detection accuracy of 90.8% with this method.

(Figueiredo et. al., 2009), studied the communication performance of WSN for preserving and conserving the flora and fauna of rainforests. A set of experiments were carried out to assess how data communication is affected by environmental parameters like, forest density, humidity and extreme temperature variations. It was concluded that communication range of a WSN system deployed in a dense forest gets reduced by 78% as compared to deployment in any other environment.

A lot of study has been done on early fire detection and a number of techniques and sensor combinations have been investigated. Techniques include remote sensing techniques as well as event detection for wireless sensor networks. (Bahrepour et. al., 2008) presented a survey on automatic fire detection from a wireless sensor network perspective. The survey included fire detection techniques for residential areas; for forests and contribution of wireless sensor networks in early fire detection. Since the sensors used for detection were prone to noise, multiple sensors were used to reduce the false alarms generated in case of single sensor usage. Usually temperature sensors are combined with gas concentration sensors for better fire detection. In this study, it was concluded that in residential areas, ION detectors are more beneficial for flaming fire detection. On the other hand, photo detectors are more beneficial for non-flaming fire detection. Fire Weather Index (FWI), which resulted from several years of forestry research, can be used as promising factor for forest fire detection.

(Lozano & Rodriguez, 2010), designed a WSN based system which monitored temperature and humidity for early detection of forest fires. Weather conditions especially temperature, humidity and rainfall determines the degree and speed by which fire spreads in the forest. The correlation between the various weather elements and flammability of the waste of branches and trees helps in predicting the risk of fire at any given location. Mesh topology was used to configure the communication network and temperature and humidity sensors were used to gather the data from the remote location. Through simulation it was shown that the system was capable of detecting fire at an early stage thereby, protecting the nature reserves.

(Zoltan Kovacs et. al., 2010), presented a case study of a simple, low cost WSN system implementation for forest fire monitoring. Smoke detectors and temperature sensors were used to detect forest fire. A simple star topology was used to cut down on the computation and power consumption. (Zhang et. al., 2009), proposed a Zigbee based WSN system for forest fire detection in real-time so that decision to prevent or extinguish fire can be taken in real-time. The sensor nodes comprised of humidity, temperature, wind speed, wind direction, smoke, pressure and other fire monitoring sensors. The data collected by them was sent to the cluster head which was responsible for data aggregation and transmission. Network co-ordinators were responsible for network building, access control and other network management functions. The data was transmitted to the routers which established local databases and sent the data to the host for monitoring purpose over the internet. Some important factors related to ad hoc network technology, forest-fire forecasting model and determination of effective communication distance was discussed.

(Wang et al., 2010), proposed a new wireless network implementation for forest fire monitoring based on Zigbee and GPRS technology. This work is quite similar to the one adopted by us in monitoring illegal logging of trees in the forest. This system was capable of

transmitting the data collected by the wireless network to FTP server through GPRS so that real-time data can be made available to the experts to help in decision making. The hardware schemes and program flows of the system were given. (Fonte et. al., 2007), designed a low cost system-on-chip microwave radiometer on silicon for remote sensing of temperature to find application in fire prevention. A detailed system analysis was carried out by means of simulations to study its feasibility in civil and environment safeguard applications.

(Gil et. al., 2010), came up with a fire monitoring device which provides visualization services after gathering GPS and sensor data from the micro-system (quad rotor). The sensors used were CO<sub>2</sub>, humidity, fume and temperature. The data was wirelessly transmitted and displayed on the map using open map API to give information where the fire broke out. (Hefeeda & Bagheri, 2007), proposed a WSN system for forest fire modelling and early detection. Forest fire was modelled according to Fire Weather Index (FWI) system which is considered as one of the most comprehensive forest danger rating systems in North America. A k-node coverage problem in WSN for forest fire detection was studied and an approximation algorithm was proposed which had better convergence, promised optimal number of sensor usage and doubled the network lifetime than other existing algorithms.

Some problems on optimization related to sensor nodes deployment were also explored. (Al-Turjman et al., 2009), studied the various design factors important for WSN system deployment especially in harsh environment like coverage, connectivity and lifetime. They explored the problem of placement of the relay nodes in 3D forest space. They formulated an optimization problem which focuses on maximizing the network connectivity with a limit on the number of relay nodes used. They came up with a threshold on a minimum number of relay nodes used for desired connectivity in harsh environment.

Apart from using WSN for this application, some researchers have explored other technology also. (Luming et al., 2008), studied and came up with a new technology which combined the advantages of video monitor and GIS systems for fire prevention. These two techniques complemented each other well and helped in increasing the accuracy of fire detection and hence prevention, reducing the false alarm. Also, synchronous tracking of video monitored areas in GIS of forest resources helped in getting more accurate information of the land form of the affected area.

Monitoring deforestation is a very complicated process. It becomes even more complicated with the increasing need of resources. Our work addresses the issue of deforestation detection and prevention using an event based WSN system. The design and implementation details of the sensor nodes are given. Mesh routing algorithm is used here for routing data packets to the sink whenever an event is detected.

Following the brief introduction to the problem being addressed in this chapter, the other sections are organized as follows: Section 2 discusses the design concept of a WSN setup for monitoring large space like forests. This includes the advantages and challenges encountered in deployment of WSN for such an application. Followed by this, Section 3 gives a detailed description of the WSN prototype developed which finds application in the detection of tree theft, forest fire and deforestation. Section 4 discusses the challenges faced in the deployment of the proposed prototype. The power requirement of the sensor nodes is handled by the power management unit which has a provision of harvesting energy from the surrounding to increase the network deployment lifetime. The various 'energy harvesting' techniques which can be used for recharging the sensor nodes are discussed in

Section 5. Finally, we have Section 6 giving the summary and important conclusions of the work discussed.

## 2. Design concept of WSN system for forest monitoring

Designing, deploying, and evaluating a novel wireless systems at a large scale requires substantial effort. One of the major applications of wireless sensor networks is in event detection. Here, a sensor network is monitoring certain phenomenon and the respective communication node needs to get triggered on occurrence of a certain event. Subsequently the event needs to be reported to the sink node as quickly as possible. The communication nodes can be sleeping for most of the time to conserve power since most of the events are rare in nature. But there must be a mechanism to wake them up for quick event transmission through appropriate synchronization. Some of the prominent applications of this category are detection of fire, intrusion, earth quake, landslide, theft of assets and other surveillance applications. However, it is still a great challenge to design a wireless sensor network system for rare event detection; where network lifetime and robustness is a major concern. Some of the recent developments include campus-wide and community-wide wireless mesh networks (Bicket *et al.*, 2005; UCSD Active Campus; Camp *et al.*, 2006), and real-world sensor network deployments in environments as diverse as forests, active volcanoes, and bridges. WSN system design for forest monitoring involves:

- Sensors
- Design of low power wireless communication module
- Simulation and implementation of energy efficient protocol
- Deployment strategies
- Middleware

### 2.1 Sensors

One of the main goals of sensor network is to provide accurate information about a sensing field for an extended period of time. This requires collecting measurements from as many sensors as possible to have a better view of the sensor surroundings. However, due to energy limitations and to prolong the network lifetime, the number of active sensors should be kept to a minimum. To resolve this conflict of interest, sensor selection schemes are used. The sensor selection problem can be defined as follows: Given a set of sensors  $S = \{S_1, \dots, S_n\}$ , we need to determine the "best subset"  $S_k$  of  $k$  sensors to satisfy the requirements of one or multiple missions. The "best subset" is one which achieves the required accuracy of information with respect to a task while meeting the energy constraints of the sensors. So, we have two conflicting goals: (1) to collect information of high accuracy and (2) to lower the cost of operation. This trade-off is usually modelled using the notions of utility and cost:

*Utility*: accuracy of the gathered information and its usefulness to a mission.

*Cost*: These consist mainly of energy expended activating and operating the sensors which is directly proportional to number of selected sensors  $k$ . Another cost factor that can be considered is the risk of detecting active sensors especially if wireless communication is used. Table 1 shows the selection of sensors for different hazards

Hazard	Application	Sensor Application
Earthquake/wind	Observation	Acceleration
	Experiment	Acceleration strain
	Structural control	Acceleration
	Health monitoring	Acceleration/strain/Displacement
	Damage detection	Acceleration/strain/Displacement
Fire	Fire detection	Temperature/Smoke/Acoustic
	Gas leak detection	Olfactory
	Alarm ,warning	Sounder
	Evacuation control	Temperature/Smoke/Acoustic/Light
Crime	Surveillance	Acceleration/Light/Acoustic/Camera
	Security alert	Sounder

Table 1. Different Sensors used for Sensing Different Hazards

## 2.2 Design of low power wireless communication module

Power Management is the major challenge in wireless sensor network design. Sensor nodes of the WSNs are battery powered due to their nature of application and deployment requirement. However, batteries life time is limited life which affects the performance of the WSN and it needs replacement from time to time. To overcome this issue, lifetime of the battery can be extended by adopting the following approaches:

1. Design of low power sensor nodes
2. Energy harvesting

Many applications require periodic monitoring rather than continuous monitoring of elements of interest. For such applications, the system need not be in awake state (high power consumption) all the time; instead it can be in sleep state (low power consumption) till it is required to monitor the elements of interest. This can lead to considerable reduction in power consumption. Many low power chipsets are now available which can be configured for such an application.

Additionally, harvesting energy from the surrounding can play a significant role in improving the self sustainability of the WSN system. Once WSN is deployed it is expected to work continuously and autonomously with minimum or no human intervention. Therefore there is a need for sensor nodes to be self sufficient in terms of energy consumption. Energy harvesting can be performed from sources like solar, vibration, RF etc for recharging the sensor nodes batteries, thereby increasing their lifetime. The different energy harvesting techniques which can be employed depends on the location of WSN deployment. Further, the different techniques and their implementation is discussed in Section 5.

## 2.3 Protocol section and simulation

In WSN, most sensor networks are application specific and have different requirements. On the other hand the sensor nodes have a limited transmission range, processing and storage capabilities, energy resources as well. The routing protocols for wireless sensor networks are responsible for maintaining the routes in the network and have to ensure reliable multi-hop communication under these conditions. In consequence, all or part of the above mentioned design objectives need to be considered in the design of sensor network protocol. (Singh et al., 2010) provided a survey on challenges involved in the design of protocols for WSN. Below is the list of requirements to be considered in order to design and develop a good quality application protocol for WSN.

- Small node size
- Low node cost
- Low power consumption
- Scalability
- Reliability
- Self-configurability
- Adaptability
- Channel utilization
- Fault tolerance
- Security
- QoS support
- Sensor locations
- Limited hardware resources
- Massive and random node deployment
- Network characteristics and unreliable environment
- Data aggregation
- Diverse sensing application requirements

#### **2.4 Middle ware**

As WSN vision evolves, multiple paradigms co-exist as single, multiple and internet-scale sensor networks. A diversity of approaches has been proposed to deal with the multitude of WSN application requirements. Current systems do not address most of these requirements adequately; especially the aspects like support for security, trust, transparency, mobility, and heterogeneity.

Middleware for sensor networks is an emerging and very promising research area. Most of the reported works on sensor middleware are at an early stage, focusing on developing algorithms and components for data aggregation, self organization, , network service discovery, routing, synchronization, optimization etc to build higher level of service structures. They often lack attention for integrating these algorithms and components into a generic middleware architecture, and for helping application developers to compose a system that exactly matches their requirements. There are still few widely accepted software standards for middleware. SensorML (Sensor Model Language) for service discovery and Global Sensor Networks (GSN) (Middleware for Sensor Networks) or integrating virtual sensors have the potential for adoption. We also see the relevance of context aware computing technologies (Ontologies and expert systems) in creating a semantic layer for WSN applications. However, in this chapter the implementation was performed in the hardware without any separate OS.

Microsoft has a web based visualization service called Sense Map (SensorMap) which can be used to host and share sensor data. Google Maps, Google Earth, Virtual Earth, are also provided as interfaces to the final user. In addition to computers, PDA (Personal Digital Assistant) and mobile phones can be used to monitor the data and subscribe to alert services. Also it will be interesting to see how virtual reality environments can provide effective visualization environment for WSN applications. WSN characteristics require a specific approach for middleware development that goes beyond dealing with resource constraints. It involves an end-to-end approach that handles the WSN as a whole rather than a group of individual nodes. This implies considerable consequences for typical middleware

services such as mobility, coordination, service discovery, security, data aggregation, quality of service, handling hardware heterogeneity, handling communication errors, scalability, and network organization. Good architectures are needed to integrate new sensor services to integrate safely with legacy systems; enhanced programming models, event propagation models, and data models to accommodate the requirements of sensor applications and services; and inventive design. There is no single middleware existing till date which addresses all these requirements.

## **2.5 Deployment**

In general, deployment establishes an association of sensor nodes with objects, creatures, or places in order to augment them with information-processing capabilities. Deployment can be as diverse as establishing one-to-one relationships by attaching sensor nodes to specific items to be monitored (Przydatek et al., 2003), covering an area with locomotive sensor nodes (Bulusu et al., 2004), or throwing nodes from an aircraft into an area of interest (Karlof & Wagner, 2003). Due to their large number, nodes have to operate unattended after deployment. Once a sufficient number of nodes have been deployed, the sensor network can be used to fulfil its task. This task can be issued by an external entity connected to the sensor network.

## **3. Proof of Concept (PoC) for forest monitoring**

The main objective of our system is to monitor tree theft/fire in the forest and alert using an event based wireless sensor network. In forest monitoring application, events like tree theft, fire etc. occur rarely, so in our implementation, the communication nodes are kept in sleep mode (until any event is detected) to cut down on the power consumption. Whenever an event is detected by sensor, it triggers the communication nodes. Subsequently, the event is reported to the sink node as quickly as possible and an alert is generated. In addition to event based monitoring, our system incorporates energy harvesting technique to power the sensor nodes and for carrying out other power management related tasks. The detailed description of the design and implementation of the proposed system is given below.

### **3.1 Communication node design**

This section describes the sensor node architecture which has been designed and developed for the low power application stated above. Fig. 1 shows the functional block diagram of the sensor node developed for forest monitoring. The sensor node architecture mainly consists of a SOC (system-on-chip) for data collection, processing, networking and controlling; sensors for event detection; power supply for meeting the power requirements of the sensor node and RF energy harvester system for harvesting energy from RF. The hardware details of the various components of the sensor node are described below.

#### **3.1.1 SOC (System-on-Chip)**

MC13213 system on chip (SOC) from Freescale Semiconductor has been used for this implementation. The interrupt which is generated by the Key Board Interrupt (KBI) has been used to wake up the controller from the sleep mode. Whenever SOC receives an interrupt to KBI from the tilt/temperature sensor, it sends low signal on the corresponding KBI and wakes up the controller which starts its service from the corresponding service routine.



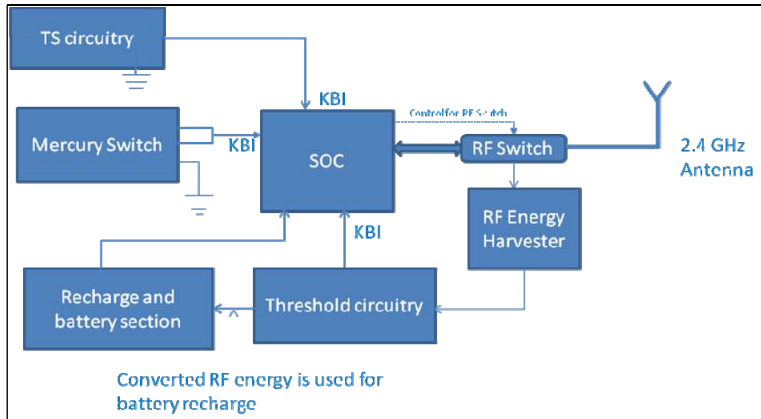

Fig. 1. Functional Block Diagram of the Sensor Node developed for Forest Monitoring

On the other hand, when the neighbor nodes want to send the data, it first sends the RF signal and then sends the data. Received RF signal will interrupt the node and energy storage will occur based on signal threshold. When RF signal is within the predefined thresholds, threshold circuit sends an active low signal to KBI. KBI wake up the controller and start the corresponding service routine to listen its neighbour. If the received RF energy is out of these two thresholds, it activates the energy harvest mode.

Energy of RF signal =  $V_f$

if  $TH_1 < V_f < TH_2$  - KBI interface

Else enable the RF harvesting

### 3.1.2 Sensor section

In our system, two sensors have been incorporated for detecting tree theft/fire. Mercury switch sensor (also known as a mercury tilt switch) has been used to detect tree fall/cut and simple thermistor based temperature sensor has been used to detect sudden high ambient temperature which is a probable cause of fire. The tree fall/cut is detected when the mercury switch is tilted in the appropriate direction, which causes mercury to flow and touch the contacts, thereby completing the electrical circuit. Tilting the switch in the opposite direction causes the mercury to move away from the set of contacts, thereby resulting in open circuit. This switch is interfaced to the micro-controller (SOC) to generate the interrupt whenever a tilt event occurs. When the tree bends or tilts more than 50°, a contact is made between the device ground and the KBI pin, resulting in fall event detection which wakes up the node for alert transmission. Fire is detected with the help of a simple thermistor sensor with circuitry to trigger the micro-controller (SOC) via KBI pin. Whenever the sensed ambient temperature goes beyond a prefixed threshold value (due fire catch etc.), this circuitry raises the voltage at the KBI pin of micro-controller which in turn takes care of sending an alert to the destination.

### 3.1.3 Power section

This section deals with the power supply requirements of the various components of the sensor node namely, sensors, SOC and threshold circuitry. The sensor node is powered

using rechargeable alkaline battery (two 1.5V cells in series). Since our system is an event based system, the system spends most of the time in sleep mode (consuming  $\mu$ Amps of current), so the current consumption of this system is very low. Therefore, once the battery is fully charged the system runs for minimum six months. In addition to that, RF energy harvesting technique is implemented in this system to recharge battery, which further increases the sensor network lifetime. RF energy is extracted from RF transmitters/senders specially designed for this purpose. Typically, RF senders are required for every 50 nodes, whose job is to transmit the RF signal with high power so that the nodes which receive the signal with high power will recharge their battery. Such RF sender is required to run for one or two days once in six months.

RF harvesting technology can be used for multiple frequencies and can generate standard or custom output voltages. Batteries or any other energy storage devices can be recharged easily either in close proximity or remotely. In addition, some low power devices can be directly driven from the received RF power. In our application, harvester system for RF consists of Power harvester P1100 module from Powercast (Power harvester P1100 Module Datasheet), which converts received RF energy into DC power with high efficiency. With the help of a threshold circuit, this chip is used for two purpose here, one for waking up the sensor node and other for recharging the battery. When any neighbour node wishes to transmit data, it first sends the RF energy for approx.10 seconds. This is received by surrounding nodes and goes through P1100 module to get converted into DC power. The converted DC power is fed to the threshold circuit which decides whether the RF signal received is to wake up the controller or to recharge the battery. The decision depends entirely on the power available at the output of P1100 module and the threshold limits adopted. Depending on the decision, a KBI interrupt is generated if it is required to wake up the neighbouring nodes for data transmission.

### 3.2 Network design architecture

One of the important aspects of the network design is the communication of data among the sensor nodes. Therefore, it is highly necessary to design efficient routing algorithm considering multiple constraints that is inevitable in wireless environment. There are two types of routing possible based on the functionality of the nodes in the network namely, flat routing and hierarchical routing. In hierarchical routing, the whole network is divided into multiple hierarchies. Each node has different functionality with respect to the level of hierarchy. Zigbee routing is one such hierarchical routing protocol where the nodes are organized in a hierarchical manner. However, in flat routing protocol, also known as mesh routing protocol, all the nodes in the network are organized in the same hierarchy i.e. all nodes in the network have the same hardware and functional properties. Directed diffusion is one example of this type of routing. In this study, we propose a mesh routing protocol system suitable for monitoring the environment, wherein the nodes in the network are in the same hierarchy. The proposed protocol for this study is an event based protocol, where the nodes generate data corresponding to the event occurred and communicates it to the sink. The protocol has two phases: Configuration Phase and Routing Phase.

*Configuration Phase:* In this phase, the whole network is in wake up state. The sink node sends the CONFIG packet which traverses through the network in multiple hops. All the nodes receive the CONFIG packet and construct the routing table. Routing table is used to route the data packets towards the sink node. Once the network is configured, the sink broadcasts the sleep packet throughout the network and all the nodes go to sleep mode.

*Routing Phase:* In this phase, an event detected in the vicinity of the sensor, wakes up the sensor node and records the sensed data at the node. This node then transmits a beacon signal for a pre-defined period of time to wake up the sensor nodes within its range (neighbours). The node selects the upstream node (towards the sink) using routing table to forward the data packet. A similar procedure is carried out on the selected upstream nodes to route the data packets to the sink node. The nodes enter back into sleep mode after a specified period of time.

### 3.3 Visualization and monitoring

A tool for monitoring and visualization of the forest related events was developed. It supported major features required for middleware for many practical applications involving sensor data collection, visualization and monitoring. The developed framework had two flavours. The first one is a PC based standalone tool, named as Wi-SenseScope developed in Java. It has a graphical user interface (GUI) supporting commands for network visualization including topology, node parameters, and sensor data. The GUI supports the specification of background and foreground image files to be displayed to adapt to various application scenarios. Events can be defined by specifying a mathematical expression based on the sensor parameters. This expression will be evaluated in real-time whenever the dependent parameter changes. Once an event is detected, there is a facility in this tool to link an action to a specific event based on user's discretion.

The second one is a web based visualization system, named as Web-SenseScope (shown in Fig. 2), which integrates Google maps and other map sources as geographical reference layers. Markers are used for identifying the sensor node deployment which displays current details on mouse click. The WSN is represented in XML in a hierarchical structure. The structure is Network -> Clusters-> Nodes-> Sensors. A text based structure view is incorporated to enable the expandable tree visualization. The desired Sensor-ID could be selected to view the sensor data in text format or as a time series plot.

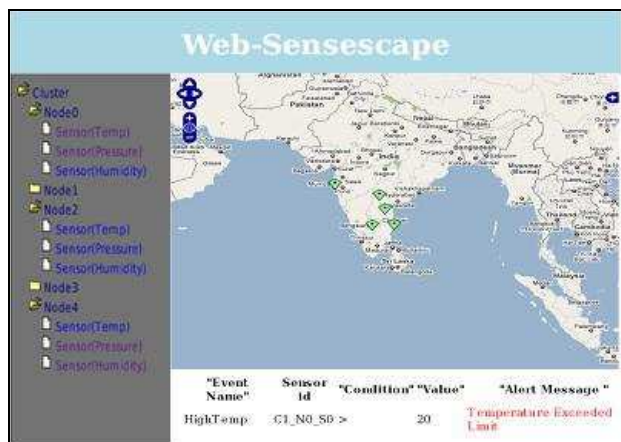

Fig. 2. Web based WSN Monitoring and Visualization

Specific to forest monitoring, this can be loaded with pre-defined blue-print of the forest which is to be monitored. An alert window provides real-time display of events that got triggered

based on the events defined. Appropriate audio-visual messaging or alarms can be invoked on the occurrence of specific events. For example, whenever tree falls it shows which tree has fallen by highlighting the tree and proper audio message to take necessary action. This framework is being extended to incorporate visualization of multiple data types and sources including cameras, microphones, GPS (Global Positioning System), medical sensors etc. represented with SensorML. Network management functionality is also being incorporated to enable interactions with the sensor nodes deployed in the field. The middleware architecture has been developed keeping in view of the flexibility, scalability and portability required for supporting multiple networking standards, applications and platforms. The next section demonstrates the application in the deployment scenario.

### 3.4 Deployment of WSN for forest monitoring

The typical setup of the forest monitoring application is shown in Fig. 3. Few wireless nodes (say N1 to N10) which are responsible for sensing the desired physical entities and communicating this information are deployed in the forest. The information gathered by the nodes is transferred to their upstream routers. One Base Station (BS) is used which gathers the information from the routers. This BS is in turn connected to host system through wireless connection which finally processes the information received from the BS and takes appropriate decision.

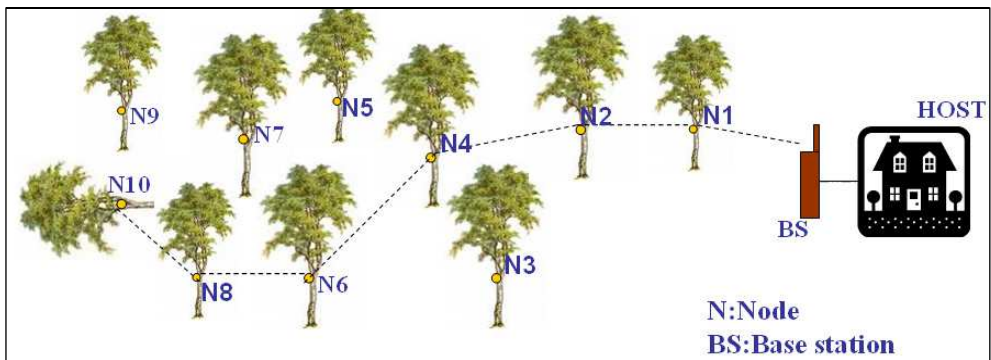

Fig. 3. Demonstration Scenario of detecting a Fallen Tree using WSN

In our application, the wireless sensor nodes are mounted on each tree in order to protect the tree from critical events like theft, fire etc. Wireless T-mote is the name given to each node. Few T-motes were attached to the tree models. It formed a simple dynamic tree network topology to route packets to the host system. The fall detection approach adopted by us can be explained with the help of Fig. 3. As can be seen from the figure, fall event is detected on N10 which may be generated in case of tree theft. When the tree is falling the tilt sensor generates the event and wakes up the node. This node transmits a beacon signal for a pre-defined period of time to wake up the sensor nodes within its range. A dynamic routing path created in the routing phase is used to send this message to the base station which is connected to the host system. In this example, routing path created via Node 8, 6, 4, 2, 1 is used for alert sending. Host system running the Wi-Sensescape application, provides services like: sensor data visualization and analysis, map of the network topology, alarm services, network analysis

and filtration of sensor data. This helps in studying and analyzing the activities and behaviour of the WSN deployed for monitoring purpose.

### 3.5 Results and discussions

This section discusses the important results and observations of the proposed system. In this work we have considered three scenario to calculate the power consumption of the sensor node, they are: (a)when there is no event, (b)there is event from the sensor (tilt sensor/temperature ) and (c) there is event from the neighbor to forward the data. After the event occurs, it wakes up the SOC and starts the operation. The SOC's current consumption is typically around 50mA, it continues till the communication is completed (generally it takes 3 to 4 seconds to complete its operation) and then it goes to sleep mode. Therefore, once the event occurs, the battery life is reduced by ~6 hours from the overall life of the battery. Table 2 shows the power consumed by the mote when there is no event.

Components	Mode of Operation	Average Current Drawn
Threshold circuit	Active	100 $\mu A$
SOC	Sleep	10 $\mu A$
Leakage	-	15 $\mu A$
Total current required by the sensor node		125 $\mu A$
Power required = 3V * Total current		~ 375 $\mu W$

Table 2. Power Calculation with No Event

$$\text{Total hours} = \frac{\text{Battery Capacitor}(BC)}{\text{Battery Drain of Usage}} = \frac{2000mA}{125\mu A} = 16000$$

$$\text{Total days} = \frac{\text{Total hours}(TH)}{\text{Hours of Usage per day}} = \frac{16000}{24} \cong 2\text{years}$$

*Routing Protocol:* The simulation of the routing protocol has been performed in NS-2 ver 2.32 platform. We choose the amount of delay to analyze the performance of the protocol. Average Delay measures the average one-way latency observed between transmitting information from the source and being received by the sink. We study this metric as the function of the sensor network size. We generated variety of sensor network scenarios with different network sizes to study the performance of the routing protocol as a function of network size. In every experiment we study the performance with 10 different sensor network scenarios with the network size ranging from 50 to 150 nodes with the increment of 25 nodes. We perform the simulation by keeping the network density constant of about 100 nodes/m<sup>2</sup> throughout the experiment. We chose the transmission range of the nodes to be 10m. The other sensor network fields are generated randomly thereby keeping the node density constant. We used the default 802.15.4 MAC and physical layer stack provided by the NS-2. We carried out the experiment by making a single sink and single source node participate in the event generation. Finally, we averaged the results over 10 different generated sensor network scenarios. Fig. 4 shows the graph of average delay for the simulation scenarios discussed above. The simulation was carried out for two different cases

where in case 1, the network is in wake-up mode throughout the simulation period. In this case, it is not necessary to use the RF signal to wake up the node. In case 2, the network is in sleep mode, where an event wakes up the sensor node and eventually intermediate nodes are woken up by the RF signal. We simulated this case by transmitting the RF signal continuously for a period of 1sec to wake up the nodes. As observed in case 1, the data packet reaches the sink node within negligible period as there is no overhead of waking up the nodes. But in case 2, as the number of hops to reach the sink increases, it takes a longer duration for a data packet to reach to sink as it includes the delay of waking the nodes. Therefore, we concluded that the average delay is purely proportional to the number of hops, which in turn is dependent on the distance between the sink and event generating source node. The major advantage of using this protocol in relaxed latency constrained application is the amount of energy saved since the network is in sleep mode till an event occurs.

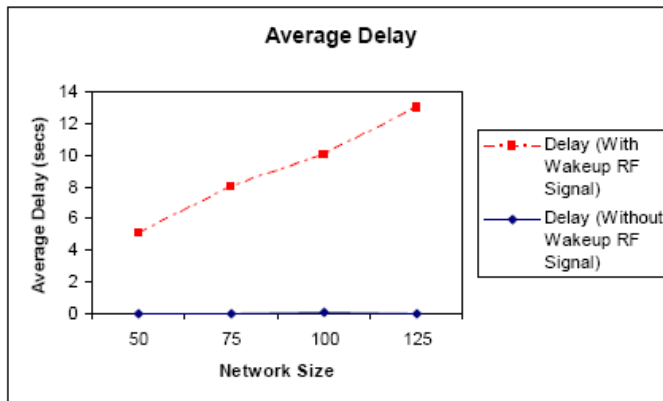

Fig. 4. Latency Time v/s Network Size

#### 4. Deployment challenges

Wireless Sensor Network is a very promising technology for monitoring and controlling large, remote and hostile areas. They are finding extensive application in the fields of home, industry, healthcare, agriculture and environment. Some of the reasons of its popularity are discussed below. The sensor nodes can acquire and analyze the measured data collected over vast distributed areas using multi-hop communication at lower wiring cost. Moreover, they can be deployed very quickly and easily without requiring any pre-existing infrastructure. They can even be integrated with existing external instruments in hostile areas to help collect, analyze and transmit data to the base station for control action. Lot of research is also going on in making the sensor nodes more energy efficient thereby increasing the lifetime of network deployment.

Although WSN is very useful technology for precise monitoring of large, remote and hostile areas, it suffers from some disadvantages. Researchers have now found the difference between the predicted and observed behaviour of the wireless sensor networks after deployment in the field. Some of the constraints and challenges involved in designing a WSN based system for any application are:

- Optimizing the size, power, cost and their associated tradeoffs
- Selection of network protocols that account for key realities in wireless communication
- Selection of real-time routing protocol (e.g RAP protocol, SPEED protocol)
- Selection of sensor network with limited processor bandwidth and less memory
- Improvement of communication range (Wark *et al.*, 2008)
- Design of sensor network with low power consumption for long term deployment. Much of the current research focuses on how to provide full or partial sensing coverage in the context of energy conservation. In such an approach, nodes are put into a dormant state as long as their neighbours can provide sensing coverage for them. In addition, attention has been drawn towards event based systems which account for power consumption.
- Selection of optimum OS for middleware is a critical aspect of WSN.
- Design for security: Sensor nodes are often deployed in accessible areas, presenting a risk of physical attacks. The key challenges are establishment, secrecy and authentication, privacy, robustness to denial-of-service attacks, secure routing, and node capture.

## 5. Energy harvesting techniques

WSN nodes being battery powered are designed to be energy efficient so as to maximize the lifetime of deployment. Apart from the hardware design, substantial research has been done on designing energy-efficient networking protocols to maximize the lifetime of WSNs (Seah *et al.*, 2009, 2010). One of the major problems faced by WSNs is the lack of a reliable energy source. Most of the WSNs which are deployed are (primary) battery powered and they need replacement from time to time. Battery replacement might not be practically possible in many situations especially where the sensor nodes are embedded in structures and need to be installed for long duration so, there is a need of using rechargeable batteries which can be charged from time-to-time thus, continuously delivering power to the sensor nodes. The batteries can be charged from the mains but that would incur additional cost of wiring and cabling for each sensor node which might not be practically feasible. Therefore, different energy harvesting techniques are adopted to charge the batteries and make the nodes self sustainable.

Since the WSN nodes require low power, micro-scale energy harvesting techniques are used to extract power at low levels from the surroundings. Micro-scale energy harvesting systems are now coming up for producing self sustaining low power electronics which no longer depend on battery for their operation. These systems are capable of extracting milli-watts of power from sources like light energy, vibration energy, RF and thermal energy. Harnessing energy from these sources has always been a challenge as these sources tends to be intermittent and unregulated although being abundantly available. The energy which is extracted from these sources can be stored in a capacitor, super capacitor, or battery. (Kompis & Aliwell, 2008), gave a review of the different energy harvesting technologies that could be used for remote and wireless sensing along with the limitations associated with the energy sources. Table 3 summarizes the various sources used for micro-scale energy harvesting along with the power estimate which can be extracted from them (Raju, 2008).

Energy Source	Harvested Power Estimate
Light (photovoltaic)	10uW-10mW/cm <sup>2</sup>
Vibration/Motion	4uW-100uW/cm <sup>2</sup>
Temperature difference	25uW-10mW/cm <sup>2</sup>
RF	0.1uW-1uW/cm <sup>2</sup>

Table 3. Energy Sources and their Harvested Power Estimate

As seen from the table, light (photovoltaic), thermal and vibration/motion energy seem to be more promising sources for low power applications. On the other hand, energy harvested from RF is very small and is still under the development stage but it finds considerable application in wireless power transmission esp. for powering low power Wireless Sensor Networks (WSNs). We have used RF energy harvesting technique in our prototype. The choice of the energy source for a particular application largely depends on the location of deployment. This section describes two energy harvesting techniques which could be employed for powering WSN nodes, these are: solar energy harvesting and RF energy harvesting.

### 5.1 Photovoltaic harvesting system

In this method, ambient light energy is harnessed and converted into electrical energy with the help of solar cells. Solar cells are essentially semiconductor junctions. Solar cells work on the photovoltaic effect in which, the light incident on the solar cell generates electron-hole pairs on both sides of the junction, the generated electrons and hole then diffuse in the junction and are swept away by the electric field thereby, generating current. The conversion efficiency of the solar cells is quite low ~10-20%. Fig. 5 shows the general structure of a solar cell. The power output of the solar cell is DC and so can be directly used to power DC loads or can be used for battery charging applications. They can even be used to power AC loads with the help of an inverter. In addition to solar energy, with recent advancements, a large range of low power solar cells are now available which are capable of working in indoor environment i.e. under a fluorescent source.

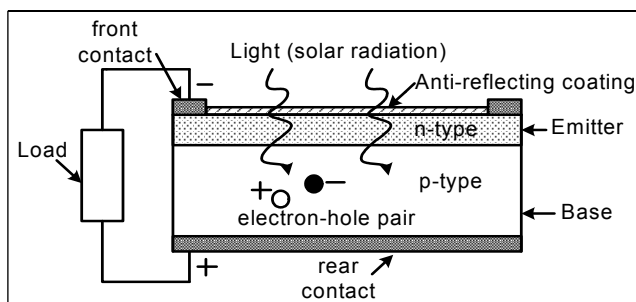

Fig. 5. General Structure of a Solar cell

*Advantages:* clean source, requires less maintenance, noise-less operation, flexible in configuration i.e. it can be easily connected in series or in parallel combination depending on the power requirement.

*Disadvantages:* power extracted is expensive due to high initial investment and low conversion efficiency, toxic chemicals like, cadmium and arsenic are used in the production



of solar cells which adversely impacts the environment, intermittent nature of the source in terms of power output.

*Applications:* low power solar cells find extensive application in calculators, portable lamps, watches, battery chargers, remote telemetry and communication.

## 5.2 RF Energy harvesting system

RF energy harvesting is the process by which energy is derived from external RF sources, (e.g., FM, TV Towers, Wi-Fi, Cell towers and Mobile phones etc.) captured and stored for different applications like in Wireless Sensor Networks(Seah et al., 2009, 2010) and Wearable electronics. In this method, RF energy harvesting receivers convert ambient energy (i.e. surrounding RF energy) into electricity. Receiver circuit consist of a rectenna i.e. a special type of antenna which directly converts RF energy into useful DC electricity (Mohammed et al., 2010) as shown in Fig. 6. In this case also, the power output is DC so it can be used to power DC loads or for battery charging applications.

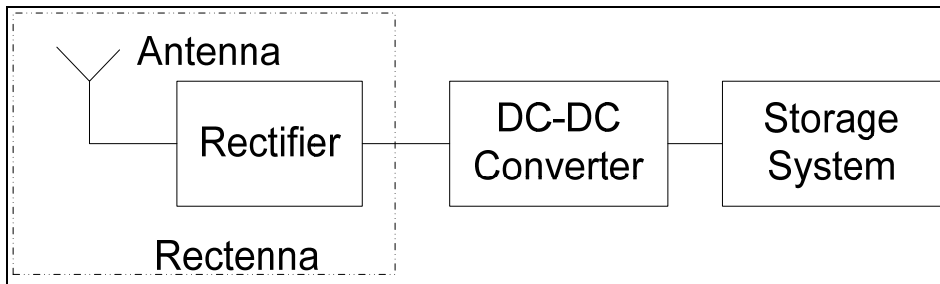

Fig. 6. General Block Diagram of RF Energy Harvesting Receiver System

*Advantages:* Power can be transferred to remote locations where wired power is not possible, controllable, and predictable. Power can even be transferred over long distances by proper system design.

*Disadvantages:* The amount of ambient energy captured is very small and irregular, so it can be used for powering very low power devices.

*Applications:* wireless sensor network, consumer electronics, industrial and transportation.

## 5.3 Photovoltaic harvesting system and its application in WSN

This section describes the solar photovoltaic harvesting system for low power application with the main focus being their application in WSNs. Nowadays, ultra low power solar cells are extensively finding applications in Wireless Sensor Networks (WSNs) deployed outdoors as well as indoors(Hande et al., 2007). The next sub-section describes the commercially available low power solar cells which can be used for such an application.

### 5.3.1 Solar cells (photovoltaic) for WSN

Solar photovoltaics are more popular in high power applications due to the fact that the high cost of the PV panel can be supported by such applications. However, with technological advancements, several low cost solar cells are now commercially available which can be used for WSN application esp. in industrial and hospital environment where indoor lights are operational continuously. Solar cells are available in crystalline silicon, thin

film and many other varieties with a trade off between cost and efficiency. Solar cells are available for illumination levels starting from 200 lux (under a fluorescent source) to 1000W/m<sup>2</sup> (under 1.5 solar spectrum). Typical voltage and current at maximum power point range between 1.2V-16V and 4uA-85mA respectively under different illumination conditions. The voltage per cell is low, so a number of cells are connected in series (stack) depending on the voltage requirement of the sensor node. The current requirement is met by connecting several such stacks in parallel. The overall cell configuration, acting as a single energy source can then be directly connected to the electronic device or through a charge storage device (like super capacitor, NiCad, NiMH, or Li rechargeable batteries) with charge controller system which limits overcharging of the batteries.

### 5.3.2 MPPT for maximum utilization of the source

The solar cell output is significantly affected by changes in the irradiation and temperature levels. Fig. 7 shows the current-voltage and power-voltage characteristic of the solar cell at particular irradiation and temperature level (Kumar, 2010). Since the current-voltage characteristic of a PV cell is non-linear, for a particular irradiation and temperature, there is a unique point on the power-voltage characteristic at which the photovoltaic power is maximum. This point is termed as the Maximum Power Point (MPP). The power, voltage and current corresponding to this point are referred to as  $P_{MPP}$  (power at maximum power point),  $V_{MPP}$  (voltage at maximum power point) and  $I_{MPP}$  (power at maximum power point) respectively. As the irradiation level changes, the power output of the PV system changes, which in turn, changes the MPP. Fig. 8 shows how the MPP points changes under different irradiation levels.

It is desirable to make the solar cell operate at MPP so that the source is utilized efficiently at all the times. This is made possible interfacing the solar cell with power electronic converter working as a Maximum Power Point Tracker (MPPT) incorporating one of the MPPT schemes. Various MPPT schemes for solar photovoltaic systems have been reported in literature (Faranda & Leva, 2008; Hohm & Ropp, 2000) with respect to their tracking speed and accuracy.

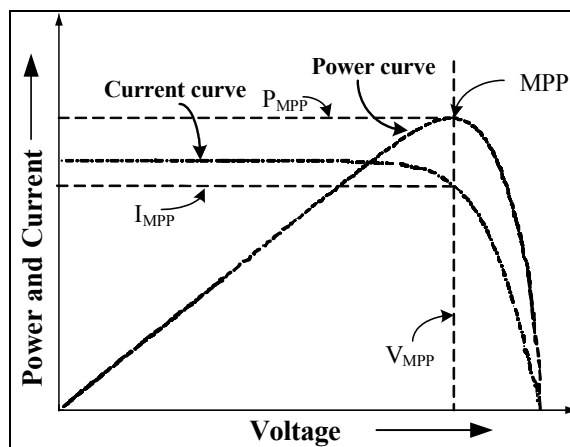

Fig. 7. Current-Voltage and Power-Voltage Characteristics of the Solar Cell

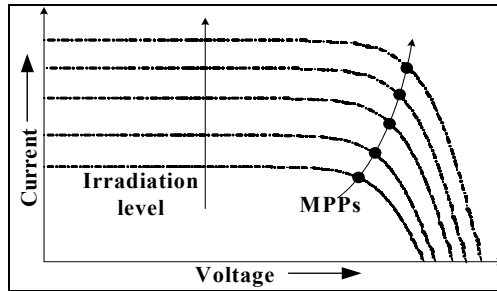

Fig. 8. Variation of MPP with the Variation in the Irradiation

### 5.3.3 Solar photovoltaic system for WSN application

Designing a power supply that involves, generation, storage and conversion is very challenging. A lot of problems are encountered both at the design level as well as at the implementation level and various solutions have been given by people to solve this problem (Mahlknecht & Roetzer, 2005). The solar photovoltaic harvester requirements change depending on the application at hand. A number of factors govern the power being delivered by the solar cell. Since they are employed to power WSNs deployed outdoors, the placement of sensors is one of the factors which play a major role. Best compromise of the placement position should be identified between the best illumination and location requirement. It should be ensured that the mounting place is not shadowed by the other objects and the place is sufficiently illuminated. Apart from the placement aspect, the radiation pattern of the location needs to be studied as it helps in the sizing of solar cell arrangement.

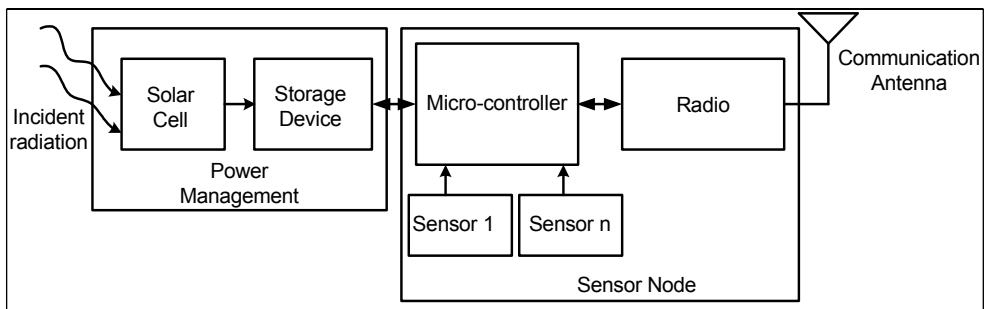

Fig. 9. Basic Block Diagram of a Solar Powered Wireless Sensor Node

The basic block diagram of solar powered wireless sensor node is given in Fig. 9. It typically consists of a power management unit, controller, sensors and radio transceiver. The power management unit comprises of the solar cell configuration (series/ parallel combination) and a storage element (capacitor/battery). The sizing of the solar cell configuration is done based on the power requirement of the wireless sensor node (RF Monolithics Application Note M1002, 2010). The storage element can be a super capacitor or battery or a combination of both with super capacitor providing the peak current and battery acting as the main back-up reservoir. Super capacitors are large capacitors available in the range of 50-100 Farad

with operating voltage of 2.6V. Several of these can be stacked up in series/parallel combination to supply the peak power demand. There are four types of rechargeable batteries which can be for this application, these are: Lead Acid, Nickel Cadmium, Nickel Metal Hydride and Lithium Ion. Of all these, Lithium Ion battery is most preferred to power WSNs because of its operating voltage of 3.6V. Lead Acid and Nickel Cadmium battery although being cheap and easily available are not popular due to increasing environment concerns about the lead and cadmium content.

The next block is the controller unit which processes the data obtained from the sensors connected to it and transmits the information using the radio transceiver. Some configurations might include MPPT device to effectively utilize the PV source. MPPT is popular in high power applications of solar photovoltaic where huge amount of energy is extracted. However, in low power applications, MPPT might add to power consumption and fail to be useful. Therefore, for low power applications demanding a constant output, the solar cell is interfaced with a power electronic converter. Power electronic converter works as a regulator/charge controller thereby helping the solar cell in meeting the constant load demand/charging the batteries. To conserve energy, WSNs operate in sleep mode, waking up at regular intervals to acquire process and transmit the sensor data to its neighboring devices/master system for decision making. The amount of current consumed by them in the sleep mode and wake up mode is of the order of 5 $\mu$ A and 200mA respectively. The current consumption and the time duration in each mode help in sizing the solar cell configuration for powering the sensor nodes. In addition to that, choice of battery and the depth of discharge also have an important role in determining the power requirement of the sensor node.

#### **5.4 RF energy harvesting system and its application in WSN**

This section describes the RF energy harvesting receiver system for low power application with the main focus being their application in low power WSN. However, another way of supplying power to sensor nodes is through wireless power transmission. Wireless Power Transmission (WPT) is transmission of electrical power from one point to another through vacuum or an atmosphere without use of wire any other substance. This can be used for applications where either an instantaneous amount or a continuous delivery of energy is needed, but where conventional wires are unaffordable, inconvenient, expensive, hazardous, unwanted or impossible.

Nicola Tesla who invented Radio, also known as "Father of Wireless" was the first who conceived the idea Wireless Power Transmission and demonstrated it in 1899. The idea behind this investigation was that, in recent years the use of wireless devices is growing in many applications like mobile phones, medical implants (Huang et al., 2008) or sensor networks. This increase in portable wireless applications has generated an increasing use of batteries. Many researchers are working on energy alternatives to reduce down their dependence on batteries and come up with low power counterparts so as to increase device lifetime. The charging of wired applications is still easy because the user can do it easily, like for mobile phones. But for other applications, like medical implants or wireless sensor nodes located in difficult access environments, the charging of the batteries remains a challenge. This requirement still increases when the number of devices is large and are distributed over a wide area or located in inaccessible places. Wireless Power Transmission (WPT) can be used as one solution to overcome the above mentioned limitations or challenges.

Different methods exist by which electrical energy can be transferred from the source to a load without the use of wire. These are: Electromagnetic Induction, Magnetic Resonance and Electromagnetic Radiation. Out of these, electromagnetic radiation is most popular for powering WSN nodes. The various RF sources and RF harvester design for the WSN nodes are discussed in the subsequent sections.

#### 5.4.1 RF energy sources

RF energy harvest method can be used to remotely charge the battery operated WSN device. The different categories of available RF sources (Kumar) which can be used for conversion are listed in Table 4. Along with the frequency range, the transmitted power for the various RF sources (transmitters) is also mentioned which can be captured and used for different low power applications.

RF Sources	Frequency Range	Tx Power
FM Tower	88-108MHz	10KW
TV Tower	180-220MHz	40KW
AM Tower	540-1600KHz	100KW
Wi-Fi	2.4-2.5GHz	10-100mW
Cell Tower	800,900,1800MHz	20W
Mobile Phones	GSM-900	2W
	GSM-1800	1W

Table 4. RF Energy Sources and their Harvested Power Estimate

When more power or continuous energy is required than what is available from ambient RF sources, RF energy can be broad casted in unlicensed frequency bands such as 868MHz, 915MHz, 2.4GHz and 5.8GHz. Each region has limitations on transmitted power like for e.g. its 4W in North America and 2W in Europe region.

#### 5.4.2 RF harvesting receiver system for WSN application

The basic block diagram of RF powered wireless sensor node is shown in Fig. 10. It typically consists of a energy harvesting unit, controller, sensors and radio transceiver. Apart from the energy harvesting unit, rest of the blocks remain the same for designing any WSN node as described in section 5.3.3. In any energy harvesting unit, mainly three components are required, these are: energy conversion, harvesting and conditioning and energy storage. Here, the energy harvesting unit (Hagerty et al., 2005) comprises of the rectenna (antenna + rectifier) and a storage element (capacitor/battery). The design of the rectenna is done based on the power requirement of the wireless sensor node.

Since the amount of useful energy obtained from RF is very less, reduction in energy consumption of system makes RF energy harvesting more practical. Researchers have come up with new solutions to improve the amount of energy being harvested from RF sources. In particular, circular polarized antennas are being implemented in the rectenna design because they avoid the directionality of other antenna designs (Strassner & Chang, 2003; Ali et al., 2005; Ren & Chang, 2006). An array of rectennas is now increasingly being used to improve the power output (Kim et al., 2006). Several new rectenna design schemes (Park et al., 2004; Chin et al., 2005) have been proposed by researchers. (Harrist, 2004), discussed

wireless battery charging using RF energy harvesting. A charging time of 4mV/sec was observed when mobile phone batteries were charged by capturing RF energy at 915MHz.

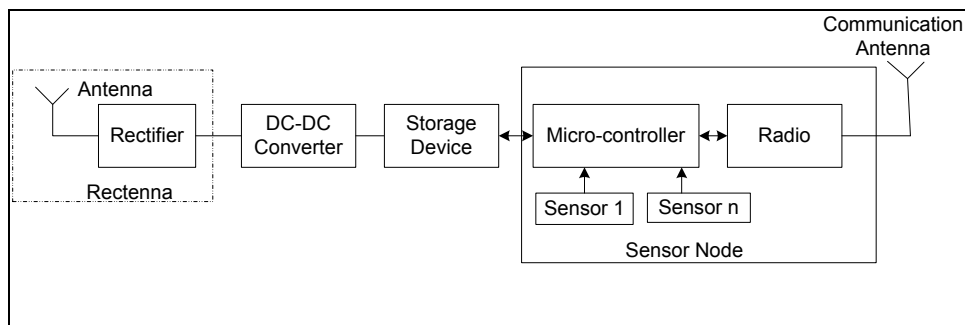

Fig. 10. Basic Block Diagram of RF Energy Harvested Sensor Node

## 6. Conclusion

This chapter discussed the aspects of using wireless sensor networks for forest tree monitoring and alerting using rare event detection with ultra low power consumption. In this prototype, two sensors (mercury sensor & temperature sensor) which work well for the detection of fire and tree theft were selected and mesh protocol was used for alert routing and event detection. Network lifetime and latency estimation for the deployment scenario showed the implementation feasibility of such a monitoring system for deforestation application. However, as the sensor nodes are battery powered, issues related to battery life and ease of battery replacement are major concerns for WSN applications that involve long term monitoring of vast area especially hostile areas. It is therefore necessary to have some means of recharging the batteries of the sensor node to increase the network lifetime. For this, one of the most common ways is to extract the energy from the surrounding environment. Life time of network is increased by adopting RF energy harvesting technique for recharging the sensor nodes. In addition to RF technique various other energy harvesting techniques are available that can be used for this purpose. The various energy sources which can be used for this prototype implementation have been explored here. A detailed description of solar and RF energy harvesting is given which can be used to charge the batteries and hence increase the lifetime of the deployed WSN system.

In future, the efforts can be taken to increase the robustness of the WSN setup in case of (a) self organization network, (b) failure of the sensor node (auto healing of sensor node) and (c) false alarms generated by sensor nodes.

## 7. References

- Ali, M., Yang, G., & Dougal, R. (2005). A New Circularly Polarized Rectenna for Wireless Power Transmission and Data Communication. *IEEE Propagation Letters on Antennas and Wireless*, ISSN: 1536-1225, Vol. 4, pp. 205-208, August 2005.

- Al-Turjman, F. M., Hassanein, H. S., & Ibnkahla, M. A. (2009). Connectivity Optimization for Wireless Sensor Networks Applied to Forest Monitoring. Proceedings of IEEE International Conference on Communications (ICC), ISBN: 978-1-4244-3435-0, pp. 1-6, Dresden, June 2009.
- Awang, A., & Suhaimi, M. H. (2007). RIMBAMON©: A Forest Monitoring System Using Wireless Sensor Networks. Proceedings of IEEE International Conference on Intelligent and Advanced Systems (ICIAS), ISBN: 978-1-4244-1355-3, pp. 1101-1106, Kuala Lumpur, November 2007.
- Bahrepour, M., Meratnia, N., & Havinga, P. (2008). Automatic Fire Detection: A Survey From Wireless Sensor Network Perspective. Centre for Telematics and Information Technology (CTIT), Technical Report TR-CTIT-08-73, ISSN 1381-3625, 13 Pages, December 2008.
- Bicket, J., Aguayo, D., Biswas, S., & Morris, R. (2005). Architecture and Evaluation of an Unplanned 802.11b Mesh Network. Proceedings of 11th annual International Conference on Mobile Computing and Networking (MobiCom), ISBN:1-59593-020-5, ACM Press, Germany, August 2005.
- Bischoff, R., Meyer, J., Enochsson, O., Feltrin, G., & Elfgren, L. (2009). Event-based strain monitoring on a railway bridge with a wireless sensor network. Proceedings of 4th International Conference on Structural Health Monitoring of Intelligent Infrastructure (SHMII-4), ISBN 978-3-905594-52-2, Zurich, Switzerland, July 2009.
- Bulusu, N., Heidemann, J., Estrin, D., & Tran, T. (2004). Self-configuring Localization Systems: Design and Experimental Evaluation. Journal of ACM Transactions on Embedded Computing Systems (TECS), Vol. 3, Issue 1, February 2004.
- Camp, J., Robinson, J., Steger, C. & Knightly, E. (2006). Measurement Driven Deployment of a Two-tier Urban Mesh Access Network. Proceedings of 4th International Conference on Mobile Systems, Applications and Services (MobiSys), ACM Press, Sweden, June 2006.
- Chin, C. H., Xue, Q., & Chan, C.H.(2005). Design of a 5.8 GHz Rectenna Incorporating a New patch Antenna. IEEE Propagation Letters on Antennas and Wireless, ISSN: 1536-1225, Vol. 4, pp. 175-178, June 2005.
- Eu, Z. A., Tan, H. P., & Seah, W. K. G. (2010). Wireless Sensor Networks Powered by Ambient Energy Harvesting: An Empirical Characterization. Proceedings of IEEE International Conference on Communications (ICC), ISBN: 978-1-4244-6402-9, pp. 1-5, May 2010.
- Faranda, R., & Leva, S. (2008). A Comparative Study of MPPT Techniques for PV Systems. Proceedings of 7th WSEAS International Conference on Application of Electrical Engineering, ISBN: 978-960-6766-80-0, 2008.
- Figueiredo, C. M. S., Nakamura, E. F., & Ribas, A. D. (2009). Assessing the Communication Performance of Wireless Sensor Networks in Rainforests', IEEE 2nd IFIP Wireless Days (WD), ISBN: 978-1-4244-5660-4, pp. 1-6, Paris, December 2009.
- Fonte, A., Zito, D., Neri, B., & Alimenti, F. (2007). Feasibility Study and Design of a Low-Cost System-on-a-Chip Microwave Radiometer on Silicon. Proceedings of IEEE International Conference on Waveform Diversity and Design, ISBN: 978-1-4244-1276-1, pp. 37-41, Pisa, June 2007.
- Gil, K. J., Prasetyo, R. B., Park, H. J., Lim, S. B., & Eo, Y. D. (2010). Fire Monitoring System based on Open Map API. Proceedings of 6th IEEE International Conference on

- Networked Computing and Advanced Information Management (NCM), ISBN: 978-1-4244-7671-8 , pp. 600-605, Seoul, August 2010.
- Hagerty, J. A., Zhao, T., Zane, R., & Popovic, R. (2005). Efficient Broadband RF Energy Harvesting for Wireless Sensors. Proceedings of Government Microcircuit Applications & Critical Technology Conference (GOMACTech), Las Vegas, NV, pp. 1-4, April 2005.
- Hande, A., Polk, T., Walker, W., & Bhatia, D. (2007). Indoor Solar Energy Harvesting for Sensor Network Router Nodes. Journal of Microprocessors and Microsystems, Elsevier Science Publishers, Vol. 31, No. 6, pp. 420-432, September 2007.
- Harrist, D. W. (2004). Wireless Battery Charging System using Radio Frequency Energy Harvesting. M.S. thesis, Department of Electrical Engineering, University of Pittsburgh, PA, 2004.
- Harvanová, V., Vojtko, M., Babiš, M., Ďuríček, M., Pohronská, M. (2011). Detection of Wood Logging Based on Sound Recognition Using Zigbee Sensor Network. Proceedings of International Conference on Design and Architectures for Signal and Image Processing, November 2011.
- Hefeeda, M., & Bagheri, M. (2007). Wireless Sensor Networks for Early Detection of Forest Fires. Proceedings of IEEE International Conference on Mobile Adhoc and Sensor Systems (MASS), ISBN: 978-1-4244-1455-0, pp. 1-6, Pisa, October 2007.
- Hohm, D. P., & Ropp, M. E. (2000). Comparative Study of Maximum Power Point Tracking Algorithms using an Experimental, Programmable, Maximum Power Point Tracking Test Bed. Proceedings of IEEE Photovoltaics Specialist Conference, ISBN: 0-7803-5772-8, pp. 1699-1702, Anchorage, AK, 2000.
- Huang, C-C., Yen, S-F., & Wang, C-C. (2008). A Li-ion Battery charging Design for Biomedical Implants. Proceedings of IEEE Asia Pacific Conference on Circuits and Systems (APCCAS), ISBN: 978-1-4244-2341-5, pp. 400-403, Macao, November 2008.
- Karlof, C. & Wagner, D. (2003). Secure Routing in Wireless Sensor Networks: Attacks and Countermeasures. Proceedings of the 1st IEEE International Workshop on Sensor Network Protocols and Applications, ISBN: 0-7803-7879-2, pp. 113-127, May 2003.
- Kim, J., Yang, S.Y., Song, K. D., Jones, S., & Choi, S.H. (2006). Performance Characterization of Flexible Dipole Rectennas for Smart Actuator Use. Smart Materials and Structures, Vol. 15, No. 3, pp. 809-815, 2006.
- Kompis, C., & Aliwell, S.(Editors). (2008). Energy Harvesting Technologies to Enable Remote and Wireless Sensing. Sensors and Instrumentation Knowledge Transfer Network Report, June 2008.
- Kovács, Z. G., Marosy, G. E., & Horváth, G. (2010). Case Study of a Simple, Low Power WSN Implementation for Forest Monitoring. Proceedings of 12th Biennial Baltic Electronics Conference (BEC), ISBN: 978-1-4244-7356-4, pp. 161-164, Tallinn, October 2010.
- Kumar, G. Radiation Hazards from Cell phones/Cell Towers. IIT Bombay.
- Kumar, K. (2010). Modelling, Design and Fabrication of Grid-connected Photovoltaic Systems. M. Tech. Thesis, Department of Reliability Engineering, IIT Bombay, India, July 2010.
- Lozano, C., & Rodriguez, O. (2010). Design of Forest Fire Early Detection System Using Wireless Sensor Networks. The Online Journal on Electronics and Electrical Engineering (OJEEE), Vol. 3, No. 2, Reference Number: W10-0097.



- Luming, F., Aijun, X., & Lihua, T. (2008). A Study of the Key Technology of Forest Fire Prevention Based on a Cooperation of Video Monitor and GIS. Proceedings of 4th IEEE International Conference on Natural Computation, ISBN: 978-0-7695-3304-9, pp. 391-396, Jinan, October 2008.
- Magrath, W. B., Grandalski, R. L., Stuckey, G. L., Vikanes, G. B., Wilkinson, G. R. (2007). Timber Theft Prevention: Introduction to Security for Forest Managers. Sustainable Development-East Asia and Pacific Region, Discussion Papers, The World Bank Publication, August 2007.
- Mahlknecht, S., & Roetzer, M. (2005). Energy Supply Considerations for Self-sustaining Wireless Sensor Networks. Proceedings of IEEE Second European Workshop on Wireless Sensor Networks, ISBN: 0-7803-8801-1, pp. 397-399, January 2005.
- Middleware for Sensor Networks, available at <http://lsir-swissex.epfl.ch/index.php/GSN:Home>
- Mohammed, S. S., Ramasamy, K., & Shanmuganatham, T. (2010). Wireless Power Transmission - A Next Generation Power Transmission System. International Journal of Computer Applications, ISBN: 978-93-80746-12-8, Vol 1, No.13, 2010.
- Park, J. Y., Han, S. M., & Itoh, T. (2004). A Rectenna Design with Harmonic-Rejecting Circular-Sector Antenna. IEEE Propagation Letters on Antennas and Wireless, ISSN: 1536-1225, Vol. 3, No. 1, pp. 52-54, December 2004.
- Powerharvester P1100 Module from Powercast, datasheet available at <http://powercastco.com/PDF/HarvesterDataSheetv2.pdf>
- Przydatek, B., Chan, H., Song D. & Perrig, A. (2007). SIA: Secure Information Aggregation in Sensor Networks. Journal on Computer Security-Special Issue on Security of Ad-hoc and Sensor Networks, Vol. 15, No. 1, ACM Press, January 2007.
- Raju, M., (2008). Energy Harvesting ULP meets energy harvesting: A game-changing combination for design engineers. Texas Instruments White Paper, 2008.
- Ren, Y. J., & Chang, K. (2006). 5.8 GHz Circularly Polarized Dual-Diode Rectenna and Rectenna Array for Microwave Power Transmission. IEEE Transactions on Microwave Theory and Techniques, ISSN: 0018-9480, Vol. 54, No. 4, pp. 1495-1502, April 2006.
- Rosi, A., Bicchieri, N., Castelli, G., Mamei, M., & Zambonelli, F. (2011). Landslide Monitoring with Sensor Networks: Experiences and Lessons Learnt from a Real-World Deployment. International Journal of Sensor Networks, Vol. 10, No. 3, pp.111-122.
- Seah, W. K. G., Eu Z. A., & Tan, H. P. (2009). Wireless Sensor Networks Powered by Ambient Energy Harvesting (WSN-HEAP) - Survey and Challenges. Proceedings of 1st IEEE International Conference on Wireless Communication, Vehicular Technology, Information Theory, Aerospace & Electronics Systems Technology (VITAE), ISBN: 978-1-4244-4066-5, pp. 1-5, Aalborg, May 2009.
- SensorMap, available at <http://atom.research.microsoft.com/sensewebv3/sensormap>
- SensorML, Sensor Model Language, available at <http://www.opengeospatial.org/standards/sensorml>
- Singh, S. K., Singh, M. P., & Singh, D. K. (2010). Routing Protocols in Wireless Sensor Networks - A Survey. International Journal of Computer Science & Engineering Survey (IJCSES), Vol.1, No.2, November 2010.
- Sizing, Solar Energy Harvesters for Wireless Sensor Networks. Application Note M1002, RF Monolithics, Inc., 2010.

- Soisoonthorn, T., & Rujipattanapong, S. (2007). Deforestation Detection Algorithm for Wireless Sensor Networks. Proceedings of IEEE International Symposium on Communication and Information Technologies (ISCIT), ISBN: 978-1-4244-0976-1, pp. 1413-1416, Sydney, December 2007.
- Strassner, B., & Chang, K. (2003). 5.8-GHz Circularly polarized dual-rhombic-loop traveling-wave rectifying antenna for low power-density wireless power transmission applications. IEEE Transactions on Microwave Theory and Techniques, ISSN: 0018-9480, Vol. 51, No. 5, pp. 1548-1553, May 2003.
- UCSD Active Campus available at <http://activecampus.ucsd.edu/>.
- Wang, G., Zhang, J., Li, W., Cui, D., & Jing, Y. (2010). A Forest Fire Monitoring System Based on GPRS and ZigBee Wireless Sensor Network. Proceedings of 5th IEEE Conference on Industrial Electronics and Applications (ICIEA), ISBN: 978-1-4244-5045-9, pp. 1859-1862, Taichung, June 2010.
- Wark, T., Hu, W., Corke, P., Hodge, J., Keto, A., Mackey, B., Foley, G., Sikka, P., & Br'uning, M. (2008). Springbrook: Challenges in Developing a Long-Term, Rainforest Wireless Sensor Network. Proceedings of IEEE International Conference on Intelligent Sensors Sensor Networks and Information Processing (ISSNIP), ISBN: 978-1-4244-3822-8, pp. 599-604, Sydney, December 2008.
- Zhang, J., Li, W., Yin, Z., Liu, S., & Guo, X. (2009). Forest Fire Detection System based on Wireless Sensor Network. Proceedings of 4th IEEE Conference on Industrial Electronics and Applications (ICIEA), ISBN: 978-1-4244-2799-4, pp. 520-523, Xian, May 2009.

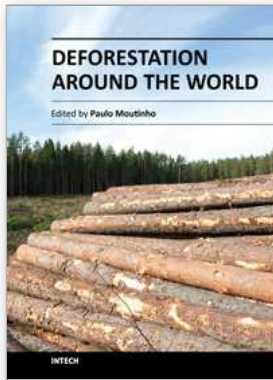

## **Deforestation Around the World**

Edited by Dr. Paulo Moutinho

ISBN 978-953-51-0417-9

Hard cover, 372 pages

**Publisher** InTech

**Published online** 30, March, 2012

**Published in print edition** March, 2012

Deforestation and forest degradation represent a significant fraction of the annual worldwide human-induced emission of greenhouse gases to the atmosphere, the main source of biodiversity losses and the destruction of millions of people's homes. Despite local/regional causes, its consequences are global. This book provides a general view about deforestation dynamics around the world, incorporating analyses of its causes, impacts and actions to prevent it. Its 17 Chapters, organized in three sections, refer to deforestation impacts on climate, soil, biodiversity and human population, but also describe several initiatives to prevent it. A special emphasis is given to different remote-sensing and mapping techniques that could be used as a source for decision-makers and society to promote forest conservation and control deforestation.

### **How to reference**

In order to correctly reference this scholarly work, feel free to copy and paste the following:

K.P. Chethan, Jayaraman Srinivasan, Kumar Kriti and Kaki Sivaji (2012). Sustainable Forest Management Techniques, Deforestation Around the World, Dr. Paulo Moutinho (Ed.), ISBN: 978-953-51-0417-9, InTech, Available from: <http://www.intechopen.com/books/deforestation-around-the-world/sustainable-techniques-to-prevent-the-deforestation->

**INTECH**  
open science | open minds

### **InTech Europe**

University Campus STeP Ri  
Slavka Krautzeka 83/A  
51000 Rijeka, Croatia  
Phone: +385 (51) 770 447  
Fax: +385 (51) 686 166  
[www.intechopen.com](http://www.intechopen.com)

### **InTech China**

Unit 405, Office Block, Hotel Equatorial Shanghai  
No.65, Yan An Road (West), Shanghai, 200040, China  
中国上海市延安西路65号上海国际贵都大饭店办公楼405单元  
Phone: +86-21-62489820  
Fax: +86-21-62489821

© 2012 The Author(s). Licensee IntechOpen. This is an open access article distributed under the terms of the [Creative Commons Attribution 3.0 License](#), which permits unrestricted use, distribution, and reproduction in any medium, provided the original work is properly cited.