

Parallel, Serial and Hybrid Machine Tools and Robotics Structures: Comparative Study on Optimum Kinematic Designs

Khalifa H. Harib¹, Kamal A.F. Moustafa¹,
A.M.M. Sharif Ullah² and Salah Zenieh³

¹*UAE University*

²*Kitami Institute of Technology*

³*Tawazun Holding*

^{1,3}*United Arab Emirates*

²*Japan*

1. Introduction

After their inception in the past two decades as possible alternatives to conventional Computer Numerical Controlled (CNC) machine tools structures that dominantly adapt serial structures, Parallel Kinematic Machines (PKM) were anticipated to form a basis for a new generation of future machining centers. However this hope quickly faded out as most problems associated with this type of structures still persist and could not be completely solved satisfactorily. This especially becomes more apparent in machining applications where accuracy, rigidity, dexterity and large workspace are important requirements. Although the PKMs possess superior mechanical characteristics to serial structures, particularly in terms of high rigidity, accuracy and dynamic response, however the PKMs have their own drawbacks including singularity problems, inconsistent dexterity, irregular workspace, and limited range of motion, particularly rotational motion.

To alleviate the PKMs' limitations, considerable research efforts were directed to solve these problems. Optimum design methods are among the various methods that are attempted to improve the dexterity as well as to maximize the workspace (Stoughton and Arai, 1993, Huang et al., 2000). Various methods to evaluate the workspace were suggested (Gosselin, 1990; Luh et al., 1996; Conti et al., 1998; Tsai et al., 2006). Workspace optimization is also addressed (Wang and Hsieh, 1998). A new shift in tackling the aforementioned problems came when researchers start to look at hybrid structures, consisting of parallel and serial linkages as a compromise to exploit the advantageous characteristics of the serial and parallel structures. This shift creates new research and development needs and founded new ideas.

Among the early hybrid kinematic designs, the Tricept was considered as the first commercially successful hybrid machine tools. This hybrid machine which was developed by Neos Robotics, has a three-degrees-of-freedom parallel kinematic structure and a

standard two-degrees-of-freedom wrist end-effector holding joint. The constraining passive leg of the machine has to bear the transmitted torque and moment between the moving platform and the base (Zhang and Gosselin, 2002). Recently the Exechon machine is introduced as an improvement over the Tricept design. The Exechon adopts a unique overconstrained structure, and it has been improved based on the success of the Tricept (Zoppi, et al., 2010, Bi and Jin, 2011). Nonetheless, regardless of the seemingly promising prospect of the hybrid kinematic structures, comprehensive study and understanding of the involved kinematics, dynamics and design of these structures are lacking. This paper is attempting to provide a comparative study and a formulation for the kinematic design of hybrid kinematic machines. The remainder of this paper is as follows: Section 2 provides a discussion on the mobility of serial, parallel and hybrid kinematic structures and the involved effects of overconstrain on the mobility of the mechanism. Section 3 provides a discussion on kinematic design for hybrid machines and the implication of the presented method. Concluding remarks are presented in Section 4.

2. Mobility of robotic structures

Mobility is a significant structural attribute of mechanisms assembled from a number of links and joints. It is also one of the most fundamental concepts in the kinematic and the dynamic modeling of mechanisms and robotic manipulators. IFToMM defines the mobility or the degree of freedom as the number of independent co-ordinates needed to define the configuration of a kinematic chain or mechanism (Gogu, 2005, Ionescu, 2003). Mobility, M , is used to verify the existence of a mechanism ($M > 0$), to indicate the number of independent parameters in the kinematic and the dynamic models and to determine the number of inputs needed to drive the mechanism.

The various methods proposed in the literature for mobility calculation of the closed loop mechanisms can be grouped in two categories (Ionescu, 2003): (a) approaches for mobility calculation based on setting up the kinematic constraint equations and their rank calculation for a given position of the mechanism with specific joint location, and (b) formulas for a quick calculation of mobility without need to develop the set of constraint equations. The approaches for mobility calculation based on setting up the kinematic constraint equations and their rank calculation are valid without exception. The major drawback of these approaches is that the mobility cannot be determined quickly without setting up the kinematic model of the mechanism. Usually this model is expressed by the closure equations that must be analyzed for dependency. There is no way to derive information about mechanism mobility without performing kinematic analysis by using analytical tools. For this reason, the real and practical value of these approaches is very limited in spite of their valuable theoretical foundations.

Many formulas based on approach (b) above have been proposed in the literature for the calculation of mechanisms' mobility. Many of these methods are reducible to the Chebychev-Grubler-Kutzbach's mobility formula given by Equation 1 below (Gogu, 2005). Using this formula, the mobility M of a linkage composed of L links connected with j joints can be determined from the following equation.

$$M = 6(L - 1 - j) + \sum_{i=1}^j f_i \quad (1)$$

where f_i is the DOF associated with joint i . Equation 1 is used to calculate the mobility of spatial robotic mechanisms as most industrial robots and machine tools structures are serial structures with open kinematics chains.

2.1 Mobility of planner mechanisms

To gain an insight into the effect of mobility on the kinematic analysis and design of serial, parallel and hybrid kinematic structures, we will also look at the mobility of planner mechanisms, which can be obtained from the following planner Kutzbach-Gruebler's equation (Gogu , 2005, Norton, 2004).

$$M = 3(L - 1 - j) + \sum_{i=1}^j f_i \tag{2}$$

where M , L , j and f_i are as defined before in Equation 1. As shown in Figure 1, the robotic structures are arranged in serial, parallel and hybrid kinematic chains, and thus have different number of links and joints. Using Equation 2, all the three structures in Figure 1 have three degrees of freedom, or mobility three. This gives the end-effector two translational degrees-of-freedom to position it arbitrarily in the x-y plane, and one rotational degree-of-freedom to orient it about the z-axis. In the serial kinematic structure all three joints are actuated, whereas for the parallel and hybrid structures only the three prismatic joints are actuated whereas the revolute joints are passive. The parallel kinematic part of the hybrid structure in Figure 1.c, has two degrees of freedom, which is achieved by reducing the number of legs to two and eliminating one of the passive revolute joints.

Figure 2 shows an alternative way to reduce the degrees of freedom of the parallel kinematic mechanism, and hence to reduce the number of actuated prismatic joints. In this example this is done by eliminating one of the revolute joints which connect the legs to the platform. The corresponding leg has a passive prismatic joint to constraint one of the degrees-of-freedom. By removing the revolute joint though the leg becomes a three-force member and hence it will be carrying bending moments necessitating considerable design attention to maintain desired stiffness levels and accuracy. This concept of reducing the degrees of freedom is adopted in the spatial Tricept mechanism to reduce the degrees-of-freedom from six to three. Compared to the mechanism in 1.c, this mechanism has more joints and links, which is not desirable from the design point of view.

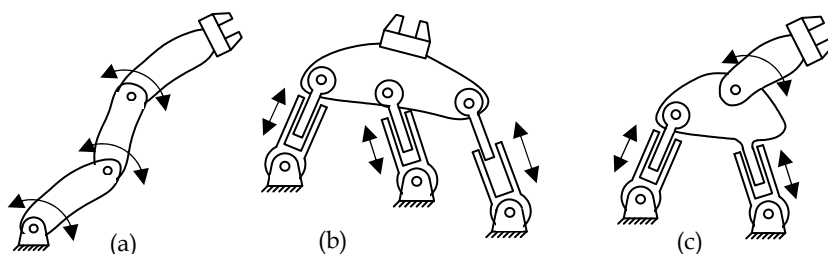

Fig. 1. Schematics of planner 3 degrees-of-freedom robotic structures with a) fully serial ($L=4, j=3, \sum f_i = 3$), b) fully parallel ($L=8, j=9, \sum f_i = 9$), and c) hybrid topologies ($L=6, j=6, \sum f_i = 6$)

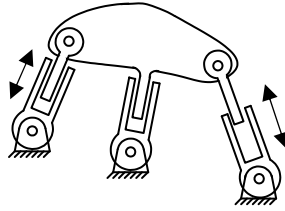

Fig. 2. Schematics of a 2-degrees-of-freedom parallel robotic structure, $L=7$, $j=8$, $\sum f_i=8$. The prismatic joint of the middle leg is passive (unactuated)

It should be noted here that the planner mechanisms are realized by necessitating that the involved revolute joints to be perpendicular to the plane and the prismatic joints to be confined to stay in the plane. As such these mechanisms can also be viewed as special cases of spatial mechanisms that are confined to work in a plane through overconstraints and thus Equation 1, with proper modification, rather than Equation 2 could be use, as discussed in the next section,

2.2 Over-constrained mechanisms

Formula for a quick calculation of mobility is an explicit relationship between structural parameters of the mechanism: the number of links and joints, the motion/constraint parameters of the joints and of the mechanism. Usually, these structural parameters are easily determined by inspection without a need to develop a set of kinematic constraint equations. However, not all known formulas for a quick calculation of mobility fit for many classical mechanisms and in particular parallel robotic manipulators (Ionescu, 2003). Special geometric conditions play a significant role in the determination of mobility of such mechanisms, which are called paradoxical mechanisms, or overconstrained, yet mobile linkage (Waldron and Kinzel, 1999). However, as mentioned above, there are overconstrained mechanisms that have full range mobility and therefore they are mechanisms even though they should be considered as rigid structures according to the mobility criterion (i.e. the mobility $M < 1$ as calculated from Equation 1. The mobility of such mechanisms is due to the existence of a particular set of geometric conditions between the mechanism joint axes that are called overconstraint conditions.

Overconstrained mechanisms have many appealing characteristics. Most of them are spatial mechanisms whose spatial kinematic characteristics make them good candidates in modern linkage designs where spatial motion is needed. Another advantage of overconstrained mechanisms is that they are mobile using fewer links and joints than it is expected.

In fact, the planner mechanisms in Figures 1 and 2 can also be viewed as overconstrained spatial mechanisms, and thus the spatial version of Kutzbach-Gruebler's equation (Equation 1), does not work for some of these planner mechanisms. In particular, for the parallel and hybrid kinematic planner mechanisms, Equation 1 will result in negative mobility values suggesting that these mechanisms are rigid structures, although they are not. Since this is

not true, it should be concluded that Equation 1 cannot be used for these over-constraint mechanisms (Mavroidis and Roth, 1995). The overconstraint in planner parallel and hybrid kinematic mechanisms is due to the geometrical requirement on the involved joint-axes in relation to each other. To solve the problem when using the spatial version of the Kutzbach-Gruebler's equation for planner mechanisms or for over-constraint mechanisms in general, Equation 1 has to be modified by adding a parameter reflecting the number of overconstraints existing in the mechanism (Cretu, 2007). The resulting equation is called the universal Somo-Malushev's mobility equation. For the case of mechanisms that do not involve any passive degrees of freedom it is written as

$$M = 6(L - 1 - j) + \sum_{i=1}^j f_i + s \quad (3)$$

where s is the number of overconstraint (geometrical) conditions. For example, the parallel kinematic mechanism in Figure 1.b has $L = 8$, $j = 9$, and $\sum f_i = 9$. Using these parameters in Equation 1 gives $M = -3$. However using Equation (3) and observing that there are 6 overconstraints in this mechanism, the mobility will amount to $M = 3$. The overconstraints in this mechanism are due to the necessity for confining the axes of the three prismatic joints to form a plane or parallel planes (two overconstraints), and for the axes of the three revolute joints of the moving platform (two overconstraints), and the three revolute joints of the base to be perpendicular to the plane formed by the prismatic joints.

3. Kinematic designs of robotic structures

A widely used kinematic design strategy for serial kinematic robotic structures to optimize the workspace is to use the first group of links and joints to position the end-effector and the remaining links and joints to orient the end-effector, and thus breaking the design problem into two main tasks. For the 6-DOF Puma robot schematic shown in Figure 3, the first three links and joint are responsible for positioning the end-effector at the desired position, while the last three joints and links form a 3-DOF concurrent wrist joint that orient the end-effector.

Conventional five axis machining centers achieve similar decoupling by splitting the five axes (three translational axes and two rotational axes) into two groups of axes. One group of serially connected axes is responsible for positioning/orienting the worktable which is holding the workpiece, while the other group of axes moves/orients the spindle (Bohez, 2002).

Unfortunately this strategy cannot be adopted for parallel kinematic structures due to the similarity of the legs and their way of working in parallel. As such decoupling of the two functions (positioning and orienting the end-effector) is not straightforward to do for parallel kinematic structures if not impossible. Partial decoupling has been attempted by Harib and Sharif Ullah (2008) using the axiomatic design approach.

On the other hand, it should be noted here that parallel structures, and to some extent hybrid structures, can be built from identical parts and modules, and thus lend themselves well to adaptation as reconfigurable machines (Zhang, 2006). This attribute is not strongly relevant to serial structures which consist of axes that are stacked on each other making the links and joints differ considerably in terms of size and shape.

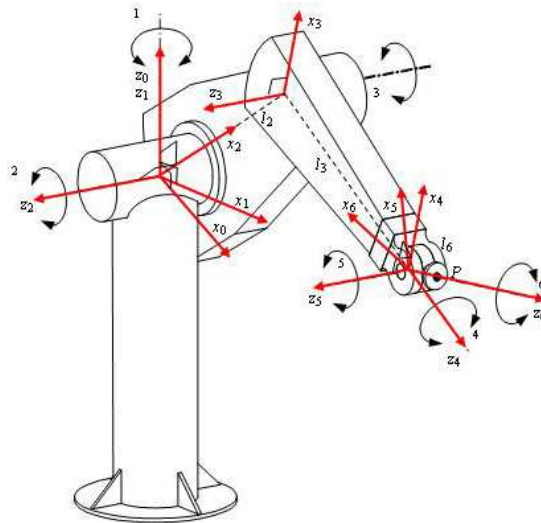

Fig. 3. A schematic of a 6-DOF Puma robot (serial kinematic structure)

3.1 Parallel kinematic designs

A main objective of the optimal design of parallel kinematic machines is to maintain consistent dexterity within the workable space of the machine. Dexterity of the mechanism is a measure of its ability to change its position and orientation arbitrarily, or to apply forces and torques in arbitrary directions. As such the Jacobian matrix of the mechanism is widely used in formulating the dexterity measure. For a six degrees-of-freedom hexapod mechanism (Harib and Srinivasan, 2003), shown in Figure 4, the Jacobian matrix J relates the translational and rotational velocity vectors of the moving platform to the extension rate of the legs as indicated below (Harib and Sharif Ullah, 2008).

$$[\dot{l}_1 \dots \dot{l}_6]^T = J_1 \dot{\mathbf{c}} + J_2 \boldsymbol{\omega} = \mathbf{J} \begin{bmatrix} \dot{\mathbf{c}}^T \\ \boldsymbol{\omega}^T \end{bmatrix}^T \tag{4}$$

where $\mathbf{J} = [J_1 \ J_2]$ is the Jacobian matrix of the hexapod, which consists of two 6×3 sub-matrices J_1 and J_2 that are given as

$$J_1 = [\mathbf{u}_1 \dots \mathbf{u}_6]^T \tag{5}$$

$$J_2 = [{}^M\mathbf{R}_C^C \mathbf{a}_1 \times \mathbf{u}_1 \dots {}^M\mathbf{R}_C^C \mathbf{a}_6 \times \mathbf{u}_6]^T \tag{6}$$

where \mathbf{u}_i and ${}^C\mathbf{a}_i$ are respectively a unit vector along the i th leg and the position vector of its attachment point to the moving platform in the platform coordinate frame C , and ${}^M\mathbf{R}_C$ is the rotational matrix of the moving platform. The Jacobian matrix \mathbf{J} relates also the external task space forces and torques and the joint space forces as indicated below.

$$[\mathbf{F} \ \mathbf{T}]^T = \mathbf{J}^T [f_1 \dots f_6]^T \tag{7}$$

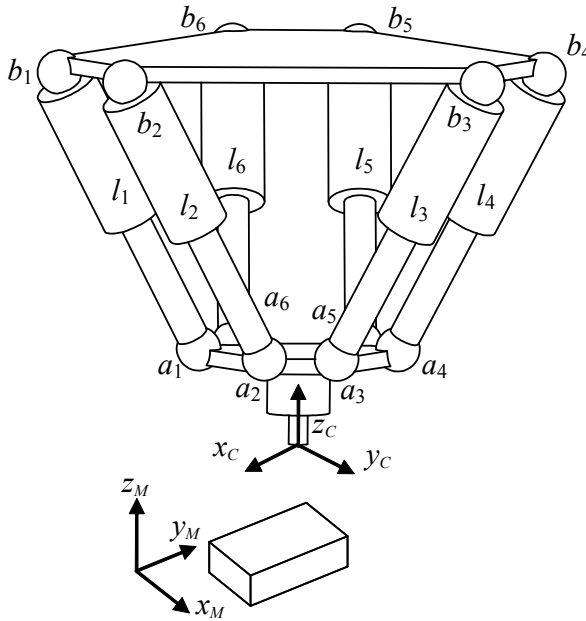

Fig. 4. Typical Construction of a hexapodic machine tools.

where \mathbf{F} and \mathbf{T} are respectively the resultants 3-D external force and torque systems applied to the movable platform. This result suggests that to support external force and torque along arbitrary directions, \mathbf{J}_1 and \mathbf{J}_2 must both have a rank three. Now to support these external force and torque resultants using bounded joint space forces, the condition numbers of \mathbf{J}_1 and \mathbf{J}_2 must be both as close to unity as possible.

An overall local performance measure PM can be obtained from the following relation

$$PM = w PM_1 + (1 - w) PM_2 \tag{8}$$

where w is a weighing factor in the range $[0 \dots 1]$ which signify how much emphases is given to translational and rotational dexterities, and PM_1 and PM_2 are respectively performance measures for the translational motion and the rotational motion of the structure, and are defined as (Harib and Sharif Ullah, 2008, Stoughton and Arai, 1993).

$$PM_1 = V' / \int_{V'} \kappa(\mathbf{J}_1) dV \tag{9}$$

$$PM_2 = V' / \int_{V'} \kappa(\mathbf{J}_2) dV \tag{10}$$

In the previous equations, $\kappa(\cdot)$ is the condition number function and V' is the workspace which is a subset of the total reachable space of the mechanism V . PM will then be in the

range $[0 \dots 1]$, with 1.0 corresponding to the best possible performance, which in turn corresponds to a perfectly conditioned Jacobian matrix.

The workspace of PKMs is another design issue that needs careful attention due to the computational complexity involved. Algorithms proposed in the literature to determine the workspace of PKM structures use the geometric constraints of the structures, including maximum/minimum leg lengths, passive joint limits. The complexity of these computational methods varies depending on the constraints imposed. For example if the cross sectional variation hexapod legs is also considered as a factor to avoid leg collisions considerable computational requirement will be necessary (Conti et. al, 1998). If the considered design would ensure that the operation of the machine is far enough from possibility of leg collisions in the first place considerable design efforts could be saved.

Harib and Sharif Ullah (2008) used the axiomatic design methodology (Suh, 1990) to analyze the kinematic design of PKM structures. In terms of the kinematic functions of PKM structures and based on the aforementioned contemplation, the following basic Functional Requirements (FRs) were identified: (1) The mechanism should be able to support arbitrary 3-D system of forces i.e. PM1 should be as close to unity as possible. (2) The mechanism should be able to support arbitrary 3-D systems of torques i.e. PM2 should be as close to unity as possible. (3) The mechanism should be able to move the cutting tool through a desired workspace. (4) The mechanism should be able to orient the spindle at a desired range within the desired workspace. On the other hand, to achieve the FRs the following two Design Parameters (DPs) are often used: (1) Determine the lengths and strokes of the legs. (2) Determine the orientation of the legs relative to the fixed base and to the moving platform in the home position. From the perspective of AD this implies that the kinematic design of hexapodic machine tools is sort of coupled design. Therefore, gradual decomposition of FRs and DPs are needed to make the system consistent with the AD.

Figure 5 shows a 2-DOF planar parallel kinematics structure. The structure includes two extendable legs with controllable leg lengths l_1 and l_2 and three revolute joints a_1 , a_2 , and c . The controlled extension of the two legs places the end-effectors point c at an arbitrary position (x, y) in the x - y plane.

The way the function requirements are fulfilled in this design is by assembling the mechanism such that the two legs are orthogonal to each other at the central position of the workspace as shown in Figure 5. This result is coherent with the isotropic configuration that could be obtained for this mechanism (Huang et al., 2004). Away from that position the mechanism is not expected to deviate much from this condition for practical configuration if the limits of the leg lengths are appropriately selected. It is clear that arbitrary strokes and average lengths of the two legs can be selected while maintaining leg orthogonally condition by adjusting the position of b_1 and b_2 .

The reachable space of the 2-DOF PKM of Figure 5 is bounded by four circular arc segments with radii l_{1-max} , l_{1-min} , l_{2-max} and l_{2-min} and centers b_1 and b_2 . With the two legs normal to each other the workspace can be modified along any of the two orthogonal directions independent from the other.

An extension of the previous design method to three DOF planner PKM structures is shown in Figure 6. Selecting the reference point of the mechanism to be the concurrent attachment point of the two orthogonal legs serves the purpose of showing the validity of the previously established result of uncoupled design in terms of the previously defined FRs and DPs. As indicated on Figure 6, with this choice of reference point, the same workspace of the 2-DOF structure is obtained.

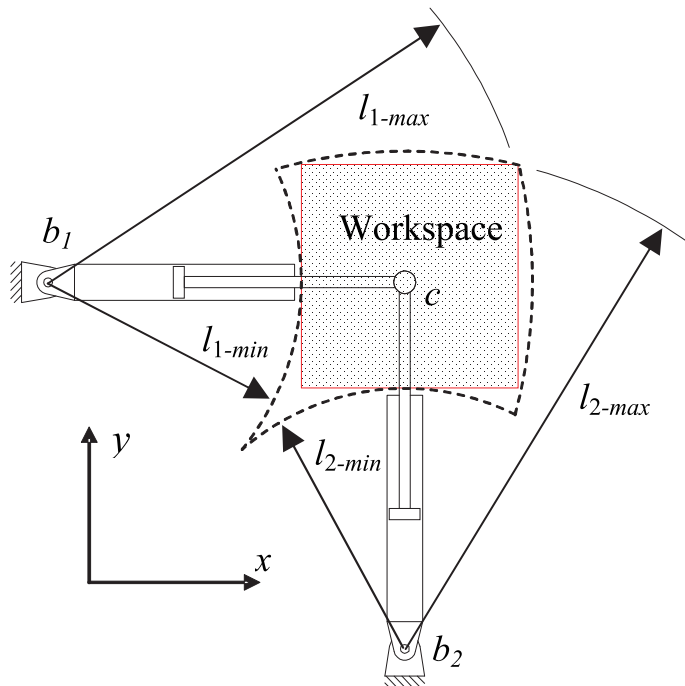

Fig. 5. A 2-DOF Planner PKM System (Harib and Sharif Ullah, 2008)

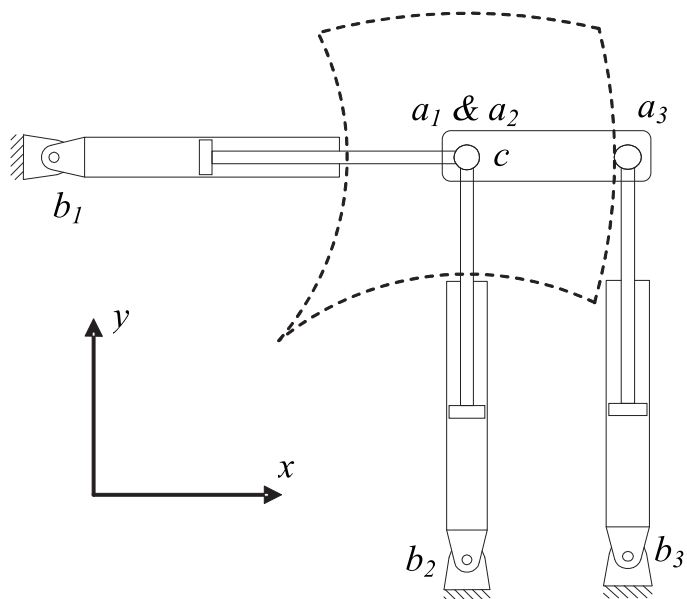

Fig. 6. A 3-DOF Planner PKM System (Harib and Sharif Ullah, 2008)

The previous 3-DOF PKM design of Figure 6 suggests extending the idea to a 6-DOF structure, as shown in Figure 7. The six legs of the suggested structure are arranged such that the idea remains the same (two parallel legs connected by a link and one orthogonal leg) in each of three mutually orthogonal planes. The purpose of the design is to support an arbitrary 6-DOF force and torque system.

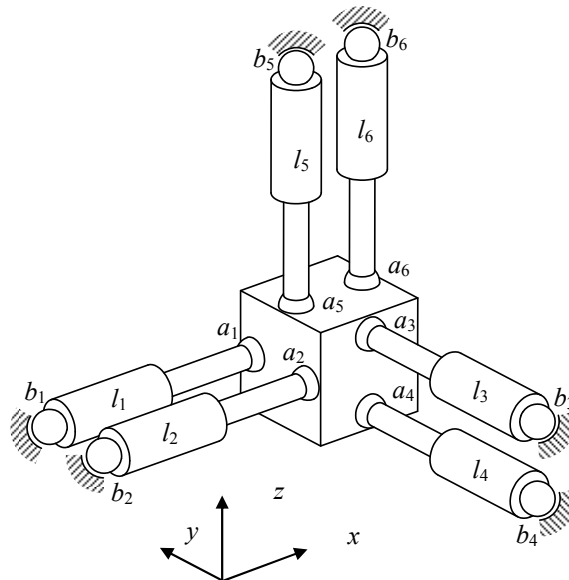

Fig. 7. A schematic of a 6-DOF spatial PKM (Harib and Sharif Ullah, 2008)

While the FRs' and DPs' of the axiomatic design methods are difficult to be decoupled here, this design of the 6 DOF mechanism is shown to be a logical extension from planner mechanisms designed with such design methodology.

3.2 Hybrid kinematic designs

Similar to the serial kinematic robotic design strategy, hybrid kinematic structures could be designed such the first three links and joints, forming the parallel structure, handle the gross positioning of the end-effector. The rest of joints and links could be made to form a concurrent serial kinematic structure that is responsible for orienting the end-effector. Thus this strategy decoupled two main functional requirements (FRs) of the mechanism and their design parameters (DPs). Now, while the serial kinematic part, which is responsible for the orientation of the end-effector, could be a standard wrist joint consisting concurrent revolute joints, the focus could now be directed on the design of the parallel kinematic part which still requires considerable design attention. The decoupling of the design requirements reduces the design problem to a design of a three-degrees-of-freedom parallel kinematic spatial structure that position the concurrent wrist joint along the x, y and z axes. Although the design requirements on the orientation are not part of the design requirements of the parallel part of the mechanism, ability to support a system of transmitted torque is still part of the design requirements. This is in addition to the requirements of having ability

to provide arbitrary motion along three directions and to support associated force system along these directions.

3.2.1 The Exechon mechanism

The Exechon machining center is based on a hybrid five degrees-of-freedom mechanism that consists of parallel and serial kinematic linkages (Zoppi et al., 2010). The parallel kinematic structure of the Exechon is an overconstrained mechanism with eight links and a total of nine joints; three prismatic joints with connectivity one, three revolute joints with connectivity one, and three universal joints with connectivity two. This mechanism is shown schematically in Figure 8.

The number of overconstraint (geometrical) conditions s is 3. These conditions require that the two prismatic joints l_1 and l_2 form a plane, and that the two axes of the joints a_1 and a_2 to be perpendicular to this plane, and the axis of joint a_3 be perpendicular to the axes of joints a_1 and a_2 . The parameters of the underlying mechanism can be identified as: $L = 8$, $j = 9$, $\sum f_i = 12$ for all the nine revolute, prismatic and universal joints. The mobility of this mechanism is erroneously calculated by Equation 1 as $M = 0$, which indicates that the mechanism is a structure. Nevertheless, if the geometrical constraints involved in this mechanism are considered and Equation 3 is applied, the mobility is correctly calculated as $M = 3$. These three degrees of freedom obviously correspond to the three actuating linear motors. The overconstraints in this mechanism considerably reduce the required joints, which obviously improves the rigidity of the mechanism. However, the geometric constraints that result in reducing the mobility to three require structural design for the joints to bear the transmitted bending moments and torque components. This requirement is more stringent in the case of the prismatic joints of the three legs. These legs will not be two-force members as in the six DOF hexapodic mechanism and have to be designed to hold bending moments.

The parallel kinematic part can be viewed as a 2-DOF planner mechanism formed by the two struts l_1 and l_2 and the platform, which could be revolved about an axis (the axes of the base joints b_1 and b_2 , shown as dashed line in Figure 8) via the actuation of the third strut l_3 . To achieve 2-DOF in the planner mechanism, three overconstraints are required. As indicated before these overconstraints come as requirements on the axes of the revolute joints a_1 and a_2 to be normal to the plane formed by l_1 and l_2 , and on the third revolute joint a_3 to be normal to the other two joints. Thus the projection of this strut onto the plane is constraining the rotational degree-of-freedom of the moving platform in the plane. This situation resembles the 2-DOF planner mechanism of Figure 2. When this projection onto the plane vanishes (i.e. when the angle between the third strut and the plane made by other two struts is 90 degree), the mechanism becomes singular (attains additional degree-of-freedom).

3.2.2 Alternative hybrid kinematic mechanism

In this section we demonstrate employing the Axiomatic Design to evaluate a potential design of a 5-axes alternative hybrid kinematic machine tools mechanism consisting of a 3-DOF parallel kinematic structure and a 2-DOF wrist joint. Axiomatic design is a structured design methodology which is developed to improve design activities by establishing criteria on which potential designs may be evaluated and enhanced (Suh, 1990). The general function requirements (FRs) for the proposed hybrid mechanism can be listed as follows. The mechanism should 1) provide required positioning and orientation capabilities, 2) have

adequate and consistent dexterity throughout the workspace, 3) have good structural rigidity, and 4) have a large and well shaped workspace. The design parameters (DPs) that could be used to achieve the function requirements concerning the parallel kinematic part of the mechanism include 1) the configuration of the wrist joint, 2) the configuration of the parallel kinematic mechanism, 3) the types of the end joints, and 4) the strokes and average lengths of the legs.

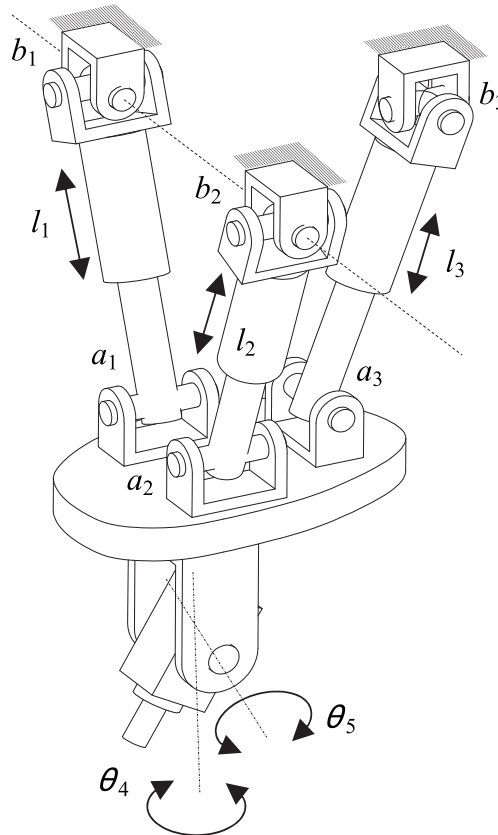

Fig. 8. A schematic of the Exechon hybrid kinematic machine tools mechanism

Based on the discussion in the previous sections and the axiomatic design formulation previously used for planner parallel kinematic structures (Harib and Sharif Ullah, 2008) a kinematic design of an alternative design for a hybrid kinematic machine tools mechanism is proposed. A schematic of the proposed mechanism is depicted in Figure 9 below. The parallel kinematic part has three perpendicular struts when the mechanism is at the center of the workspace, and consists of movable platform and three extendable struts. As shown in Figure 1, the first strut is rigidly connected to the platform, which in turn is connected to other two struts via revolute and universal joints. The struts are connected respectively to the machine frame via universal joints and a spherical joint with connectivity three. The number of overconstraint (geometrical) conditions s is 2. These conditions require that the

two prismatic joints l_1 and l_2 form a plane and that the axis of joint a_2 to be perpendicular to this plane. Calculating the mobility using Equation 1 yields $M = 1$. However considering the overconstraints ($s = 2$), the mobility of the mechanism, as calculated by Equation 3, will be $M = 3$.

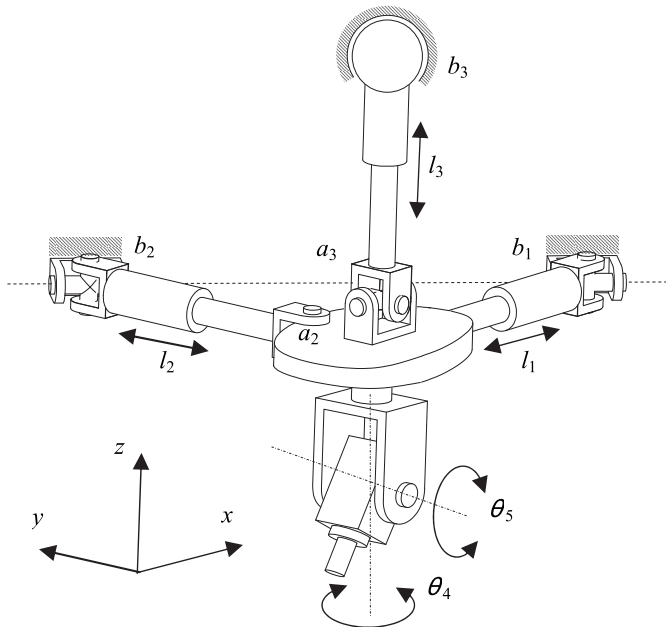

Fig. 9. A schematic of a proposed hybrid machine tools mechanism

In order to reach an optimum design, the Axiomatic Design FRs and DPs are grouped hierarchically. The design problem is also formulated such that the FRs are independent from each other (to fulfill the Independence Axiom), and the DPs are uncoupled at least partially (to fulfill the Information Axiom). Thus, the design strategy is directed to fulfill the FRs using uncoupled DPs first. Figure 10 shows main FRs for a hybrid kinematic mechanism design arranged hierarchically. The fundamental function requirement (FR1 = positioning and orientation capabilities) is split into two independent function requirements (FR11 and FR12) which can be addressed using independent design parameters. FR12 is split into three function requirements (FR121, FR122, FR123). For a given configuration of the parallel kinematic mechanism, the function requirements (FR121, FR122, FR123) can be addressed using the following design parameters:

DP121*i*: the type of the *i*th platform end joint a_i

DP122*i*: the type of the *i*th base end joint b_i

DP123*i*: the stroke of *i*th leg ($l_{i-max} - l_{i-min}$)

DP124*i*: average lengths of the *i*th leg $(l_{i-max} + l_{i-min})/2$

It is worth mentioning here that the joint axes resemble the five axes of the machine tools at the center of the workspace, and could be maintained to be close to this situation by proper

design and choice of the leg strokes and mean lengths. Also as an alternative configuration, the 2-DOF wrist joint that hold the spindle could also be replaced by a 2-DOF rotary table, transferring the relative rotational motion to the workpiece. A redundant hybrid structure consisting of a hexapod machine tools and a 2-DOF rotary table is suggested and analyzed by Harib et al. (2007).

4. Conclusions

The considerable interest that is shifted to hybrid kinematic structures to exploit the advantageous features of the serial and parallel kinematic structures and avoiding their drawbacks has brought about some interest in overconstrained hybrid mechanisms. A study on the mobility of the three classes of mechanisms is presented and focuses on the mobility of overconstrained structures in view of their application in parallel and hybrid structures to reduce the number of passive joints. The mobility of the Exechon mechanism is analyzed and discussed as an example of a successful machine tools mechanism. The study of this mechanism reveals that its 3-DOF parallel kinematic part is a revolving 2-DOF planner mechanism. Strategies for kinematic designs of planner parallel mechanisms were developed and discussed based on the axiomatic design methodology. Optimum configurations for planner mechanisms were presented for 2-DOF planner mechanisms and were shown to be extendable to 3-DOF planner and spatial mechanisms by proper choice of joints and constraints. An alternative optimum parallel and hybrid mechanism is discussed and analyzed.

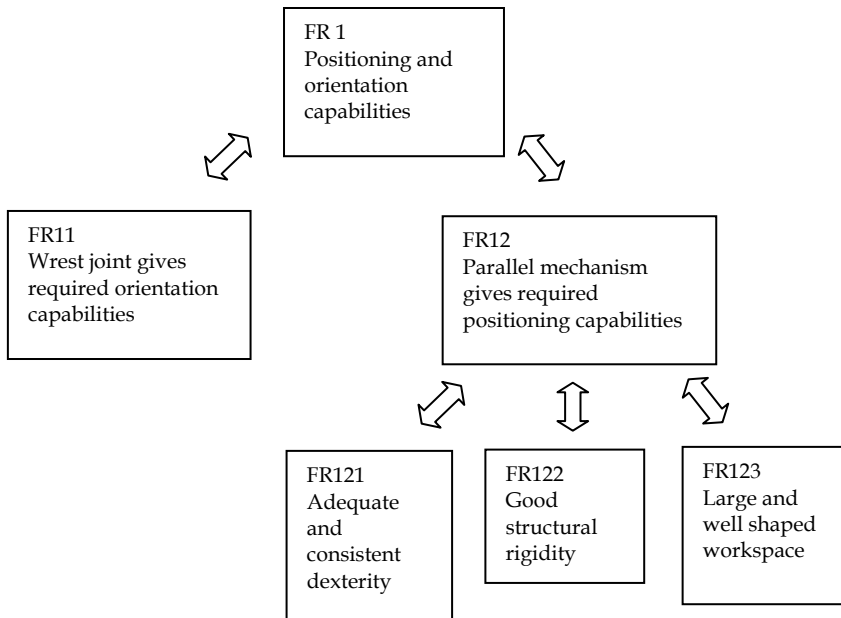

Fig. 10. Main Function Requirements of a hybrid design

5. Acknowledgment

The authors gratefully acknowledge the support of the Emirates Foundation (EF) under Grant No. 2008/052.

6. References

- Bi, Z.M., Jin, Y., (2011) Kinematic modeling of Exechon parallel kinematic machine, *Journal of Robotics and Computer-Integrated Manufacturing*, Vol. 27, Issue 1, February 2011, 186-193
- Bohez, E.L.J. (2002) Five-axis milling machine tool kinematic chain design and analysis *Int. Journal of Machine Tools & Manufacture* 42 Pages 505-520
- Cretu, S.M., (2007) TRIZ applied to establish mobility of some mechanisms," *Proceedings of the 12th IFToMM World Congress, Besancon, France, 18-21 June*
- Conti, J.P. Clinton, C.M., Zhang, G. and A. J. Wavering, A.J. (1998). *Workspace Variation of a Hexapod Machine Tool*, NISTIR 6135, National Institute of Standards and Technology, Gaithersburg, MD, March 1998.
- Gogu, G., (2005) *Mobility of mechanisms: a critical review," Mechanism and Machine Theory*, Vol. 40, p. 1608-1097.
- Gosselin, C. (1990). *Determination of the Workspace of 6-DOF Parallel Manipulator*, *Journal of Applied Mechanical Design*, 112, 331-336
- Luh, C., Adkins, F. Haung, E. and Qiu, C. (1996). *Working Capability Analysis of Stewart Platform Manipulator*, *ASME Journal of Mechanical Design* 118, 220-227.
- Harib, K.H., Sharif Ullah, A.M.M. (2008), *Axiomatic Design of Hexapod-based Machine Tool Structures, Reliability and Robust Design in Automotive Engineering*, SAE/SP-2170: 331-337.
- Harib, K.H, Sharif Ullah, A.M.M. and Hammami, H. (2007). *A Hexapod-Based Machine Tool with Hybrid Structure: Kinematic Analysis and Trajectory Planning*, *International Journal of Machine Tools and Manufacture*, 47, 1426-1432
- Harib, K., Srinivasan, K. (2003) *Kinematic and Dynamic Analysis of Stewart Platform-Based Machine Tool Structures*, *Robotica*, 21, (5), 541-554
- Huang, T., Li, Li, A., Chetwynd, D.G. and Whitehouse, D.J. (2004). *Optimal Kinematic Design of 2-DOF Parallel Manipulators with Well-Shaped Workspace Bounded by a Specified Conditioning Index*, *IEEE Transactions on Robotics and Automation*, 20(3), 538-543
- Huang, T., Wang, J., Gosselin, C.M. and Whitehouse, D.J. (2000). *Kinematic Synthesis of Hexapods with Specified Orientation Capability and Well-Conditioned Dexterity*, *Journal of Manufacturing Processes*, 2 (1), 36-47.
- Ionescu T.G., (2003) *Terminology for mechanisms and machine science," Mechanism and Machine Theory*, Vol. 38, p. 7-10
- Mavroidis C. and Roth B. (1995) *Analysis of Overconstrained Mechanisms*, *Journal of Mechanical Design*, *Transactions of the ASME*, Vol. 117, pp. 69-74.
- Norton, R. L., (2004), *Design of Machinery*, McGraw Hill
- Stoughton, R. & Arai, T. (1993). *A Modified Stewart Platform Manipulator with Improved Dexterity*, *IEEE Trans Robotics and Automation*, 9 (2), pp. 166-173.
- Suh, N.P. (1990). *The Principles of Design*, New York: Oxford University Press.

- Tsai, K.Y. Lee, T.K. and Huang, K.D. (2006). Determining the workspace boundary of 6-DOF parallel manipulators, *Robotica*, 24(5), 605-611.
- Waldron, K.J. and Kinzel, G.L. (1999) *Kinematics, Dynamics, and Design of Machinery*, John Wiley & Sons
- Wang, L.-C.T. and Hsieh, J.-H. (1998). Extreme reaches and reachable workspace analysis of general parallel robotic manipulators, *Journal of Robotic Systems* 15(3), 145-159.
- Zhang, D., Gosselin, C.M.(2002) Kinetostatic Analysis and Design Optimization of the Tricept Machine Tool Family, *J. Manufacturing, Science and Engineering.*, August, Vol. 124, Issue 3, 725-733
- Zoppi, M., Zlatanov, D., and Molfino, R. (2010) Kinematics Analysis of the Exechon Tripod, ASME 2010 International Design Engineering Technical Conferences and Computers and Information in Engineering Conference (IDETC/CIE2010), August 15-18, Montreal, Quebec, Canada

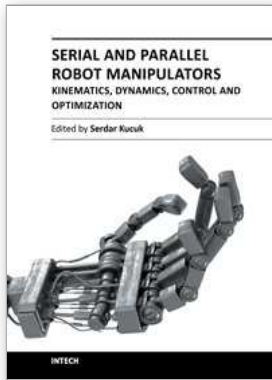

Serial and Parallel Robot Manipulators - Kinematics, Dynamics, Control and Optimization

Edited by Dr. Serdar Kucuk

ISBN 978-953-51-0437-7

Hard cover, 458 pages

Publisher InTech

Published online 30, March, 2012

Published in print edition March, 2012

The robotics is an important part of modern engineering and is related to a group of branches such as electric & electronics, computer, mathematics and mechanism design. The interest in robotics has been steadily increasing during the last decades. This concern has directly impacted the development of the novel theoretical research areas and products. This new book provides information about fundamental topics of serial and parallel manipulators such as kinematics & dynamics modeling, optimization, control algorithms and design strategies. I would like to thank all authors who have contributed the book chapters with their valuable novel ideas and current developments.

How to reference

In order to correctly reference this scholarly work, feel free to copy and paste the following:

Khalifa H. Harib, Kamal A.F. Moustafa, A.M.M. Sharif Ullah and Salah Zenieh (2012). Parallel, Serial and Hybrid Machine Tools and Robotics Structures: Comparative Study on Optimum Kinematic Designs, Serial and Parallel Robot Manipulators - Kinematics, Dynamics, Control and Optimization, Dr. Serdar Kucuk (Ed.), ISBN: 978-953-51-0437-7, InTech, Available from: <http://www.intechopen.com/books/serial-and-parallel-robot-manipulators-kinematics-dynamics-control-and-optimization/parallel-serial-and-hybrid-machine-tools-and-robotics-structures-comparative-study-on-optimum-kinema>

INTECH

open science | open minds

InTech Europe

University Campus STeP Ri
Slavka Krautzeka 83/A
51000 Rijeka, Croatia
Phone: +385 (51) 770 447
Fax: +385 (51) 686 166
www.intechopen.com

InTech China

Unit 405, Office Block, Hotel Equatorial Shanghai
No.65, Yan An Road (West), Shanghai, 200040, China
中国上海市延安西路65号上海国际贵都大饭店办公楼405单元
Phone: +86-21-62489820
Fax: +86-21-62489821

© 2012 The Author(s). Licensee IntechOpen. This is an open access article distributed under the terms of the [Creative Commons Attribution 3.0 License](#), which permits unrestricted use, distribution, and reproduction in any medium, provided the original work is properly cited.