

# Fuzzy Logic and Neuro-Fuzzy Networks for Environmental Hazard Assessment

Ignazio M. Mancini, Salvatore Masi,  
Donatella Caniani and Donata S. Lioi  
*Department of Engineering and Physics of the Environment,  
University of Basilicata,  
Italy*

## 1. Introduction

Pollution and management of the environment are serious problems which concern the entire planet; the main responsibility should be attributed to human activities that contribute significantly to damage the environment, leading to an imbalance of natural ecosystems. In recent years, numerous studies focused on the three environmental compartments: soil, water and air. The pollution of groundwater is a widespread problem. The causes of pollution are often linked to human activities, including waste disposal.

Solid waste management has become an important environmental issue in industrialized countries. The most serious problems are related to solid waste disposal. Landfill is still the most used disposal technique but not the safest. In fact, a breakdown of containment elements could easily occur even in controlled landfills. This breakdown could cause contamination of aquifer that is environmental pollution. Such contamination can be mitigated by performing remediation and environmental restoration. The assessment of environmental pollution risk can be performed with different degrees of detail and precision.

Various statistical and mathematical models can be used for a qualitative risk assessment. The planning of a program for environmental remediation and restoration can be supported by expeditious methodologies that allow us to obtain a hierarchical classification of contaminated sites. The literature offers some expeditious and qualitative methods including fuzzy logic (Zadeh, 1965), neural networks and neuro-fuzzy networks, which are more objective methods. The three artificial intelligence systems differ among themselves in some respects: fuzzy inference system learns knowledge of data only through the fuzzy rules; neural network is able to learn knowledge of data using the weights of synaptic connections; neuro-fuzzy systems are able to learn knowledge of neural data with neural paradigm and represent it in the form of fuzzy rules.

Fuzzy logic was founded in 1965 by Zadeh. The first applications date back to the nineties. They were mainly used to control industrial processes, household electrical appliances and means of transport. Later, this approach was used in several fields including the

environment. In fact, it could be used for assessing environmental risk related to contamination of groundwater. The fuzzy approach is advantageous because it allows us a quick assessment of the risk, but is disadvantageous because of the increasing complexity in the definition of fuzzy rules along with the increasing of the number of parameters. In many situations, when the number of parameters are considered high in the analysis, application of these techniques is cumbersome and complex and could be used for neuro-fuzzy models. These models reduce the complexity because they use training data. The neuro-fuzzy model was supported by a sensitivity analysis in order to address the problem of subjectivity and uncertainty of model input data.

### 1.1 Fuzzy logic

Fuzzy logic is a binary logic, which is inspired by Buddhist philosophy, which considers the world as something continuous. The fuzzy logic theory derives from the Persian-American engineer, Lotfi Zadeh, who theorized it in 1965 in an article entitled "Information and Control". In traditional logic, Aristotelian principles of non-contradiction and the excluded middle are valid. The principle of non-contradiction states that if  $X$  is a generic set and  $x$  a generic element, then  $x$  may belong to the whole  $X$  or not. The fuzzy systems deal with data and their manipulation with greater flexibility than traditional systems. The binary logic (or classical) is only concerned with what is completely true and, as a result, with what is completely false. Fuzzy logic instead extends its interest even to what is not completely true, what is probable or uncertain. The fuzzy logic is based on a linguistic approach, in which words or phrases of natural language are used instead of numbers. This approach simplifies complex situations and concepts which may use the traditional logic. In particular, the fuzzy logic operates on mathematical entities that are fuzzy sets. Fuzzy sets obey rules, structures and axioms which are very similar to those of classical sets; the difference is that an object can simultaneously belong to several subsets, in contrast to the classical theory. In the fuzzy world, membership to a subset is associated to a degree of membership. The set of deduction rules to be applied to a given system to achieve results through the use of fuzzy logic is defined the fuzzy inference process. Main phases of the fuzzy approach (Fig. 1) are the following: definition of membership functions, fuzzification, inference and fuzzy output.

Definition of membership functions is the main step on which all the other subsequent operations are based. Such functions, representing the fuzzy sets, can take different shapes (trapezoidal, triangular, Gaussian, etc.) according to the situations, and by convention can take values included between 0 and 1.

The fuzzification is the process by which input variables are converted to fuzzy measures belonging to certain classes such as Very Low, Low, Medium, High, Very High. This operation normalizes all the data in the interval [0-1]. In this way, comparisons between different amounts, measured in different scales are also possible.

The inference is the phase in which rules of combination of fuzzy sets are applied and it is possible to deduce a result. The rules are linguistic expressions that are translated into a mathematical formalism with the expression "if ... then" of the logic itself.

The output is a fuzzy membership value that can be used "pure" as a qualitative property or "defuzzified", as a real number compatible with non-fuzzy approaches (Silvert, 2000).

"Defuzzification" can be done using different methods, the most widely used one is the center of gravity, which calculates the center of gravity of the final fuzzy set and returns the value of abscissa.

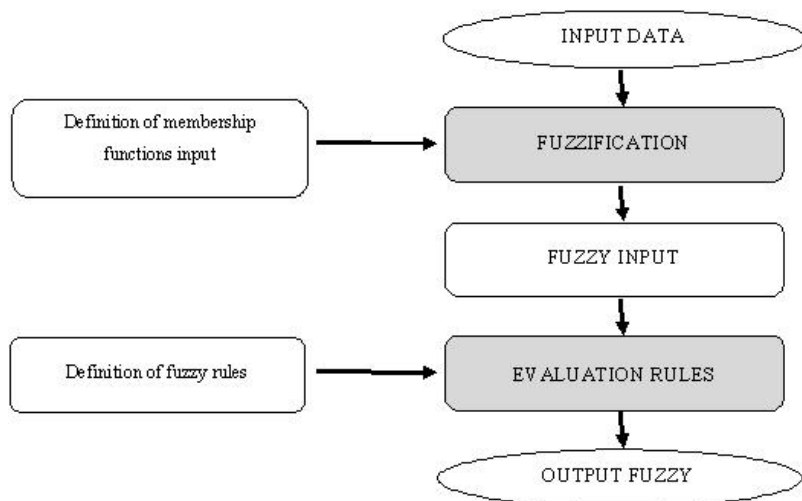

Fig. 1. Flow chart of the developed Fuzzy Inference System.

### 1.1.1 Fuzzification

Fuzzification is a procedure through which the input variables are turned into fuzzy measures of their membership to given classes. Such a conversion from deterministic sizes to fuzzy sizes is performed through the membership functions pre-set for those classes. A membership function (Fig.2) is a function which associates a value (usually numerical) with the level of membership to the set. By convention, the real number which represents the level of membership  $[\mu(x)]$  takes a 0 value when the element does not belong to the set, and 1 when it belongs to it completely.

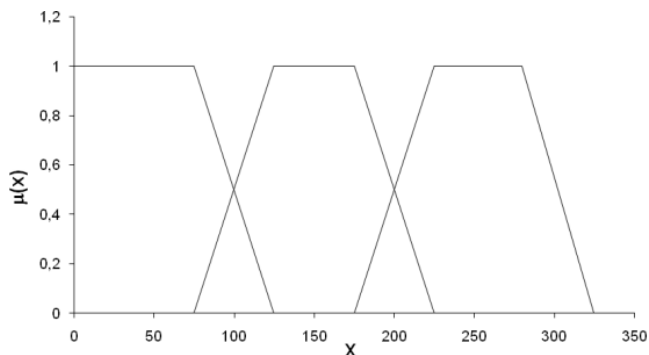

Fig. 2. Membership function.

Membership functions can be of several types: the simplest are made up of straight lines, while the most used are the triangular (Fig. 3) and trapezoidal (Fig. 4) functions; the former are characterized by a triangular trend while the latter by a trapezoidal one. The advantage of these functions is in their simplicity. The triangular membership function depends on three scalar parameters  $a$ ,  $b$  and  $c$  and is given by the following expression:

$$f(x; a, b, c) = \max\left(\min\left(\frac{x-a}{b-a}, \frac{c-x}{c-b}\right), 0\right) \quad (1)$$

while the trapezoidal one depends on four scalar parameters ( $a$ ,  $b$ ,  $c$  and  $d$ ), as shown in the following formula:

$$f(x; a, b, c, d) = \max\left(\min\left(\frac{x-a}{b-a}, 1, \frac{d-x}{d-c}\right), 0\right) \quad (2)$$

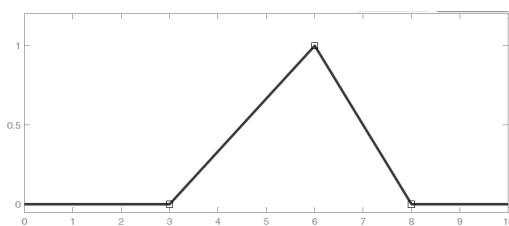

Fig. 3. Triangular membership function.

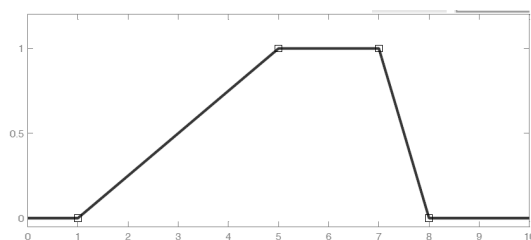

Fig. 4. Trapezoidal membership function.

There are other more complex functions, i.e. the Gauss function made up of a simple Gaussian curve (Fig. 5) which depends on parameters  $r$  and  $c$  (Eq. (3)); and the Gauss2 function (Fig. 6) given by the fusion of two different Gaussian functions and depending on four parameters:  $r_1$  and  $c_1$ , which define the shape of the function in the left part, and  $r_2$  e  $c_2$ , which define the shape of the function in the right part. Moreover, between these types of functions, there is the bell membership function (Gbell) (Fig. 7) which is a hybrid of the Gaussian function; it is mainly used to manage non-fuzzy sets and depends on three parameters:  $a$ ,  $b$  and  $c$  (Eq. (4))

$$f(x; \sigma, c) = e^{-\frac{(x-c)^2}{2\sigma^2}} \quad (3)$$

$$f(x;a,b,c) = \frac{1}{1 + \left| \frac{x-c}{a} \right|^{2b}} \tag{4}$$

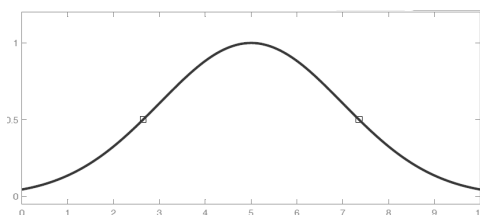

Fig. 5. Gauss membership function.

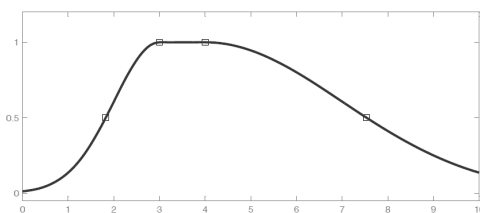

Fig. 6. Gauss2 membership function.

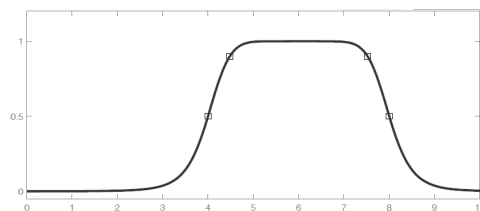

Fig. 7. Generalized bell (Gbell) membership function.

Despite their simplicity, such functions cannot be used to represent asymmetry, which is important in some applications.

In order to face a possible asymmetry, we can use another type of function, such as the sigmoid function (Fig. 8), which may have left or right asymmetry and a horizontal asymptote. This function is ruled by parameters  $a$  and  $c$  (Eq. (5))

$$f(x;a,c) = \frac{1}{1 + e^{-a(x-c)}} \tag{5}$$

In addition to this function, we have further asymmetric functions, the Dsigm and Psigm membership functions represented in Fig. 9 and 10 and described by Eq. (6), depending on four parameters  $a_1, c_1, a_2$  and  $c_2$ .

$$f(x;a,c) = \frac{1}{1 + e^{-a(x-c)}} \tag{6}$$

$$\left. \begin{array}{l} 1, x \leq a \\ 1 - 2 \left( \frac{x-a}{b-a} \right)^2, a \leq x \leq \frac{a+b}{2} \\ 2 \left( \frac{b-x}{b-a} \right), \frac{a+b}{2} \leq x \leq b \\ 0, x \geq b \end{array} \right\} \quad (7)$$

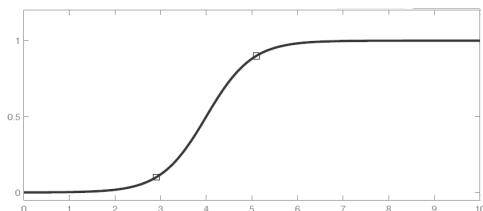

Fig. 8. Sigmoidale (Sig) membership function.

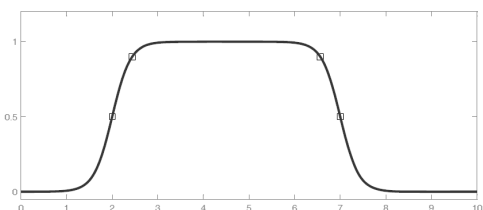

Fig. 9. Dsig membership function.

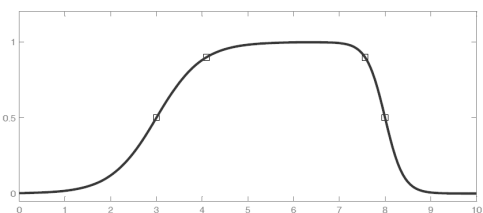

Fig. 10. Psig membership function.

Three more membership functions correlated with them are functions Z (Eq. (7)), S and Pi. The first one is an asymmetric function open to the left, the second is open to the right, while the third one is asymmetric but closed at both ends (Fig. 11-13).

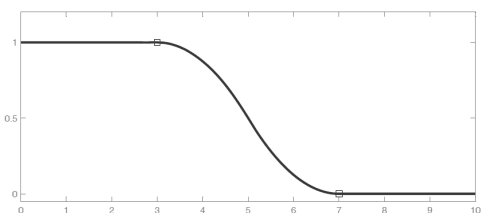

Fig. 11. Z membership function.

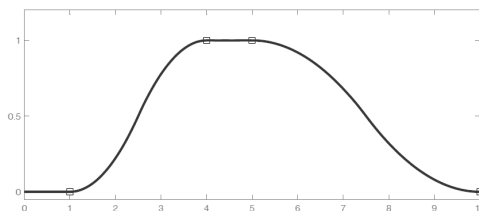

Fig. 12. Pi membership function.

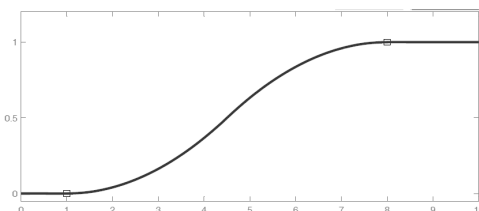

Fig. 13. S membership function.

### 1.1.2 Fuzzy inference

After the definition of the fuzzy data which comes from the fuzzification process, it is necessary to insert in the decisional engine the rules which supply the fuzzy output. The rules are usually made up of an if-then-else structure, which in its turn is made up of an antecedent which defines the conditions, and a consequent which defines the action. For each input variable of the model, in the antecedent we have a clause of the type ( $x$  is  $L$ ) where  $L$  is a linguistic label revealing a fuzzy set. In this way, the antecedent supplies a characterization of the condition of the system we want to model, namely its description in quantitative terms. Usually the antecedent includes a conjunction of clauses, one for each observed variable, while the condition of the consequent determines the condition of outputs.

In conclusion, a fuzzy system can be considered as a non-linear function which transforms a certain number of input variables into output ones through a set of fuzzy rules. In the application of rules, some of them often lead to the same consequence with different levels of strength: in these cases the common custom is choosing the highest value. Following this phase, which is defined fuzzy inference, it is necessary to turn the data coming from the evaluation of rules into real numerical data: this process is the opposite of input fuzzification, in fact it is called either output fuzzification or defuzzification.

### 1.1.3 Defuzzification

Defuzzification consists in drawing the output deterministic value from the fuzzy model. A careful analysis of the problem is at the basis of a correct defuzzification: it can be linguistic, when the output is a predicate to which a level of membership is associated, or numerical, of "crisp" type (non-fuzzy) (used in fuzzy control). Many criteria of defuzzification exist: often in engineering the choice depends on computational simplicity. The most used defuzzification methods are the following:

- Centroid method: the chosen numerical value for the output is calculated as the centre of mass of the fuzzy set.
- Bisector method: the output is the abscissa of the bisector of the area subtended to the fuzzy data set.
- Middle of maximum method: the output value is determined as the average of maximum values (Mom: middle of maximum).
- Largest of maximum method: the output numerical value is calculated as the maximum of the maximum (Lom: Largest of maximum).
- Smallest of maximum method: the output value is represented by the output minimum value (Som: Smallest of maximum).

Among the methods found in literature, the most common are the centroid and maximum methods.

In the middle of the maximum method, output is obtained as the arithmetic mean of the values of "y" where fuzzy set height is maximum.

B' is the fuzzy set inferred by rules and

$$hgt(B') = \left\{ y \mid \mu_{B'}(y) = \sup_{y \in B'} \mu_{B'}(y) \right\} \quad (8)$$

is the set value of "y" for which height " $\mu_{B'}(y)$ " is maximum.

Therefore, it has

$$y_{out} = \frac{\int_{hgt(B')} y dy}{\int_{hgt(B')} dy} \quad (9)$$

whose geometric significance is shown in Figure 14:

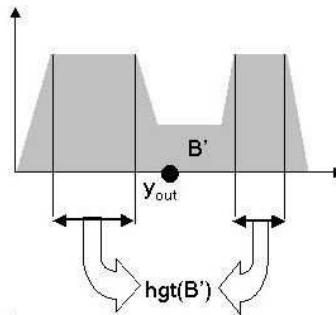

Fig. 14. Geometric significance of the Middle of maximum defuzzification method.

The output of the *Centroid method* is obtained as the abscissa of the center of gravity inferred from the rules in the space of fuzzy sets of algorithm output. The formula in the case of continuous function is:



$$y_{out} = \frac{\int y\mu(y)dy}{\int \mu(y)dy} \quad (10)$$

Whereas, the formula for discrete function is:

$$y_{out} = \frac{\sum_i y_i \mu(y_i)}{\sum_i \mu(y_i)} \quad (11)$$

In *Largest of maximum*, the precise value of the variable output is one of which the fuzzy subset has the maximum truth value. The main disadvantage of this method is that it does not consider the distribution of membership function.

However, the *smallest of maximum method* obtained the minimum value in fuzzy set as output.

## 2. Fuzzy neural network

The fuzzy neural network essentially fills the gaps in the fuzzy systems as well as other neurals. The fuzzy inference requires heuristics and does not acquire knowledge from input-output relationships as do neural networks. The advantage of a fuzzy neural network compared to a neural structure is that it can be represented by "linguistic rules". The nodes that form a neuro-fuzzy network have weights which do not commonly occur in a system based on a neural network. The network training is done using back-propagation algorithms. The Anfis models (Zimmermann 1991) acquire knowledge from data using algorithms typical of neural networks. This is represented using fuzzy rules. Substantially, neural networks are structured on different levels, starting from the input and output related systems which generate fuzzy rules that guide the process of construction output. As in fuzzy logic, the end result is linked to the fuzzy rules and membership functions. The membership functions can be of various types. The simplest consists of straight lines, while the most used functions are triangular and trapezoidal. There are more complex functions such as the Gauss function which consists of a simple Gaussian curve and function Gauss2 formed by the merger of two different Gaussian functions. In addition, among the functions of this kind, there is a bell membership function (Gbell) which is a hybrid of Gaussian function, and is used primarily to manage non-fuzzy sets. In order to meet any asymmetry, other functions can be used, such as Dsigm, Psigm and Pi.

The scientific literature has various applications of fuzzy neural network from the classical management of Humanoid Robots that will replace humans in dangerous jobs in the medical field or in the field of services (Dusko Katic et al., 2003). The fuzzy neural network was also used in the study of time series of solar activity (Abdel-Fattah Attia et al., 2005), in the assessment of noise in the workplace (Zaheeruddin Garima, 2006) and many others.

### 2.1 Architecture of a neuro-fuzzy network

The proposed forecasting model for assessing the environmental risk of contamination of aquifers is based on an Adaptive Neural Network Fuzzy Inference System (ANFIS)

(Zimmermann 1991; Jang, 1993). ANFIS algorithm allowed us to calibrate membership functions of the fuzzy inference training the Artificial Neural Network. In order to perform the training, the definition of a matrix of input parameters, a single output value and the number of times (numbers interpolating the training matrix) was necessary.

However, ANFIS models acquire knowledge from data using the typical neural networks algorithms but represent it using fuzzy rules.

These kind of neural networks are basically structured on five different levels which autonomously generate systems of fuzzy rules that guide the process of construction of the outputs, starting from related inputs and outputs.

Each node of the first level integrates the membership function associated with the represented fuzzy term. Variables  $X_i$  are the linguistic variables that are associated with terms placed in the nodes ( $A_{11} = \text{Low}$ ,  $A_{21} = \text{High}$  etc.).

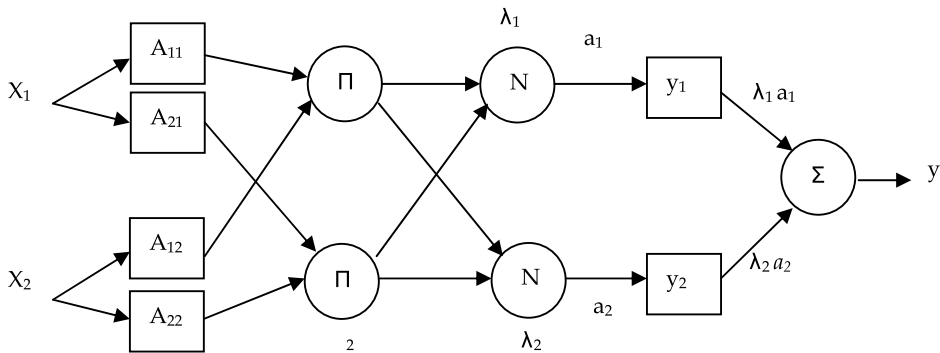

Fig. 15. Architecture of a neuro-fuzzy network.

Nodes of the second level incorporate the antecedents of fuzzy rules. Within these nodes, only an AND logical operation between the active inputs is performed.

In the third level, each node calculates the degree of fulfillment of each rule and returns a weighted term which enters as input in the corresponding node of the next level.

The nodes of this layer incorporate the resulting rules instead. Each node accepts the corresponding weight that comes from the previous level in input, in addition to all the input variables to the first level.

The fifth and last node simply performs the sum of all inputs and returns the final output of the system.

### 3 Case study

#### 3.1 Fuzzy and neuro-fuzzy models for groundwater pollution risk assessment

This study proposes two methods for environmental risk assessment: fuzzy logic and fuzzy-neural networks. Fuzzy and neuro-fuzzy models have been used to assess environmental risk in landfills, by using groundwater intrinsic vulnerability of landfill hazard (Fig. 17).

Groundwater intrinsic vulnerability has been assessed by a method of zoning for homogeneous areas: the GNDCI-CNR method (M. Civita, 1990). However, landfills hazard has been determined through the use of fuzzy logic and neuro-fuzzy parameters (input data) by considering morphological, hydrological and environmental parameters for each site, such as: water table depth, leachate production, volume and type of waste, landfill coverage, landfill activity and proximity to river. Some of these were obtained using GIS applications.

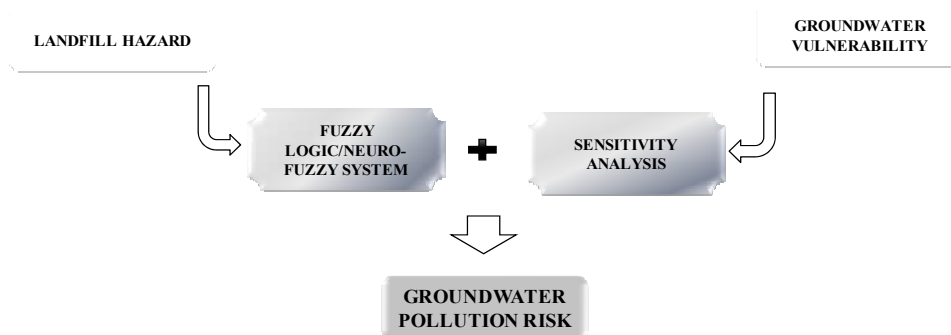

Fig. 16. Fuzzy and neuro-fuzzy models for the groundwater pollution risk.

For the simple management algorithm, the parameters previously indicated were used to define three different fuzzy inferences, as shown in the conceptual scheme in Figure 17. The results obtained through the first two fuzzy inferences, defined as *site vulnerability* and *landfill potentiality* respectively, were then aggregated to the crisp parameter called *landfill conditions*, by obtaining the hazard index of each landfill.

As shown in Figure 17, *site vulnerability*, defined through acclivity, depth to water table and watercourse proximity, allowed us to obtain the site's predisposition to suffer from contamination, namely the site's propensity to be contaminated because of a possible leachate seepage. The increase in vulnerability is favoured by low slopes, proximity to surface watercourses (meant as index, so the higher the index the higher the site vulnerability) and reduced depth of the water table. Thus, the values of the three parameters are low when the trend to undergo contamination is high. On the contrary, the *landfill potential* evaluates the potential of a landfill to release contaminants by virtue of the waste volume and the leachate production. Therefore, with the increase of these two factors such potential will increase. The procedure to determine the *landfill hazard index* combines the results obtained by the two previous fuzzy diagrams with the addition of the *landfill conditions*. The array of required training algorithm has been constructed, considering that the increase in values of the three parameters in the subset result in an increase in the hazard of landfills. The end result of the neuro-fuzzy process has been achieved through the training data which provided a numerical value between 0 and 1 representing the hazard index. In addition to training data that facilitates the definition of fuzzy rules, it is necessary to determine for each of the three fuzzy inferences the following: the type of membership function and the classes (very high, high, medium, low, very low). In conclusion, the results relating to site vulnerability, the landfill potential and the landfill hazard have been obtained.

Among the three output values for each landfill, our attention was mostly focused on the landfill hazard.

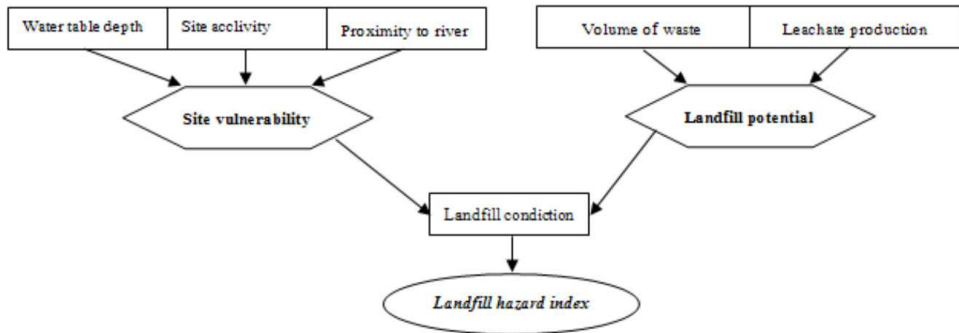

Fig. 17. Conceptual diagram of the implemented fuzzy model.

In addition, to address the risk of subjectivity and to overcome the problem of uncertainty, linked to input data and to the developed models, sensitivity analysis has been used, through which different fuzzy and neuro-fuzzy schemes have been compared. The various fuzzy schemes differ in the type of membership functions and defuzzification methods. Then, each fuzzy scheme is characterized by “if-then” fuzzy rules, membership functions and defuzzification method. The fuzzy rules have been defined considering that groundwater pollution risk rises with the increase of groundwater intrinsic vulnerability and landfill hazard.

However, the neuro-fuzzy schemes differ only in the type of membership functions, while the fuzzy rules are automatically generated by the algorithm using the assigned training matrix. The results obtained from the simulations of both models were compared with input data to identify the best fuzzy and neuro-fuzzy scheme.

The proposed algorithms have been applied to some uncontrolled landfills present in the Basilicata Region, detected through the 2002 census (“Corpo Forestale dello Stato [Forest Rangers]” and “Regional Reclamation Plan”), which identified 469 areas needing reclamation actions, environmental recovery and/or safety measures: 315 in the province of Potenza and 204 in the province of Matera. Among these areas, 290 are illegal landfills (Fig. 18): 122 in the province of Matera and 168 in the province of Potenza.

The comparison of each fuzzy and neuro-fuzzy scheme has been performed by applying statistical tests to the distributions of output data (environmental risk index). The results show that the best scheme for the fuzzy model is characterized by Gauss2 membership functions and Centroid defuzzification method, and the best scheme of neuro-fuzzy model is marked by Gauss membership function. The final results show the environmental risk index and have been recalculated for a classification of groundwater pollution risk in linguistic terms by using a cumulative frequency distribution curve (Fig. 19 and 20).

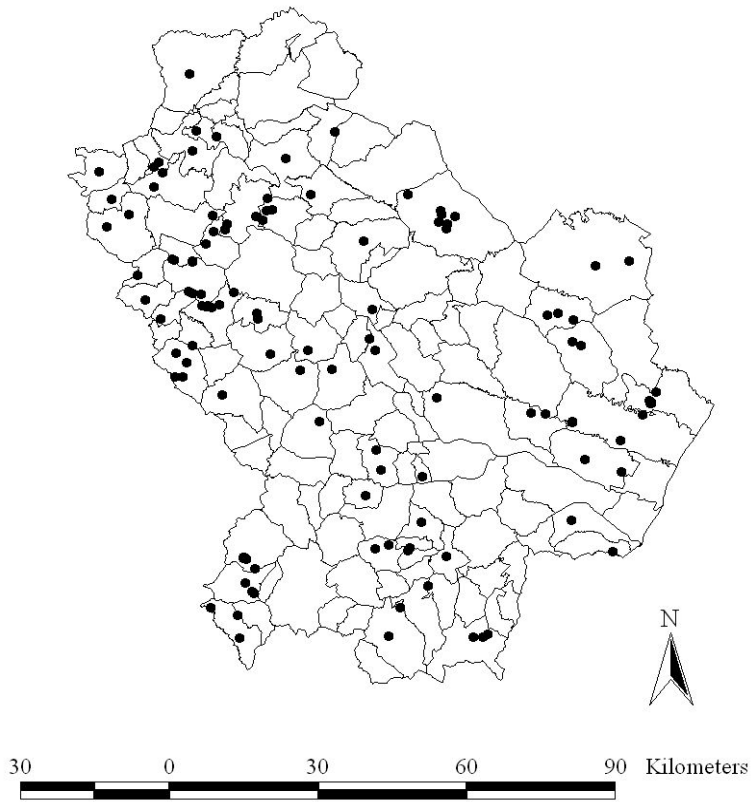

Fig. 18. Location of the uncontrolled landfills in the Basilicata Region.

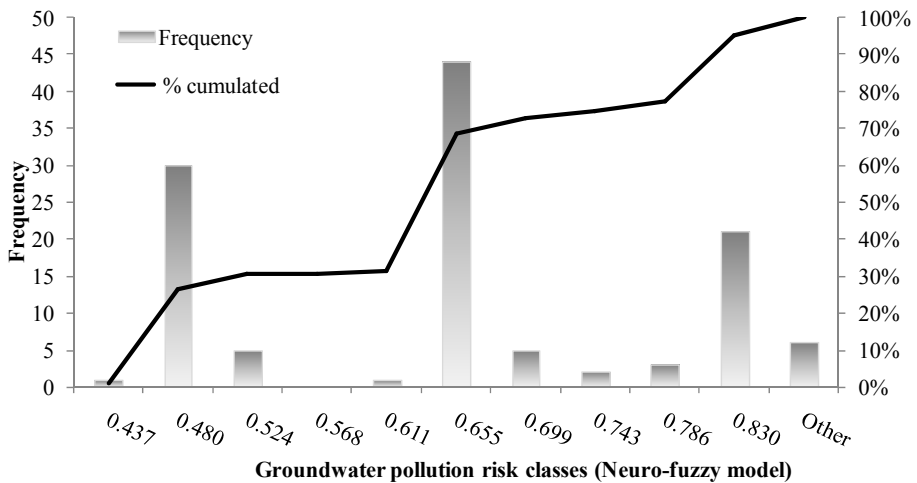

Fig. 19. Cumulated frequency curve of groundwater pollution risk for neuro-fuzzy model.

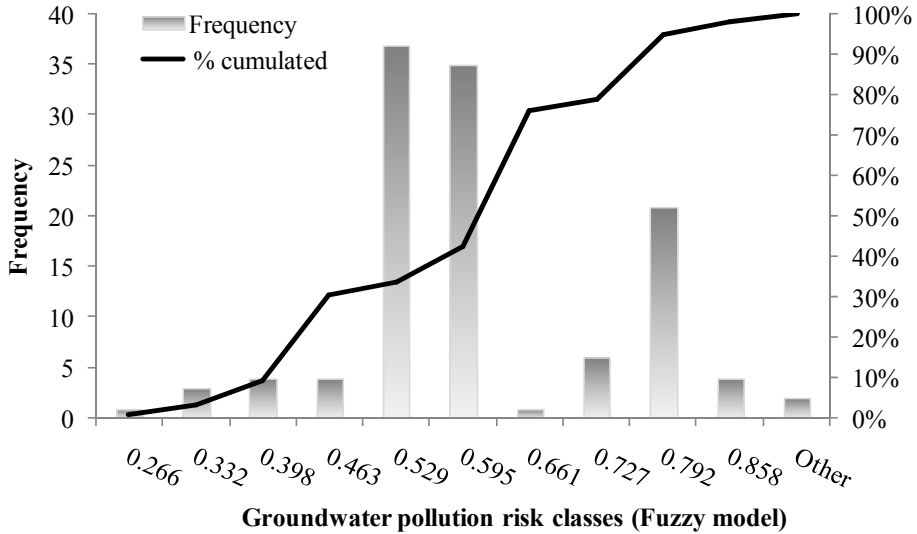
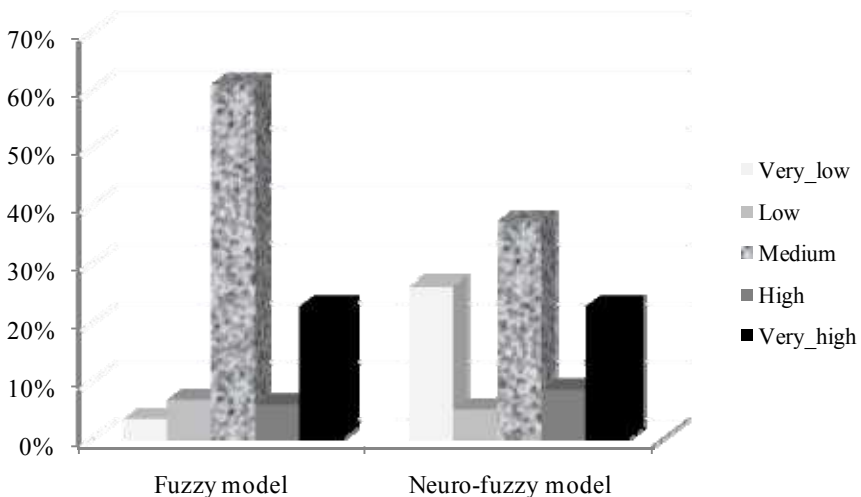

Fig. 20. Cumulated frequency curve of groundwater pollution risk for fuzzy model.

### 3.2 Comparison between environmental risk results obtained from the fuzzy and neuro-fuzzy models

The two designed models applied to some aquifers in Basilicata region have provided different results. For this reason, we next performed a statistical comparison. Visual analysis of histograms representing the percentage of aquifers falling in different classes of risk (fuzzy and neuro-fuzzy models) shows that distributions give different classes of risk (Fig. 21).



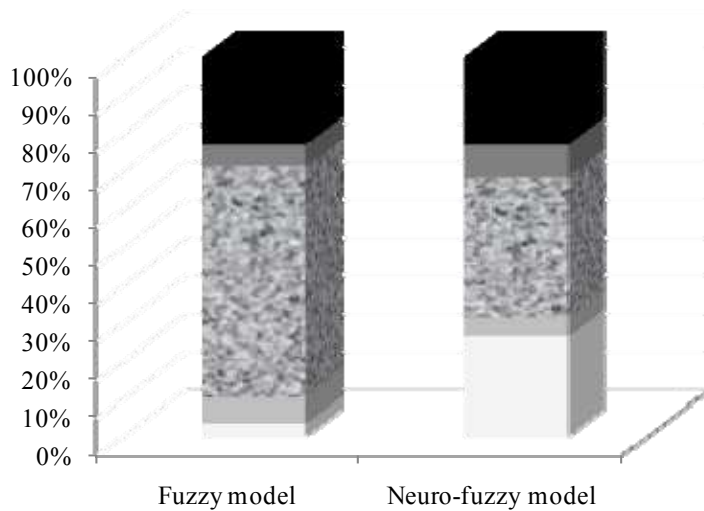

Fig. 21. Distributions of aquifers in classes of risk for fuzzy and neuro-fuzzy models.

We have evaluated the risk indices obtained from the two models for a more appropriate comparison. The assessment of the risk index without the subdivision into classes has demonstrated that the performance of the two distributions is very similar (Fig. 22) as confirmed by the box-plots (Fig. 23).

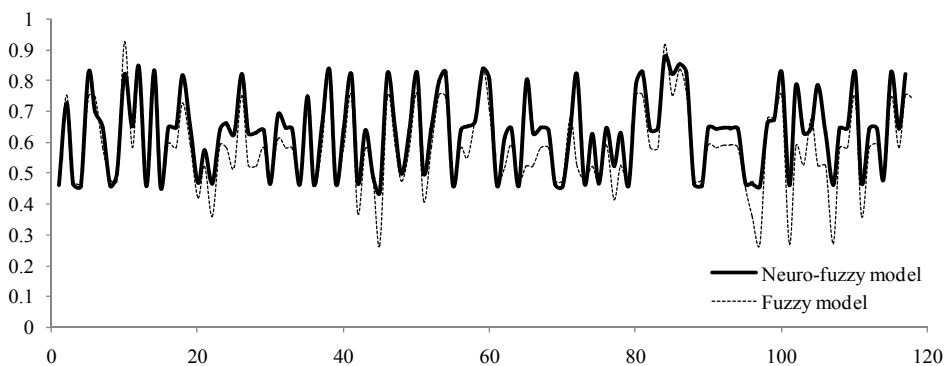

Fig. 22. Variation of the environmental risk index for each site.

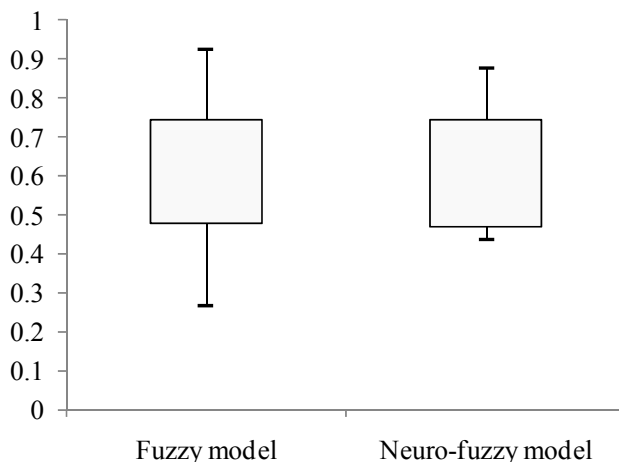

Fig. 23. Box-plots of the distributions of output data for fuzzy and neuro-fuzzy models.

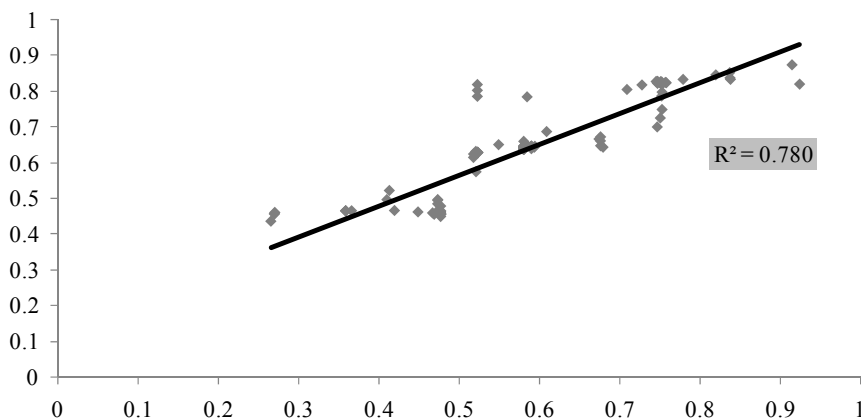

Fig. 24. Scatter plot between the environmental risk index obtained from the fuzzy and neuro-fuzzy models.

In fact, even the scatter plot (Fig. 24) shows a good correlation as evaluated by the coefficient of determination  $R^2$ , which is the square of the correlation coefficient  $R = 0.8832$ . Moreover, similarity between results of the two models can also be inferred from the comparison between variances and standard distributions and F test (Table 1).

	Environmental risk index (Fuzzy model)	Environmental risk index (Neuro-fuzzy model)
Standard deviation	0.136	0.133
Variance	0.018	0.018
F test	0.870	

Table 1. Statistical indices and test F results.



#### 4. Conclusion

The fuzzy and neuro-fuzzy approaches used for the realization of models of environmental risk assessment have been fast, effective and affordable methods and at the same time useful support for decisions. The neuro-fuzzy model is faster in the application because by using training data, it is able to generate the fuzzy rules, which are particularly complex and increases along with the number of parameters assigned to the model.

In addition, integration of sensitivity analysis in the two models is a positive element because it is able to mitigate the problems of subjectivity and arbitrariness of the evaluation based on fuzzy approaches commonly found in literature, in particular with regards to the choice of membership functions. The case study proposed, in fact, shows that by varying the choice of the membership functions very different results if not contradictory can be obtained.

In conclusion, a model can be substituted with the exception of the neuro-fuzzy model that is rapidly applicable in case you have data available for training a neuro-fuzzy network.

The fuzzy method is advantageous because it allows a rapid and efficient risk assessment and is an inexpensive and expeditious planning tool for a program of remediation. However, it is disadvantageous due to the complexity in the definition of fuzzy rules especially when the number of parameters is high. In fact, in many situations when the number of parameters of the analysis is high, the application of these techniques is cumbersome and complex; in these cases, neuro-fuzzy models, that reduce the complexity of the models thanks to the training data, could be used. Using the adaptive methods of fuzzy inference neural networks, you can easily manage fuzzy rules of the analysis and reduce the artifices of fuzzy and neural models (Iyatomi et al., 2004).

The use of this kind of analysis with respect to neural models does not provide very different results, as assessed and analyzed even by Vieira et al. in 2004, but only a different training time influenced by the order of the model.

#### 5. References

- Abdel-Fattah, Attia, Rabab, Abdel-Hamid, & Maha, Quassim (2005). Prediction of solar activity based on neuro-fuzzy modeling, *Solar Physics* 227: 177-191.
- Caniani, D., Lioi, D.S., Mancini, I.M., & Masi, S. (2011). Application of fuzzy logic and sensitivity analysis for soil contamination hazard classification. *Waste Management* 31 583-594.
- Civita, M.; (1990) *Legenda unificata per le Carte della vulnerabilità dei corpi idrici sotterranei/ Unified legend for the groundwater pollution vulnerability Maps. Studi sulla Vulnerabilità degli Acquiferi*, 1 Pitagora, Bologna
- Skarlatos, Dimitris, Karakasis, Kleomenis, & Trochidis, Athanassios, (2004) Railway wheel fault diagnosis using a fuzzy-logic method. *Applied Acoustics*, 65 (2004) 951-966.
- Duško, Katic, & Miomir, Vukobratovic (2003). Survey of Intelligent Control Techniques for Humanoid Robots. *Journal of Intelligent and Robotic Systems*, 37-117-141.
- Hitoshi, Iyatomi, & Masafumi, Hagiwara (2004). Adaptive fuzzy inference neural network. *Pattern Recognition* 37 2049-2057.

- Mei-qin, LIU, Sen-lin, Zhang, & Gang-feng, YAN, (2008). A new neural network model for the feedback stabilization of nonlinear systems, Liu et al. / J Zhejiang Univ Sci A 9(8):1015-1023.
- Miha, Mraz, (2001) The design of intelligent control of a kitchen refrigerator. *Mathematics and Computers in Simulation*, 56 259–267
- Saad, R., & Halgamuge, S. K., (2004). Stability of hierarchical fuzzy systems generated by Neuro-Fuzzy, *Soft Computing* 8 409–416.
- Saltelli, A., Chan, K., & Scott, E.M., (2000) Sensitivity analysis, Wiley & Sons
- Silvert, William, (2000) Fuzzy indices of environmental conditions. *Ecological Modelling* 130, 111–119.
- Van der Wal, A.J., (1995), Application of fuzzy logic control in industry. *Fuzzy Sets and Systems*, 74 33-41(1995).
- Vieira, José, Fernando, Morgado Dias, & Alexandre, Mota (2004). Artificial neural networks and neuro-fuzzy systems for modelling and controlling real systems: a comparative study, *Engineering Applications of Artificial Intelligence*, 17 265–273.
- Zadeh, L.A.; ( 1965) Information and control; *Fuzzy sets* 338-353 (1965).
- Zaheeruddi, Garima(2006). A neuro-fuzzy approach for prediction of human work efficiency in noisy environment. *Applied Soft Computing* 6 283-294.
- Zimmermann, H.-J. (1991). Fuzzy set theory and its applications, Dordrecht: Kluwer, second edition.

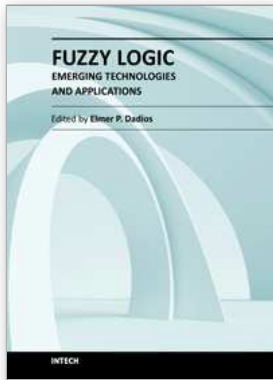

## **Fuzzy Logic - Emerging Technologies and Applications**

Edited by Prof. Elmer Dadios

ISBN 978-953-51-0337-0

Hard cover, 348 pages

**Publisher** InTech

**Published online** 16, March, 2012

**Published in print edition** March, 2012

The capability of Fuzzy Logic in the development of emerging technologies is introduced in this book. The book consists of sixteen chapters showing various applications in the field of Bioinformatics, Health, Security, Communications, Transportations, Financial Management, Energy and Environment Systems. This book is a major reference source for all those concerned with applied intelligent systems. The intended readers are researchers, engineers, medical practitioners, and graduate students interested in fuzzy logic systems.

### **How to reference**

In order to correctly reference this scholarly work, feel free to copy and paste the following:

Ignazio M. Mancini, Salvatore Masi, Donatella Caniani and Donata S. Lioi (2012). Fuzzy Logic and Neuro-Fuzzy Networks for Environmental Hazard Assessment, Fuzzy Logic - Emerging Technologies and Applications, Prof. Elmer Dadios (Ed.), ISBN: 978-953-51-0337-0, InTech, Available from: <http://www.intechopen.com/books/fuzzy-logic-emerging-technologies-and-applications/fuzzy-logic-and-neuro-fuzzy-networks-for-environmental-hazard-assessment>

# **INTECH**

open science | open minds

### **InTech Europe**

University Campus STeP Ri  
Slavka Krautzeka 83/A  
51000 Rijeka, Croatia  
Phone: +385 (51) 770 447  
Fax: +385 (51) 686 166  
[www.intechopen.com](http://www.intechopen.com)

### **InTech China**

Unit 405, Office Block, Hotel Equatorial Shanghai  
No.65, Yan An Road (West), Shanghai, 200040, China  
中国上海市延安西路65号上海国际贵都大饭店办公楼405单元  
Phone: +86-21-62489820  
Fax: +86-21-62489821

© 2012 The Author(s). Licensee IntechOpen. This is an open access article distributed under the terms of the [Creative Commons Attribution 3.0 License](#), which permits unrestricted use, distribution, and reproduction in any medium, provided the original work is properly cited.