

# Identification and Control of Multivariable Systems – Role of Relay Feedback

Rames C. Panda\* and V. Sujatha

*Department of Chemical Engineering, CLRI(CSIR), Adyar, Chennai, India*

## 1. Introduction

Batch and continuous systems are of multivariable in nature. A multivariable system is one in which one input not only affects its own outputs but also one or more other outputs in the plant. Multivariable processes are difficult to control due to the presence of the interactions. Increase in complexity and interactions between inputs and outputs yield degraded process behavior. Such processes are found in process industries as they arise from the design of plants that are subject to rigid product quality specifications, are more energy efficient, have more material integration, and have better environmental performance. Most of the unit operations in process industry require control over product rate and quality by adjusting one/more inputs to the process; thus making multivariable systems. For example, chemical reactors, distillation column, heat exchanger, fermenters are typical multivariable processes in industry. In case of chemical reactor, the output variables are product composition and temperature of reaction mass. The input variables are reactant or feed flow rate and energy added to the system by heating/ cooling through jackets. Product composition can be controlled by manipulating feed rate whereas rate of reaction (thereby temperature) can be controlled by changing addition/removal rate of energy. But, while controlling product composition, temperature is affected; similarly, while controlling temperature of reaction mass, the composition gets affected, thus, exhibiting interactions between input and output variables. Distillation is widely used for separating components from mixture in refineries. Composition of top and bottom products are controlled by adjusting energy input to the column. A common scheme is to use reflux flow to control top product composition whilst heat input is used to control bottom product composition. However, changes in reflux also affect bottom product composition and component fractions in the top product stream are also affected by changes in heat input. Hence, loop interactions occur in composition control of distillation column. Thus, unless proper precautions are taken in terms of control system design, loop interactions can cause performance degradation and instability. Control system design needs availability of linear models for the multivariable system. The basic and minimum process model for multivariable system is considered here as 2x2 system. The outputs of the loops are given by

---

\* Corresponding Author

$$\begin{aligned}y_1 &= u_1 G_{p11} + u_2 G_{p12} \\y_2 &= u_2 G_{p21} + u_2 G_{p22}\end{aligned}\quad (1)$$

where  $y_i$  are system outputs and  $u_i$  are the system inputs,  $G$  is system transfer functions. Eqn (1) can be expressed as  $y = G_p u$  where

$$y = [y_1 \ y_2]^T; \quad u = [u_1 \ u_2]^T; \quad G_p = \begin{bmatrix} G_{p11} & G_{p12} \\ G_{p21} & G_{p22} \end{bmatrix} \quad (2)$$

In order to achieve desired quality, specified output characteristics at the cost of spending optimum inputs one needs to design a controller and run the plant under closed loop so that optimal production of product under safe operation. The first thing we need is to select input-output pairs, i.e., which output should be controlled by which input? This needs knowledge in control structure selection or interaction analysis. In the next section, a brief state of art on interaction analysis is presented.

Relative gain array (RGA) (Bristol 1966) is the most discussed method for analyzing interactions and it is based on steady state gain information of MIMO processes. Control loops should have input-output pairs which give positive relative gains that have values which are as close as unity as possible. It is dependent on process models, independent of scaling of inputs and outputs and can include all ways of pairing in a single matrix. Niederlinski index (NI) is a useful tool to analyse interactions and stability of the control loop pairings determined using process gain matrix. NI is found by the following formula,

$$NI = \frac{|G_p|}{\prod_{i=1}^n g_{ii}} \Big|_{SS} \quad \text{where each element of } G_p \text{ is rational and is openloop stable. The values of}$$

NI need to be positive. A negative value of NI will imply that the system is un-stable. Ni is used to check if the system (more than 2x2) is unstable or not. NI will detect instability introduced by closing the other control loops. Generally, NI is not used for systems with time delays. Any loop pairing is unacceptable if it leads to a control system configuration for which the NI is negative. But both RGA & NI do not provide dynamic information on the process transients. They do not give information on change in in/op pairing for instances when there is a sudden load disturbance. Singular value decomposition (SVD) is a useful tool to determine whether a system will be prone to control loop interactions resulting in sensitivity problems that rises from model mismatch in process gains. SVD considers directional changes in the disturbances. SVD is applied to steady state gain matrix that is decomposed into product of three matrices,

$S = U \Sigma V^T$  where  $U$  is matrix of normalized eigen vectors of  $G G_p^T$ ,  $\Sigma$  is diagonal matrix of eigenvalues and  $V$  is matrix of normalized eigenvectors of  $G_p^T G_p$ . The condition number (CN) is defined as ratio between maximum and minimum eigenvalues. Generally if the  $CN < 50$  then the system is not prone to sensitivity problems (a small error in process gain will not cause a large error in the controller's reactions). The greater the CN value, the harder it is for the system in question to be decoupled. An ideal system would have a CN number of one, where each control variable controls a single distinct output variable. CN value tells us how easy it is to decouple a system. Though SVD has good geometric interpretation in terms of selection of measurement and pairing of variables, SVD depends on input-output scaling.

Moreover, with weak interactions and with large dimensional systems they induce to go for more criteria for selection of pairs. Morari resiliency index (MRI) is also used to select in/out pairs.  $MRI = \sigma(G_p(j\omega))$  where  $\sigma$  is eigenvalue. The MRI is the minimum singular value ( $g$ ) of the plant transfer function matrix  $G(i\omega)$ . The set of manipulated variables that gives the largest minimum singular value over the frequency range of interest is the best. The MRI is a measure of the inherent ability of the process (control structure) to handle disturbances, model plant mismatches, changes in operating conditions, etc. The larger the value of MRI, the more resilient the control structure. Dynamic Relative Gain Array (DRGA) is defined to extend the RGA notion to non-zero frequencies. The RGA provides only limited knowledge about when to use multivariable controllers and gives no indication of how to choose multivariable controller structures. A somewhat different approach for investigating channel interaction was therefore employed by Conley and Salgado (2000) and Salgado and Conley (2004) when considering observability and controllability gramians in so called Participation Matrices (PM). In a similar approach Wittenmark and Salgado (2002) introduced the Hankel Interaction Index Array (HIIA). These gramian based interaction measures seem to overcome most of the disadvantages of the RGA. One key property of these is that the whole frequency range is taken into account in one single measure. Furthermore, these measures seem to give appropriate suggestions for controller structures selection. The use of the system  $H_2$  norm as a base for an interaction measure has been proposed by Birk and Medvedev (2003) as an alternative to the HIIA. But, dynamic simulation is a powerful tool to be used to test the viability of a control scheme during various process disturbances. Controllers for MIMO systems can be of either multiloop (controllers are designed only for diagonal elements of process TF) or multivariable (controllers are designed for all the elements of the MIMO TF). Multiloop control scheme has an edge over multivariable as the former can work even if a single loop fails. In presence of interactions between input/output, the process need to be decoupled and then multiloop controllers can be designed. When interaction effects produce a significant deterioration in control system performance, decoupling control should be considered. One of the most powerful and simplest ways of reducing or eliminating interaction is by altering manipulated and / or controlled variables. Improvement of closed-loop performance needs proper tuning of controller parameters that requires process model structure and estimation of respective parameters. There are many methods to select input/output pairs or to design control structures, design control strategy (either PID or IMC or predictive or heuristics etc.) and tuning of controller parameters in literature. But because of hazy pictures on above selections, till today, it is difficult to choose correct pairs, carryout interaction analysis and choose tuning rules. Thus the aim of this chapter is to bring out a clear picture of identifying process parameters and designing controller for MIMO systems. The rest of the chapter is carried out as follows: section 2 discusses identification methods of multivariable systems. Interaction analysis is explained in section 3. Control structure selection and determination of input/output pairs are given in section 4. Tuning of controllers is presented in section 5. Stability analysis for multivariable systems is provided in section 6. At the end, conclusion is drawn.

## 2. System identification

Most of the chemical and bio-chemical processes are multivariable in nature, having more than one input and outputs. Estimation of process parameters is a key element in

multivariable controller design. Thus, as better performance is achieved by model based tuning algorithms, estimation of model structures are necessary from either open-loop or closed-loop data. This is due to the fact that tuning rules are based on model structures & parameters. As their exist advantages and disadvantages in both of these identification strategies, for example, open-loop responses may show unstable behavior with certain inputs, whereas, closed-loop strategy needs more excitation to yield observable response. Here we use mostly used methods of identification for multivariable systems. Least square method (Tungnait 1998) is an old but reliable technique that was in use to estimate multivariable parameters of open-loop systems. But, MIMO systems with interactions may not yield satisfactory transfer function estimates with these techniques. Overschee and Moor (1994) proposed subspace method of identification that mostly applies to identification of multivariable state space models. This method involves more computational time. Practical industrial plants are easy to identify in closed-loop using relay feedback method (Astrom and Hagguland 1984) and Yu (1999) explains advances in autotuning using sequential identification. System identification is the method of estimating parameters from system's input/output data using numerical techniques:

## 2.1 Transfer function identification

Model structures and parameters of transfer function are constructed from observed plant input output data. Transfer function models are developed using three schemes: (a) Least square (b) subspace and (c) sequential identification method. These approximations made out through each of the methods carry errors that propagate to controller tuning and in turn deteriorates the overall performance.

### 2.1.1 Least-squares method

Least-squares method, used to reduce the mean square error, is very simple and more numerically stable and can be used to identify the unknown parameters of the 2x2 MIMO transfer function model from the input (u) and output (y) data. Though any type of forcing function (step, pulses or a sequence of positive and negative pulses) can be used, a very popular sequence of inputs, "Pseudo-random binary sequence" (PRBS) is made use of in the present work.

Let us consider a process with continuous transfer function

$$\frac{y(s)}{u(s)} = G(s) = \frac{K_p e^{-Ds}}{\tau s + 1} \quad (2.1)$$

The pulse transfer function of this process with a zero-order hold is

$$\frac{y(z)}{u(z)} = HG(z) = \frac{K_p(1-b)}{z^{n_k}(z-b)} = \frac{K_p(1-b)z^{-1}}{z^{n_k}(1-bz^{-1})} = \frac{z^{-n_k}(b_0 + b_1 z^{-1})}{1 + a_1 z^{-1}} \quad (2.2)$$

where  $n_k = D/T_s$ ;  $T_s$ =sampling period;

$$b = e^{-T_s/\tau}; b_0 = 0; b_1 = K_p(1-b); a_1 = -b$$

The discrete transfer function has three parameters that need to be identified: dead time ( $D$ ) contained in  $n_k$ , and other two parameters of the model ( $k_p$  and  $\tau$ ) contained in  $b_1$ , and  $a_1$ . The discrete output can be represented in the following form:

$$\bar{y}_n = b_1 u_{n-1} + b_2 u_{n-2} + \dots + b_{nb} u_{n-nb} - a_1 y_{n-1} - a_2 y_{n-2} - \dots - a_{na} y_{n-na} \tag{2.3}$$

where  $\bar{y}_n$  is the predicted value of the current output of the process. For a FOPDT process, equation (2.3) can be written as

$$y(k) + a_1 y(k-1) = b_1 u(k-1) \tag{2.4}$$

which can be written in matrix form as

$$y = \phi \theta + e \tag{2.5}$$

where

$$\phi = \begin{bmatrix} -y(0) & u(0) \\ -y(1) & u(1) \\ \dots & \dots \\ -y(N-1) & u(N-1) \end{bmatrix} \quad \text{and} \quad \theta = \begin{bmatrix} a_1 \\ b_1 \end{bmatrix}$$

The parameters  $a_1$  and  $b_1$  are calculated using

$$\theta = (\phi^T \phi)^{-1} \phi^T y \tag{2.6}$$

where  $\theta$  is the parameter vector  $\phi$  is state matrix and  $y$  is outputs.

**2.2 State-space model**

In the state space form the relationship between the input, noise and output signals are written as a system of first-order differential or difference equations using auxillary state vectors. Transfer function in laplace domain is converted to state space form using a sampling period of 0.1s

**2.2.1 Subspace method**

The beginning of the 1990s witnesses the birth of a new type of linear system identification algorithms, called subspace method. Subspace identification methods are indeed attractive since a state-space realization can be directly estimated from input/output data without nonlinear optimization. Furthermore, these techniques are characterized by the use of robust numerical tools such as RQ factorization and the singular values decomposition (SVD). Interesting from numerical point of view, the batch subspace model identification (SMI) algorithms are not usable for online implementation because of the SVD computational complexity. Indeed, in many online identification scenarios, it is important to update the model as time goes on with a reduced computational cost.

Linear subspace identification methods are concerned with systems and models of the form

$$x_{k+1} = Ax_k + Bu_k + w_k \tag{2.7}$$

$$y_k = Cx_k + Du_k + v_k \tag{2.8}$$

with

$$E \begin{bmatrix} \begin{pmatrix} w_p \\ v_p \end{pmatrix} \begin{pmatrix} w_q^T & v_q^T \end{pmatrix} \end{bmatrix} = \begin{pmatrix} Q & S \\ S^T & R \end{pmatrix} \delta_{pq} \tag{2.9}$$

The vectors  $u_k \in R^{m \times 1}$  and  $y_k \in R^{l \times 1}$  are the measurements at time instant k of, respectively, the m inputs and l outputs of the process. The vector  $x_k$  is the state vector of the process at discrete time instant k,  $v_k \in R^{l \times 1}$  and  $w_k \in R^{n \times 1}$  are unobserved vector signals,  $v_k$  is called the measurement noise and  $w_k$  is called the process noise. It is assumed that they are zero mean, stationary white noise vector sequences and uncorrelated with the inputs  $u_k$ .  $A \in R^{n \times n}$  is the system matrix,  $B \in R^{n \times m}$  is the input matrix,  $C \in R^{l \times n}$  is the output matrix while  $D \in R^{l \times m}$  is the direct feed-through matrix. The matrices  $Q \in R^{n \times n}$ ,  $S \in R^{n \times l}$  and  $R \in R^{l \times l}$  are the covariance matrices of the noise sequences  $w_k$  and  $v_k$ .

In subspace identification it is typically assumed that the number of available data points goes to infinity, and that the data is ergodic. The main problem of identification is arranged as follows:

Given a large number of measurements of the input  $u_k$  and the output  $y_k$  generated by the unknown system described by equations (2.7)-(2.9). The task is to determine the order n of the unknown system, the system matrices A, B, C, D up to within a similarity transformation and an estimate of the matrices Q, S and R.

Subspace identification algorithms always consist of two steps:

Step 1: Make a weighted projection of certain subspace generated from the data, to find an estimate of the extended observability matrix,  $\Gamma_i$  and/or an estimate  $\tilde{X}_i$  of the state sequence  $X_i$  of the unknown system

Step 2: Retrieve the system matrices (A, B, C, D and Q, S, R) and from either this extended observability matrix ( $\Gamma_i$ ) or the estimated states.

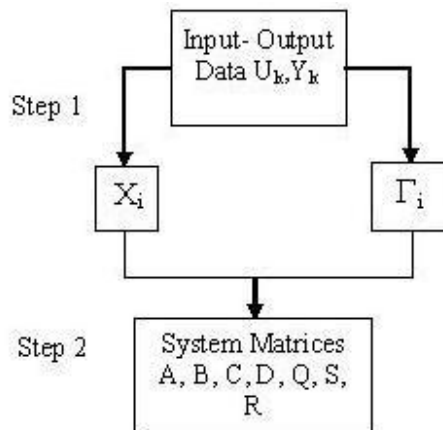
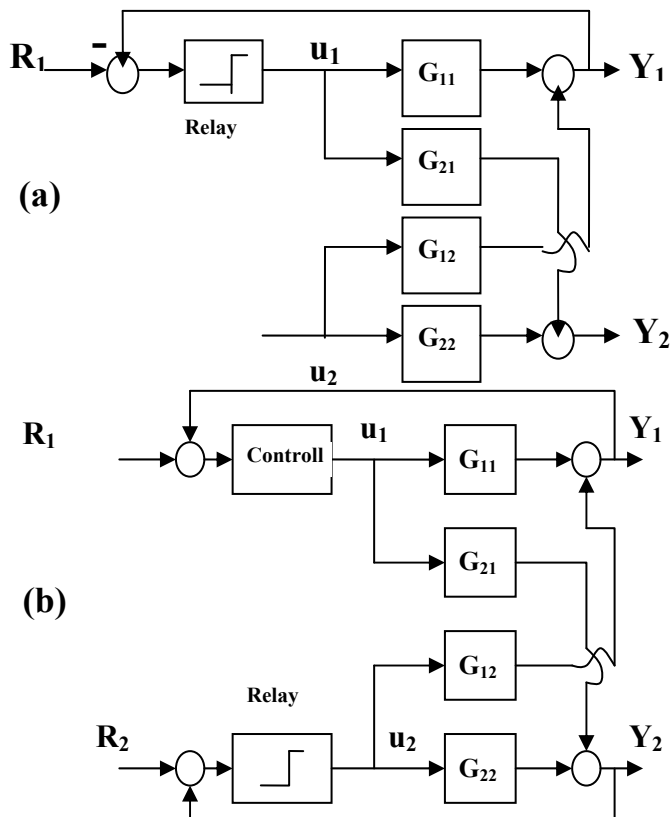

Fig. 1. Flow chart of subspace algorithm.

All the above identification methods involve more computations and many offline methods. These difficulties can be avoided easily by using another method of estimation technique, namely, relay feedback method as explained below:

**2.3 Sequential identification**

Based on the concept of sequential auto tuning (Shen & Yu, 1994) method each controller is designed in sequence. Let’s consider a 2-by-2 MIMO system with a known pairing  $(y_1 - u_1)$  and  $(y_2 - u_2)$  under decentralized PI control (Figure 1). Initially, an ideal / biased relay is placed between  $y_1$  and  $u_1$ , while loop 2 is on manual (Figure 2a). Following the relay-feedback test, a controller can be designed from the ultimate gain and ultimate frequency. The next step is to perform relay-feedback test between  $y_2$  and  $u_2$  while loop 1 is on automatic (Figure 2b). A controller can also be designed for loop 2 following the relay-feedback test. Once the controller on the loop 2 is put on automatic, another relay-feedback experiment is performed between  $y_1$  and  $u_1$ , (Figure 2c). Generally, a new set of tuning constants is found for the controller in loop 1. This procedure is repeated until the controller parameters converge. Typically, the controller parameters converge in 3 - 4 relay-feedback tests for 2 x 2 systems.



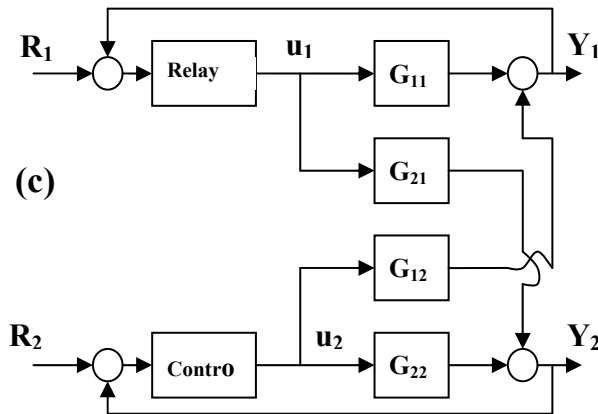

Fig. 2. Sequential method of tuning for 2x2 multivariable system. Steps are: (a) followed by (b) and followed by (c).

In order to proceed with sequential identification, it is necessary to derive closed-loop transfer functions for the above mentioned schemes. The following notations will be used for 2-by-2 MIMO system:

$$g_p(s) = \begin{pmatrix} g_{p11} & g_{p12} \\ g_{p21} & g_{p22} \end{pmatrix} \quad G_c(s) = \begin{pmatrix} G_{c1} & 0 \\ 0 & G_{c2} \end{pmatrix} \quad y(s) = \begin{pmatrix} y_1 \\ y_2 \end{pmatrix} \quad \text{and} \quad u(s) = \begin{pmatrix} u_1 \\ u_2 \end{pmatrix} \quad (2.10)$$

Thus, when perturbation is introduced in the second input  $u_2$ , transfer functions for the input  $u_2(s)$  are

$$y_1 = G_{p12,CL}(s)u_2(s) = -\frac{g_{p12}(s)}{1 + g_{p11}(s)G_{c1}(s)}u_2(s) \quad (2.11)$$

$$y_2(s) = G_{p22,CL}(s)u_2(s) = \left[ g_{p22}(s) - \frac{g_{p21}(s)G_{c1}(s)g_{p12}(s)}{1 + g_{p11}(s)G_{c1}(s)} \right] u_2(s) \quad (2.12)$$

By applying the above identification method to the 2<sup>nd</sup> loop (by collecting output  $y_2$  for the change in input  $u_1$ ), we can obtain models for  $G_{p12,CL}(s)$  and  $G_{p22,CL}(s)$ . Then, we have

$$y_2 = G_{p21,CL}(s)u_1(s) = -\frac{g_{p21}(s)}{1 + g_{p22}(s)G_{c2}(s)}u_1(s) \quad (2.13)$$

$$y_1(s) = G_{p11,CL}(s)u_1(s) = \left[ g_{p11}(s) - \frac{g_{p21}(s)G_{c2}(s)g_{p12}(s)}{1 + g_{p22}(s)G_{c2}(s)} \right] u_1(s) \quad (2.14)$$



From the identified step response models of  $G_{p12,CL}(s)$  and  $G_{p22,CL}(s)$ , we can obtain their frequency response data and, by fitting them, we can get approximate low order models. Time domain modeling is obtained using equations (2.15) and (2.16) for 2x2 and 3x3 MIMO process with FOPDT models using relay feedback test as:

$$y_n = k_{21} \left( 1 - e^{-\frac{t}{\tau_{21}}} \left( \frac{2}{1 + e^{-\frac{p_u}{2\tau_{21}}}} \right) \right) - \frac{k_{22}k_{c2}}{\tau_{i2}} \left( 1 + (\tau_{i2} - \tau_{22}) e^{-\frac{t}{\tau_{22}}} \left( \frac{2}{1 + e^{-\frac{p_u}{2\tau_{22}}}} \right) \right) y_n(t-1) \quad (2.15)$$

$$y_n = k_{21} \left( 1 - e^{-\frac{t}{\tau_{21}}} \left( \frac{2}{1 + e^{-\frac{p_u}{2\tau_{21}}}} \right) \right) - \frac{k_{22}k_{c2}}{\tau_{i2}} \left( 1 + (\tau_{i2} - \tau_{22}) e^{-\frac{t}{\tau_{22}}} \left( \frac{2}{1 + e^{-\frac{p_u}{2\tau_{21}}}} \right) \right) - \left[ \begin{aligned} & \left[ 1 - \left( a_1 e^{-\frac{t}{\tau_{i3}}} \left( \frac{2}{1 + e^{-\frac{p_u}{2\tau_{i3}}} \right)} + a_2 e^{-\frac{t}{\tau_{23}}} \left( \frac{2}{1 + e^{-\frac{p_u}{2\tau_{23}}} \right)} + a_3 e^{-\frac{t}{\tau_{33}}} \left( \frac{2}{1 + e^{-\frac{p_u}{2\tau_{33}}} \right)} \right) \right] - \\ & \left[ \frac{k_{33}k_{c3}}{\tau_{i3}} \left[ 1 + (\tau_{i3} - \tau_{33}) e^{-\frac{t}{\tau_{33}}} \left( \frac{2}{1 + e^{-\frac{p_u}{2\tau_{33}}} \right)} \right] \right] \end{aligned} \right] \quad (2.16)$$

**2.4 Process dynamics of example under study**

Wood and Berry (1973) (WB) reported a column for methanol-water separation with transfer function as given below

$$\begin{bmatrix} x_D \\ x_B \end{bmatrix} = \begin{bmatrix} \frac{12.8e^{-s}}{16.7s + 1} & \frac{-18.9e^{-3s}}{21s + 1} \\ \frac{6.6e^{-7s}}{10.9s + 1} & \frac{-19.4e^{-3s}}{14.4s + 1} \end{bmatrix} \begin{bmatrix} L \\ V \end{bmatrix} \quad (2.17)$$

The compositions of top ( $x_D$ ) and bottom ( $x_B$ ) products expressed in wt% of methanol are controlled variables. The reflux (L) and the reboiler (V) steam flow rates are the manipulated inputs are expressed in lb/min. time constants are in minutes. Feed flow rate is disturbance. Here the input variables are liquid (L) and vapour (V) flow rates (where as feed (F) flow rate is the load); outputs are distillate ( $x_D$ ) and bottom ( $x_B$ ) compositions. This plant given by Eq.(2.15) is considered as actual or real plant-model in present work.

On applying least square algorithms to individual transfer function elements of an unknown 2x2 MIMO process (WB column) the estimated transfer function is obtained as shown in Table 1. The output (y) and input data (to original WB plant transfer function) are used to form matrix. The parameters  $a_1$  and  $b_1$  were calculated using Eq.(2.6).

On applying subspace algorithms to an unknown 2x2 MIMO process (WB column) the following steps are followed

- Step 1: From the transfer function matrix State space representation matrices are calculated.
- Step 2: A, B, C and D matrices are simulate to get output data for a random input signal.

Step 3: From the output and input data Henkel matrix are formed and LQ decomposition method is used to split the matrix

Step 4: Then Singular value decomposition method is used to estimate A, B, C and D matrices.

Step 5: From estimated matrices the transfer function were found.

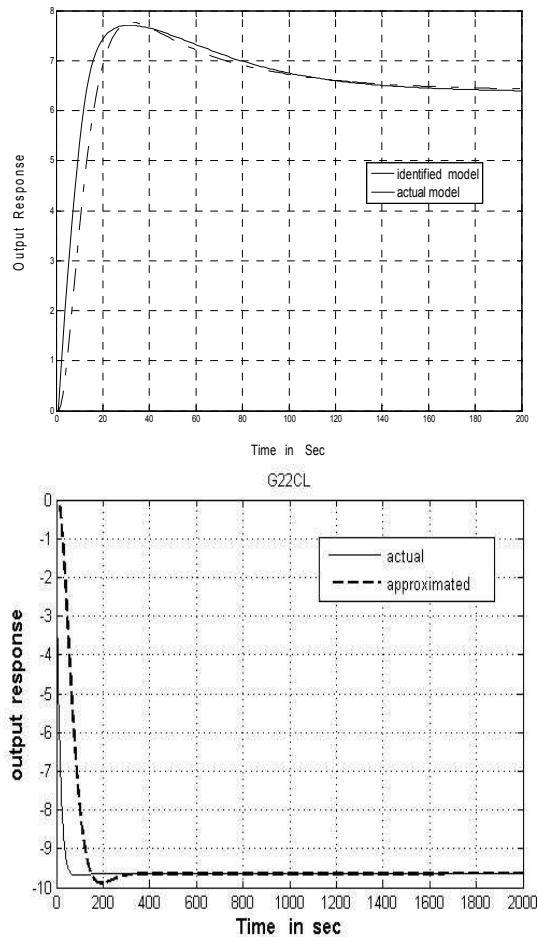

Fig. 3. Comparison of responses between actual (solid) and identified (Sequential identification, dashed line) models of WB column

Mostly, the purpose of identification of transfer functions is to design controller for the system in order to achieve desired performance. Three methods of identifications (two in openloop mode and the other in closed-loop mode) are used to identify the two-input-two-output process, WB column. Least square and subspace methods have been used to identify the process in openloop and sequential identification technique is used to estimate the process in closedloop.

The identified models and actual plant model are compared (Table-2.1). It is found that subspace identification method gives better result/

ACTUAL WB COLUMN	ESTIMATED TRANSFER FUNCTION		
	LEAST SQUARE	SUBSPACE	SEQUENTIAL
$\begin{bmatrix} \frac{12.8e^{-s}}{16.7s+1} & \frac{-18.9e^{-3s}}{21s+1} \\ \frac{6.6e^{-7s}}{10.9s+1} & \frac{-19.4e^{-3s}}{14.4s+1} \end{bmatrix}$	$\begin{bmatrix} \frac{12.692e^{-s}}{16.41s+1} & \frac{-18.89e^{-3s}}{21.46s+1} \\ \frac{6.4e^{-7s}}{10.95s+1} & \frac{-19.6e^{-3s}}{14.481s+1} \end{bmatrix}$	$\begin{bmatrix} \frac{12.799e^{-s}}{16.7541s+1} & \frac{-18.9e^{-3s}}{21.054s+1} \\ \frac{6.600e^{-7s}}{10.9505s+1} & \frac{-19.398e^{-3s}}{14.448s+1} \end{bmatrix}$	$G_{11,CL} = \frac{6.4e^{-s}}{42.25s^2 + 11.7s + 1} \left( \frac{60s + 1}{44s + 1} \right)$ $G_{22,CL} = \frac{-9.655e^{-3s}}{1453s^2 + 58.15s + 1} \left( \frac{0.4774s + 1}{2.741s + 1} \right)$

Table 2.1. Actual and estimated multivariable transfer functions using different methods

After identifying the model structures and estimating process parameters of the models, next work is to select a suitable control strategy for the process.

### 3. Different control strategies

MIMO systems came into use in chemical industries as the processes were redesigned to improve efficiency. Multivariable control involves the objective of maintaining several controlled variables at independent set points. Interaction between inputs and output cause a manipulated variable to affect more than one controlled variable. The various control schemes studied here are the decentralized, centralized and decoupled systems. In decentralized structure, diagonal controllers are used. Hence they result in systems having n controllers. The centralized control systems have n x n controllers. In decoupled systems the process interactions are decoupled before they can actually reach and affect the processes.

#### 3.1 Centralized structure

Centralized control scheme is a full multivariable controller where the controller matrix is not a diagonal one. The decentralized control scheme is preferred over the centralized control scheme mainly because the control system has only n controlling n output variables, and the operator can easily understand the control loops. However, the design methods of such decentralized controllers require first pairing of input-output variables, and tuning of controllers requires trial and error steps. The centralized control system requires n x n controllers for controlling n output variables using n manipulated variables. But if we are calculating the control action using a computer, then this problem of requiring n x n controllers does not exist. The advantage of the centralized controller is easy to tune even with the knowledge of the steady state gain matrix alone, multivariable PI controllers can be easily designed.

For the centralized structure, Internal model control-proportional integral tuning is adopted, based on studies on the studies and recommendations of Reddy et al (1997) on the design of centralized PI controllers for a Multi-stage flash desalination plant using Davison, Maciejowski and Tantt-Lieslehto methods.

The IMC-PID tuning relations are used in tuning the controller. For a first order system of

the form  $\frac{k_p e^{-Ds}}{(\tau s + 1)}$ , the PI controller settings are as follows:

$$k_c = \frac{\tau}{k_p \lambda} \quad (3.1)$$

$$\tau_i = \tau \quad (3.2)$$

where  $\lambda = \max(1/0.7D, 0.2\tau)$

These tuning relations are derived by comparing IMC control with the conventional PID controller and solving to determine the proportional gain and integral time.

### 3.2 Decentralized structure

In spite of developments of advanced controller synthesis for multivariable controllers, decentralized controller remain popular in industries because of the following:

1. Decentralized controllers are easy to implement.
2. They are easy for operators to understand.
3. The operators can easily retune the controllers to take into account the change in process conditions.
4. Some manipulated variables may fail. Tolerances to such failures are more easily incorporated into the design of decentralized controllers than full controllers.
5. The control system can be brought gradually into service during process start up and taken gradually out of service during shut down.

The design of a decentralized control system consists of two main steps:

Step 1 is control structure selection and step 2 is the design of a SISO controller for each loop.

In decentralized control of multivariable systems, the system is decomposed into a number of subsystems and individual controllers are designed for each subsystem.

For tuning the controller, Biggest Log Modulus Tuning (BLT) method (Lubed 1986) is used, which is an extension of the Multivariable Nyquist Criterion and gives a satisfactory response. A detuning factor  $F$  (typical values are said to vary between 2 and 5) is chosen so that closed-loop log modulus,  $L_{cm}^{max} \geq 2n$ ,

$$L_{cm} = 20 \log \left| \frac{w}{1+w} \right| \quad (3.3)$$

$$w = -1 + \det(I + G_p G_c) \quad (3.4)$$

where  $G_c$  is an  $n \times n$  diagonal matrix of PI controller transfer functions,  $G_p$  is an  $n \times n$  matrix containing the process transfer functions relating the  $n$  controlled variables to  $n$  manipulated variables.

Now the PI controller parameters are given as,

$$k_{ci} = k_{ciZ-N} / F \quad (3.5)$$

$$\tau_{li} = F \tau_{liZ-N} \quad (3.6)$$

where  $k_{ciZ-N}$  and  $\tau_{liZ-N}$  are Zeigler-Nichols tuning parameters which are calculated from the system perturbed in closed loop by a relay of amplitude  $h$ , reaches a limit cycle whose

amplitude  $a$  and period of oscillation  $P$ , are correlated with the ultimate gain ( $k_u$ ) and frequency ( $\omega_u$ ) by the following relationships:

$$k_u = \frac{4h}{\pi a} \tag{3.7}$$

$$\omega_u = \frac{2\pi}{P_u} \tag{3.8}$$

Detuning factor  $F$  determines the stability of each loop. The larger the value of  $F$ , more stable the system is but set point and load responses are sluggish. This method yields settings that give a reasonable compromise between stability and performance in multivariable systems.

The decentralized scheme is more advantageous in the fact that the system remains stable even when one controller goes down and is easier to tune because of the less number of tuning parameters. But however pairing (interaction) analysis needs to be done as  $n!$  pairings between input/output are possible.

### 3.3 Decoupled structure

This structure has additional elements called decouplers to compensate for the interaction phenomenon. When Relative gain Array shows strong interaction then a decoupler is designed. But however decouplers are designed only for orders less than 3 as the design procedure becomes more complex as order increases.

The BLT (Luyben 1986) procedure of tuning the decentralized structure follows the generalized way for all  $n \times n$  systems as mentioned above. The centralized controllers are tuned using the IMC-PI tuning relations which are appropriately selected for first order and second order systems.

The decoupled structure adopts the various methods like partial, static and dynamic decoupling to procedure the best results. The design equations for a general decoupler for  $n \times n$  systems are conveniently summarized using matrix notations defined as follows:

$$G = \begin{bmatrix} G_{11}(s) & G_{1n}(s) \\ G_{n1}(s) & G_{nn}(s) \end{bmatrix}; D = \begin{bmatrix} D_{11}(s) & D_{1n}(s) \\ D_{n1}(s) & D_{nn}(s) \end{bmatrix}; H = \begin{bmatrix} H_{11}(s) & \dots & 0 \\ \dots & H_{22}(s) & \dots \\ 0 & \dots & H_{nn}(s) \end{bmatrix}$$

Transfer function matrix; Decoupler matrix; Diagonal matrix of decoupler

$$u = \begin{bmatrix} u_1 \\ \dots \\ u_n \end{bmatrix}; \quad M = \begin{bmatrix} M_1 \\ \dots \\ M_n \end{bmatrix}; \quad C = \begin{bmatrix} C_1 \\ \dots \\ C_n \end{bmatrix}$$

Manipulated variable (new)      Manipulated variable (old)      Output  
 For a decoupled multivariable system, output can be written as

$$C = GM \tag{3.9}$$

$$M = Du \tag{3.10}$$

The equation (3.10) becomes,

$$C = GDu \quad (3.11)$$

The equation (3.11) becomes,

$$C = Hu \quad (3.12)$$

where,

$$GD = H \quad (3.13)$$

or

$$D = G^{-1}H \quad (3.14)$$

which defines the decoupler

For a  $2 \times 2$  system, equations are derived for decouplers, taking that loop and the other interacting loops into account.

### 3.4 Examples

#### 3.4.1 Centralized controller

A first order plus dead time process with  $k_p = 1$ ,  $\tau_p = 1$  and  $D_p = 0.25$  is chosen for simulation study. The controller is designed with a first order filter with  $\lambda = 1.4286$ ,  $k_c = 0.7$  and  $\tau_I = 1$ . Closed loop responses with the present controller are obtained. The results are shown below:

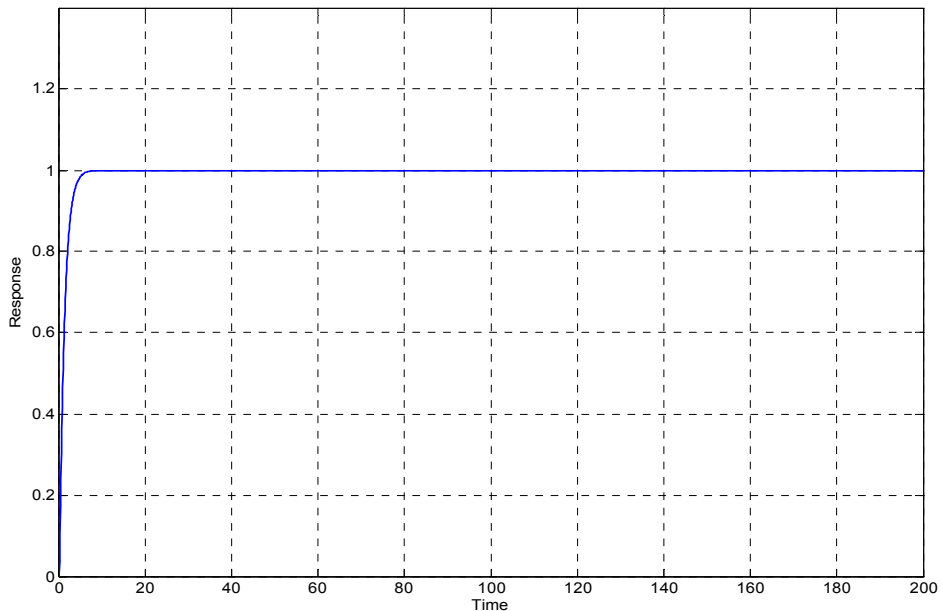

Fig. 4. Closed-loop response of example -processes using PID controller

### 3.4.2 Decentralized controller

The wood and berry distillation column process whose transfer function

$$\begin{bmatrix} \frac{12.8e^{-s}}{16.7s + 1} & \frac{-18.9e^{-3s}}{21s + 1} \\ \frac{6.6e^{-7s}}{10.9s + 1} & \frac{-19.4e^{-3s}}{14.4s + 1} \end{bmatrix}$$

is chosen for simulation study. The controller is designed using BLT method with  $F=2.55$ ,  $k_{c1} = 0.375$ ,  $\tau_{I1} = 8.29$  (loop 1 controller settings) and  $k_{c2} = -0.075$ ,  $\tau_{I2} = 23.6$  (loop 2 controller settings). With these settings, the closed loop responses are obtained and are shown below.

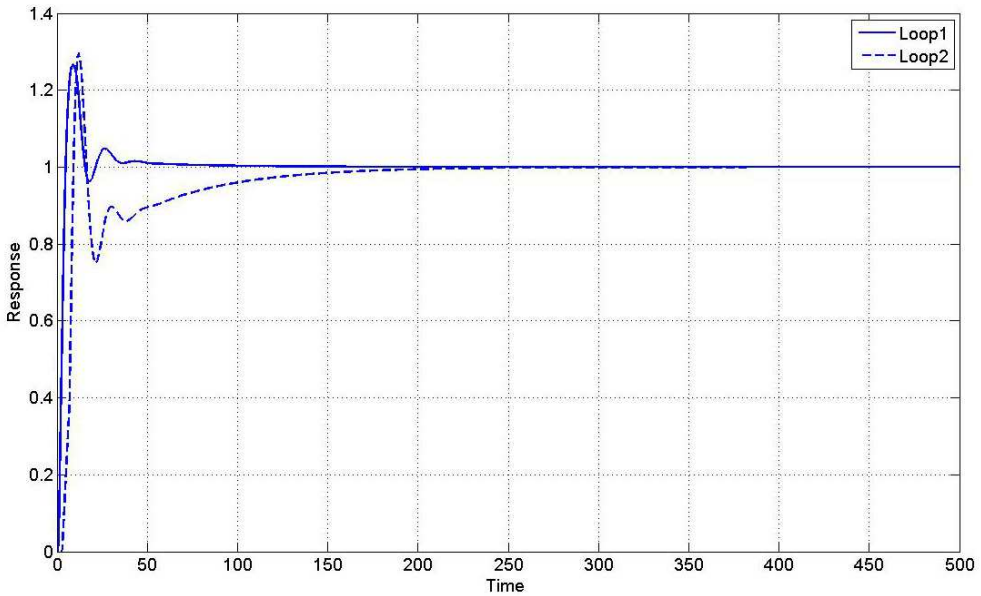

Fig. 5. Closed-loop response with BLT tuning for WB -Column using PID controller (solid line is loop 1 response and dashed line is loop 2 response)

### 3.4.3 Decoupled PID controller

The Wood and Berry binary distillation column is a multivariable system that has been studied extensively. The process has transfer function

$$\begin{bmatrix} \frac{12.8e^{-s}}{16.7s + 1} & \frac{-18.9e^{-3s}}{21s + 1} \\ \frac{6.6e^{-7s}}{10.9s + 1} & \frac{-19.4e^{-3s}}{14.4s + 1} \end{bmatrix} \quad (3.15)$$

The decoupler is given by

$$D = G^{-1}(0) = \frac{1}{\det(G(0))} \begin{pmatrix} g_{22}(0) & -g_{12}(0) \\ -g_{21}(0) & g_{11}(0) \end{pmatrix} \quad (3.16)$$

$$D = G^{-1}(0) = \frac{1}{-123.58} \begin{pmatrix} -19.4 & -18.9 \\ 6.6 & 12.8 \end{pmatrix}$$

$$D = \begin{pmatrix} 0.15698 & 0.15293 \\ 0.0534 & -0.1035 \end{pmatrix}$$

The transfer function of the statistically decoupled system is given by

$$Q = GD \text{ or } Q = GG^{-1}(0) \quad (3.17)$$

$$Q = \begin{bmatrix} \frac{12.8e^{-s}}{16.7s+1} & \frac{-18.9e^{-3s}}{21s+1} \\ \frac{6.6e^{-7s}}{10.9s+1} & \frac{-19.4e^{-3s}}{14.4s+1} \end{bmatrix} \begin{pmatrix} 0.15698 & 0.15293 \\ 0.0534 & -0.1035 \end{pmatrix}$$

## 4. Input-output pairing

Many control systems are multivariable in nature. In such systems, each manipulated variable (input signal) may affect several controlled variables (output signals) causing interaction between the input/output loops. Due to these interactions, the system becomes more complex as well as the control of multivariable systems is typically much more difficult compared to the single-input single-output case.

### 4.1 The Relative Gain Array analysis

The RGA is a matrix of numbers. The  $i$ th element in the array is called  $\beta_{ij}$ . It is the ratio of the steady-state gain between the  $i$ th controlled variable and the  $j$ th manipulated variable when all other manipulated variables are constant, divided by the steady-state gain between the same two variables when all other controlled variables are constant.

$$\beta_{ij} = \frac{\left[ \frac{y_i}{m_j} \right]_{m_k}}{\left[ \frac{y_i}{m_j} \right]_{y_k}} \quad (4.1)$$

For example, suppose we have a 2 X 2 system with the steady-state gains  $k_{p_{ij}}$

$$y_1 = k_{p_{11}}m_1 + k_{p_{12}}m_2 \quad (4.2)$$

$$y_2 = k_{p_{21}}m_1 + k_{p_{22}}m_2$$

For this system, the gain between  $y_1$  and  $m_1$  when  $m_2$  constant is



$$\left[ \frac{y_1}{m_1} \right]_{m_2} = k_{p11}$$

The gain between  $y_1$  and  $m_1$  when  $y_2$  is constant ( $y_2 = 0$ ) is found from solving the equations

$$y_1 = k_{p11}m_1 + k_{p12}m_2$$

$$0 = k_{p21}m_1 + k_{p22}m_2$$

$$y_1 = k_{p11}m_1 + k_{p12} \left[ \frac{k_{p21}m_1}{k_{p22}} \right]$$

$$y_1 = \left[ \frac{k_{p11}k_{p22} - k_{p12}k_{p21}}{k_{p22}} \right] m_1 \tag{4.3}$$

$$\left[ \frac{y_1}{m_1} \right]_{y_2} = \left[ \frac{k_{p11}k_{p22} - k_{p12}k_{p21}}{k_{p22}} \right] \tag{4.4}$$

Therefore the term  $\beta_{11}$  in RGA is

$$\beta_{11} = \frac{1}{1 - \frac{k_{p12}k_{p21}}{k_{p11}k_{p22}}} \tag{4.5}$$

**Example:** Calculate  $\beta_{11}$  element of RGA for the wood and berry column

$$k_p = \begin{bmatrix} 12.8 & -18.9 \\ 6.6 & -19.4 \end{bmatrix}$$

$$\beta_{11} = \frac{1}{1 - \frac{k_{p12}k_{p21}}{k_{p11}k_{p22}}} = \frac{1}{1 - \frac{(-18.9)(6.6)}{(12.8)(-19.4)}} = 2.01$$

### 4.2 Singular Value Decomposition

SVD is a numerical algorithm developed to minimize computational errors involving large matrix operations. The singular value decomposition of matrix K results in three component matrices as follows:

$$k = U \Sigma V^T \tag{4.6}$$

where K is an  $n \times m$  matrix. U is an  $n \times n$  orthonormal matrix, the columns of which are called the ‘left singular vectors’. V is an  $m \times m$  orthonormal matrix, the columns of which are called the ‘right singular vectors’.  $\Sigma$  is an  $n \times m$  diagonal matrix of scalars called the “singular values”

SVD is designed to determine the rank and the condition of a matrix and to show geometrically the strengths and weaknesses of a set of equations so that the errors during computation can be avoided.

#### 4.2.1 Example

Consider a very simple mixing example, a multivariable process whose gain matrix is as follows:

$$k = \begin{bmatrix} 0.7778 & -0.3889 \\ 1.0000 & 1.0000 \end{bmatrix}$$

which decomposes to

$$U = \begin{bmatrix} 0.2758 & -0.9612 \\ 0.9612 & 0.2758 \end{bmatrix}$$

$$V = \begin{bmatrix} 0.8091 & -0.5877 & 0.8091 \\ 0.5877 & 1.0000 & 0.8091 \end{bmatrix}$$

$$\Sigma = \begin{bmatrix} 1.4531 & 0 \\ 0 & 0.8029 \end{bmatrix}$$

At this point these singular values and vectors are merely numbers; however, consider the relationship between these values and an experimental procedure that could be applied to measure the steady-state process characteristics.

#### 4.3 Niederlinski index

A fairly useful stability analysis method is the Niederlinski index. It can eliminate unworkable pairings of variables at an early stage in the design. The controller settings need not be known, but it applies only when integral action is used in all the loops. It utilizes only the steady state gains of the process transfer function matrix. The method is necessary but not the sufficient condition for stability of a closed loop system with integral action. If the index is negative, the system will be unstable for any controller settings. If the index is positive, the system may or may not be stable. Further analysis is necessary.

$$\text{Niederlinski index} = \text{NI} = \frac{\text{Det}[k_p]}{\prod_{j=1}^N k_{pjj}} \quad (4.7)$$

where,  $k_p$  is a matrix of steady state gains from the process openloop transfer function

$k_{pjj}$  is the diagonal elements in steady state gain matrix

Example: Calculate the Niederlinski index for the wood and berry column:

$$k_p = \begin{bmatrix} 12.8 & -18.9 \\ 6.6 & -19.4 \end{bmatrix}$$

$$NI = \frac{Det[k_p]}{\prod_{j=1}^N k_{pjj}} = \frac{(12.8)(-19.4) - (-18.9)(6.6)}{(12.8)(-19.4)} = 0.498 \tag{4.8}$$

Since NI is positive, the closed loop system with the specified pairing may be stable.

**4.4 Gramian based interaction measures**

In 2004, Salgado and Conley investigated the channel interaction by considering controllability and observability gramians so called participation matrix. Similarly, Wittenmark and Salgado (2002) introduced Hankel Interaction Index array. These gramian measures namely HIIA, PM overcome the disadvantages of RGA. One key property of these is that the whole frequency range is taken into account in one single measure. Interaction measures recommend the input-output pairings that result in the largest sum when adding the corresponding elements in the measure. HIIA and PM give appropriate suggestions for decentralized multivariable controller.

The controllability Gramian, P, defined for stable time-invariant systems as

$$P = \int_0^{\infty} e^{A\tau} B B^T e^{A^T \tau} d\tau \tag{4.9}$$

If P has full rank, the system is state controllable.

A stable system will be *state observable* if the observability Gramian, Q, defined as

$$Q = \int_0^{\infty} e^{A\tau} C C^T e^{A^T \tau} d\tau \tag{4.10}$$

If Q has full rank, the system is state observable

These Gramians can be obtained by solving the following continuous time Lyapunov equations:

$$\left. \begin{aligned} AP + PA^T + BB^T &= 0 \\ A^T Q + QA + C^T C &= 0 \end{aligned} \right\} \tag{4.11}$$

Hankel singular values with controllability and observability gramians P and Q is given by

$$\sigma_H^{(i)} \triangleq \sqrt{\lambda_i} \quad i = 1, 2, \dots, n \tag{4.12}$$

The Hankel norm of the system with the transfer function G is

$$\|G\|_H \triangleq \sigma_H^{(1)} = \sqrt{\lambda_{\max}(PQ)} \tag{4.13}$$

**Hankel interaction index array**

The normalized version is the HIIA given by

$$[\mathcal{S}_H]_{ij} = \frac{\|G_{ij}\|_H}{\sum_{kl} \|G_{kl}\|_H} \tag{4.14}$$

**Participation matrix**

Hankel norm is the largest singular values. For elementary SISO subsystems with several HSVs it can be argued that a more relevant way of quantifying the interaction is to take into account all of the HSVs, atleast if there are several HSVs that are of magnitudes close to maximum HSV.

Each element in PM is defined by

$$[\phi]_{ij} = \frac{tr(P_j Q_i)}{tr(PQ)} \tag{4.15}$$

$tr(P_j Q_i)$  is the sum of squared HSVs of the subsystems with input and output.

$tr(PQ)$  equals the sum of all  $tr(P_j Q_i)$

Gramian based interaction measures are calculated and these values for benchmark 2-by-2 MIMO process is given in table 4.1.

2X2 MIMO PROCESS	HIIA		PM	
WB	0.2218	0.3276	0.1741	0.3796
	0.1144	0.3362	0.463	0.4000

Table 4.1. HIIA and PM for benchmark 2-by-2 MIMO process

**5. Tuning of controller**

Consider a process with transfer function  $G_p(s) = \frac{k_p e^{-D_p s}}{\tau_p s + 1}$ . This transfer function has two

parts. One invertible:  $G_p^-$  and the other containing non-invertible part  $G_p^+$  (time delay or right half plane zero that gives non-minimum phase behaviour). The IMC controller can be

expressed as:  $G_c^{IMC} = \frac{1}{G_p^-}$  where  $G_p^- = \frac{k_p}{\tau_p s + 1}$  and  $G_p^+ = e^{-D_p s}$ .

Let us consider the desired closed loop response as  $\frac{y}{R} = \frac{G_p^+}{(\lambda s + 1)} = \frac{e^{-D_p s}}{(\lambda s + 1)}$  which can be

equated to complimentary sensitive function as  $\frac{y}{R} = \frac{G_c^{true} G_p}{1 + G_c^{true} G_p}$ . Thus the true controller

can be expressed as:

$$G_c^{true} = \frac{G_c^{IMC}}{1 - \left(\frac{y}{R}\right)_d G_c^{IMC}} = \frac{1/G_p^-}{(\lambda s + 1) - G_p^+} \tag{5.1}$$

The right hand side of this equation can be written or rearranged to

$$G_c^{true} = \frac{1/G_p^-}{(\lambda s + 1) - e^{-D_p s}} \tag{5.2}$$

In fact, the standard form of a PID controller can be given as

$$G_c^{true} = \frac{f(s)}{s} \text{ Or } G_c^{true} = \frac{(\beta s + 1)f(s)}{s(\beta s + 1)} = \frac{\phi(s)}{s(\beta s + 1)} \text{ where } \beta = \alpha \tau_D \tag{5.3}$$

This true controller can be expanded near the vicinity of s=0 using Laurent series as

$$G_c^{true}(s) = \frac{1}{s(\beta s + 1)} \left[ \sum_{j=-\infty}^{\infty} c_j(s)^j \right] = \frac{1}{s(\beta s + 1)} \left[ \dots + \phi(0) + \phi'(0)s + \phi''(0)\frac{s^2}{2!} + \dots \right] \tag{5.4}$$

By comparing the coefficients of s in equation (5.4) with the standard PID controller, we get

$$\begin{aligned} k_c &= a_0 = \phi'(0) = f'(0) + \beta f(0) \\ \frac{k_c}{\tau_I} &= b_1 = \phi(0) = f(0) \\ k_c \tau_D &= a_1 = \frac{\phi''(0)}{2!} = \frac{f'(0) + 2\beta f'(0)}{2} \end{aligned} \tag{5.5}$$

where

$$\begin{aligned} G_c(s) &= \frac{\phi(s)}{(\beta s + 1)} \\ \phi(s) &= (\beta s + 1)f(s) \end{aligned} \tag{5.6}$$

The method described in earlier section is applied to some standard transfer functions and the comprehensive results are presented in Table 5.1 and selection of λ is given in Table 5.2.

Detailed analysis on synthesis of PID tuning rules can be seen in Panda (2008 & 2009).

Example 5.1: The wood and berry binary distillation column is a multivariable system that has been studied extensively. The process has transfer function

$$\begin{bmatrix} \frac{12.8e^{-s}}{16.7s + 1} & \frac{-18.9e^{-3s}}{21s + 1} \\ \frac{6.6e^{-7s}}{10.9s + 1} & \frac{-19.4e^{-3s}}{14.4s + 1} \end{bmatrix} \tag{5.7}$$

The closed loop response is given in Figure 5.1.

Example 5.2: The transfer function of multiproduct plant distillation column for the separation of binary mixture of ethanol-water (Ogunnaike-Ray (OR) column) is given by

$$\begin{bmatrix} y_1 \\ y_2 \\ y_3 \end{bmatrix} = \begin{bmatrix} \frac{0.66e^{-2.6s}}{6.7s+1} & \frac{-0.61e^{-3.5s}}{8.64s+1} & \frac{-0.0049e^{-s}}{9.06s+1} \\ \frac{-2.36e^{-3s}}{5s+1} & \frac{-2.3e^{-3s}}{5s+1} & \frac{-0.01e^{-1.2s}}{7.09s+1} \\ \frac{-34.68e^{-9.2s}}{8.15s+1} & \frac{46.2e^{-9.4s}}{10.9s+1} & \frac{0.87(11.61s+1)e^{-s}}{(3.89s+1)(18.8s+1)} \end{bmatrix} \begin{bmatrix} u_1 \\ u_2 \\ u_3 \end{bmatrix} \quad (5.8)$$

The closed loop response is given in Figure 5.2.

Transfer Function	PID-Tuning Rules
$\frac{K_p e^{-D_p s}}{\tau_p s + 1}$	$k_c = \frac{\tau_I}{k_p(\lambda + D_p)}; \tau_I = (\tau_p + \beta) + \frac{D_p^2}{2(\lambda + D_p)}; \tau_D = \frac{D_p^2}{2(\lambda + D_p)\tau_I} \left[ (\tau_I - \beta) - \frac{D_p}{3} \right] + \frac{\beta\tau_p}{\tau_I}$
$\frac{K_p e^{-D_p s}}{\tau_p^2 s^2 + 2\zeta\tau_p s + 1}$	$k_c = \frac{\tau_I}{k_p(2\lambda + D_p)}; \tau_I = (2\zeta\tau_p + \beta) - \frac{2\lambda^2 - D_p^2}{2(2\lambda + D_p)};$ $\tau_D = \frac{(\tau_p^2 + 2\zeta\tau_p\beta)}{\tau_I} - \frac{2\lambda^2 - D_p^2}{2(2\lambda + D_p)\tau_I} \left[ (\tau_I - \beta) + \frac{D_p^3}{3(2\lambda^2 - D^2)} \right]$
$\frac{K_p(\tau_{pz}s + 1)e^{-D_p s}}{(\tau_p^2 s^2 + 2\zeta\tau_p s + 1)(\tau_{p1}s + 1)}$	$k_c = \frac{\tau_I}{k_p(3\lambda + D_p - \tau_{pz})}; \tau_I = (\tau_{p1} + 2\zeta\tau_p + 2\beta) - \frac{(3\lambda^2 + D_p\tau_{pz} - \frac{D_p^2}{2})}{(3\lambda + D_p - \tau_{pz})}$ $\tau_D = \frac{\left\{ (\tau_p^2 + 2\zeta\tau_p(\tau_{p1} + \beta) + \beta\tau_{p1}) - \frac{c}{a} \right\} - \frac{b}{a}(\tau_I - \beta)}{\tau_I}$ $a = k_p(3\lambda + D_p - \tau_{pz}); b = 3\lambda^2 + D_p\tau_{pz} - \frac{D_p^2}{2}; c = \lambda^3 - \frac{D_p^2\tau_{pz}}{2} + \frac{D_p^3}{6}$

Table 5.1. Analytical expressions for PID controller parameters for standard transfer functions

	FOPDT	SOPDT	IPDT
PI	$\lambda = \max(1.7D_p, 0.2\tau_p)$	$\lambda = \max(0.25D_p, 0.2\tau_p)$	$\lambda = D_p\sqrt{10}$
PID	$\lambda = \max(0.25D_p, 0.2\tau_p)$	$\lambda = \max(0.25D_p, 0.2\tau_p)$	$\lambda = D_p\sqrt{10}$

Table 5.2.  $\lambda$  selection rule

## 6. Stability analysis

### 6.1 INA and DNA methods

Rosenbrock extended the nyquist stability and design concepts to MIMO systems containing significant interaction. The methods are known as the inverse and direct Nyquist array (INA and DNA) methods. As an extension from the SISO nyquist stability and design concepts, these methods use frequency response approach. These techniques are used because of their simplicity, high stability, and low noise sensitivity. In actual applications, there will be a

region of uncertainty for interaction, as the process transfer function can be different from what was used in the controller design (due to modeling errors and process variations).

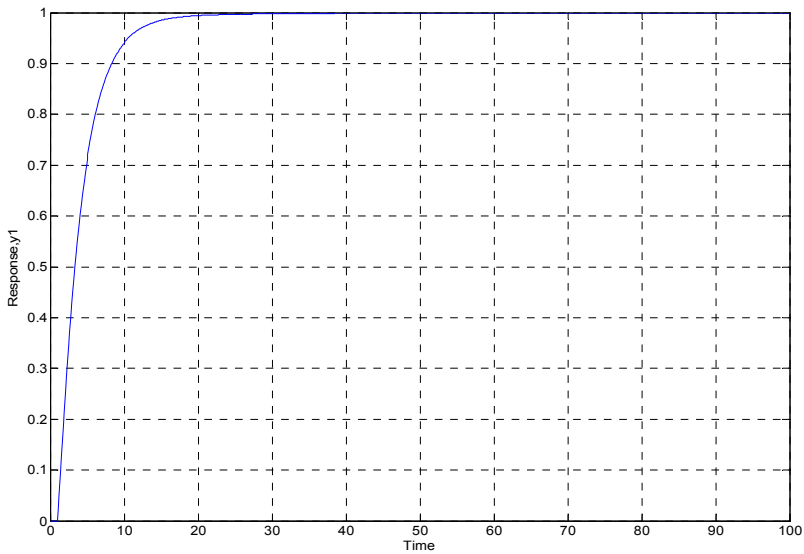

(a)

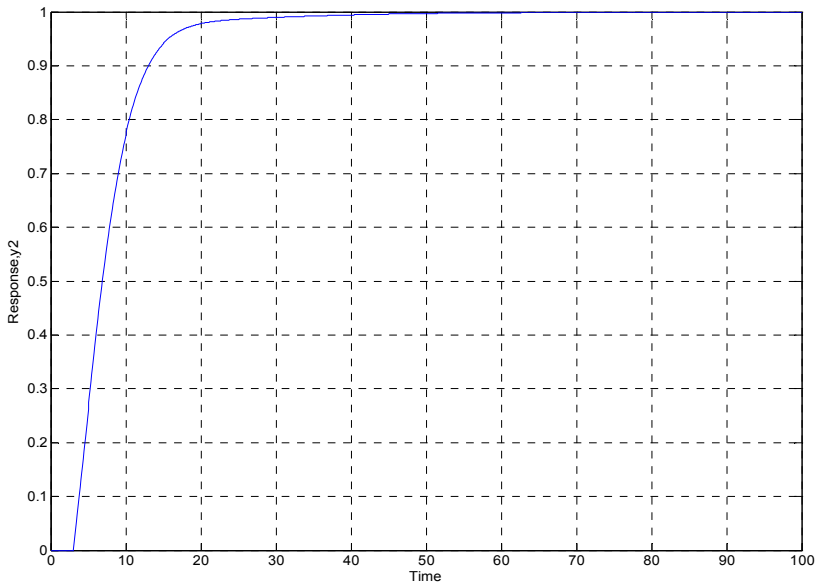

(b)

Fig. 5.1. Closed-loop responses (a: Loop-1 and b: Loop-2) to setpoint changes of example (5.1) -processes using PID controller

### 6.2 Nyquist Stability Theorem

Suppose that  $G(s)$  is an  $n \times n$  system with a decentralized control system  $C(s) = \text{diag}\{c_1(s), \dots, c_n(s)\}$  and that the matrix,  $1 + G(s)C(s)$ , is column diagonally dominant on the nyquist contour, i.e.

$$|1 + g_{ll}(s)c_l(s)| > R_l(s)|c_l(s)| \quad (6.1)$$

where

$$R_l(s) = \sum_{k=1, k \neq l}^n |g_{kl}(s)| \quad (6.2)$$

for  $l = 1, 2, \dots, n$  and for all  $s$  on the Nyquist contour

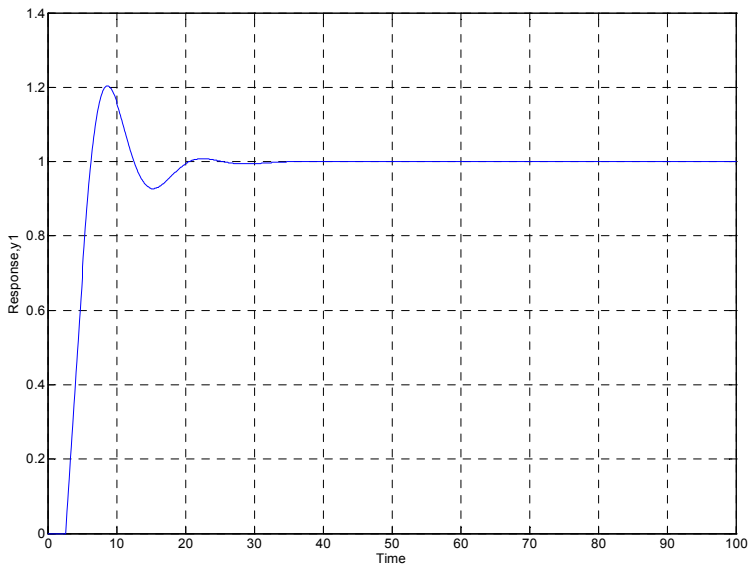

(a)



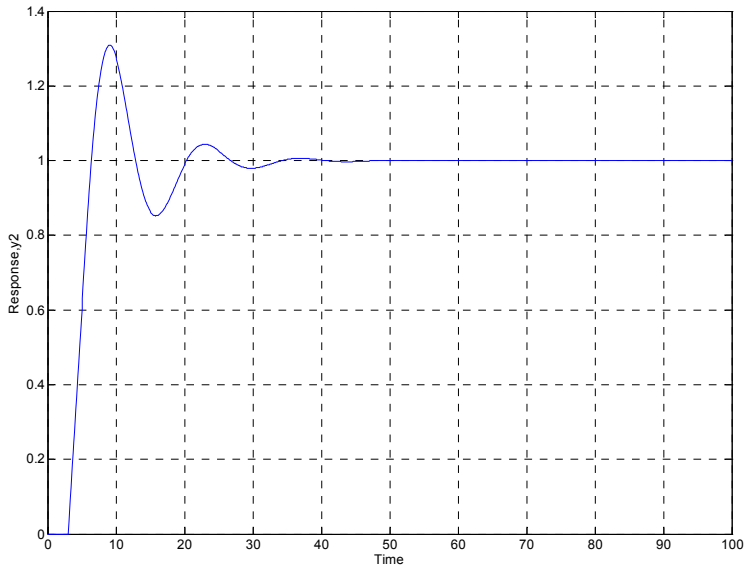

(b)

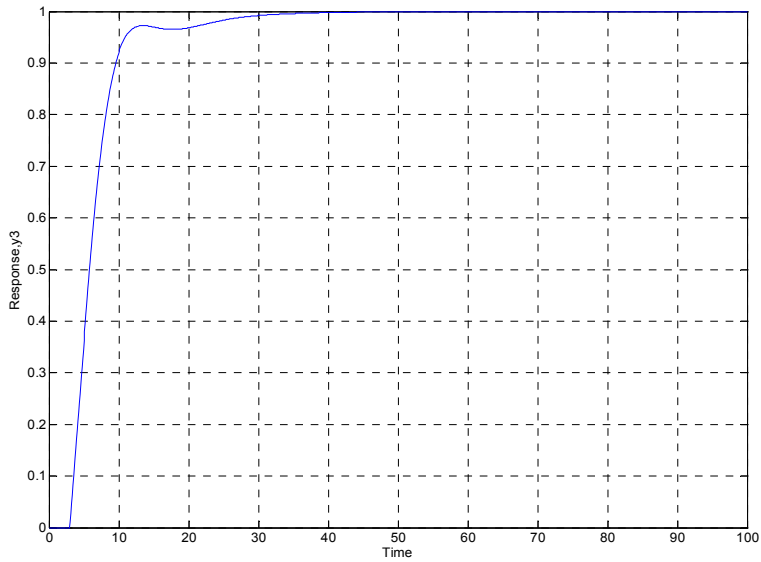

(c)

Fig. 5.2. Closed-loop responses (a: loop-1; b: loop-2 and c: loop-3) to setpoint changes of example 5.2-processes using PID controller

### 6.3 INA design methodology

The following is the design procedure for the INA technique:

1. Obtain  $G(s)$  and calculate its inverse,  $\hat{G}(s)$ .
2. Select an appropriate frequency range; usually  $0 \leq \omega \leq \omega_c$ , where  $\omega_c$  is the frequency above which the response is certain to become and remain negligible.
3. Obtain the inverse nyquist array, which is the  $m^2$  nyquist diagrams of the elements of  $\hat{G}(s)$ .
4. Design compensators, which transform the non dominant  $\hat{G}(s)$  to a diagonally dominant.
5. To verify dominance, calculate the appropriate gershgorin circles for the diagonal elements of the INA at various frequencies. The size of the gershgorin circles measures the importance of off-diagonal (interacting) elements relative to diagonal elements.
6. The INA and gershgorin bands provide the amount of gain that may be applied to each of the loops without violating the stability requirement.

### 6.4 Example

Johansson and Koivo designed a multivariable controller for a boiler subsystem where the boiler was a 1.6MW water boiler using solid fuel. Significant interaction was present between the loops in the subsystem, which consisted of the boiler underpressure and flue gas oxygen content as outputs with damper position and motor speed of the secondary blower as associated inputs. The output vector is  $y = [y_1 \ y_2]^T$  where  $y_1$  is the normalized boiler underpressure and  $y_2$  is the percentage flue gas oxygen content. The input vector is  $u = [u_1 \ u_2]^T$  where  $u_1$  is the damper position (%) and  $u_2$  is secondary blower speed (rpm). The dynamics of the subsystem were determined from step response experiments. First order plus dead time responses were obtained, which produced the transfer function matrix:

$$G(s) = \begin{bmatrix} \frac{e^{-2s}}{(10s+1)} & \frac{-1}{(10s+1)} \\ 0 & \frac{e^{-10s}}{(60s+1)} \end{bmatrix} \quad (6.3)$$

The response of the flue gas oxygen content to step change in damper position was very slow and small in amplitude; therefore  $g_{21}(s)$  was taken as zero. However, the secondary blower speed,  $u_2$ , affects both outputs.

The inverse of  $G$  can be written immediately as:

$$G^{-1}(s) = \begin{bmatrix} -e^{2s}(10s+1) & e^{12s}(60s+1) \\ 0 & e^{10s}(60s+1) \end{bmatrix} \quad (6.4)$$

Consider the  $g_{11}$  element, first replace  $s$  with  $j\omega$  which produces:

$$-e^{2s}(10s+1) = -e^{2j\omega}(10j\omega+1) \quad (6.5)$$

Using Euler's relation,

$$-e^{2j\omega}(10j\omega+1) = (10\omega \sin 2\omega - \cos 2\omega) + j(-10\omega \cos 2\omega - \sin 2\omega) \quad (6.6)$$

Consider  $\omega=0$ ,  $g_{11}(0)=-1$

To compute the radius,  $g_{12}(\omega)$  is calculated as:

$$g_{12}(\omega) = -[(\cos 12\omega - 60\omega \sin 12\omega) - j(60\omega \cos \omega + \sin 12\omega)]$$

Recall that the magnitude of a complex number is the square root of the sum of real part squared and the imaginary part squared. Therefore,  $g_{12}(0)=1$

A constant pre-compensator was designed to obtain dominance. This was

$$k = \begin{bmatrix} 1 & -1 \\ 0 & 1 \end{bmatrix} \quad (6.7)$$

## 7. Conclusion

Thus in this chapter, it was found that least square and subspace methods have been used to identify process in open loop and sequential identification technique is used to estimate the process in closed loop. And the decentralized controllers are tuned using BLT method results in a stable controller. Finally, all the interaction tools are discussed as well the stability of the MIMO processes. The IMC-PID tuning rule suggested in this article yields fast and robust responses.

The following step-by-step procedure may be employed to solve a multi-variable control problem:

1. Choose an appropriate pairings of controlled and manipulated variables, by interaction analysis.
2. If interaction is modest, one may consider SISO controllers for the multi-variable system.
3. If interaction is significant, it may be possible to use decouplers to reduce interaction in conjunction with PID-type controllers.
4. An alternative to steps 2 and 3 is to use a full multi-variable control technique that inherently compensates for interactions.

Based on the concept of sequential identification-design, an approach for the automatic tuning of multivariable systems is discussed. Several system identification methods like subspace identification, least squares, relay feedback methods are used to determine dynamic parameters of a specific model structure from plant data (real time).

## 8. Acknowledgement

Authors wish to acknowledge the financial support of DST / SR-S3-CE-90-2009 in carrying out this research work

## 9. References

- [1] Multivariable Process control, Pradeep B. Deshpande, ISA, Research Triangle Park, NC, U.S.A, 1989
- [2] Autotuning of PID controllers, C.C.Yu, Springer Verlag, London, 2<sup>nd</sup> Edition, 2006
- [3] Control configuration selection for multivariable plants, Ali Khaki-Sedigh and Bijan Moaveni, Springer, Berlin, Heidelberg, 2009.
- [4] Multivariable control systems: An Engineering approach, P. Albertos and Sala, Springer Verlag, London, 2004
- [5] Identification and control of multivariable systems-role of relay feedback, A Ph.D Thesis, Control Engg Lab, Electrical Engg Dept., Anna University, Chennai, India, C. Selvakumar, 2009.
- [6] Rames C. Panda, 2008, Synthesis of PID controller using desired closed loop criteria, *Ind. & Engg. Chem Res.*, 47(22),1684-92
- [7] Rames C. Panda, 2009, Synthesis of PID controller for unstable and integrating processes, *Chem. Eng. Sci*, 64 (12), 2807-16

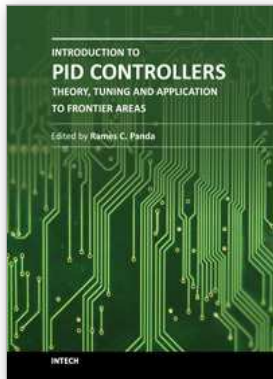

## **Introduction to PID Controllers - Theory, Tuning and Application to Frontier Areas**

Edited by Prof. Ramesh C. Panda

ISBN 978-953-307-927-1

Hard cover, 258 pages

**Publisher** InTech

**Published online** 29, February, 2012

**Published in print edition** February, 2012

This book discusses the theory, application, and practice of PID control technology. It is designed for engineers, researchers, students of process control, and industry professionals. It will also be of interest for those seeking an overview of the subject of green automation who need to procure single loop and multi-loop PID controllers and who aim for an exceptional, stable, and robust closed-loop performance through process automation. Process modeling, controller design, and analyses using conventional and heuristic schemes are explained through different applications here. The readers should have primary knowledge of transfer functions, poles, zeros, regulation concepts, and background. The following sections are covered: The Theory of PID Controllers and their Design Methods, Tuning Criteria, Multivariable Systems: Automatic Tuning and Adaptation, Intelligent PID Control, Discrete, Intelligent PID Controller, Fractional Order PID Controllers, Extended Applications of PID, and Practical Applications. A wide variety of researchers and engineers seeking methods of designing and analyzing controllers will create a heavy demand for this book: interdisciplinary researchers, real time process developers, control engineers, instrument technicians, and many more entities that are recognizing the value of shifting to PID controller procurement.

### **How to reference**

In order to correctly reference this scholarly work, feel free to copy and paste the following:

Ramesh C. Panda and V. Sujatha (2012). Identification and Control of Multivariable Systems – Role of Relay Feedback, Introduction to PID Controllers - Theory, Tuning and Application to Frontier Areas, Prof. Ramesh C. Panda (Ed.), ISBN: 978-953-307-927-1, InTech, Available from:

<http://www.intechopen.com/books/introduction-to-pid-controllers-theory-tuning-and-application-to-frontier-areas/identification-and-control-of-multivariable-systems-role-of-relay-feedback>

# **INTECH**

open science | open minds

### **InTech Europe**

University Campus STeP Ri  
Slavka Krautzeka 83/A  
51000 Rijeka, Croatia  
Phone: +385 (51) 770 447  
Fax: +385 (51) 686 166  
[www.intechopen.com](http://www.intechopen.com)

### **InTech China**

Unit 405, Office Block, Hotel Equatorial Shanghai  
No.65, Yan An Road (West), Shanghai, 200040, China  
中国上海市延安西路65号上海国际贵都大饭店办公楼405单元  
Phone: +86-21-62489820  
Fax: +86-21-62489821

© 2012 The Author(s). Licensee IntechOpen. This is an open access article distributed under the terms of the [Creative Commons Attribution 3.0 License](#), which permits unrestricted use, distribution, and reproduction in any medium, provided the original work is properly cited.