

# Functional Significance of Facilitation Between the Pronator Teres and Extensor Carpi Radialis in Humans: Studies with Electromyography and Electrical Neuromuscular Stimulation

Akira Naito<sup>1</sup>, Hiromi Fujii<sup>2</sup>, Toshiaki Sato<sup>2</sup>,  
Katsuhiko Suzuki<sup>2</sup> and Haruki Nakano<sup>1</sup>

<sup>1</sup>*Yamagata University*

<sup>2</sup>*Yamagata Prefectural University of Health Sciences  
Japan*

## 1. Introduction

Excitatory (facilitation) or inhibitory spinal reflex arcs (inhibition) mediated by group I afferent fibers from the muscle spindles (group Ia afferents) and Golgi tendon organs (group Ib afferents) among muscles in the human upper limb have been studied (Fig. 1) (Aymard et al., 1995; Baldissea et al., 1983; Cavallari & Katz, 1989; Cavallari et al., 1992; Creange et al., 1992; Day et al., 1984; Fujii et al., 2001; Katz et al., 1991; Kobayashi et al., 2000; Lourenço et al., 2007; Marchand-Pauvert et al., 2000; Miyasaka et al., 1995, 1996, 1998, 2007; Naito et al., 1996, 1998a, 2001; Naito, 2003, 2004; Nakano et al., 2005, 2006; Ogawa et al., 2005; Pierrot-Deseilligny & Mazevet, 2000; Rossi et al., 1995; Sato et al., 2002; Shinozaki et al., 2001; Suzuki et al., 2005, 2007; Wargon et al., 2006). These reflex arcs modulate motoneuron excitabilities to coordinate smooth muscular movements (Naito, 2003, 2004; Pierrot-Deseilligny et al., 1981; Rothwell, 1994; Tanaka, 1989). The facilitation must function for co-contraction of muscles and the inhibition for alternating or reciprocal contraction among muscles (Naito, 2003, 2004).

Musculus (m.) pronator teres (PT) arises from the medial epicondyle of the humerus (humeral head) and the coronoid process of the ulna (ulnar head) and attaches on the lateral surface of the shaft of the radius (Basmajian, 1982; Jenkins, 2008; Standring et al., 2005). It is innervated by the median nerve. M. extensor carpi radialis longus (ECRL) arises mainly from the distal third of the supracondylar ridge of the humerus and attaches to the radial side of the dorsal aspect of the base of the second metacarpal. M. extensor carpi radialis brevis (ECRB) arises mainly from the lateral epicondyle of the humerus and attaches on the radial side of the base of the third metacarpal. Both muscles (ECR) are innervated by the radial nerve. Most textbooks of anatomy describe that PT acts as a forearm pronator and ECR as a wrist extensor and abductor. Our previous studies have demonstrated facilitation between PT and ECR (ECRL, ECRB) in humans (Fig. 1) (Nakano et al., 2005, 2006). The facilitation seems to be mediated by group Ia afferents through a monosynaptic path. It is known that monosynaptic facilitation mediated by group Ia afferents is usually observed

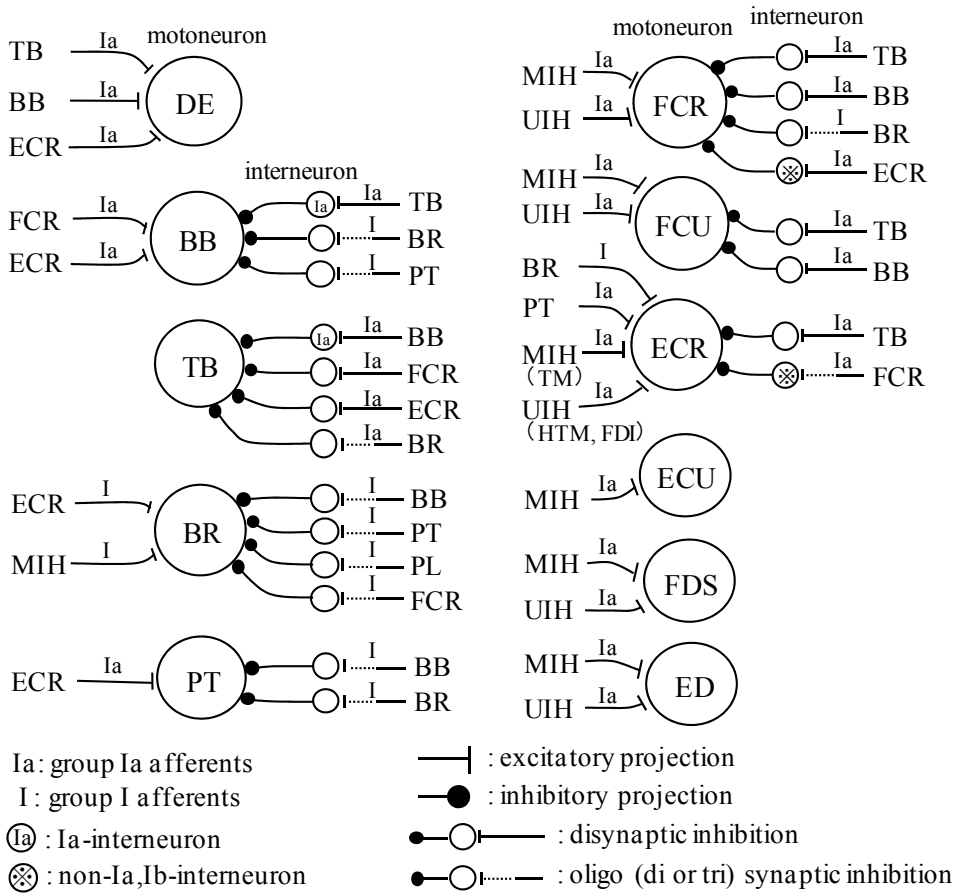

Fig. 1. Excitatory (facilitation) and inhibitory spinal reflex arcs (inhibition) studied among muscles in the human upper limb (homonymous facilitation mediated by group Ia afferents and homonymous inhibition mediated by group Ib afferents are omitted). The facilitation is illustrated on the motoneuron's left, the inhibition on the right. DE: musculus (m.) deltoideus (anterior fibers), BB: m. biceps brachii, TB: m. triceps brachii, BR: m. brachioradialis, PT: m. pronator teres, PL: m. palmaris longus, ECR: m. flexor carpi radialis, FCU: m. flexor carpi ulnaris, ECR: mm. extensor carpi radialis longus and brevis, ECU: m. extensor carpi ulnaris, FDS: m. flexor digitorum superficialis, ED: m. extensor digitorum, MIH: hand muscles innervated by the median nerve, UIH: hand muscles innervated by the ulnar nerve, TM: thenar muscles, HTM: hypothnar muscles, FDI: m. interosseus dorsalis prima, Abbreviations in this as well as Figs. 2-7.

among synergistic muscles (Naito, 2003, 2004; Pierrot-Deseilligny et al., 1981; Tanaka, 1989). However, since PT and ECR are not synergistic, the functional significance of the facilitation is still unclear. This chapter describes the significance elucidated by studies using an electromyography (EMG) and electrical neuromuscular stimulation (ENS).

## 2. EMG study

Observations of activities of two muscles during repetitive movements must reveal activation of facilitation or inhibition between them. The facilitation must be active during co-contraction of the muscles and the inhibition must be during alternating or reciprocal contraction between the muscles. Since PT belongs to forearm pronators and ECR (ECRL, ECRB) to wrist extensors, activities of the muscles during repetitive movements of dynamic forearm pronation/supination, and those of static (isometric) wrist extension and dynamic wrist extension/flexion were studied using EMG.

For EMG recording, bipolar intramuscular electrodes made of teflon-coated stainless steel wire (75  $\mu$ m in diameter, SUS 316, AM system, Carlsborg WA, USA) with distance of about 4 mm were used (Basmajian & Deluca, 1985; Fujii et al., 2007; Naito et al., 1998b; Perotto, 1994). The electrodes were implanted percutaneously into the muscles with 25 gauge-injection needles (Naito et al., 1998b, Riek et al., 2000). A wet bandage was put round the shoulder and used as reference. EMGs were amplified, band pass filtered (10-1,000 Hz), and sampled at 2,048 Hz. Then they were integrated (rectified and averaged) with an EMG integration program (Multi-Computer System, Giga Tex Co., Osaki, Japan).

### 2.1 The repetitive movements of dynamic forearm pronation/supination

EMGs of m biceps brachii (BB), PT, ECRL, ECRB, m. extensor carpi ulnaris (ECU), and m. flexor carpi ulnaris (FCU) were recorded in five normal subjects (male, age range 23-46 years). Movements tested were repetitive movements of dynamic forearm pronation/supination between the maximum prone (90 degrees of pronation) and spine positions (90 degrees of supination) with maintenance of the wrist neutral position (0 degrees of flexion/extension, 0 degrees of adduction/abduction). The subject sat on a chair with the shoulder joint flexed to 0 degrees of flexion and the elbow joint flexed to 90 degrees of flexion (Fig. 2A). In order to obtain adequate EMGs of the muscles (Basmajian and Deluca, 1985; Naito et al., 1998b), a belt weighing 1.0-2.0 kg was wound around the hand (palm) as a load. The movements were pictured with three digital video cameras (NW-GS 100, Panasonic, Tokyo, Japan) (anterior, superior, and medial aspects). Trajectories of the styloid process of the radius during the movements were traced using a 3-D-position sensor (3DPS) system (Liberty, POLHEMUS, USA), which delivered coordinate (x, y, z). A terminal probe of the 3DPS system was put on the skin of the styloid process with adhesive tape. Lissajou's curves (trajectories in the coronary plane) was drawn with the data (x, y) using a 2-D Lissajou presentation program (RO299-4588G, Gigatex, Osaki, Japan). Video pictures and data of the 3DPS system were fed into a simultaneous recording system of digital video pictures and electric signals (The Teraview, Gigatex, Osaki, Japan) with EMGs (Sagae et al., 2010; Sato et al., 2007).

During the movements, BB showed activities increasing and decreasing and PT, ECRL, and ECRB parallel activities decreasing and increasing at the supination and pronation phases, respectively, in all the five subjects (Fig. 2B, C). These fluctuations resulted in peaks and troughs of BB activities, and troughs and peaks of PT, ECRL, and ECRB activities at the maximum supination and pronation, respectively (Table 1). ECU showed parallel activities to PT, ECRL, and ECRB activities in all the subjects and those to BB activities (Fig. 2C) in two subjects. Peaks of the parallel activities of the latter were much lower than those of the former. FCU showed parallel activities to BB activities in three subjects (Fig 2B). In one subject, large and regular activities of which peaks followed the peaks of BB activities and

small irregular activities were observed (Fig. 2C). In the remaining one subject, FCU showed no activities during the movements.

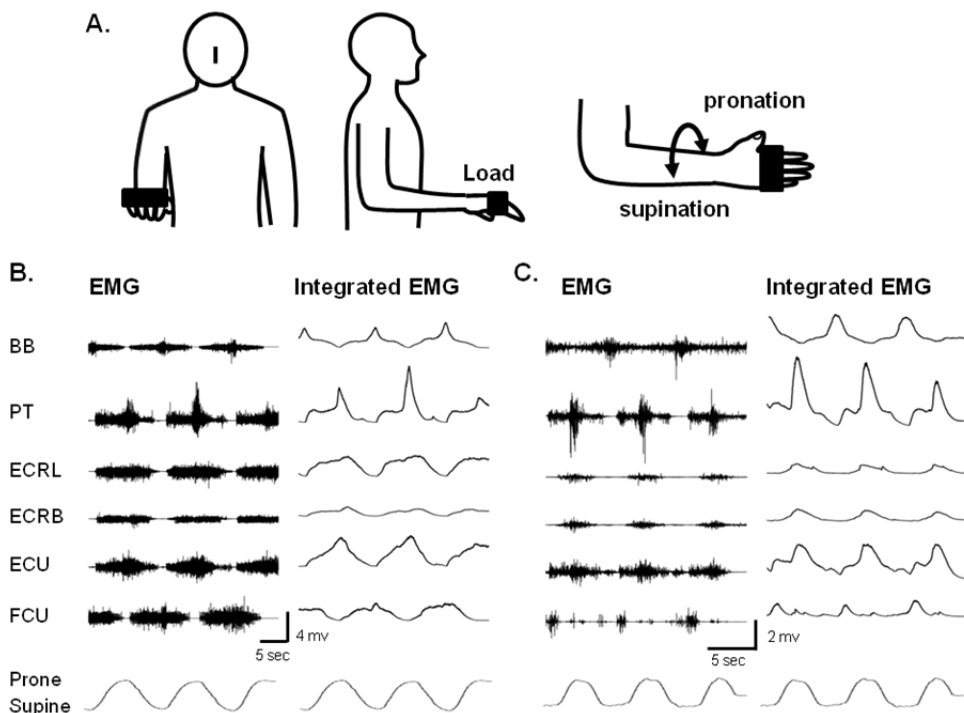

Fig. 2. An electromyographic (EMG) study of repetitive movements of dynamic forearm pronation/supination with maintenance of wrist neutral position in normal human subjects. **A:** The posture of the subject. During the experiment, the subject sits on a chair and keeps the shoulder joint at 0 degrees of flexion/extension, adduction/abduction, and external/internal rotation, the elbow joint at 90 degrees of flexion, and the wrist joint at 0 degrees of flexion/extension and adduction/abduction (neutral position). In order to evoke adequate EMG activities, a belt weighing 1.0-2.0 kg is surrounded around the hand. **B, C:** EMGs of BB, PT, ECRL, ECRB, ECU, and FCU during the movements in two subjects. The bottom solid lines indicate changes in the position of the forearm. Note that parallel activities of ECRL, ECRB, and PT increasing and decreasing at the pronation and supination phases, respectively, are observed in both the subjects.

Among BB, PT, ECR (ECRL, ECRB), ECU, and FCU in humans, facilitation between PT and ECR (Nakano et al., 2005, 2006), and from ECR to BB (Cavallari & Katz, 1989) and inhibition between BB and PT (Miyasaka et al., 1996; Naito et al., 1998a), and from BB to FCU (Cavallari et al., 1992) have been studied (Fig. 1). The EMG study showed that activities of BB increased and decreased and those of PT and ECR decreased and increased at the supination and pronation phases, respectively, in all the five subjects. This observation suggests that reciprocal contraction between BB and PT, and BB and ECR, and co-contraction of PT and ECR occur during the movements. The inhibition between BB and PT

	Peaks		Troughs	
	MaxS	MaxP	MaxS	MaxP
BB	5	0	0	5
PT	0	5	5	0
ECRL	0	5	5	0
ECRB	0	5	5	0
ECU	0	5	5	0
FCU	3	0	0	4

MaxS: the maximum supination, MaxP: the maximum pronation, BB: musculus (m.) biceps brachii, PT: m. pronator teres, ECRL: m. extensor carpi radialis longus, ECRB: m. extensor carpi radialis brevis, ECU: m. extensor carpi ulnaris, FCU: m. flexor carpi ulnaris, Abbreviations in this as well as Tables 2, 3.

Table 1. Peaks and troughs of activities of muscles during repetitive movements of dynamic forearm pronation/supination with maintenance of the wrist neutral position in five subjects.

(Miyasaka et al., 1996; Naito et al., 1998a) must be active during the reciprocal contraction and the facilitation between PT and ECR (Nakano et al., 2005, 2006) must be during the co-contraction. The facilitation must work effectively for the parallel activities increasing at the pronation phase. The facilitation from ECR to BB (Cavallari & Katz, 1989) seems to be inactive during the movement. In the EMG study, parallel activities of ECU to PT and ECR activities and BB activities were seen in all and two subjects, respectively. The parallel activities of the latter were much smaller than those of the former. These results suggest that co-contraction of PT, ECR, and ECU, and reciprocal contraction between BB and ECU occur during the movement. The EMG study also showed that parallel activities of FCU to BB activities were observed in three subjects and activities of FCU of which peaks followed the peaks of BB activities in one subject. This observation suggests that co-contraction of BB and FCU, and reciprocal contraction between FCU and PT, and FCU and ECR occur during the movements. The inhibition from BB to FCU (Cavallari et al., 1992) seems to be inactive during the movements. Observations of the co-contraction and reciprocal contraction suggest a possibility that facilitation between PT and ECU, and ECR and ECU, and inhibition between PT and FCU, ECR and FCU, and ECU and FCU exist in humans. Further studies are required to elucidate existences of the facilitation and inhibition.

**2.2 The repetitive movements of static wrist extension and dynamic wrist extension/flexion**

EMGs of PT, ECRL, ECRB, and FCR were recorded in twelve normal human subjects (male 9, female 3, age range 20-40 years) (Fujii et al., 2007). EMGs were fed into a data recorder (RECTI-HORIZ-8K, NEC, Tokyo, Japan) and pen recorder (RCD-928, Shinko, Tokyo, Japan). Movements tested were repetitive movements of static (isometric) wrist extension and dynamic wrist flexion/extension in the prone (about 80 degrees of pronation), semiprone (neutral), and supine positions (about 80 degrees of supination) of the forearm (Fig. 3A). The subject sat on a chair and put the forearm on an experimental table with the shoulder joint flexed to 0-20 degrees of flexion and the elbow joint flexed to 70-90 degrees of flexion (Fig. 3A). In the movements of the static wrist extension, the subject made an effort to extend the wrist in the position of 0-20 degrees of extension against resistance for about 5 sec. The

resistance was produced by the experimenter's hand. The hand pressed the dorsum of the subject's hand to prevent the wrist from extending. The effort was performed 3-5 times at interval of about 5 sec. In the movements of the dynamic wrist flexion/extension, the subject performed a to-and-fro motion from the maximum flexion to the maximum extension of the wrist 5 times for about 25 sec. Angular changes of the wrist in flexion/extension direction were measured using an electrogoniometer (PH510, Denkikeisoku Hanbai, Tokyo, Japan). Data of the angular changes were fed into the data recorder and pen recorder with EMGs.

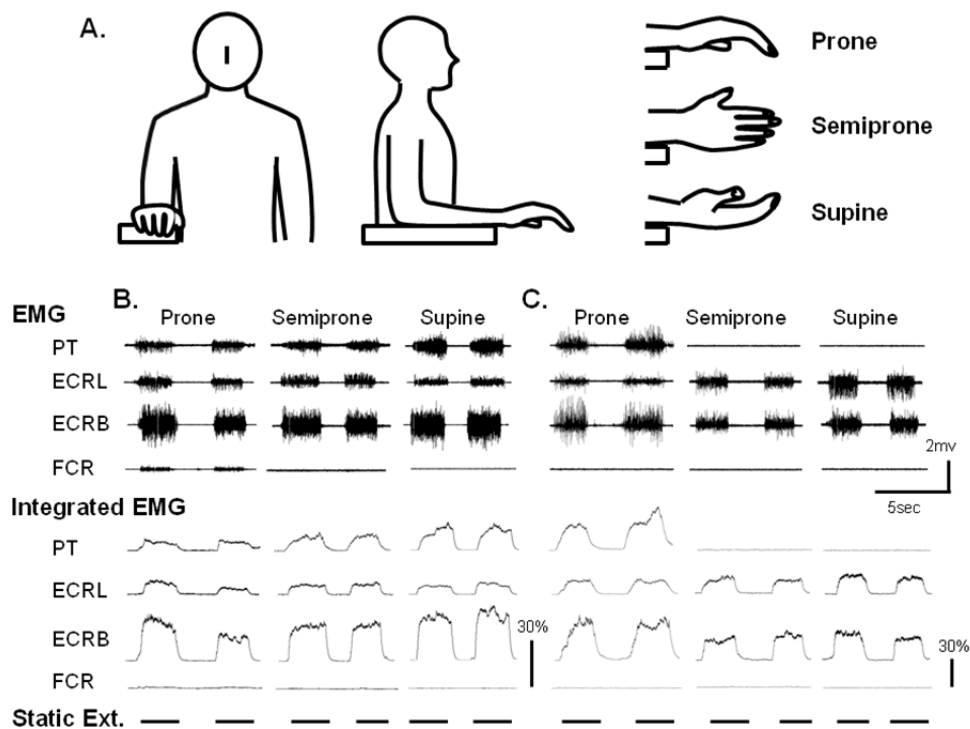

Fig. 3. An EMG study of repetitive movements of static (isometric) wrist extension with maintenance of the forearm in the prone, semiprone (neutral), and supine positions in normal human subjects. **A:** The posture of the subject. During the experiment, the subject sits on a chair and puts the pronated, semipronated, and supinated forearm on an experimental table with the shoulder joint at 0-20 degrees of flexion/extension, 0 degrees of adduction/abduction, and external/internal rotation, the elbow joint at 70-90 degrees of flexion. Static wrist extension is performed against the resistance produced by the experimenter's hand. **B, C:** EMGs of ECRL, ECRB, PT, and FCR during the movements in two subjects. The bottom thick lines indicate the period of the extension. Parallel activities of PT, ECRL, and ECRB are observed in the prone, semiprone, and supine positions in one subject (**B**) and in the prone position in another (**C**). Calibration bars for integrated EMGs: a percentage of the amplitude produced by the maximum contraction. Reproduced with permission from Fujii et al. (2007).

During the movements of the static wrist extension, ECRL and ECRB showed activities in the prone, semiprone, and supine positions of the forearm in all the twelve subjects (Table 2, Fig. 3B, C). Slight or no activities were seen in FCR. PT showed activities in the prone, semiprone, and supine positions in all, eight, and eight subjects, respectively. The activities were parallel with those of ECRL and ECRB. In the remainders, PT showed no activities during the movements.

During the movements of the dynamic wrist flexion/extension, activities of ECRL and ECRB increased at the extension phase and those of FCR at the flexion phase in all the twelve subjects (Fig. 4). Therefore peaks of the activities of ECRL and ECRB appeared at the extension phase and those of FCR at the flexion phase (Table 3). Activities of PT increased at the extension phase in all, eight and five subjects, respectively, and at the flexion phase in zero, four, and five subjects, respectively, in the prone, semiprone, and supine positions. In three subjects (YE, SY, SK in Table 3), the activities increased at both the extension and flexion phases in the semiprone and supine positions. The activities of PT at the extension and flexion phases were parallel with those of ECRL and ECRB, and FCR (Fig. 4A), respectively.

Subject	Prone				Semiprone				Supine			
	ECRL	ECRB	PT	FCR	ECRL	ECRB	PT	FCR	ECRL	ECRB	PT	FCR
K.S.	+	+	+	-	+	+	+	+	+	+	-	-
Y.E.	+	+	+	-	+	+	-	-	+	+	-	-
H.F.	+	+	+	-	+	+	-	-	+	+	-	-
M.S.	+	+	+	-	+	+	-	-	+	+	-	-
K.S.	+	+	+	-	+	+	+	-	+	+	+	-
S.Y.	+	+	+	+	+	+	+	-	+	+	+	-
H.T.	+	+	+	-	+	+	+	+	+	+	+	-
Y.K.	+	+	+	-	+	+	-	+	+	+	+	-
A.M.	+	+	+	-	+	+	+	-	+	+	+	+
Y.U.	+	+	+	-	+	+	+	-	+	+	+	-
S.K.	+	+	+	+	+	+	+	+	+	+	+	-
Y.W.	+	+	+	-	+	+	+	-	+	+	+	-

FCR: m. flexor carpi radialis. Abbreviations in this as well as Table 3.

Table 2. Activities of muscles during repetitive movements of static wrist extension in twelve subjects.

Among PT, ECR, and FCR in humans, inhibition between ECR and FCR (Aymard et al., 1995; Baldissera et al., 1983; Day et al., 1984), and facilitation between PT and ECR (Nakano et al., 2005, 2006) have been studied (Fig. 1). In the EMG study, during the repetitive movements of the dynamic wrist flexion/extension ECR (ECRL and ECRB) and FCR showed increments of activities at the extension and flexion phases, respectively, regardless of the positions of the forearm in all the subjects. Therefore alternating contraction between the muscles occurred during the movements. The inhibition between ECR and FCR (Aymard et al., 1995; Baldissera et al., 1983; Day et al., 1984) must be active during the alternating contraction. In the EMG study, in the prone, semiprone, and supine positions of the forearm, PT and ECR showed parallel activities during the movements of the static wrist extension in all, eight, and eight subjects and at the extension phase of the movements of the dynamic wrist extension/flexion in all, eight and five subjects, respectively. Therefore co-contraction of the muscles occurred during the wrist extension movements at least with the prone forearm. The facilitation between PT and ECR (Nakano et al., 2005, 2006) must be

Subject	Prone				Semiprone				Supine			
	ECRL	ECRB	PT	FCR	ECRL	ECRB	PT	FCR	ECRL	ECRB	PT	FCR
K.S.	E	E	E	F	E	E		F	E	E		F
Y.E.	E	E	E	F	E	E	E	F	E	E	E	F
H.F.	E	E	E	F	E	E		F	E	E		F
M.S.	E	E	E	F	E	E	E	F	E	E		F
K.S.	E	E	E	F	E	E	E	F	E	E		F
S.Y.	E	E	E	F	E	E	E	F	E	E	E	F
H.T.	E	E	E	F	E	E		F	E	E		F
Y.K.	E	E	E	F	E	E	E	F	E	E	E	F
A.M.	E	E	E	F	E	E	E	F	E	E		F
Y.U.	E	E	E	F	E	E		F	E	E		F
S.K.	E	E	E	F	E	E	E	F	E	E	E	F
Y.W.	E	E	E	F	E	E	E	F	E	E	E	F

E: extension phase, F: flexion phase

Table 3. Peaks of activities of muscles during repetitive movements of dynamic wrist flexion/extension in twelve subjects.

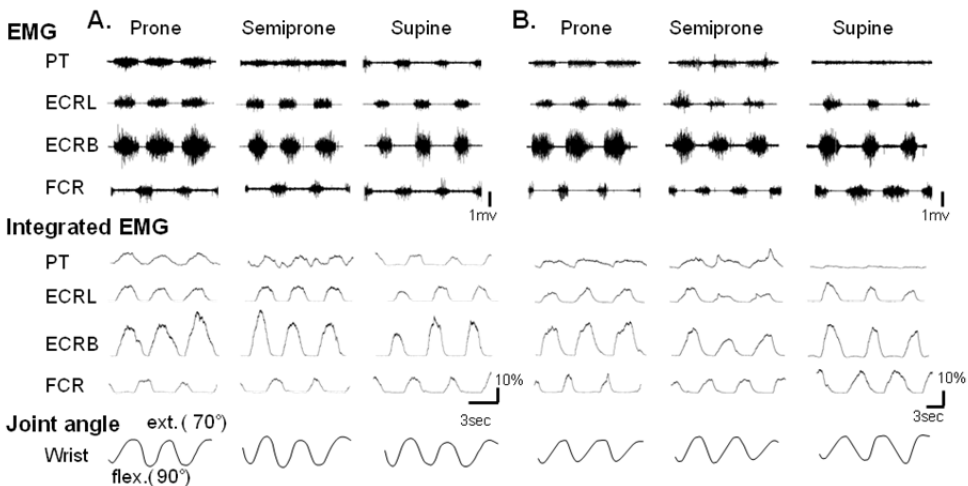

Fig. 4. An EMG study of repetitive movements of dynamic wrist flexion/extension with maintenance of the forearm in the prone, semiprone (neutral), and supine positions in normal human subjects. The subject performed the movements in the posture as well as Fig. 3A. **A, B**: EMGs of ECRL, ECRB, PT, and FCR during the movements in two subjects. The bottom trace represents the position of the wrist in flexion/extension direction. Parallel activities of PT, ECRL, and ECRB are seen at the extension phase in the prone and semiprone positions in both subjects (**A, B**). PT and FCR show parallel activities at the flexion phase in the supine and semiprone positions in one subject (**A**). Calibration bars for integrated EMGs: a percentage of the amplitude produced by the maximum contraction. Reproduced with permission from Fujii et al. (2007).

active during the co-contraction. In the EMG study, during the movements of the dynamic wrist flexion/extension parallel activities of PT and FCR were seen at the flexion phase in the semiprone and supine positions in four and five subjects, respectively. This observation



of co-contraction seems to indicate existence of facilitation between PT and FCR. It therefore seems likely that the facilitation between PT and ECR is activated with pronating the forearm and that between PT and FCR is with supinating the forearm. Further studies are required to elucidate influence of the forearm position on the facilitation.

### 3. ENS study

Motions of the forearm and wrist produced by ENS to PT and ECRL were examined in the same twelve subjects of the EMG study in 2.2 (Fujii et al., 2007). The subject sat on a chair the shoulder joint flexed to 0-20 degrees of flexion and the elbow joint flexed to 70-90 degrees of flexion as well as in EMG study in 2.2 (Fig. 3A). The forearm was put on an experimental table in the prone, semiprone, and supine positions. For electrical stimulation, monopolar electrodes made of teflon-coated stainless steel wire (above-mentioned product) were implanted percutaneously into each motor point of ECRL and PT with 27 gauge injection-needles (Fujii et al., 2007; Naito et al., 1994, 2002; Sagae et al., 2010). A guide needle of a 25 gauge spinal-needle (length: 89 mm, Top Co., Tokyo, Japan) was percutaneously inserted into the subcutaneous tissue along to the lateral intermuscular septum of the arm and used as reference. Before the implantation, locations of the motor points were examined by electrical stimulation with surface electrodes. During the implantation, electrical rectangular pulses (duration: 0.2 ms, amplitude: -20-0 V, frequency: 1 or 20 Hz) were occasionally delivered to the muscles through the wire electrodes and contraction of individual muscles was confirmed by inspecting and palpating the tendon or belly of them (Albright & Linburg, 1978; Basmajian, 1982; Standring, 2005; Yoshida, 1994). Also it was carefully checked that no contraction of any other muscles was induced by the stimulation. For the ENS study, electrical rectangular pulses (duration: 0.2 ms, amplitude: -20 - 0 V, frequency: 20 Hz) were delivered using a computer-controlled multi-channel functional electrical stimulation (FES) system which we had developed to restore motor functions of paralyzed extremities with intramuscular wire electrodes (Handa et al., 1989; Hoshimiya et al., 1989). EMGs of ECRL and PT were recorded with two pairs of surface electrodes (Ag/AgCl Paste Applied with PVC Tape, Vitrode, NIHON KODEN, Tokyo, Japan), which were put on the central part of the contracted muscle belly longitudinally with the distance of about 1 cm. EMGs were amplified and band pass filtered (10-350 Hz). A wet bandage put round the shoulder was used as reference. Stimulation intensities (voltage) for the motor threshold (MT) and maximum contraction (MC) in individual muscles were determined by monitoring EMGs (motor wave) of the muscles and palpating the belly and tendon of them. In order to stimulate each of the muscles with the intensity between MT and MC, the voltage data for MT and MC were put into the FES system. Before ENS, the examined forearm was in the prone, semiprone, and supine positions. Then motions of the forearm and wrist induced by ENS were taken video with a digital video system (NV-MX2500, Panasonic, Tokyo). Angular changes of the motions of the wrist in flexion/extension direction and the forearm in pronation/supination direction were measured with the electrogoniometers mentioned above. A motion of the wrist in abduction/adduction direction was checked with video pictures. During ENS, EMGs of PT and ECRL were recorded with the pairs of the surface electrodes mentioned above. Data of the angular changes and EMGs were fed into the data recorder and pen recorder. ENS to ECRL was examined in all the twelve subjects. Since ENS to PT resulted in activation of PT and the other muscles innervated by the median nerve, i.e. FCR, m. palmaris longus, in one subject, it was examined in the remaining eleven subjects. The stimulus intensity was increased linearly from MT to MC for 4-5 sec.

ENS to PT induced a motion of forearm pronation from the prone, semiprone, and supine positions to the maximum pronation (90 degrees of pronation) in all the eleven subjects. ENS to ECRL induced motions of wrist extension to the maximum extension (70 degrees of extension) and abduction (radial flexion) to 5-20 degrees of abduction regardless of the positions of the forearm in all the twelve subjects. When the forearm was pronated before ENS, 30-80 degrees supination of the forearm from the prone position was induced in all the twelve subjects (Fig. 5).

Combined ENS to PT and ECRL was examined in the eleven subjects. An increase of the stimulus intensity of ENS to PT from MT to MC fixed the forearm in the maximum pronation (Fig. 6). Then an increase for ENS to ECRL from MT to MC resulted in motions of wrist extension to the maximum extension and abduction to 5-20 degrees of abduction without a motion of supination in all the eleven subjects. In this situation, a decrease of the intensity of ENS to PT from MC to MT resulted in a motion of 40-90 degrees supination from the maximum pronation while holding the wrist extension and abduction. Then the increase of the intensity of ENS to PT from MT to MC resulted in a motion of pronation to the maximum pronation while holding the extension and abduction (Fig. 6D).

#### **4. Functional significance of the facilitation between PT and ECR**

The ENS study showed that ENS to PT produced forearm pronation from the prone, semiprone, and supine positions to the maximum prone position and that to ECRL wrist extension to the maximum extension and abduction to 5-20 degrees of abduction in the forearm prone, semiprone, and supine positions in all subject. These results suggest that PT acts as a forearm pronator and ECRL as a wrist extensor and abductor independent of the forearm position. The EMG study of the repetitive movements of dynamic forearm pronation/supination with maintenance of the wrist neutral position showed parallel activities of PT, ECRL, and ECRB increasing and decreasing at the pronation and supination phases, respectively, in all subject. This result suggests that the facilitation between PT and ECR is active during the co-contraction and works effectively at the pronation phase of the movements. Since at the pronation phase pronating force of PT must be used to pronate the forearm and extending and abducting force of ECR must be to support the weight of the hand, the facilitation seems to be convenient for maintenance of the wrist position.

The ENS study showed that ENS to ECRL produced 30-80 degrees forearm supination from the prone position in all subject. This result suggests that ECRL act as not only a wrist extensor and abductor but also a forearm supinator when the forearm is in the prone position. Hence forearm supination from the prone position should be added to one of the actions of ECRL. The EMG study showed parallel activities of PT, ECRL, and ECRB during the movements of static wrist extension and at the extension phase of the movements of dynamic wrist extension/flexion in the prone position of the forearm in all subject. This result suggests that co-contraction of PT and ECR occurs during both static and dynamic wrist extension movements at least with the prone forearm. The facilitation must be active during the co-contraction. Since during the wrist extension movements extending and abducting force of ECRL must be used to extend the wrist and pronating force of PT must be to counteract supinating force of ECRL, the facilitation seems to be very convenient for maintenance of the forearm position. Actually the ENS study confirmed that combined ENS to PT and ECRL resulted in wrist extension and abduction with maintenance of the forearm prone position. The results of the EMG and ENS studies suggest that the facilitation is between antagonistic muscles. It is of no ordinary type.

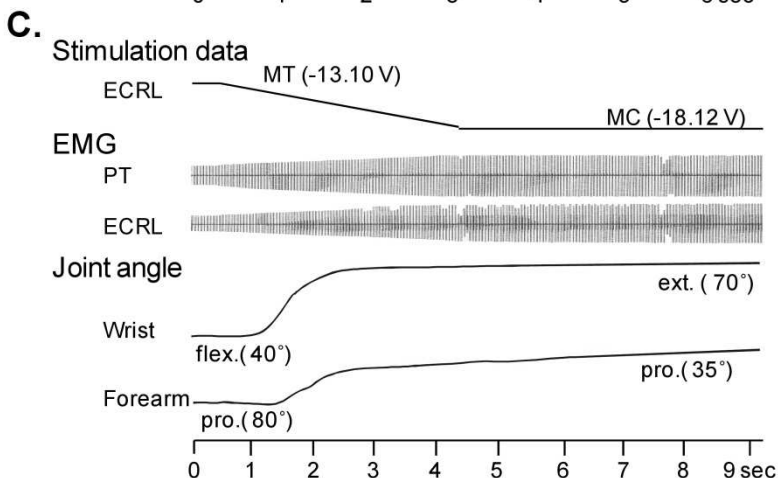
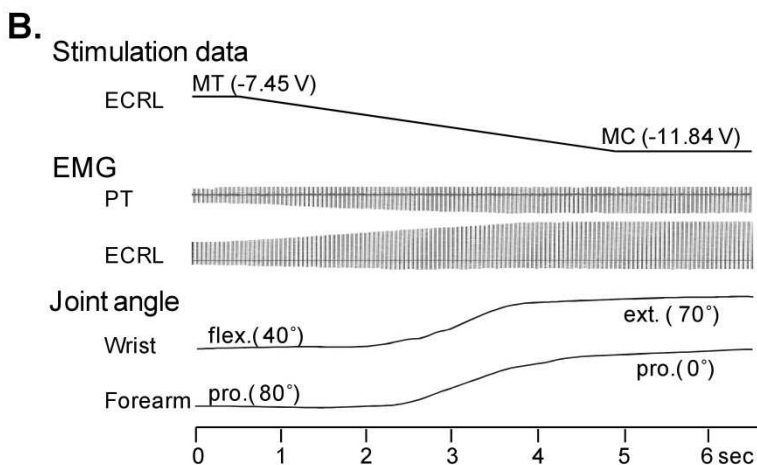

Fig. 5. An electrical neuromuscular stimulation (ENS) study: Motions produced by ENS to ECRL in normal human subjects. **A:** Pictures showing a sequence of the motions in a subject at 0.5-1 s interval. Before ENS (0 s), the forearm is in the prone position. Motions of wrist

extension and abduction (radial flexion), and forearm supination are induced (1-6.5 s). **B, C:** Results in two subjects, of which one (**B**) is of the subject in **A**. Prior to ENS, the forearm in the prone position. The stimulation intensities increased linearly from the motor threshold (MT) to the maximum contraction (MC) for 4.5 s in **B** and 4 s in **C**. Motions of wrist extension from 40 degrees of flexion to 70 degrees of extension and forearm supination from 80 to 0 degrees of pronation are induced in **B** and those of extension from 50 degrees of flexion to 70 degrees of extension and supination from 80 to 35 degrees of pronation are in **C**. No voluntary contraction of ECRL and PT are observed in EMG in both subjects (**B, C**). Abbreviations in this as well as Fig. 6. Reproduced with permission from Fujii et al. (2007).

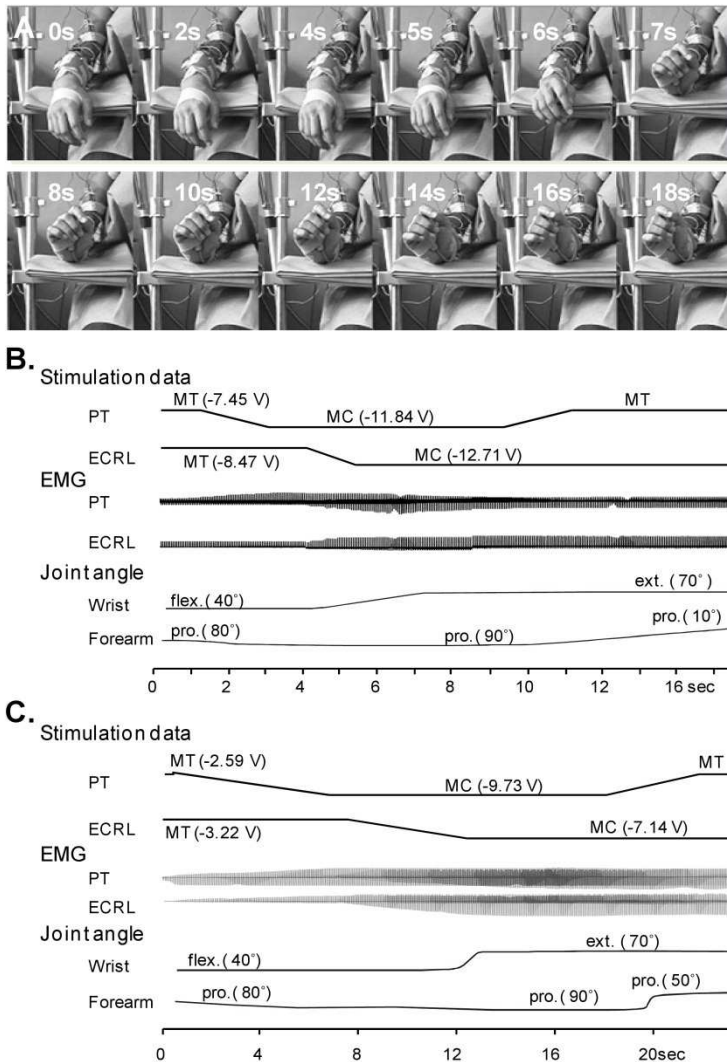

Fig. 6. (Continued)

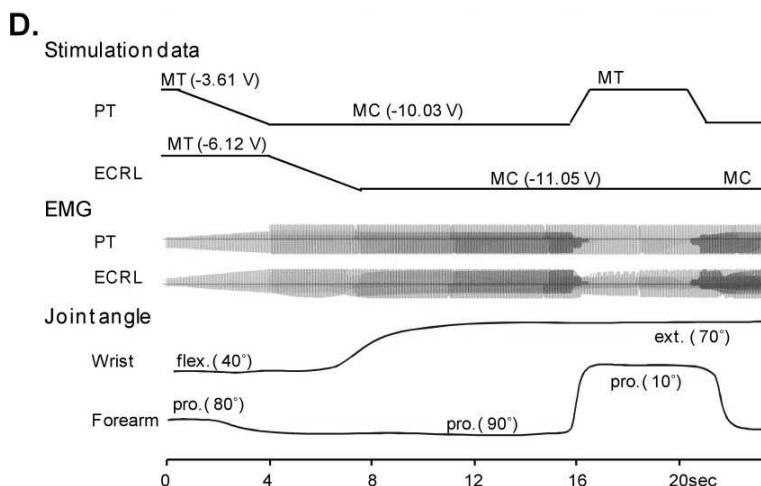

Fig. 6. An ENS study: Motions produced by a combined ENS to PT and ECRL in normal human subjects. **A**: Pictures showing a sequence of the motions in one subject at 1-2 s interval. Before ENS (0 s), the forearm is in the prone position. ENS to PT induces a motion of pronation to the maximum pronation of the forearm (1-4 s). Then ENS to ECRL produces a motion of wrist extension and abduction with maintenance of the maximum pronation (4-8 s). Then a reduction of ENS to PT results in a motion of supination with maintenance of the extension and abduction (8-18 s). **B-D**: Results in three subjects, of which one (**B**) is of the subject in **A**. In all the three subjects (**B-D**), an increase of the stimulation intensity of ENS to PT from MT to MC induces a motion of pronation from 80 to 90 degrees of pronation (from the prone position to the maximum pronation). Then an increase of the intensity of ENS to ECRL from MT to MC induces a motion of wrist extension from 40 degrees of flexion to 70 degrees of extension (the maximum extension) with maintenance of the maximum pronation. Then a decrease of the intensity of ENS to PT from MC to MT results in a motion of supination from the maximum supination to 10 (**B**), 50 (**C**), and 10 degrees of pronation (**D**) with maintenance of the maximum extension. In one subject (**D**), then an increase of the intensity of ENS to PT induces a motion of pronation to the maximum pronation with maintenance of the maximum extension. No voluntary contraction is observed in EMG in all the subjects (**B-D**). Reproduced with permission from Fujii et al. (2007).

### 5. Effects of wrist extension and flexion on forearm supinating force

It is known that FCR acts as not only a wrist flexor and abductor but also a forearm pronator (American Society for Surgery of the Hand, 2011; Basmajian, 1982). The ENS study has shown that ECRL acts as a wrist extensor and abductor and a forearm supinator when the forearm is in the prone position (Fujii et al., 2007). It therefore is support an idea that forearm supinating force is increased and decreased by wrist extension and flexion, respectively.

Our previous study showed effects of wrist extension and flexion on forearm supinating force in humans (Otaki et al., 2009). In our study, the forces produced by maximal supination with the wrist relaxed (R-Sup), maximally flexed (F-Sup), and maximally

extended (E-Sup) in the forearm 90° (prone), 60°, 30°, and 0° pronated (neutral) positions were measured in eight normal human subjects (male 7, female 1, age range 20-41 years). Also activities of BB, which acts as an elbow flexor and forearm supinator, FCR, and ECR (ECRL and ECRB) were recorded with EMG using surface electrodes. In the EMG study, FCR and ECR respectively showed activities during wrist flexion and extension (Fig. 7A, B). BB showed activities increasing concomitantly with increased the force. Usually, E-Sup produced larger BB activities than R-Sup and F-Sup; and F-Sup decreased FCR activities and increased ECR activities. In the force study, the respective force of R-, F-, and E-Sup decreased with changing position from prone to neutral. Assuming the force of R-Sup in each position as 100%, that of E-Sup was 163±20% (mean ±S.D.), 142±17%, 134±15%, and 118±23%, and those of F-Sup was 81±7%, 90±14%, 78±13%, and 80±10%, respectively, in the prone, P60°, P30°, and neutral positions (Fig. 7C). In every position, the force of E-Sup was larger and that of F-Sup was smaller than that of R-Sup. The increment of the force of E-Sup decreased with changing the position from prone to neutral.

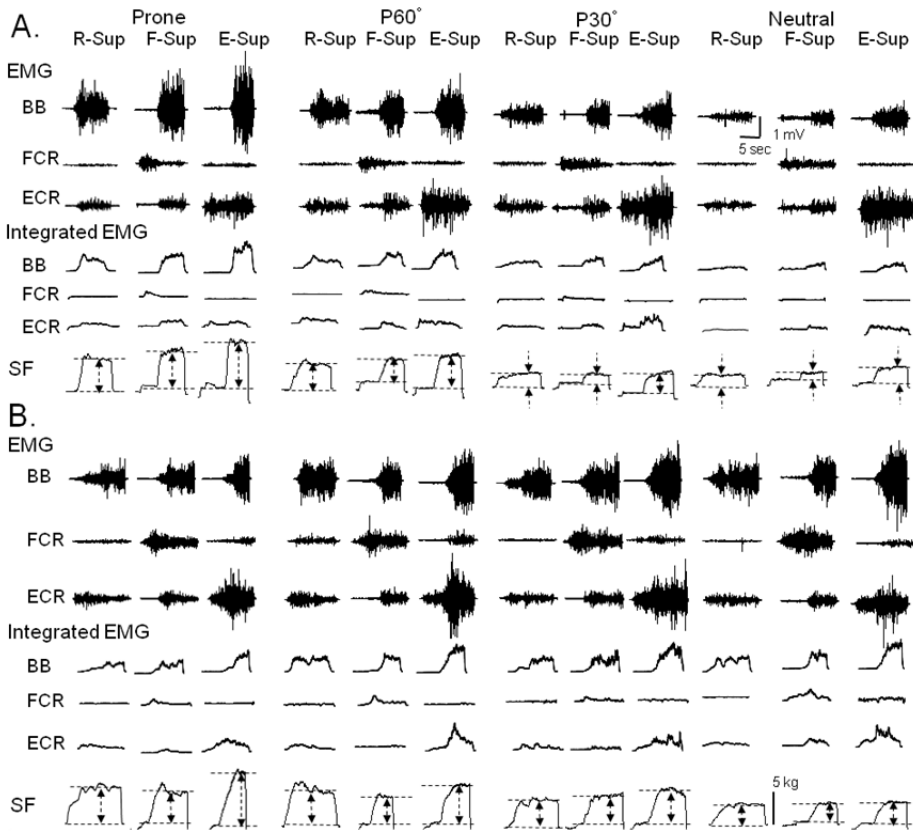

Fig. 7. (Continued)

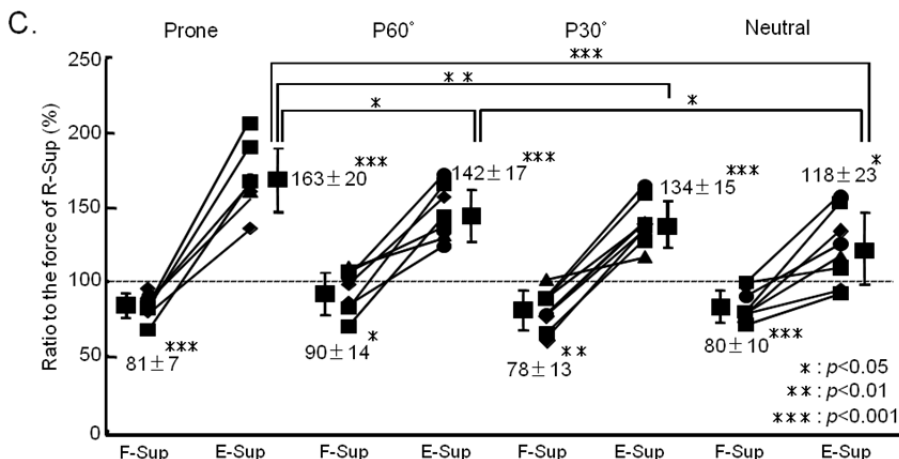

Fig. 7. Effects of wrist extension and flexion on forearm supinating force (SF) in normal human subjects. **A, B:** EMGs of BB, FCR, and ECR, and SF during maximal forearm supination with the wrist relaxed (R-Sup), maximally flexed (F-Sup), and maximally extended (E-Sup) in the forearm 90 degrees (Prone), 60 degrees (P60°), and 30 degrees (P30°), and 0 degrees (Neutral) positions in two normal human subjects. SF is indicated by the length of double broken arrow or the distance between two broken arrows. In every forearm position, E-Sup produces larger BB activities than R- and F-Sup. A decrease of FCR activities and an increase of ECR activities are observed during F-Sup. **C:** A graph showing ratio (%) of SF of F- and E-Sup to that of R-Sup in the forearm Prone, P60°, P30°, and Neutral positions in eight subjects. Individual data of the ratio of SF, and average and standard deviation are illustrated in the graph. In every position, SF of E-Sup is larger and that of F-Sup is smaller than that of R-Sup. Note that the increment of SF of E-Sup decreases with the forearm position from Prone to Neutral. Reproduced with permission from Otaki et al. (2009).

The results of the force study suggest that the supinating force is reinforced by the extension and weakened by the flexion and the reinforcement effect decreases with supination of the forearm. Since reflex arcs of facilitation from ECR to BB, inhibition between FCR and ECR, and from BB to FCR exist in humans (Fig. 1) (Aymard et al., 1995; Baldissera et al., 1983; Cavallari & Katz, 1989; Cavallari et al, 1992), the results of the EMG study suggest that the effects result not only from actions of the muscles but also from activations of the reflex arcs. Our recent study further showed an increase and decrease of forearm pronating force by wrist flexion and extension, respectively, in humans (Sato et al., 2011).

## 6. Summary

The functional significance of facilitatory spinal reflex arcs (facilitation) between musculus (m.) pronator teres (PT) and m. extensor carpi radialis (ECR; ECR longus: ECRL, ECR brevis: ECRB) in humans was studied using an electromyography (EMG) and electrical neuromuscular stimulation (ENS). The EMG study of dynamic forearm pronation/supination movements with maintenance of the wrist neutral position (PS-movements) showed parallel activities (co-contraction) of PT and ECR increasing and decreasing at the

pronation and supination phases, respectively. The facilitation must be active during the co-contraction and work effectively at the pronation phase. The EMG study of static and dynamic wrist extension movements with the prone forearm (WE-movements) also showed co-contraction of the muscles. The facilitation must be active during the co-contraction. The ENS study showed that ENS to PT produced forearm pronation and that to ECRL wrist extension and abduction independent of the forearm position. Since at the pronation phase of the PS-movements pronating force of PT must be used to pronate the forearm and extending and abducting force of ECR must be to support the weight of the hand, the facilitation seems to be convenient for maintenance of the wrist position. The ENS study also showed that ENS to ECRL produced forearm supination from the prone position. This result suggests that ECRL acts as not only a wrist extensor and abductor but also a forearm supinator when the forearm is in the prone position. Since during the WE-movements extending force of ECR must be used to extend the wrist and pronating force of PT must be to counteract supinating force of ECR, the facilitation seems to be convenient for maintenance of the forearm position. The results of EMG and ENS studies suggest that the facilitation is between antagonistic muscles. Finally, an increase and decrease of forearm supinating force respectively by wrist extension and flexion were briefly described.

## 7. Acknowledgment

The authors thank Dr. Takuji Miyasaka, Dr. Shinji Kobayashi, Dr. Katuhiro Shinozaki, Dr. Masaaki Sagae, Dr. Aya Narita, Mr. Makoto Nagamuma, Mr. Hiroto Kobayashi, Mr. Wataru Hashizume, Ms. Saori Yoshida, Mr. Katsuhiko Kato, and Mr. Inazo Eguchi for their excellent assistance. Thanks are also tendered to students of Yamagata University School of Medicine and Yamagata Prefectural University of Health Sciences for their helpful cooperation. This study was supported, in part, by a Grant-in-Aid from Japanese Ministry of Education, Science, Sport and Culture (17590146) and by grants from the Yamagata Health Support Society Foundation.

## 8. References

- Albright, J.A. & Linburg, R.M. (1978) Common variations of the radial extensors. *J Hand Surg*, Vol. 3, pp.134-138, ISSN 1531-6564
- American Society for Surgery of the Hand (2011) *The electric textbook of hand surgery. Anatomy of the hand. Muscles*. E-HAND. COM, <http://www.eatonhand.cpm/hom/hom033.htm>
- Aymard, C.; Chia, L.; Katz R.; Lafitte, C. & Penicaud, A. (1995) Reciprocal inhibition between wrist flexors and extensors in man: a new set of interneurons? *J Physiol (Lond)*, Vol. 487, pp.221-235, ISSN 0022-3751
- Baldissera, F.; Campadelli, P. & Cavallari, P. (1983) Inhibition of H-reflex in wrist flexors by group I afferents in the radial nerve. *Electromyogr Clin Neurophysiol*, Vol.23, pp.187-193, ISSN 0301-150X
- Basmajian, J.V. (1982) *Primary Anatomy* (8th Ed.), Williams and Wilkins, ISBN 0-683-00550-2, Baltimore, pp 150-164
- Basmajian, J.V. & DeLuca, C.J. (1985) *Muscle Alive: Their Functions Revealed by Electromyography* (5th Ed.), Williams and Wilkins, ISBN 0-683-00414-X, Baltimore, pp 265-289



- Cavallari, P. & Katz, R. (1989) Pattern of projections of group I afferents from forearm muscles to motoneurons supplying biceps and triceps muscles in man. *Exp Brain Res*, Vol. 78, pp.465-478, ISSN 0014-4819
- Cavallari, P.; Katz, R. & Penicaud, A. (1992) Patterns of projections of group I afferents from elbow muscles to motoneurons supplying wrist muscles in man. *Exp Brain Res*, Vol. 91, pp. 311-319, ISSN 0014-4819
- Creange, A.; Faist, M.; Katz, R. & Panicaud, A. (1992) Distributions of heteronymous Ia facilitation and recurrent inhibition in the human deltoid motor nucleus. *Exp. Brain Res*, Vol. 90, pp. 620-624, ISSN 0014-4819
- Day, B.L.; Marsden, C.D.; Obeso, J.A. & Rorhwell, J.C. (1984) Reciprocal inhibition between the muscles of the human forearm. *J Physiol (Lond)*, Vol. 349, pp.519-534, ISSN 0022-3751
- Fujii, H.; Kobayashi, S.; Shinozaki, K.; Naito, A.; Sato, T.; Miyasaka, T. & Shindo, M. (2001) Inhibitory projections of muscle afferents between the brachioradialis and flexor carpi radialis in humans. *Neurosci Res*, Suppl 25, S87, ISSN 0168-0102
- Fujii, H.; Kobayashi, S.; Sato, T.; Shinozaki, K. & Naito, A. (2007) Co-contraction of the pronator teres and extensor carpi radialis during wrist extension movements in humans. *J Electromyogr Kinesiol*, Vol. 17, pp.80-89, ISSN 1050-6411
- Handa, Y.; Hoshimiya, N.; Iguchi, Y. & Oda, T. (1989) Developments of percutaneous intramuscular electrode for multi-channel FES system. *IEEE Trans Biomed Eng*, Vol. 36; pp.705-710, ISSN0018-9294
- Hoshimiya, N.; Naito, A.; Yajima, M. & Handa, Y. (1989) A multichannel FES system for the restoration of motor functions in high spinal cord injury patients: A respiration-controlled system for multijoint upper extremity, *IEEE Trans Biomed Eng*, Vol. 36; pp.754-760, ISSN0018-9294
- Jenkins, D.B. (2008) *Hollinshead's Functional Anatomy of the Limbs and Back* (9th ed.), WB Saunders, ISBN 978-1-4160-4980-7, Philadelphia
- Katz, R.; Penicaud, A. & Rossi, A. (1991) Reciprocal Ia inhibition between elbow flexors and extensors in the human. *J Physiol (Lond)*, Vol. 437; pp.269-286, ISSN 0022-3751
- Kobayashi, S.; Naito, A.; Hayashi, M.; Ogino, T.; Fujii, H. & Tonosaki, A. (2000) Inhibitory projections of muscle afferents from the brachioradialis to the flexor carpi radialis motoneurons in humans. *Acta Anat Nippon*, Vol. 76, p.130 (in Japanese), ISSN 0022-7722
- Lourenço, G.; Iglesias, C. & Marchand-Pauvert, V. (2007) Effects produced in human arm and forearm motoneurons after electrical stimulation of ulnar and median nerves at wrist level. *Exp Brain Res*, Vol. 178, pp.267-284, ISSN 0014-4819
- Marchand-Pauvert, V.; Nicolas, G. & Pierrot-Desilligny, E. (2000) Monosynaptic Ia projections from intrinsic hand muscles to forearm motoneurons in humans. *J Physiol (Lond)*, Vol. 525, pp.241-252, ISSN 0022-3751
- Miyasaka, T.; Sun, Y.-J.; Naito, A.; Morita, H.; Shindo, M.; Shimizu, Y. & Yanagisawa, N. (1995) Reciprocal inhibition between biceps brachii and brachioradialis in the human. In abstract, *4th IBRO World Congress of Neuroscience*; Rapid Communications, Oxford New York, p.334
- Miyasaka, T.; Sun, Y.-J.; Naito, A. & Shindo, M. (1996) Inhibition projections from the biceps brachii to the pronator teres motoneurons in the human. *Neurosci Res*, Suppl 20, S183, ISSN 0168-0102

- Miyasaka, T.; Naito, A.; Morita, H.; Sun, Y.-J.; Chishima, M. & Shindo, M. (1998) Inhibitory neural connection from the brachioradialis to the pronator teres in human. *Neurosci Res*, Suppl 22, S159, ISSN 0168-0102
- Miyasaka, T.; Naito, A.; Shindo, M.; Kobayashi, S.; Hayashi, M.; Shinozaki, K. & Chishima, M. (2007) Modulation of brachioradialis motoneuron excitabilities by group I fibers of the median nerve in humans. *Tohoku J Exp Med*, Vol. 212, pp.115-131, ISSN 0040-8727
- Naito, A.; Handa, Y.; Handa, T.; Ichie, M.; Hoshimiya, N. & Shimizu, Y. (1994) Study on the elbow movement produced by functional electrical stimulation (FES). *Tohoku J Exp Med*, Vol. 174, pp.343-349, ISSN 0040-8727
- Naito, A.; Shindo, M.; Miyasaka, T.; Sun, Y.-J. & Morita, H. (1996) Inhibitory projections from brachioradialis to biceps brachii in human. *Exp Brain Res*, Vol. 111, pp.483-486, ISSN 0014-4819
- Naito, A.; Shindo, M.; Miyasaka, T.; Sun, Y.-J.; Momoi, H. & Chishima, M. (1998a) Inhibitory projections from pronator teres to biceps brachii motoneurons in human. *Exp Brain Res*, Vol. 121, pp.99-102, ISSN 0014-4819
- Naito, A.; Sun, Y.-J.; Yajima, M.; Fukamachi, H. & Ushikoshi, K. (1998b) Electromyographic study of the elbow flexors and extensors in a motion of forearm pronation/supination while maintaining elbow flexion in humans. *Tohoku J Exp Med*, Vol. 186, pp.267-277, ISSN 0040-8727
- Naito, A.; Shinozaki, K.; Kobayashi, S.; Fujii, H.; Sato, T.; Miyasaka, T. & Shindo, M. (2001) Excitatory projections of muscle afferents between the brachioradialis and extensor carpi radialis in humans. *Neurosci Res*, Suppl 25, S87, ISSN 0168-0102
- Naito, A.; Yajima, M.; Chishima, M. & Sun, Y.-J. (2002) A motion of forearm supination with maintenance of elbow flexion produced by electrical stimulation to two elbow flexors in humans. *J Electromyogr Kinesiol*, Vol. 12, pp.259-265, ISSN 1050-6411
- Naito, A. (2003) Spinal mechanism for motor control: neural connections among muscles in the human upper limb. *Yamagata Med J*, Vol. 21, pp.155-169 (in Japanese) , ISSN 0288-030X
- Naito, A. (2004) Electrophysiological studies of muscles in the human upper limb: the biceps brachii. *Anat Sci Int*, Vol. 79, pp.11-20, ISSN 1447-6959
- Nakano, H.; Miyasaka, T.; Sagae, M.; Fujii, H.; Sato, T.; Suzuki, K.; Ogawa, K.; Shindo, M. & Naito, A. (2005) Facilitation from the pronator teres to extensor carpi radialis motoneurons in humans: Studies using a post-stimulus time-histogram technique. *Acta Anat Nippon*, 80 suppl, p.5, ISSN 0022-7722
- Nakano, H.; Miyasaka, T.; Sagae, M.; Fujii, H.; Sato, T.; Suzuki, K.; Shindo, M.; Ogino, T. & Naito, A. (2006) Facilitation between pronator teres and extensor carpi radialis: Studies with a PSTH method. *Clin Neurophysiol*, Vol. 117, S160, ISSN 1388-2457
- Ogawa, K.; Suzuki, K.; Fujii, H.; Sato, T.; Nakano, H.; Sagae, M.; Miyasaka, T.; Naito, A. & Watanabe, H. (2005) Facilitation from the thenar muscles to extensor carpi radialis in humans: A study using an electromyogram-averaging method with mechanical conditioning stimulation. *Yamagata Med J*, Vol. 23, pp.107-105 (in Japanese with English abstract and figure legends), ISSN 0288-030X
- Otaki, R.; Sato, T.; Naganuma, M.; Suzuki, K.; Narita, A.; Sato, A.; Miyasaka, T.; Fujii, H. & Naito, A. (2009) Effects of wrist flexion and extension on forearm supination force.

- Structure Function*, Vol. 8, pp.13-18 (in Japanese with English abstract and figure legends), ISSN 1347-7145
- Perotto, A.O. (1994) *Anatomical Guide for the Electromyographer: The Limb and Trunk* (3rd ed.), Charles C. Thomas, ISBN 0-398-05900-4, Springfield IL
- Pierrot-Deseilligny, E.; Morin, C.; Bergego, C. & Tankov, N. (1981) Pattern of group I fiber projections from ankle flexor and extensor muscles in man. *Exp Brain Res*, Vol. 42:, pp.337-350, ISSN 0014-4819
- Pierrot-Deseilligny, E. & Mazevet, D. (2000) The monosynaptic reflex: a tool to investigate motor control in humans. Interest and limits. *Neurophysiol Clin*, Vol. 30, pp.67-80, ISSN 0987-7053
- Riek, S.; Carson, R.C. & Wright, A. (2000) A new technique for the selective recording of extensor carpi radialis longus and brevis EMG. *J Electromyogr Kinesiol*, Vol. 10, pp.249-253, ISSN 1050-6411
- Rossi, A.; Decchi, B.; Zalaffi, A. & Mazzocchio, R. (1995) Group Ia non-reciprocal inhibition from wrist extensor to flexor motoneurons in humans. *Neurosci Lett*, Vol. 191, pp.205-207, ISSN 0304-3940
- Rothwell, J. (1994) *Control of Human Voluntary Movement* (2nd ed.) Chapman & Hall, ISBN 0-412-47700-9, London, pp149-181
- Sagae, M.; Suzuki, K.; Fujita, T.; Sotokawa, T.; Nakano, H.; Naganuma, M.; Narita, A.; Sato, T.; Fujii, H.; Ogino, T. & Naito, A. (2010) Strict actions of the human wrist extensors: A study with an electrical neuromuscular stimulation method. *J Electromyogr Kinesiol*, Vol. 20, pp.1178-1185, ISSN 1050-6411
- Sato, T.; Fujii, H.; Naito, A.; Tonosaki, A.; Kobayashi, S.; Shinozaki, K.; Miyasaka, T. & Shindo, M. (2002) Inhibition of muscle afferents from the brachioradialis to triceps brachii motoneurons in humans: Central pathway. *Acta Anat Nippon*, Vol. 77 Suppl, H511, ISSN 0022-7722
- Sato T, Suzuki K, Sotokawa T, Fujita T, Sagae M, Nakano H, Naganuma M, Fujii H, Kato K & Naito A (2007) Simultaneous recording system for digital video pictures and electric signals. *Structure Function*, Vol. 6, pp.3-8 (in Japanese with English abstract and figure legends), ISSN 1347-7145
- Sato, T.; Sato, T.; Konishi, Y.; Naganuma, M.; Suzuki, K.; Narita, A.; Fujii, H.; Hashizume, W. & Naito, A. (2011) Effects of wrist flexion and extension on forearm pronation force. *Structure Function*, Vol. 9, pp.59-63 (in Japanese with English abstract and figure legends), ISSN 1347-7145
- Shinozaki, K.; Naito, A.; Kobayashi, S.; Miyasaka, T.; Shindo, M. & Tonosaki, A. (2001) Pathways of facilitatory projections between the brachioradialis and extensor carpi radialis in humans. *Acta Anat Nippon*, Vol. 76, p.130 (in Japanese), ISSN 0022-7722
- Standring, S.; Ellis, H.; Healy, C.; Johnson, D. & Williams, A. (2005) *Gray's Anatomy* (39th ed.) Elsevier, Churchill Livingstone, ISBN 0-443-07168-3, Edinburgh, pp.879-880
- Suzuki, K.; Nakano, H.; Sato, T.; Fujii, H.; Ogawa, K.; Watanabe, H. & Naito, A. (2005) Facilitation from the median nerve innervating hand muscles to extensor carpi radialis in humans: A study using an electromyogram-averaging method. *Yamagata Med J*, Vol. 23, pp.59-68 (in Japanese with English abstract and figure legends), ISSN 0288-030X
- Suzuki, K.; Fujita, T.; Sotokawa, T.; Naganuma, M.; Sato, T.; Fujii, H.; Nakano, H.; Narita, A.; Miyasaka, T.; Shindo, M. & Naito, A. (2007) Facilitation from hand muscles

- innervated by the ulnar nerve to extensor carpi radialis in humans: A study using an electromyogram-averaging method. *Jpn J Clin Neurophysiol*, Vol. 35, p.449-450 (in Japanese), ISSN 1345-7101
- Tanaka, R. (1989) Spinal mechanisms for human motor control. In: *Annual Review of Neuroscience*, edited by M. Ito & H. Narabayashi, Igaku-Shoin, ISBN4-260-17303-0, Tokyo, pp. 61-91 (in Japanese)
- Wargon. I.; Lamy, J.C.; Baret, M.; Ghanim, Z.; Aymard, C.; Penicaud, A. & Katz, R. (2006) The disynaptic group I inhibition between wrist flexor and extensor muscle revisited in humans. *Exp Brain Res*, Vol. 168, pp.203-217, ISSN 0014-4819
- Yoshida, Y. (1994) Anatomical studies on the extensor carpi radialis longus and brevis muscles in Japanese. *Okajima's Folia Anat Jpn*, Vol. 71, pp.123-136, ISSN 0030-154X

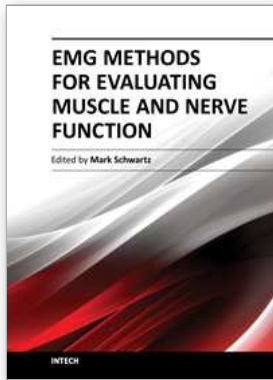

## **EMG Methods for Evaluating Muscle and Nerve Function**

Edited by Mr. Mark Schwartz

ISBN 978-953-307-793-2

Hard cover, 532 pages

**Publisher** InTech

**Published online** 11, January, 2012

**Published in print edition** January, 2012

This first of two volumes on EMG (Electromyography) covers a wide range of subjects, from Principles and Methods, Signal Processing, Diagnostics, Evoked Potentials, to EMG in combination with other technologies and New Frontiers in Research and Technology. The authors vary in their approach to their subjects, from reviews of the field, to experimental studies with exciting new findings. The authors review the literature related to the use of surface electromyography (SEMG) parameters for measuring muscle function and fatigue to the limitations of different analysis and processing techniques. The final section on new frontiers in research and technology describes new applications where electromyography is employed as a means for humans to control electromechanical systems, water surface electromyography, scanning electromyography, EMG measures in orthodontic appliances, and in the ophthalmological field. These original approaches to the use of EMG measurement provide a bridge to the second volume on clinical applications of EMG.

### **How to reference**

In order to correctly reference this scholarly work, feel free to copy and paste the following:

Akira Naito, Hiromi Fujii, Toshiaki Sato, Katsuhiko Suzuki and Haruki Nakano (2012). Functional Significance of Facilitation Between the Pronator Teres and Extensor Carpi Radialis in Humans: Studies with Electromyography and Electrical Neuromuscular Stimulation, EMG Methods for Evaluating Muscle and Nerve Function, Mr. Mark Schwartz (Ed.), ISBN: 978-953-307-793-2, InTech, Available from: <http://www.intechopen.com/books/emg-methods-for-evaluating-muscle-and-nerve-function/functional-significance-of-facilitation-between-the-pronator-teres-and-extensor-carpi-radialis-in-hu>

**INTECH**  
open science | open minds

### **InTech Europe**

University Campus STeP Ri  
Slavka Krautzeka 83/A  
51000 Rijeka, Croatia  
Phone: +385 (51) 770 447  
Fax: +385 (51) 686 166  
[www.intechopen.com](http://www.intechopen.com)

### **InTech China**

Unit 405, Office Block, Hotel Equatorial Shanghai  
No.65, Yan An Road (West), Shanghai, 200040, China  
中国上海市延安西路65号上海国际贵都大饭店办公楼405单元  
Phone: +86-21-62489820  
Fax: +86-21-62489821

© 2012 The Author(s). Licensee IntechOpen. This is an open access article distributed under the terms of the [Creative Commons Attribution 3.0 License](#), which permits unrestricted use, distribution, and reproduction in any medium, provided the original work is properly cited.