

Application of the Genetic Algorithms for Identifying the Electrical Parameters of PV Solar Generators

Anis Sellami¹ and Mongi Bouaïcha²

¹Laboratoire C3S, Ecole Supérieure des Sciences et Techniques de Tunis,

²Laboratoire de Photovoltaïque, Centre de Recherches et des Technologies de l'Energie, Technopole de Borj-Cédria, Tunisia

1. Introduction

The determination of model parameters plays an important role in solar cell design and fabrication, especially if these parameters are well correlated to known physical phenomena. A detailed knowledge of the cell parameters can be an important way for the control of the solar cell manufacturing process, and may be a mean of pinpointing causes of degradation of the performances of panels and photovoltaic systems being produced. For this reason, the model parameters identification provides a powerful tool in the optimization of solar cell performance.

The algorithms for determining model parameters in solar cells, are of two types: those that make use of selected parts of the characteristic (Chan et al., 1987; Charles et al., 1981; Charles et al., 1985; Dufo-Lopez and Bernal-Agustin, 2005; Enrique et al., 2007) and those that employ the whole characteristic (Haupt and Haupt, 1998; Bahgat et al., 2004; Easwarakhanthan et al., 1986). The first group of algorithms involves the solution of five equations derived from considering select points of an current-voltage (I-V) characteristic, e.g. the open-circuit and short-circuit coordinates, the maximum power points and the slopes at strategic portions of the characteristic for different level of illumination and temperature. This method is often much faster and simpler in comparison to curve fitting. However, the disadvantage of this approach is that only selected parts of the characteristic are used to determine the cell parameters. The curve fitting methods offer the advantage of taking all the experimental data in consideration. Conversely it has the disadvantage of artificial solutions. The nonlinear fitting procedure is based on the minimisation of a not convex criterion, and using traditional deterministic optimization algorithms leads to local minima solutions. To overcome this problem, the nonlinear least square minimization technique can be computed with global search approaches such Genetic Algorithms (GAs) (Haupt and Haupt, 1998; Sellami et al., 2007; Zagrouba et al., 2010) strategy, increasing the probability of obtaining the best minimum value of the cost function in very reasonable time.

In this chapter, we propose a numerical technique based on GAs to identify the electrical parameters of photovoltaic (PV) solar cells, modules and arrays. These parameters are, respectively, the photocurrent (I_{ph}), the saturation current (I_s), the series resistance (R_s), the

shunt resistance (R_{sh}) and the ideality factor (n). The manipulated data are provided from experimental I-V acquisition process. The one diode type approach is used to model the AM1.5 I-V characteristic of the solar cell. To extract electrical parameters, the approach is formulated as a non convex optimization problem. The GAs approach was used as a numerical technique in order to overcome problems involved in the local minima in the case of non convex optimization criteria.

This chapter is organized as follows: Firstly, we present the classical one-diode equivalent circuit and discuss its validity to model solar modules and arrays. Then, we expose the limitations of the classical optimization algorithms for parameters extraction. Next, we describe the detailed steps to be followed in the application of GAs for determining solar PV generators parameters. Finally, we show the procedure of extracting the coordinates (V_m, I_m) of the maximum power point (MPP) from the identified parameters.

2. The one diode model

The I-V characteristic of a solar cell under illumination can be derived from the Schottky diffusion model in a PN junction. In Fig. 1, we give the scheme of the equivalent electrical circuit of a solar cell under illumination for both cases; the double diode model and the one diode model.

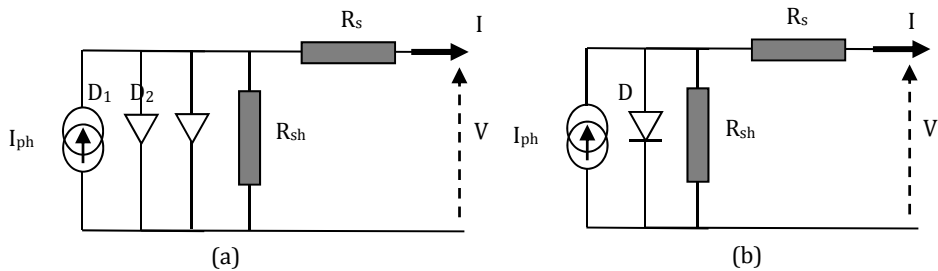

Fig. 1. Scheme of the equivalent electrical circuit of an illuminated solar cell: (a) the double diode model, and (b) the one diode model.

A rigorous and complete expression of the I-V characteristic of an illuminated solar cell that describes the complete transport phenomena is given by: (Sze, 1982)

$$I = I_{ph} - I_{s1} \left[e^{\frac{V+R_s I}{V_{th}}} - 1 \right] - I_{s2} \left[e^{\frac{V+R_s I}{2V_{th}}} - 1 \right] - \frac{V+R_s I}{R_{sh}} \quad (1)$$

Where I_{ph} is the photocurrent, I_{s1} and I_{s2} are the saturation currents of diodes D_1 and D_2 , respectively. R_s is the series resistance, R_{sh} is the shunt resistance and V_{th} is the thermal voltage. However, it is well established that value of I_{s2} is generally 10^{-6} times lesser than that one of I_{s1} . For this reason, it is well suitable to restrict ourselves to the one diode model. In addition, despite the fact that the double diode model can take into account all the conduction modes, which is likely for physical interpretation, it may generate many difficulties. Hence, in this case, the accuracy of the fitting related to the value of the ending cost of the objective function, which corresponds to the admitted absolute minimum can be improved (Ketter et al., 1975). However, the physical meaning of the solution is lost, since

the number of parameters is augmented by 2 for the second diode. Consequently, the unicity of the solution is affected. However, precise experiments taking into account different physical phenomena contributing to the electronic transport are suitable to identify all the conduction modes. The single one diode model used here is rather simple, efficient and sufficiently accurate for process optimization and system design tasks. In photovoltaic, the output power of a solar module and a solar array is generally dependant of the electrical characteristics of the poor cell in the module, and the electrical characteristics of the poor module in an array. To skip this difficulty, electrical parameters of all cells forming a photovoltaic module should be very close each one to the other. For a photovoltaic array, all solar modules forming it should also have similar electrical characteristics. Consequently, the one diode model can also be applied to fit solar modules and arrays if we ensure that the cell to cell and the module to module variations are not important (Easwarakhanthan et al., 1986). It should be noted, however, that the parameters determined by the one diode model will lose somewhat their physical meaning in the case of solar modules and arrays. Consequently, the precision of each fitting approach will be certainly better in the case of solar cells than that of solar modules, which itself, should be more accurate than that of solar arrays.

Under these assumptions, results could be very acceptable with a good accuracy, and in replacement of expression (1), we will use the I-V relation given by expression (2), where n is the ideality factor. (Charles et al., 1985)

$$I = I_{ph} - I_s \left[e^{\frac{V+R_s I}{nV_{th}}} - 1 \right] - \frac{V + R_s I}{R_{sh}} \tag{2}$$

Using expression (2) and the GAs, we can determine values of the electrical parameters R_s , $G_{sh}=1/R_{sh}$, I_{ph} , n and I_s .

3. Classical optimization algorithms

The error criterion which used in classical curve fitting is based on the sum of the squared distances separating experimental I_i and predicted data $I(V_i, \theta)$:

$$S(\theta) = \sum_{i=1}^m [I_i - I(V_i, \theta)]^2 \tag{3}$$

Where $\theta = (I_{ph}, I_s, n, R_s, G_{sh})$, I_i and V_i are respectively the measured current and voltage at the i^{th} point among m data points.

The equation (3) is implicit in I and one way of simplifying the computation of $I(V_i, \theta)$ is to substitute I_i and V_i in equation (3). Hence, we obtain the following equation:

$$I(V_i, \theta) = I_{ph} - I_s \left[\text{Exp}\left(\frac{(V_i + R_s I_i)}{nV_{th}}\right) - 1 \right] - G_{sh} (V_i + R_s I_i) \tag{4}$$

The equation (4) is nonlinear. Hence, the resulting set of normal equations $F(\theta)=0$, derived from multivariate calculus will be non linear and no exact solution can be found. To obtain

an approximation of the exact solution, we use Newton's method. The Newton functional iteration procedure evolves from:

$$[\theta_k] = [\theta_{k-1}] - [J(\theta_{k-1})]^{-1} [F(\theta_{k-1})] \quad (5)$$

Where $J[\theta]$ is the Jacobean matrix

Although, using Newton's Method, the initializing step of the five parameters plays a prominent part in the identification and determines drastically the convergence. There is a net difficulty in initializing the fitting parameters, which can be overcome by performing a procedure based on a reduced non-linear least-squares technique in which only two parameters have to be initialized. The electrical parameters are grouped in two classes: the series resistance R_s and the diode quality factor n for the first one and the shunt resistance R_{sh} , the photocurrent I_{ph} and the saturation current I_0 for the second one.

The model is highly non-linear for the first class, if n and R_s were fixed, the model would have a linear behaviour in regard to the second class. So that these parameters are estimated by linear regression (Chan et al., 1987). Keeping these three parameters constant, the model will be non-linear in regard to the first class of parameters. The objective function $S(\theta)$ will be minimized with respect to n and R_s . The two non-linear equations resulting from multivariate calculus are solved also by Newton's method, the iterations for n and R_s are continued till the relative accuracy for each of them becomes less than 0,1%. The steps are then repeated with the new determined values of n and R_s , till the relative difference between two consecutive values of S computed soon after each linear regression, becomes smaller than a relative error which depends on the accuracy of the measured data.

The intention of the initializing procedure is to reduce from five to two the number of parameters that have to be initialized; a result of this first step is to have five starting values of the parameters within the domain of convergence. The feature of this set of values obtained from the first step is:

- The two parameters responsible on the non linearity are almost near the final result.
- The three parameters of the second class which are responsible on the supra linearity are sufficiently accurate.

To overcome the undesired oscillations and an eventual overflow which results from the Newton step choice, the algorithm uses a step adjustment procedure at each iteration. The modified Newton functional iteration procedure evolves from:

$$[\theta_k] = [\theta_{k-1}] - \lambda [J(\theta_{k-1})]^{-1} [F(\theta_{k-1})] \quad (6)$$

The Newton steps are continued until the successively computed parameters are found to change by less than 0.0001%. At this end, Dichotomies method is used to solve the implicit equation (3).

This algorithm is tested for a number of samples of solar cells and for many configurations of initial values, it has been demonstrated that it converges in few seconds. The number of bugs resulting from overflows is scarce. Dead lock events do not exceed 3% for all the cells that are performed. The results of the fitted curve and experimental data for a 57 mm diameter silicon solar cell are presented in Fig. 2, Fig. 3 and Fig. 4.

The results show that for Fig. 4, the algorithm finds the absolute minimum with the desired accuracy (less than 0.3%). However, the initialized parameters in Fig. 2 and Fig. 3 allow the algorithm to converge to local minimums.

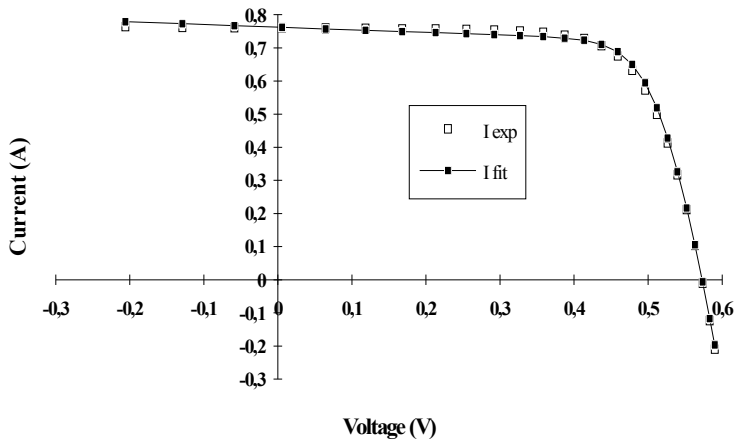

Fig. 2. Comparison between the experimental I-V characteristic and the fitted curve for a 57 mm diameter solar cell. The initial value of n and R_s are: $n=1$; $R_s=0\Omega$

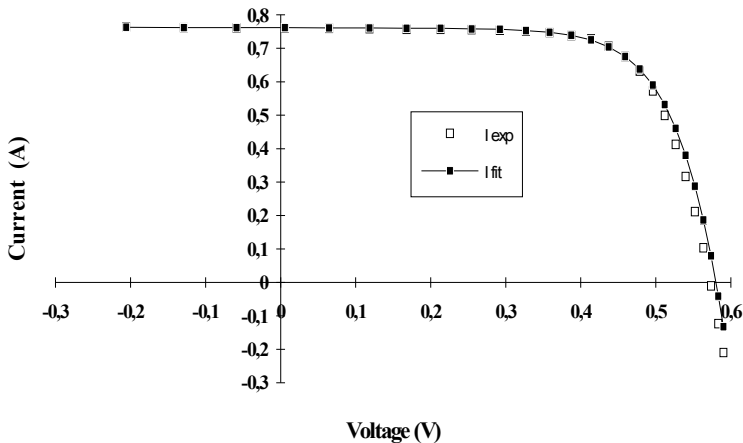

Fig. 3. Comparison between the experimental I-V characteristic and the fitted curve for a 57 mm diameter solar cell. The initial value of n and R_s are: $n=2$; $R_s=0\Omega$

In order to analyse the effect of the initialized parameters n and R_s on the minimization of the error criterion, we have fixed one of them and we have varied the other.

Fig. 5 depicts the evolution of the objective function in regard to the initial value of N parameters (N varies from 1 up to 2). The initial value of R_s is fixed, and the minima are represented by dots joined just more clearness. We remark that the initial value of N parameters decides on the type of minimum whether it is absolute (case $N_{init}=1.5$) or relative (the other cases). We note that the search trajectory is a set of parabolic arcs confirming the fact that:

- the minimum is the absolute and hence it represents the real solution, and

- the objective function is almost quadratic near the absolute minimum.

Fig. 6 gives the evolution of the objective function with the initial value of R_s (the initial value of R_s varies from 10^{-6} to 0.1Ω); the initial value of n is fixed. We deduce that the starting value of R_s has, practically no influence on the minimum in comparison with the effect of the initial

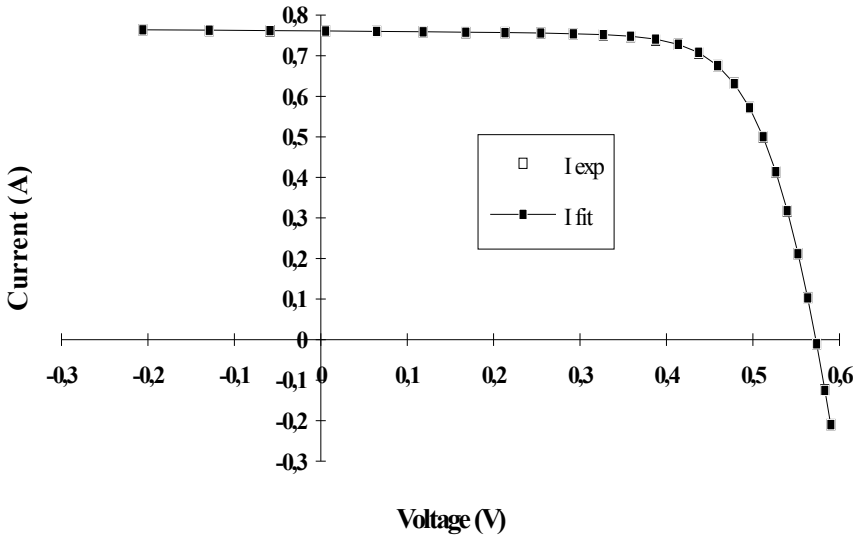

Fig. 4. Comparison between the experimental I-V characteristic and the fitted curve for a 57 mm diameter solar cell. The initial value of n and R_s are: $n=1,5$; $R_s=0,001\Omega$

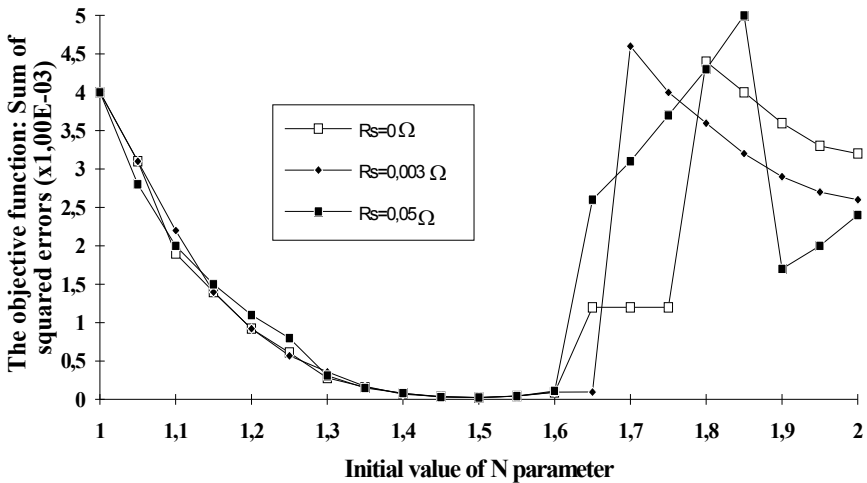

Fig. 5. Search path of the absolute minimum in R_s plans.

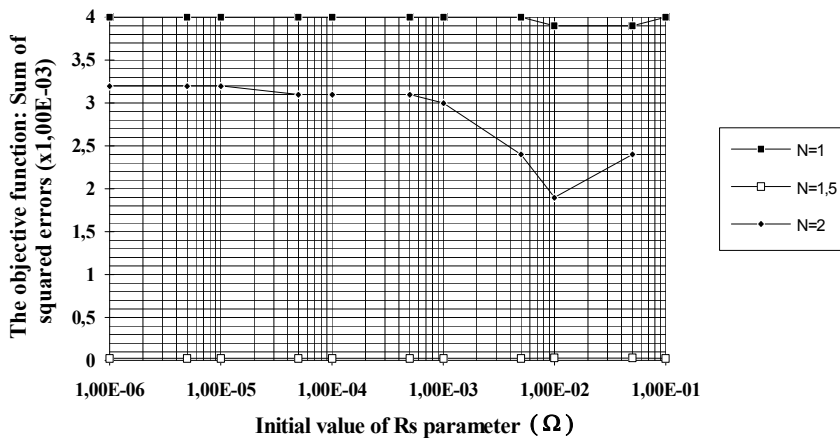

Fig. 6. Search path of the absolute minimum in n plans.

value of n parameter. Therefore, the initial value of R_s is tacked to be arbitrary within an interval witch take into consideration the physical proprieties of this parameter.

For each combination of (R_s initial, n initial), the algorithm converges to a minimum which can be relative or absolute. We stress on the fact that theoretically there is no way to predict the nature of the minimum (absolute or relative) for non linear models when we use Newton method. When the initial value of the n parameter is sampled linearly in the interval of its natural variation from 1 to 2 (Fig. 5), we have excluded, in such manner, the influence of the initial conditions. We obtain a set of minima; we deduce the absolute minimum which is the lowest and the real solution.

4. Application of the genetic algorithms

To numerically carry out the electrical parameters of the solar generators (cell and module), from the measured I-V curves, we fit the theoretical expression given in equation (2) to the experimental one. The fitting procedure is based on the use of the genetic algorithms (GAs). The error criterion in the nonlinear fitting procedure is based on the sum of the squared difference between the theoretical and experimental current values. As a consequence, the cost function to be minimized is given by (Easwarakhanthan et al., 1986; Phang et al., 1986):

$$\chi = \sum_{i=1}^m [I_i^{\text{exp}} - I(V_i, \theta)]^2 \tag{7}$$

Where I_i^{exp} is the measured current at the V_i bias, $\theta = (I_{ph}, I_s, R_s, G_{sh}, n)$ is the set of parameters to carry out, m the number of considered data points and $I(V_i, \theta)$ is the predicted current.

Eq. (2) is implicit in I; one way of simplifying the computation of $I(V_i, \theta)$ is to substitute I_i and V_i in Eq. (2). Hence, we obtain Eq. (8).

$$I(V_i, \theta) = I_{ph} - I_s \left[\exp \left(\frac{q(V_i + R_s I)}{nKT} \right) - 1 \right] - G_{sh} (V_i + R_s I) \tag{8}$$

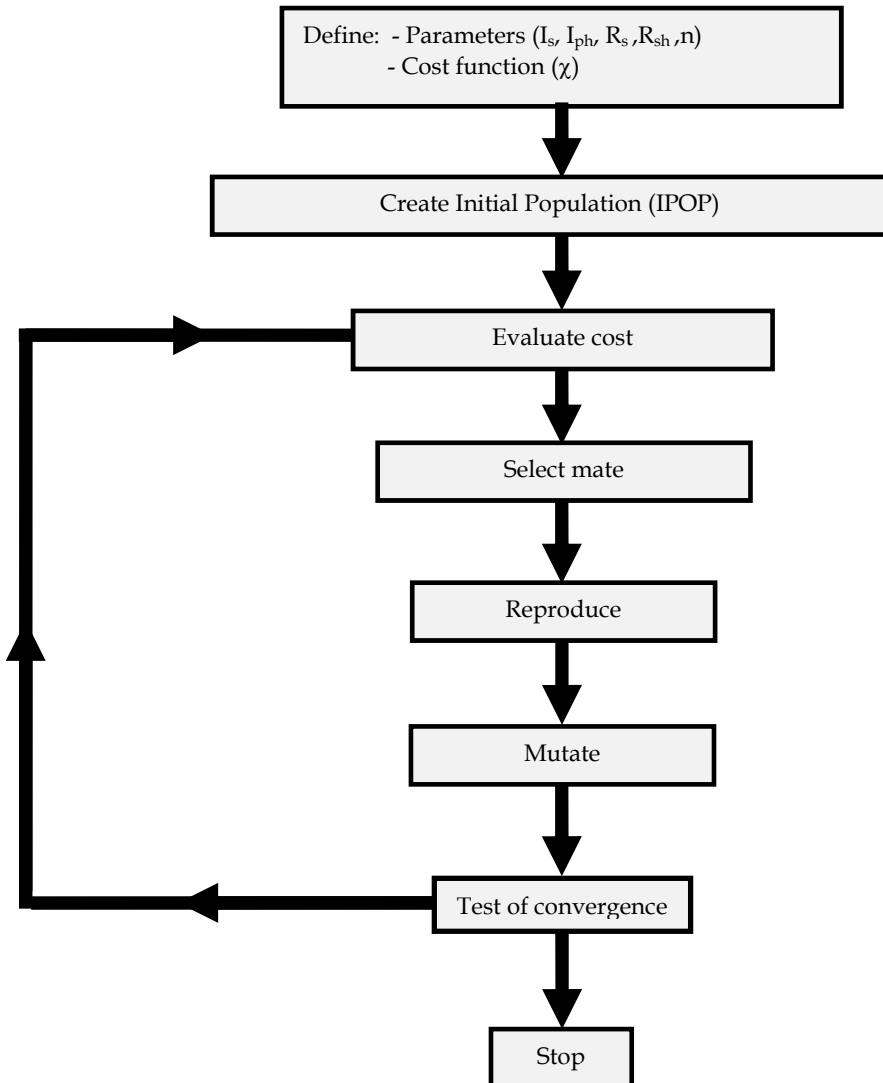

Fig. 7. Flow chart of the genetic algorithms.

Where:

N_{ipop} is the initial number of chromosomes in IPOP,

N_{par} is the number of parameters in the chromosome ($N_{par} = 5$ in our case),

l_o and h_i are respectively the lowest and the highest values of parameters I_s , I_{ph} , R_s , R_{sh} and n .

In Fig. 7, we give the flow chart of the GAs. The chromosome here is the vector θ containing the five parameters I_{ph} , I_s , R_s , G_{sh} , and n . The initial population (IPOP) of chromosomes is a matrix given by Eq. (9): (Easwarakhanthan et al., 1986)

$$IPOP = (h_i - l_o).random[N_{ipop}, N_{par}] + l_o \quad (9)$$

The very common operators used in GAs are selection, reproduction and mutation (Haupt and Haupt, 1998; Sellami et al., 2007; Zagrouba et al., 2010), which are described as follows:

1. *Selection*: This procedure is applied to select chromosomes that participate in the reproduction process to give birth to the next generation. Only the best chromosomes are retained for the next generation of the algorithm, while the bad ones are discarded. There are several methods of this process, including the elitist model, the ranking model, the roulette wheel procedure, etc.
2. *Reproduction/pairing*: This procedure takes two selected chromosomes from a current generation (parents) and crosses them to obtain two individuals for the new generation (offspring's). There are several types of crossing, but the simplest methods choose arbitrary one or more points (parameters) in the chromosome of each parent to mark as crossover points. Then the parameters between these points are merely swapped between the two parents.

In our case, each parent is represented by a chromosome containing five parameters. The pairing is performed by crossing one, two, three, four and five parameters between the two parents, leading to obtain from these two parents a new generation of 2^5 individuals (chromosomes).

3. *Mutation*: It consists of introducing changes in some genes (parameters) of a chromosome in a population. This procedure is performed by GAs to explore new solutions. Random mutations alter a small percentage of the population (mutation rate) except for the best chromosomes. A mutation rate between 1% and 20% often works well. If the mutation rate is above 20%, too many good parameters can be mutated, and then the algorithm stalls. In our case, mutation was applied to all parameters of 4% of chromosomes number. Note that the new value of each parameter should be in the $[l_o, h_i]$ corresponding interval. Consequently, after pairing, mutated parameters are engaged to ensure that the parameters space is explored in new regions.

The used GA program is a homemade. We developed it on Matlab environment, for both PV cell, module and array. For flexibility, we choose to develop this program instead of using Genetic Algorithms and Direct Search Toolbox of Matlab.

4.1 Identification of the electrical parameters of the solar cell

Current-Voltage characteristic under AM1.5 illumination was performed using the cell tester CT 801 from Pasan (Pasan, 2004). This cell tester includes in the same compact architecture a single-flash xenon light source, an automatic sliding contact frame, a test chuck with interchangeable plates to fit any cell configuration, a calibrated reference cell, and a Panel-PC type computer. To become a fully featured cell testing unit, it needs to be connected to an external electronic load and flash generator, itself included in a 19" 6U rack. Its single-flash technology gives a negligible heating of the cell, in the tenths of a degree range, much lower than continuous-light testers, so an accurate I-V curve determination can be achieved (Pasan, 2004). In Fig. 8, we give the plot of the I-V curve of a multicrystalline silicon solar cell having a surface area of 4 cm^2 .

To determine the cell parameters, we use equation (2) and the I-V curve of Fig. 8. Obtained results are compared to those obtained by the Pasan cell tester software version V3.0.

In general, the time-convergence of the algorithm is influenced by the choice of the IPOP. If coordinates of the absolute minimum of the cost function in the parameter's space are unknown, initial invidious (IPOP) were generated randomly. The latter were chosen



Fig. 8. Experimental I-V curve of the solar cell performed with the Pasan machine.

uniformly between the highest and the lowest value of each parameter. In this work, the first generation was started with 14^5 (537824) chromosomes as the initial population (IPOP), where 5 is the number of parameters to be identified. Each parameter in a chromosome has a lowest (l_0) and a highest (h_i) value. Since the interval between l_0 and h_i contains an infinite number of values, we started in the simulation with different values such as 200, 100, 50, 25, 15, 10 and 5. We remark that simulation results are similar for all values 200, 100, 50, 25, 15 and 14. For values less than 14, the algorithm leads to a relatively high value of the cost function.

After determining the cost function for each chromosome, we apply a selection in IPOP (Select mate): only a family of good chromosomes that corresponds to good values of the cost was kept for the pairing (reproduce) and the others (bad) were killed. To ensure that the parameters space is suitably explored, a mutation of 4% in the chromosomes was operated (mutate). At the end of the algorithm, the convergence was tested. If the result (last value of χ) does not give satisfaction compared to a predefined cost minimum ($\chi=0.000270$ A²), all below steps are repeated in the second generation and so on. The fitting result is plot in Fig. 9. As we can see, theoretical curve fits very well experimental results.

In Fig. 10, we plot the mean and the minimum values of the cost function with respect to the generation number. One can notice that beyond the third generation, the cost function becomes stable in a relative good minimum. The minimum value of the cost function was found to be equal to 0.000256 A² and was reached after five generations. According to this relatively good value, one can assume that the GAs are very suitable for the estimation of the electrical parameters via the fitting method. In table 1, we compare the electrical parameters resulting from the use of the GAs-based fitting procedure, with those given by the Pasan cell tester software. Hence, the minimization problem is of five parameters (I_{ph} , I_s , R_s , R_{sh} , n), which is a hard problem in fitting procedures. As presented in table 1, the Pasan software gives only estimations of three parameters (I_{ph} , R_s , R_{sh}) from the five unknown ones. The saturation current I_s and the ideality factor n are not performed. In contrast, using the GAs method, we can estimate values of I_s and n in addition to the other three parameters (I_{ph} , R_s , R_{sh}). Obtained values' using the Pasan software and GAs method are identical for I_{ph} and

differs of 1% for R_{sh} . However, value of R_s obtained with the Pasan software is 7.5 times that one obtained with GAs. Regarding the good fitting result in Fig. 9, and taking into account that the R_s effect on the I-V curve is in general observed for voltages near the V_{oc} value, one can argue that the output value of R_s obtained with GAs is reasonable, but no conclusion can be done on the R_s value given by the Pasan software since no fitting is presented.

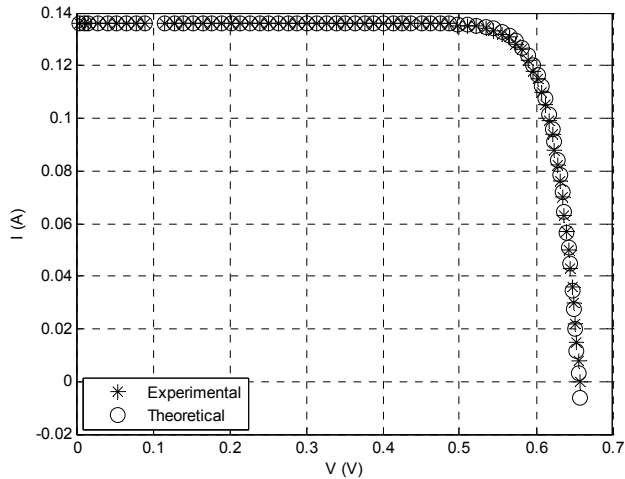

Fig. 9. Adjustment of the theoretical I-V curve of the solar cell's to the experimental one using GAs method.

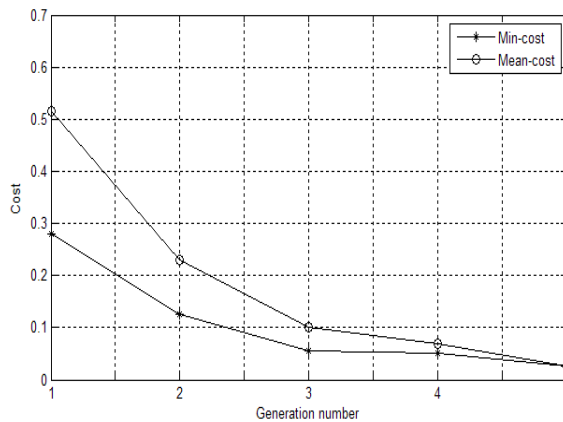

Fig. 10. Mean and minimum values of the χ function versus generation number of the solar cell.

Electrical parameters	Pasan CT 801	Genetic Algorithms
I_s (A)	Not performed	$1.2170 \cdot 10^{-2}$
I_{ph} (A)	0.1360	0.1360
R_s (Ω)	0.2790	0.0363
R_{sh} (Ω)	99999	99050
n	Not performed	1.0196

Table 1. Comparison between the electrical parameters determined using GAs and those given by the Pasan CT 801 software in the case of the used solar cell.

4.2 Determination of the PV module parameters

For the module characterization, we use a homemade solar module tester. The system takes advantage of the quick response time of PV devices by illuminating and characterising the samples within a few milliseconds. The tester measures the complete I-V curve of the PV module by using a capacitor load (Sellami et al., 1998). In the meantime, it measures the illumination level, the temperature, the voltage and its corresponding current in order to minimize the quantification errors coming from ADC and DAC conversion. Data are then transferred to the computer that calculates the efficiency, the short circuit current, the open circuit voltage and the fill factor. The bloc diagram of the PV module tester is given in Fig. 11. We used a commercial 50 Wp PV module manufactured by ANIT-Italy. Testing was performed at 44°C and 873 W/m² illuminations.

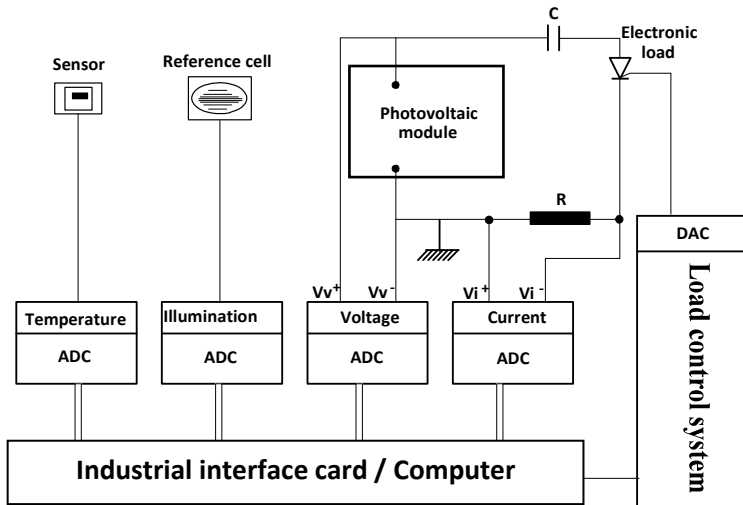

Fig. 11. Block diagram of the PV module tester.

The adjustment of the theoretical I-V curve of the PV module to the experimental one using GAs, and the mean and the minimum values of the cost function χ versus generation number are given in Fig. 12 and 13, respectively. In this simulation (PV module), we choose 12^5 chromosomes as IPOP and the predefined cost minimum is $\chi=0.0700 A^2$.

In the case of the used PV module, the GAs-based fitting procedure of the theoretical I-V curve to the experimental one (achieved using the PV module tester shown in Fig. 11) gives a minimum value around 0.0676 A² and was reached after only seven generations. The results of this minimization are shown in Table 2.

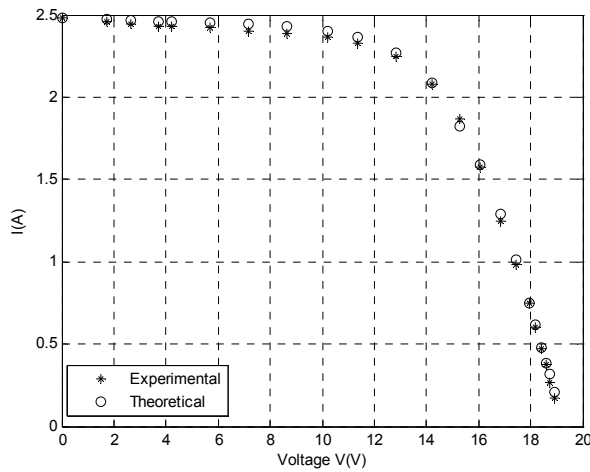

Fig. 12. Adjustment of the theoretical I-V curve of the PV solar module to the experimental one, using Gas.

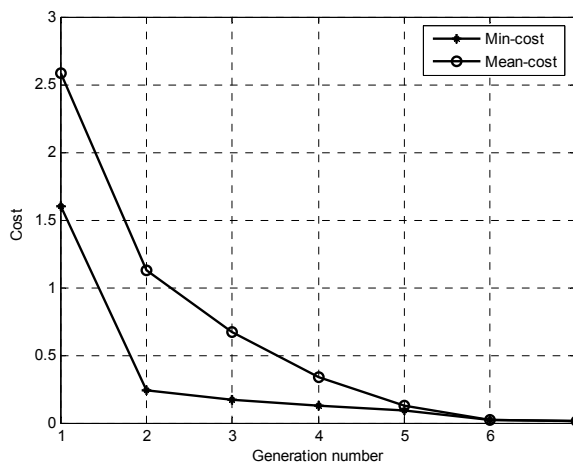

Fig. 13. The mean and the minimum values of the standard deviation χ versus generation number (case of PV solar modules).

Electrical parameters	Values (GAs)
I_s (A)	$8.1511 \cdot 10^{-6}$
I_{ph} (A)	2.4901
R_s (Ω)	0.9539
R_{sh} (Ω)	196.4081
n	60.4182

Table 2. Electrical parameters of the PV module obtained with GAs.

4.3 Determination of the Maximum Power Point

In order to extract the maximum available power from a PV cell, it is necessary to use it (the cell) at its maximum power point (MPP). Several MPP methods, such as perturbation, fuzzy control, power-voltage differentiation and on-line method have been reported (Dufo-Lopez and Bernal-Agustin, 2005; Bahgat et al., 2004; Yu et al., 2004). These control methods have drawbacks in stability and response time in the case when solar illumination changes abruptly. A direct MPP method using PV model parameters was introduced in (Yu et al., 2004). However, the validity of obtained result depends on the accuracy of the model parameters; i.e. the criterion for parameters extraction is not convex, and the traditional deterministic optimization algorithm used in (Yu et al., 2004) leads to local minima solutions. Indeed, in our case, we use the GAs, which belongs to heuristic solutions that represent a trade-off between solution quality and time. The GAs have a stochastic search procedure in nature, they usually outperform gradient based techniques in getting close to the global minima and hence avoid being trapped in local ones.

A derivative of the output power P with respect to the output voltage V is equal to zero at MPP.

$$\frac{dP}{dV} = I - V \left[\frac{\frac{q}{nkT} \left(I_{ph} + I_s - I - \frac{V + R_s I}{R_{sh}} \right) + \frac{1}{R_{sh}}}{1 + \frac{qR_s}{nkT} \left(I_{ph} + I_s - I - \frac{V + R_s I}{R_{sh}} \right) + \frac{R_s}{R_{sh}}} \right] = 0 \quad (10)$$

If the parameters of the equivalent circuit model are given, MPP is obtained by solving Eq. (10) using standard numerical non-linear method. This can be easily achieved with the optimisation Toolbox of MATLAB software.

In table 3, we give the current and voltage values corresponding to the Maximum Power Points (MPP) obtained using Eq. (10) and the electrical parameters given in tables 1 and 2 identified by the GAs. The output results in the case of the solar cell are compared to those provided by the Pasan software. In the case of the cell (table 3), one can notice that our GAs simulations results differ at least by 5.3% from those given by the Pasan software. In general, the well used procedure to estimate the MPP in cell and module testers is based on the selection of the maximum power from an experimental set of current-voltage multiplication. The accuracy of this statistical approach depends on the precision of the experimental data, which should surround the real value of the MPP. However, our approach presents two advantages; first, it is based on Eq. (10), which is free of these experimental constrains. Secondly, Eq. (10) itself, uses the identified electrical parameters extracted by the GAs that belong to a sophisticated global search method.

Obtained results in the case of the PV cell using the Pasan software and the GAs are nearly identical. However, in the case of the PV module, our homemade system is able to measure I-V characteristics, but it is not equipped with sophisticated software to give the electrical characteristics of the module. Consequently, the measured I-V curve of the module is analysed only with the GAs method, and no comparison is performed as shown in table 3. The credibility of obtained results with the PV module is extrapolated from that one of the PV solar cell, where obtained results with the GAs technique are compared to those obtained using a professional machine (Pasan CT 801).

	I_{opt} (A)	U_{opt} (V)	MPP (W)
Cell (using GAs)	0.137	0.571	0.078
Cell (using Pasan software V 3.0)	0.131	0.565	0.074
Module (using GAs)	2.120	14.200	30.104

Table 3. MPP's coordinates of the solar cell and the solar module and their corresponding powers.

5. Conclusion

This chapter has studied the extraction of solar generators' (cell and module) parameters from the I-V characteristics under illumination. The main problem that has been addressed is the accuracy of the determined parameters with curve fitting by using optimisation algorithms.

In this work, we proposed the genetic algorithms to extract PV solar cells electrical parameters. The determination of these parameters using experimental data was formulated in the form of a non convex optimization problem. The curve fitting by the Newton algorithm, conducts to less satisfactory results, which depend on the initial conditions leading to local minima solutions. We thus used the genetic algorithms (GAs) as an optimization tool in order to increase the probability to reach the global minima solutions.

The algorithm for the identification of solar modules electrical parameters can be extended to multi-diode model. Furthermore, we can use a minimisation criterion based on the area difference between the experimental and theoretical characteristics. Moreover, hybrid algorithms which combine heuristic solutions as GAs and PSO (Particle Swarm Optimisation) with deterministic methods can be a powerful tool in the future.

6. References

- Bahgat, A. B. G., Helwa, N.H., Ahamd, G.E., El Shenawy, E.T., 2004. Estimation of the maximum power and normal operating power of a photovoltaic module by neural networks. *Ren. Energy* 29 (3), 443-457.
- Chan, Daniel S. H., Phang, Jacob C. H., 1987, Analytical Methods for the extraction of Solar-Cell Single- and Double-Diode Model Parameters from I-V Characteristics, *IEEE Transactions on Electron Devices*, Vol. ED-34, N°2, p. 286-293.
- Charles, J. P., Abdelkrim, M., Muoy, Y. H., Mialhe, P., 1981. A practical method of analysis of the current voltage characteristics of solar cells. *Solar cells*, 4, p.169-178.

- Charles, J. P., Ismail, M.A., Bordure, G., 1985, A critical study of the effectiveness of the single and double exponential models for I-V characterization of solar cells. *Solid-State Electronics*, Vol. 28, N°8, p. 807-820.
- Dufo-Lopez, Rodolfo, Bernal-Agustin, José L., 2005, Design and control strategies of PV-Diesel systems using genetic algorithms. *Sol. Energy*, 79, 33–46.
- Easwarakhanthan, T., Bottin, J., Bouhouch, I., Boutrif, C., 1986. Non linear minimization algorithm for determining the solar cell parameters with microcomputers. *Int. J. Solar Energy*, Vol.4, p.1-12.
- Enrique, J.M., Durán, E., Sidrach-de-Cardona, M., Andújar, J.M., 2007. Theoretical assessment of the maximum power point tracking efficiency of photovoltaic facilities with different converter topologies. *Solar Energy*, Volume 81, Issue 1, Pages 31-38.
- Haupt, R. L., Haupt, S. E., 1998. *Practical Genetic Algorithms* (New York: Wiley).
- Ikegami, T., Maezono, T., Nakanishi, F., Yamagata, Y., Ebihara, K., 2001. Estimation of equivalent circuit parameters of PV module and its application to optimal operation of PV system. *Solar Energy Materials & Solar Cells*, 67, 389-395.
- Ketter, Robert L., Prawel, Sherwood P., 1975. "Modern methods of engineering computation"; Mac Graw-Hill book company.
- Pasan Cell Tester CT 801 operating manual., 2004, (www.pasan.ch).
- Phang, Jacob C.H., Chan, S.H. Daniel., 1986. A review of curve fitting error criteria for solar cell I-V characteristics. *Solar cells*, 18, p.1-12.
- Sellami, A., Ghodbane, F., Andoulsi, R., Ezzaouia, H., 1998. An electrical performance tester for PV modules. *Proc. WREC (Florence, Italy)* vol 3, pp 1717–1720.
- Sellami, A., Zagrouba, M., Bouaïcha, M., Bessaïs, B., *Meas. Sci. Technol.* 18 (2007) 1472–1476.
- Sze, S. M., "Physics of Semiconductors Devices", 2nd edition (1982).
- Yu, G.J., Jung, Y.S., Choi, J.Y., Kim, G.S., 2004. A novel two-mode MPPT control algorithm based on comparative study of existing algorithms. *Sol. Energy* 76, 455–463.
- Zagrouba, M., Sellami, A., Bouaïcha, M., *Solar Energy* 84 (2010) 860–866.

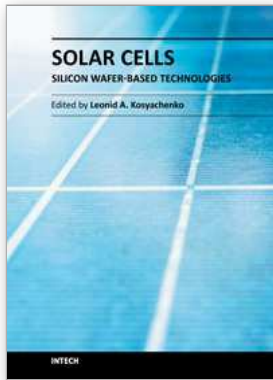

Solar Cells - Silicon Wafer-Based Technologies

Edited by Prof. Leonid A. Kosyachenko

ISBN 978-953-307-747-5

Hard cover, 364 pages

Publisher InTech

Published online 02, November, 2011

Published in print edition November, 2011

The third book of four-volume edition of 'Solar Cells' is devoted to solar cells based on silicon wafers, i.e., the main material used in today's photovoltaics. The volume includes the chapters that present new results of research aimed to improve efficiency, to reduce consumption of materials and to lower cost of wafer-based silicon solar cells as well as new methods of research and testing of the devices. Light trapping design in c-Si and mc-Si solar cells, solar-energy conversion as a function of the geometric-concentration factor, design criteria for spacecraft solar arrays are considered in several chapters. A system for the micrometric characterization of solar cells, for identifying the electrical parameters of PV solar generators, a new model for extracting the physical parameters of solar cells, LBIC method for characterization of solar cells, non-idealities in the I-V characteristic of the PV generators are discussed in other chapters of the volume.

How to reference

In order to correctly reference this scholarly work, feel free to copy and paste the following:

Anis Sellami and Mongi Bouäïcha (2011). Application of the Genetic Algorithms for Identifying the Electrical Parameters of PV Solar Generators, *Solar Cells - Silicon Wafer-Based Technologies*, Prof. Leonid A. Kosyachenko (Ed.), ISBN: 978-953-307-747-5, InTech, Available from:
<http://www.intechopen.com/books/solar-cells-silicon-wafer-based-technologies/application-of-the-genetic-algorithms-for-identifying-the-electrical-parameters-of-pv-solar-generato>

INTECH
open science | open minds

InTech Europe

University Campus STeP Ri
Slavka Krautzeka 83/A
51000 Rijeka, Croatia
Phone: +385 (51) 770 447
Fax: +385 (51) 686 166
www.intechopen.com

InTech China

Unit 405, Office Block, Hotel Equatorial Shanghai
No.65, Yan An Road (West), Shanghai, 200040, China
中国上海市延安西路65号上海国际贵都大饭店办公楼405单元
Phone: +86-21-62489820
Fax: +86-21-62489821

© 2011 The Author(s). Licensee IntechOpen. This is an open access article distributed under the terms of the [Creative Commons Attribution 3.0 License](#), which permits unrestricted use, distribution, and reproduction in any medium, provided the original work is properly cited.