

Design and Prototyping of Autonomous Ball Wheel Mobile Robots

H. Ghariblu, A. Moharrami and B. Ghalamchi
*Mech. Eng. dept., Mechatronics Lab.
Zanjan University
Iran*

1. Introduction

Mobile robots are platforms that are able to move autonomously. Now a day, their use is increased in different areas like, autonomous vehicles, flexible manufacturing and service environments and lunar explorations. A large number of wheeled or tracked platform mechanisms have been studied and developed to prove their mobility and capability as autonomous robot vehicles (Pin, and Killough, 1994), (Kim, et al. , 2003), (Wada, et al. , 2000), (Jung, et al., 2000), (Mori, et al., 1999). For large and heavy outdoor robots, four-wheel car-like driving mechanisms or skid-steer platforms have traditionally been used. These vehicles are quite restricted in their motion (Jarvis, 1997), particularly when operating in tight environments.

In recent years, study of nonholonomic systems has been an area of active research. Nonholonomic systems are characterized by nonintegrable rate constraints resulting from rolling contact or momentum conservation. Nonholonomic behaviors are sometimes introduced on purpose in the design of mechanism, in order to obtain certain characteristics and performances such as those in. One advantage offered by nonholonomic systems is the possibility of controlling a higher number of configurations than the number of actuators actually employed in the system, which is sometimes useful in terms of reducing the system's weight and cost. The nonholonomic constraints cause complexities in trajectory planning and designing of control algorithms for feedback stability of the vehicle system. It is required that a suitable desired trajectory satisfying the above constraint be designed to control a nonholonomic mobile mechanism (Fierro & Lewis, 1997).

On the other hand, holonomic vehicles have been proposed with several advantages and disadvantages, so that there is introduced a control strategy to avoid a nonholonomic constraint of a wheel to implement a holonomic omnidirectional vehicle (Asada & Wada, 1998). Holonomic vehicles, also, have some problems in practical applications such as low payload capability, complicated mechanism and limited accuracy of motion (Ferriere & Raucant, 1998).

Several omnidirectional platforms have been known to be realized by developing a specialized wheel or mobile mechanism. From this point of view, such specialized mechanisms suitable for constructing an omnidirectional mobile robot are summarized as following:

1. Steered wheel mechanism (Chung, et al., 2010), (Wada, et al. , 2000)..

2. Universal wheel mechanism (Song & Byun, 2004).
3. Ball wheel mechanism (Ostrovskaya, et al., 2000), (West, & Asada, 1997), (Ghariblu, 2010), (Ghariblu, et al., 2010).
4. Orthogonal wheel mechanism (Pin, and Killough, 1994).
5. Crawler mechanism (Tadakuma. et.al., 2009).
6. Offset steered wheel mechanism (Udengaard & Iagnemma, 2007).

From the workspace view point, mobile robots must be able to reach at any position on its plane of motion, with any orientation. Thus, their frame must have the three Independent Coordinates of the general plane motion of the rigid body. This can be achieved by means of 2 DOF provided the robot frame kinematics is non-holonomic, but maneuvering is required. Maneuvering can be avoided whenever the mobile robot has 3 DOF. Mobility is enhanced by the use of omni-directional instead of conventional wheels. Omni-directional movement is the ability to travel in any path at any specified orientation. This type of drive system combines translation navigation along any desired path and desired orientation. This ability cause many researchers to study in the subject of omni-directional (holonomic) mobile robots and vehicles.

Generally, a special type of wheels called as omni-wheels are used to achieve Omni-directional movement. Omni-wheels are all based on the same general principle: while the wheel provides traction in the direction normal to the motor axis, it can roll passively in the direction of the motor axis. In order to achieve this, the wheel is built using smaller wheels attached along the outside edge of the wheel. Each wheel provides a torque in the direction normal to the motor axis and parallel to the floor.

The main drawback of such structures is vibrations induced into the complete robot system due to the successive shocks occurring when the contact with the ground shifts from one roller to the next. Other drawbacks of omni-wheels are limited load capacity and surmountable bump height that is limited by the diameter of the rollers, and not by the diameter of the wheels, as with conventional wheels. Therefore, these types of wheels are not appropriate to employ in outdoor applications. To overcome these difficulties, (West, & Asada, 1997), (Ostrovskaya, et al., 2000), and (Asada & Wada, 1998) introduced omni-directional ball wheel vehicles. All of these designs suffer from technical and functional issues include complex design, cost, nonholonomic structure or limited load capacity.

To overcome the above mentioned difficulties and based on our experiment in fabricating a ball wheel robot (BWR-1) (Ghariblu, 2010), the second generation of this robot (BWR-2) is developed (Ghariblu, et al., 2010). In the first generation, a new approach introduced that uses three spherical wheels as main wheels. This design was a good step to develop a new holonomic mobile robotic vehicle. But, after experimental tests, several difficulties were appeared. Most important problems in our former style robot were lack of suspension system, rigid structure of robot, non modular construction of driving system that leads to fixing all driving motor on a common rigid frame, and low effective space between main wheels chassis and floor. These problems are basis to weak operation of robot in passing through rough terrains.

Other drawback was the unwanted locking of ball wheels due to inappropriate structure of their supports to corrupt the overall robot motion on its desired path. To solve the above problems, second generation of a ball wheel mobile robot is designed and constructed.

To improve the robot motion in rough terrains several modification are made on our former robot. The first modification was the modular construction of driving system, which separately fabricated and assembled on this system. Also, proper suspension system

consists of springs and dashpots are added to each driving system. Meanwhile, specific design of the robot solved the trouble of small space between the balls chassis and moving base.

To overcome bearing problem standard ball and socket bearings implemented to ease the balls motion.

The outline of the chapter is as following: Section 2, describes the mechanical and electrical construction of ball wheel robots consist of wheels driving mechanism, chasis and suspension system. Section 3 discusses on new elements of BWR-2 to overcome to drawbacks of BWR-1 robot. Sections 4 and 5 present kinematic and dynamic equations of both robots. Finally, in Section 6 with some simulation studies we show the ability of robot in traversing predefined desired paths.

2. The structure of ball wheel robot

This section introduces the mechanical structure of BWR-1 and troubles find out in that robot. Then we will discuss about modifications utilized in BWR-2 to solve these troubles.

Fig. 1 shows schematic views of BWR-1. The construction of the BWR-1 consisted of a triangular platform and three identical ball wheels that were fixed with bearings between two upper and lower fixing plates. Ball wheels driving were realized by the actuated omni-wheels mounted on a common base over the main base. The locomotion mechanism of this robot consists of three independently actuated ball wheels.

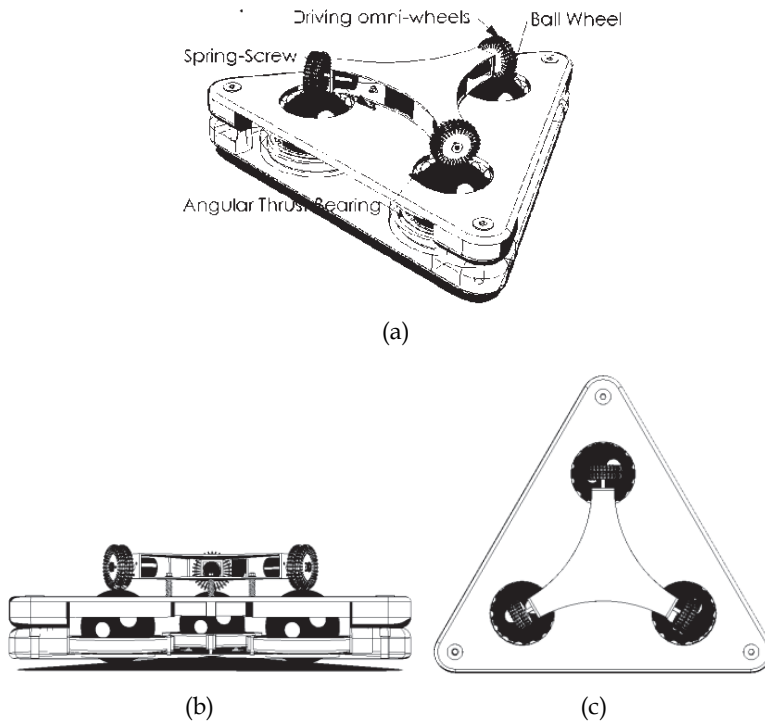

Fig. 1. First type Spherical wheel robot, a) Isometric View, b) Side View, c) Top View

After the design stage and constructing of first prototype of BWR-1, we determined some difficulties in application of this vehicle in real environment, as follows

- a. In specific conditions owing to rigid structure of robot, in passing through uneven ground one of the robot wheels separated from the moving plane. This fact results unwanted deviation of robot motion from its desired path.
- b. Driving wheels and their transmission system were rigidly assembled on a common frame. This fact directed road irregularities and acceleration and deceleration motions to the main body, with a possible degradation to the vehicle required tasks.
- c. Unwanted locking of ball wheels due to inappropriate structure of their supports corrupt the overall robot motion.

Above mentioned troubles in BWR-1 degrades its function for performing requested motions such as rotation and lateral movements.

To solve the above problems and achieve the required characteristics for a high performance, its second generation named as BWR-2 is designed and constructed.

2.1 The architecture of BWR-2

Here, the design specification of new ball wheel omni-directional mobile robot BWR-2 is explained (Fig. 2). The objective of designing BWR-2 is to ensure that new robot meets design specifications and overcome weaknesses of BWR-1.

Performing some experiments on BWR-1 directed us to problems existed in robot structure that was mentioned in the previous section.



Fig. 2. Two different views of BWR-2

BWR-2 robot is an omni-directional mobile platform. Omni-directional design of this robot improves its characteristics for high maneuverability. Consequently, robot can simultaneously move along any desired path with rotation about its geometrical axis.

Same as BWR-1, the new robot BWR-2 is equipped with three balls as main wheels driving by two omni-wheels that transfer motor traction force to the balls. Moreover, three parallel suspension systems consist of springs and dashpots are added to BWR-2 structure. Maximum achievable speed for robot is 3.4 m/s.

To drive the robot, modular and mechanically independent driving system is employed (Fig. 3). Each driving system is driven by a DC motor with reduction ratios of 12:1, consists of a ball as main wheel, and two omni-wheels to transfer motor traction force to the ball, and three parallel suspension systems consists of springs and dashpots.

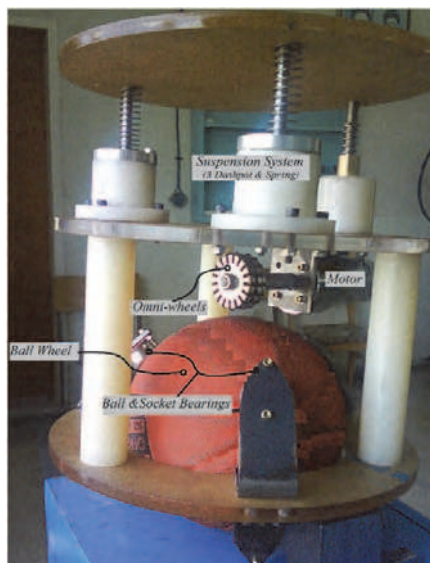

Fig. 3. BWR-2 modular driving system

A list of robot geometric and physical parameters is summarized in Table 1.

| |
|---|
| <ul style="list-style-type: none"> • MAIN BASE Dimension: Equilateral Triangle with 750 mm sides Material: polyamide Weight: 8kg • Ball wheels Dimension: \varnothing 150 mm Material: polyurethane resin Weight: 0.25 kg, • Omni-wheels Dimension: \varnothing 50 mm Material: Aluminum, peripheral wheels covered with plastic o-ring Weight: 0.1 kg • Geared DC motor 120 rpm- 45 Watt, 12 volt • Total weight: 20 kg, without batteries |
|---|

Table 1. Geometric and physical characteristics

Fig. 4 shows the electrical architecture of the BWR. The BWR has an onboard notebook computer. The robot can be controlled remotely through the wireless connection or using a Microsoft game pad USB Sidewinder connected to another USB port of the notebook. Game pad buttons control the movement and rotation of the robot. Three Serial/USB converters are used to connect the robot base. Software drives the motor by the USB hub and the

Serial/USB converters. The robot is powered by two 24V, 7A-H lead-acid batteries. Motor drivers activate DC motors with two omni-wheels assembled on their shaft to transfer motor traction to the ball wheels.

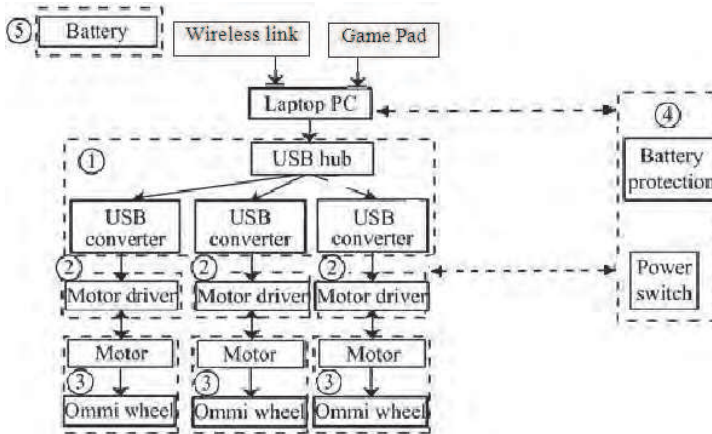

Fig. 4. Electrical architecture of BWR

3. Advantages of BWR-2 robot

Some significant modifications are performed to ensure better function of BWR-2 respecting BWR-1. As bellow

- Corrugated polyurethane resin spherical ball is utilized to generate relative high coefficient of friction regarding to driving omni-wheels and moving surface.
- Handmade bearings of ball wheels changed with standard ball and socket bearings. By this modification locking problem between bearings and ball wheels appropriately solved. Consequently, balls wheels are able to rotate freely according to vehicle desired motion. Each ball is held by six ball and socket bearings fixed on two sides of the frame disk on outside edge of ball wheel to make stable motion (Fig. 3).
- To make adequate driving force between driving omni-wheels and ball wheel doubled omni-wheels are used.
- Finally, differing from BWR-1 that was designed to navigate in indoor applications or flat surfaces, owing to employing new suspension for wheels BWR-2 will be able to navigate in outdoor applications. It is shown in Fig. 5 by adjusting suspension system according to obstacle existed in the robot path; it can easily traverse along uneven ground.



Fig. 5. Wheels adjustment with obstacle owing to proper action of suspension system.

4. Kinematics

Kinematics of both robots assuming horizontal plane movement are similar. The main focus lies in the connection between driving omni-wheels angular velocities and robot velocity. Fig. 6 illustrates a top view of the BWR-1 robot. The common radius of all omni-wheels is r_w and all ball wheels is r_s , and the distance from robot center to the contact points between wheels and floor is r_R . Four sets of coordinates are introduced: The mutually perpendicular unit vectors $\{e_x; e_y; e_z\}$ are fixed in a global non-moving reference frame, with e_x and e_y being parallel to the floor and e_z facing upwards. The unit vectors $\{e'_1; e'_2; e'_3\}$ are also mutually perpendicular. They are fixed on the robot, e'_1 denotes the robot forward direction and e'_3 is parallel to e_z . Note that e_z represents a translational dimension whereas e'_3 is used to express rotational quantities. The third set of coordinates consists of the unit vectors $\{e_{w1}; e_{w2}; e_{w3}\}$, each of them points in the respective wheel's axial direction. The unit vectors $\{e_1; e_2; e_3\}$, are pointing in the wheel peripheral directions. They are linearly dependent on e'_1 and e'_2 and compute as vector cross products:

$$e_i = e'_3 \times e_{wi} \quad , i = 1, 2, 3 \tag{1}$$

The origin of the X' - Y' coordinate system is located in the robot's geometrical center where the omni-wheel axes intersect. The robot orientation α is defined as the angle between e_x and e'_1 .

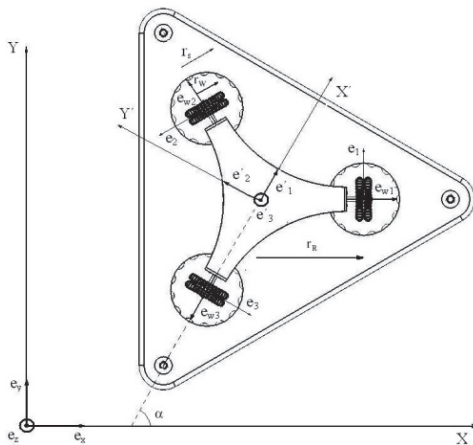

Fig. 6. Coordinate system definition

The robot velocity is expressed by $\dot{X}_R = [\dot{x}, \dot{y}, \dot{\alpha}]^T$ and $\dot{X}'_R = [\dot{x}', \dot{y}', \dot{\alpha}]^T$ in global and body coordinates, respectively. The angular velocity of the omni-wheels are expressed by $\dot{\phi} = [\dot{\phi}_1, \dot{\phi}_2, \dot{\phi}_3]^T$. Matrix T_R^W transforms body coordinates into omni-wheel coordinates, and T_C^R transforms global coordinates into body coordinates. It can be seen that body coordinates and wheels motion are expressed as

$$\begin{cases} -\dot{\phi}_1 r_w = \dot{x}' \sin 60 + \dot{y}' \sin 30 + \dot{\alpha} r_R \\ -\dot{\phi}_2 r_w = -\dot{x}' \sin 60 + \dot{y}' \sin 30 + \dot{\alpha} r_R \\ -\dot{\phi}_3 r_w = 0 - \dot{y}' + \dot{\alpha} r_R \end{cases} \quad (2)$$

Matrix form of Eq. 2 is

$$\begin{bmatrix} \dot{\phi}_1 \\ \dot{\phi}_2 \\ \dot{\phi}_3 \end{bmatrix} = T_R^W \begin{bmatrix} \dot{x}' \\ \dot{y}' \\ \dot{\alpha} \end{bmatrix}$$

Where

$$\begin{bmatrix} \dot{x}' \\ \dot{y}' \\ \dot{\alpha} \end{bmatrix} = T_G^R \begin{bmatrix} \dot{x} \\ \dot{y} \\ \dot{\alpha} \end{bmatrix} \quad (3)$$

Substituting Eq. 3 into Eq. 2, the relation between $\dot{\phi}$ and \dot{X}_R is derived.

$$T_R^W = \frac{-1}{r_w} \begin{bmatrix} \frac{\sqrt{3}}{2} & \frac{1}{2} & r_R \\ \frac{\sqrt{3}}{2} & \frac{1}{2} & r_R \\ 0 & -1 & r_R \end{bmatrix}, \quad T_G^R = \begin{bmatrix} \cos(\alpha) & \sin(\alpha) & 0 \\ -\sin(\alpha) & \cos(\alpha) & 0 \\ 0 & 0 & 1 \end{bmatrix} \quad (4)$$

5. Dynamics

In this section, to simplify the dynamic equations, it is assumed that robot motion lies in a horizontal surface without obstacles. Therefore, to derive the dynamic equations, the action of suspension system would be neglected. Fig. 7 shows the masses and inertias of the robot. The robot is modeled as a set of three different rigid bodies. The robot chassis is illustrated as a triangle. Its mass m_c contains the chassis, motors, battery, and all other parts rigidly attached to it, its moment of inertia with respect to the Z' axis is $I_{z'}$. Its mass center is assumed to be located on the Z' axis. The three omni-wheels are same, with masses of m_w . The mass center of the omni-wheels is located on their axis of rotation at the distance r_R from the robot's center. Also, moments of inertia about the axis passing through their center and parallel to Z' axis and axis of rotation are $I_{wz'}$ and I_{wa} , respectively. Also, the three ball wheels are the same, with masses of m_s . their moments of inertia about principle axis of rotation is I_s . The robot total mass m_R consists of the chassis mass plus the wheels masses. Its center of mass is assumed to be located on the Z' axis at the height h_M above the ground:

$$\begin{aligned} m_R &= m_c + 3m_w + 3m_s, \\ I_R &= I_{z'} + 3(I_{wz'} + I_s + (m_s + m_w) r_R^2) \end{aligned} \quad (5)$$

Assuming horizontal motion for the robot, the gravitational potential energy may be omitted. The Euler-Lagrange equations of motion for the simplified robot model are

$$\frac{d}{dt} \left(\frac{\partial T}{\partial \dot{q}_i} \right) - \frac{\partial T}{\partial q_i} = Q_i, \quad i = 1, 2, 3 \tag{6}$$

The robot's generalized coordinates is expressed with its omni-wheels angular motion $[\dot{q}_1, \dot{q}_2, \dot{q}_3]^T = [\dot{\phi}_1, \dot{\phi}_2, \dot{\phi}_3]^T$. Therefore, associated generalized force Q_i , are the motor torques applied to the actuators attached to the driving omni-wheels, $[Q_1, Q_2, Q_3]^T = [T_1, T_2, T_3]^T$. The robot's kinetic energy T is $T = T_{trans} + T_{rot}$;

$$T_{trans} = \frac{1}{2} m_R (\dot{x}^2 + \dot{y}^2), \quad T_{rot} = \frac{1}{2} I_R \dot{\alpha}^2 + 3 \sum_{i=1}^3 (I_{wa} + ((\frac{r_w}{r_s})^2 + (\frac{r_w}{r_R})^2) I_s) \dot{\phi}_i^2 \tag{7}$$

Components of \dot{x}, \dot{y} and $\dot{\alpha}$ in the Eq. (7) are substituted from Eqs. (2) and (3) with respect to actuators angular velocities $\dot{\phi}_1, \dot{\phi}_2$ and $\dot{\phi}_3$. Computing the derivatives in the Euler-Lagrange equations and rearranging terms, the equations of motion can be expressed in its closed form as

$$M(\phi)\ddot{\phi} + C(\phi, \dot{\phi}) + G(\phi) + D(\phi) = T \tag{8}$$

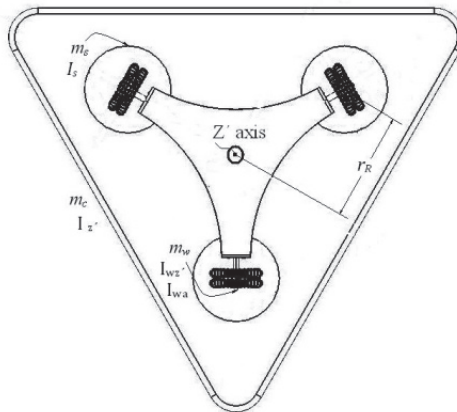

Fig. 7. Robot mass and inertia properties

6. Simulation study

Some numerical examples have been performed based on equations developed the previous section to simulate the behavior of the robot. Hence, a circular path is used with two scenarios of motion for the vehicle. Then, associated equivalent motor torques and wheels angular motions are computed, and overall characteristics of the robot are analyzed and evaluated.

The given trajectory is a circle with radius of 1.5 m . The motion of robot starts from the rest with constant acceleration and reaches to its maximum velocity V_{max} in the first 90° , then moves with constant velocity V_{max} in the next 180° of the path, and, finally decelerates constantly in the last 90° to reach at rest. The overall time of the motion is equal $t=6.0$ s.

In the first scenario, as shown in the Fig. (8-a), during the motion X' axis that shows forward direction, is directed tangent to the robot path. The corresponding actuators angular velocities and torques are shown in Fig's (8-b) and (8-c).

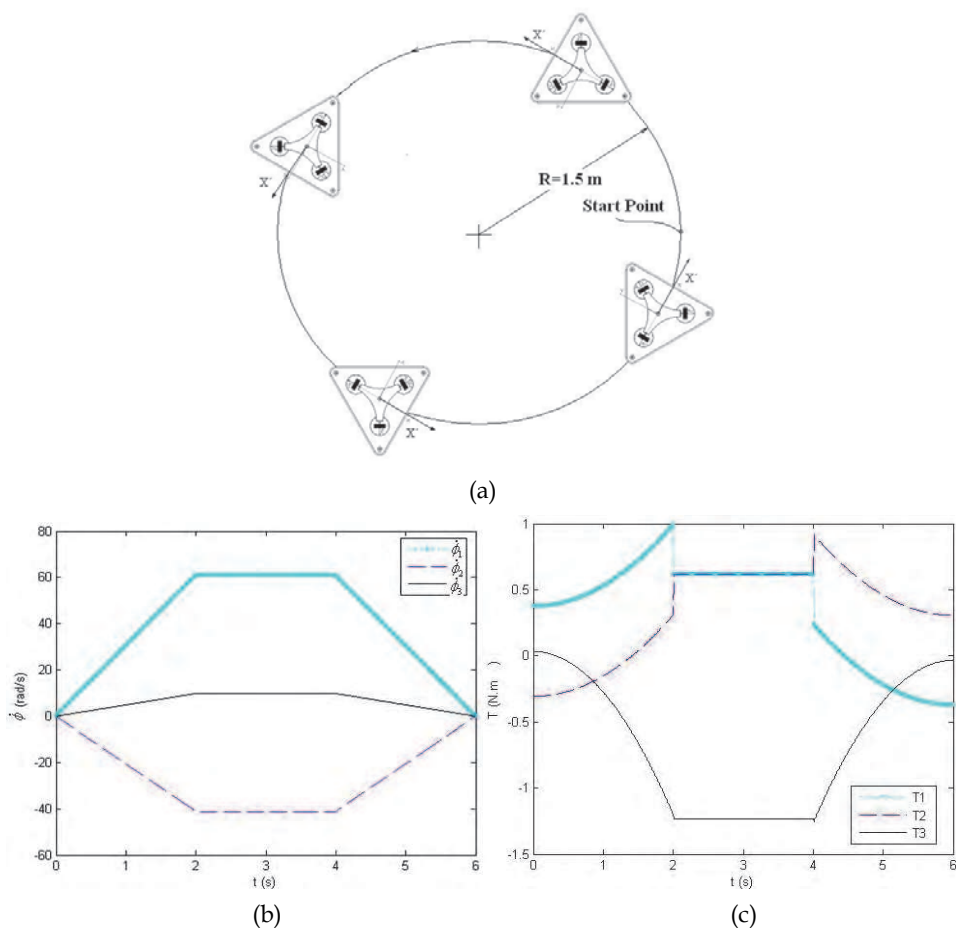

Fig. 8. a) Robot moving with Orient tangent to the path, b and c) corresponding actuators angular velocities and torques

In the second scenario, as shown in the Fig. (9), direction of the robot during the motion is fixed. The corresponding actuators angular velocities and torques are shown in Fig's (9-a) and (9-b).

According to the simulation results, it can be seen that both ball wheeled platforms are able to move on a given path with different scenarios.

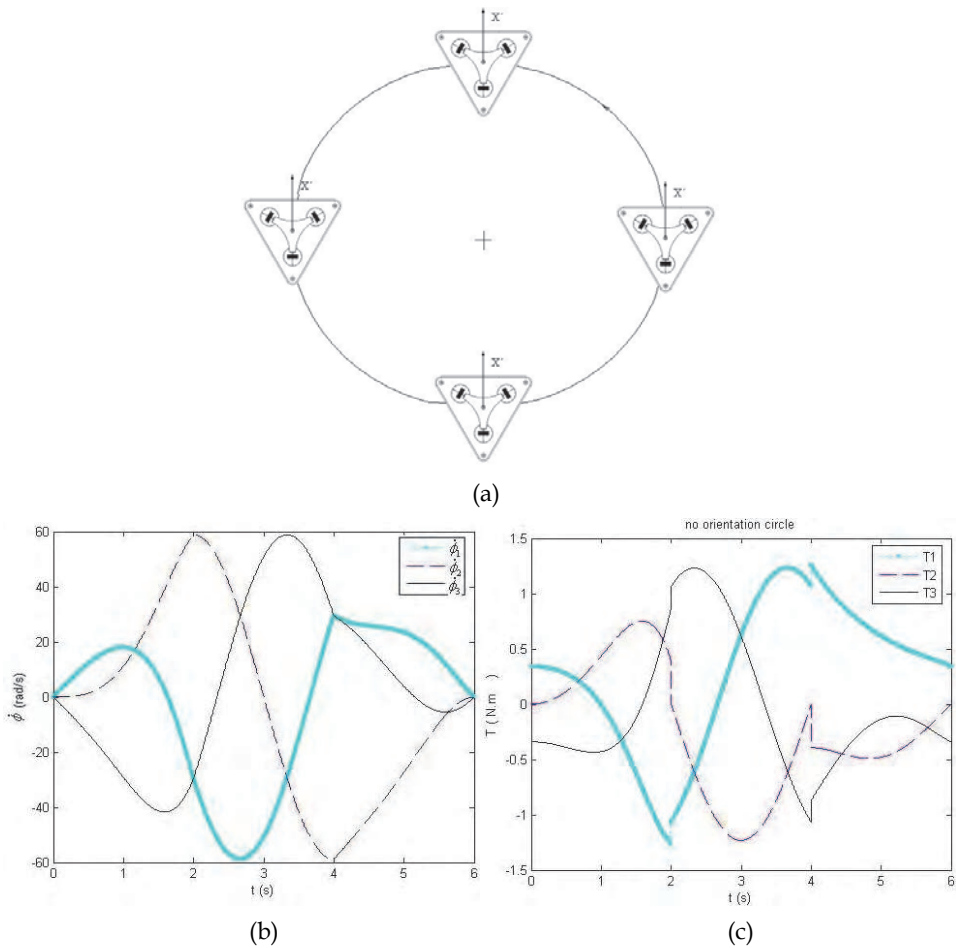

Fig. 9. a) Robot moves with fixed direction, b and c) corresponding actuators angular velocities and torques

7. Conclusion

The concept, design and implementation of an autonomous spherical wheel mobile robots, named as BWR-1 and BWR-2 has been presented. A prototype of such platforms has been built using three spherical wheels driven by classical omni-wheels. These robots are omnidirectional, and so simultaneous longitudinal, transverse and rotational motions are possible. These robots have the same mobility as robots equipped with classical universal wheels that are suitable for indoor applications. But, these robots owing to larger diameter of ball wheels are able to move in outdoor purposes, especially BWR-2 that provides a modular driving system equipped to suspension system. Future work will employ new features on the prototype for autonomous navigation such as optic encoders mounted on passive universal wheels and camera for vision.

8. References

- Asada H., & Wada M., (1998), "The Superchair :A Holonomic Omnidirectional Wheelchair with a Variable Footprint Mechanism", *Total Home Automation and Health/Elderly Care Consortium* .
- Chung W., Moon C., Jung C., & Jin J., (2010), "Design of the Dual Offset Active Caster Wheel for Holonomic Omni-directional Mobile Robots", *Int. J. of Advanced Robotic Systems*, Vol. 7, No. 4., pp. 101-106.
- Ferriere L. & Raucent B., (1998), "ROLLMOBS, a new universal wheel concept", *Proceedings of the 1998 IEEE, International Conference on Robotics & Automation*, Leuven, Belgium, pp. 1877-1882.
- Fierro R. & Lewis F. L., (1997), "Control of a Nonholonomic Mobile Robot: Backstepping Kinematics into Dynamics", *Journal of Robotic Systems*, Vol. 14(3), pp. 149-163.
- Ghariblu H., "Design and Modeling of a Ball Wheel Omni-Directional Mobile Robot", *ICIET 2010*, March. 2010, Bali, Indonesia.
- Ghariblu H., Moharrami A., Ghalamchi B., Bayat N., (2010), "Design and Modeling of a Ball Wheel Mobile Robot 2 (BWR-2)", *2010 1th International Conference on Mechanical Engineering, Robotics and Aerospace*. Bucharest, Romania.
- Jarvis R., (1997), "An autonomous heavy duty outdoor robotic tracked vehicle", *IROS '97*, Vol.1, pp. 352 - 359.
- Jung M.-J., Kim H.-S., Kim S., & Kim J.-H., (2000), "Omni-Directional Mobile Base OK-II", *Proc. IEEE Int. Conf. on Robotics and Automation*, pp. 3449-3454.
- Kim D. S., Kwon W. H., & Park H. S., (2003). ' Geometric Kinematics and Applications of a Mobile Robot ", *Int. J. of Control, Automation, and Systems*, Vol. 1, No. 3, pp. 376-384.
- Mori Y., Nakano E., Takahashi T., & Takayama K., (1999), "Mechanism and Running Modes of New Omni-Directional Vehicle ODV9", *JSME International Journal, Series C*, 42(1): 210-217.
- Ostrovskaya, J. Angeles & Spiteri R., (2000), "Dynamics of a Mobile Robot with Three Ball-Wheels", *The Int. J. of Robotics Research*, Vol. 19; pp. 383-393.
- Pin F. G., & Killough S. M., (1994), "A New Family of Omnidirectional and Holonomic Wheeled Platforms for Mobile Robots" *IEEE Transactions on Robotics and Automation*, Vol. 10, No. 4, pp. 480-489.
- Song J. & Byun K., (2004), "Design and Control of a Four-Wheeled Omnidirectional Mobile Robot with Steerable Omnidirectional Wheels", *J. of Robotic Systems*, Vol. 21(4), pp. 193-208.
- Tadakuma K. et.al., (2009), "Basic Running Test of the Cylindrical Tracked Vehicle with Sideways Mobility", *The 2009 IEEE/RSJ Int. Conf. on Intelligent Robots and Systems*, pp.1679-1384.
- Udengaard M.& Iagnemma K., (2007), "Kinematic Analysis and Control of an Omnidirectional Mobile Robot in Rough Terrain", *. IROS 2007*, pp. 795-800.
- Wada M., Takagi A. & Mori S., (2000), "Caster Drive Mechanisms for Holonomic and Omni-directional Mobile Platforms with no Cover Constraints", *Proc. IEEE Int. Conf. on Robotics and Automation*, pp. 1531-1538.
- West M., & Asada, H., (1997). "Design of ball wheel mechanisms for omnidirectional vehicles with full mobility and invariant kinematics". *ASME J. of Mechanical Design*, 119(2):153-161.

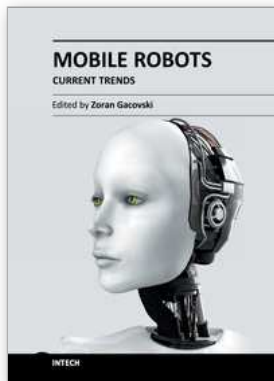

Mobile Robots - Current Trends

Edited by Dr. Zoran Gacovski

ISBN 978-953-307-716-1

Hard cover, 402 pages

Publisher InTech

Published online 26, October, 2011

Published in print edition October, 2011

This book consists of 18 chapters divided in four sections: Robots for Educational Purposes, Health-Care and Medical Robots, Hardware - State of the Art, and Localization and Navigation. In the first section, there are four chapters covering autonomous mobile robot Emmy III, KCLBOT - mobile nonholonomic robot, and general overview of educational mobile robots. In the second section, the following themes are covered: walking support robots, control system for wheelchairs, leg-wheel mechanism as a mobile platform, micro mobile robot for abdominal use, and the influence of the robot size in the psychological treatment. In the third section, there are chapters about I2C bus system, vertical displacement service robots, quadruped robots - kinematics and dynamics model and Epi.q (hybrid) robots. Finally, in the last section, the following topics are covered: skid-steered vehicles, robotic exploration (new place recognition), omnidirectional mobile robots, ball-wheel mobile robots, and planetary wheeled mobile robots.

How to reference

In order to correctly reference this scholarly work, feel free to copy and paste the following:

H. Ghariblu, A. Moharrami and B. Ghalamchi (2011). Design and Prototyping of Autonomous Ball Wheel Mobile Robots, Mobile Robots - Current Trends, Dr. Zoran Gacovski (Ed.), ISBN: 978-953-307-716-1, InTech, Available from: <http://www.intechopen.com/books/mobile-robots-current-trends/design-and-prototyping-of-autonomous-ball-wheel-mobile-robots>

INTECH

open science | open minds

InTech Europe

University Campus STeP Ri
Slavka Krautzeka 83/A
51000 Rijeka, Croatia
Phone: +385 (51) 770 447
Fax: +385 (51) 686 166
www.intechopen.com

InTech China

Unit 405, Office Block, Hotel Equatorial Shanghai
No.65, Yan An Road (West), Shanghai, 200040, China
中国上海市延安西路65号上海国际贵都大饭店办公楼405单元
Phone: +86-21-62489820
Fax: +86-21-62489821

© 2011 The Author(s). Licensee IntechOpen. This is an open access article distributed under the terms of the [Creative Commons Attribution 3.0 License](#), which permits unrestricted use, distribution, and reproduction in any medium, provided the original work is properly cited.