

# The Investigation of Influence Polyisobutylene Additions to Kerosene at the Efficiency of Combustion

V.D. Gaponov<sup>1</sup>, V.K. Chvanov<sup>1</sup>, I.Y. Fatuev<sup>1</sup>, I.N. Borovik<sup>2</sup>, A.G. Vorobiev<sup>2</sup>,  
A.A. Kozlov<sup>2</sup>, I.A. Lepeshinsky<sup>2</sup>, Istomin E.A.<sup>2</sup> and Reshetnikov V.A.<sup>2</sup>

<sup>1</sup>OAO "NPO Energomash"

<sup>2</sup>Moscow Aviation institute (State Technical University)  
Russia

## 1. Introduction

Liquid rocket engines reached high efficiency at present. Next improvement of their energetic, mass and reliability characteristics is labor-intensive and high expensive process. It is famous, that addition of polymers to carbonhydrogen fuels decrease substantially hydraulic losses at the friction in pipelines and aggregates of engines. Fulfilled in "NPO Energomash" the programme investigation influence of additions polyisobutylene to kerosene at the hydraulic tests exploited engines was showed, that the decrease of the hydraulic losses may be more 20% [7]. The use of this effect lets or increase pressure in the combustion chamber at constant heat intensity of the turbine or to increase the resource of the engine at the base decrease heat intensity of turbine.

The question regarding influence addition at the combustion efficiency stated not clear. This investigation for full-sized engines though doesn't required fabrication new material part, but is completed and expensive process analogically fire tests of the engine.

Most likely mechanism influence of addition at combustion efficiency may be pulverization of liquid fuel. The program investigation of this mechanism was developed at department 202 of MAI [3]. This program included two steps. The first step was directed at obtaining characteristics of pulverization one from mixed head liquid rocket engine of small thrust MAI-202K, working at kerosene and gaseous oxygen. Characteristics of pulverization of the mixing head at clean kerosene and kerosene with additions were diagnosed by dispersal of drops, obtained at automatically measurement system. Method dispersal measurement was based at change intensity projecting at the screen reflected from drops laser ray.

The second step consist fire tests of engine MAI-202 with seven swirl injectors mixing head and oxygen curtain. Tests were fulfilled at the fire stand of department 202 MAI, at the same regime of work, but at different fuels: clean kerosene and kerosene with additions 0.05-0.01% polyisobutylene.

In the article detail materials are introduced about results as hydraulic, so and fire tests, measured equipment, design of mixing head, characteristics of pipeline. Combustion efficiency was obtained as ratio of experimental value mass flow complex  $\beta^{exp}$  to thermodynamic value mass flow complex  $\beta^t$ .

## 2. Composition and structure of test stand

Experimental investigation of influence 0.05% polyisobutylene additions to kerosene was fulfilled at the test-bad № 72-2 department 202 MAI for fire tests liquid rocket engines of small thrust (LRE STh) at ecological clean propellants [2]. Hydraulically pipe line of kerosene is selection pipes from stainless steel of variable diameter (4-16mm) total length 8.12m. Pipe line connects kerosene tank with investigated mixing head and consists control valve, filters (net 7 and 70 micro meters), sensors of mass flow, pressure and temperature (Fig. 1).

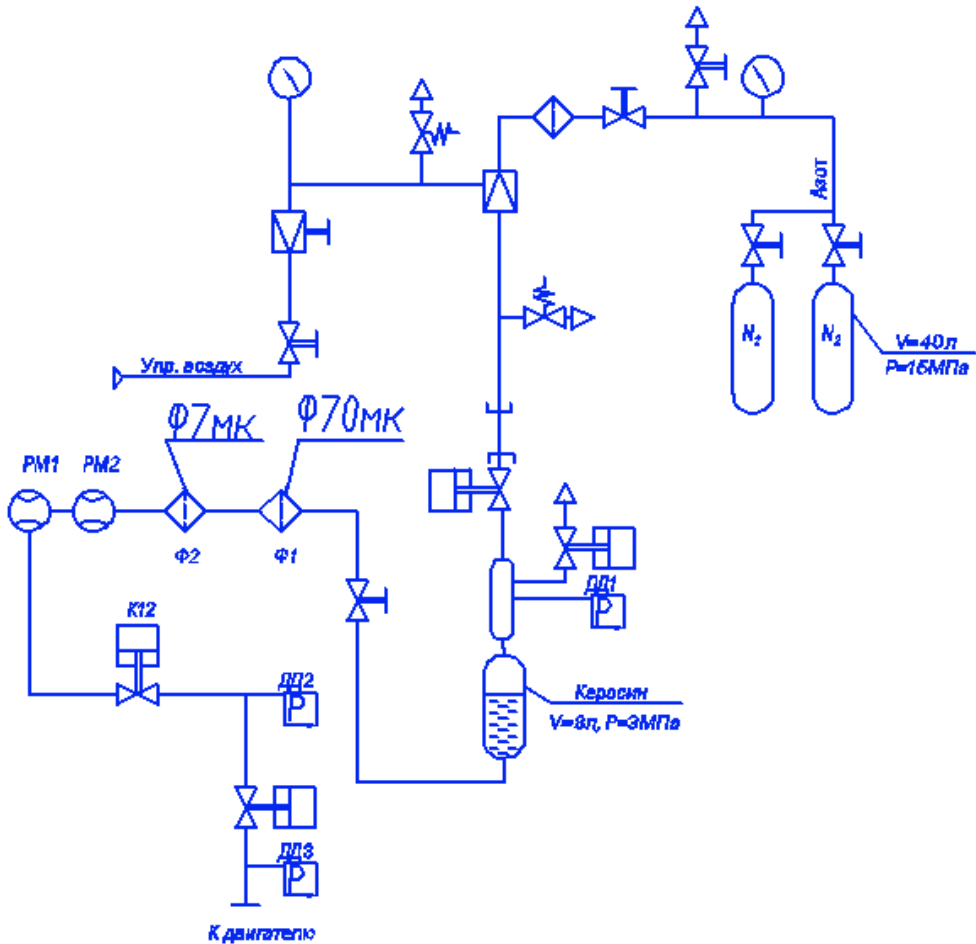

Fig. 1. Kerosene feeding system.

Take into account fire danger of mixture drops of kerosene with oxygen, for the obtaining characteristics of pulverization the special drops-trap was designed and fabricated. Scheme of this drops-trap is showed at Fig. 2.

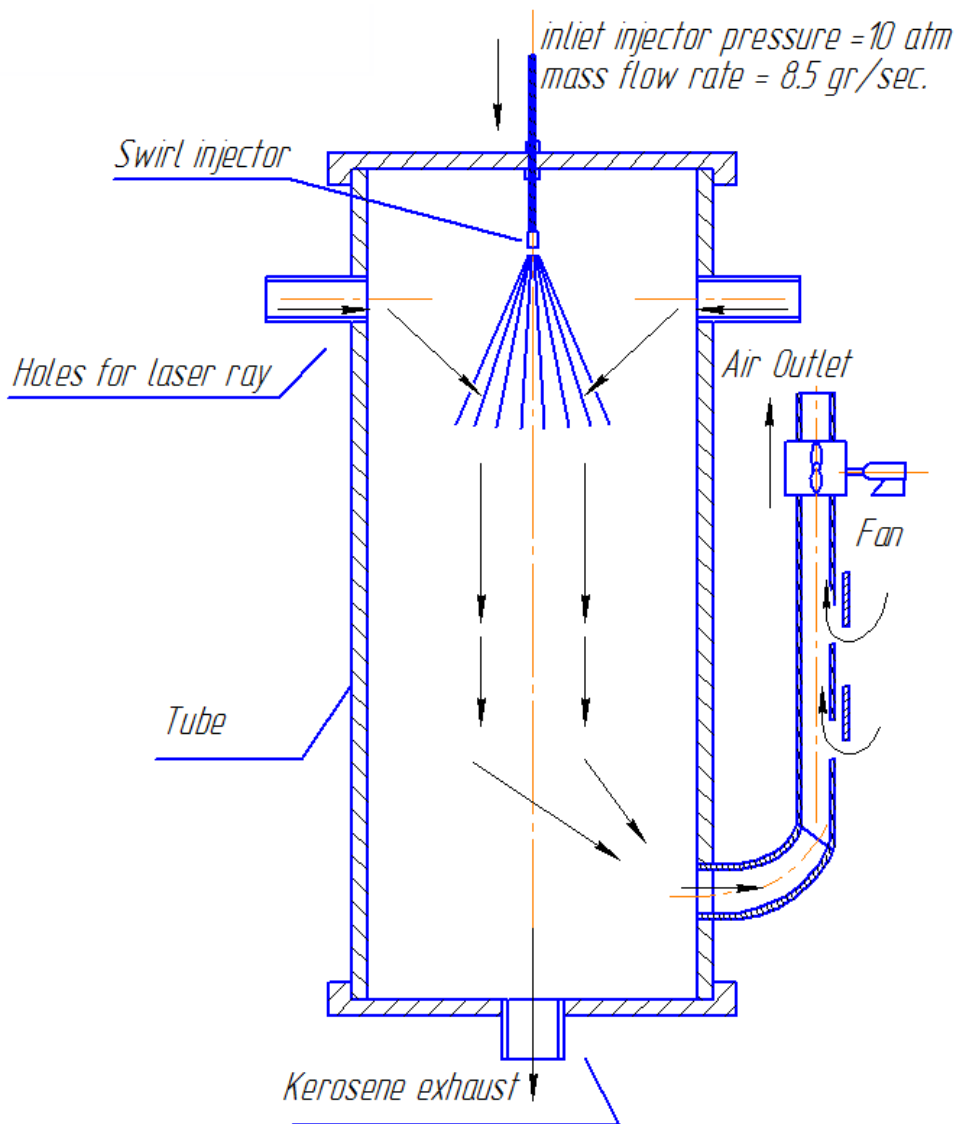

Fig. 2. Scheme of drops-trap.

Drops-trap consists from tube diameter 400mm, upper top with mounted kerosene pipe with injector (or mixing head), two diametrically opposite orifices for registration quality of pulverization, low lid with branch pipe drain of kerosene and system of forced extraction mixture with fan in explosive-protected fulfillment.

Vertical position of drops-trap corresponds vertical position of tested engine and guarantees the same influence of gravitation forces at the torch of pulverization. Photos of drops-trap are presented at Fig. 3. Photos of working laser system during test presented at Fig. 4.

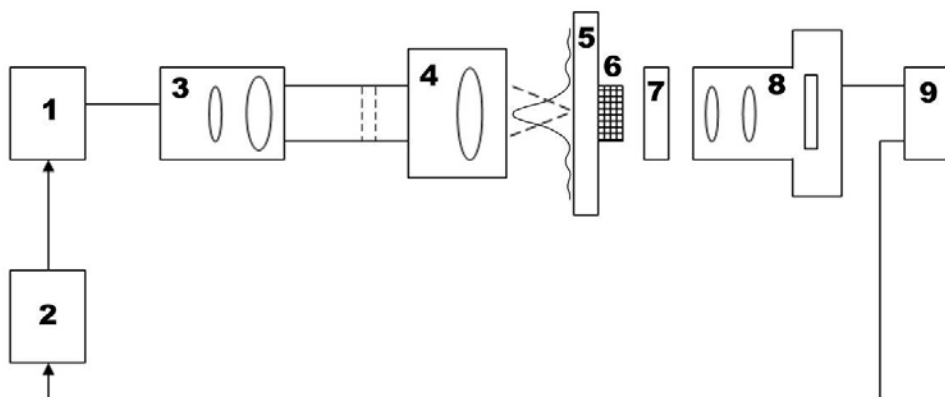

Fig. 3. Photo of drops-trap.



Fig. 4. Laser ray goes through the spray.

System of distanced laser measurer guarantees registration diagram of dispersion of aerosol cloud at the distance till 2 meters from measured volume. In result of mathematical computing sizes and concentration parts are definite (fase-dispersia composition).Structure scheme of measured system is presented at Fig. 5.



- 1 - bloc of laser radiators;
- 2 - control bloc of laser radiators;
- 3 - bloc of transfer optical system;
- 4 - bloc of entranced optical system;
- 5 -light dispersion screen;
- 6 -mask;
- 7 - filter;
- 8- digital camera;
- 9 - computer.

Fig. 5. Structure scheme of a base distanced laser measurer:

Bloc of transferred lenses 3 contains field diaphragm and, some times, collimator forming probe-rays and sizes of measured volume. Bloc of entranced optics contains Furie-lenses, having focus-distance 50-100 cm and light diameter 10-20 cm.

Focus distance of lenses, entranced in collimator, is changed from 10mm till 20cm. Because of small sizes of parts(2-10micron)and big distances(till 2m) diameter most information part of spatial specter, in which about 90% energy dispersed radiation is consisted , is obtained more 20 cm.

Therefore, in order to fix this specter directly at photo-matrix, it is necessary to fabricate it's specially, but it go to big expenditures. In order to fix this spatial specter by series digital camera 8, in frequency plate bloc of entrance optics was mounted light dispersion screen 5, which visualizes the spatial specter. In order don't spoil matrix of camera 8 by direct laser ray, behind screen 5 sometimes expediently to place mask 6, absorbed direct laser radiation. Sometimes, in order to decrease light-dispersion between elements of screen 5, mask is placed before screen. For decrease influence of background light before lenses of camera 8 may to place interference light-filter 7. For two lengths wave of laser radiation light-filter may by changed or special to fabricate. The spatial specter, fixed by digital camera 8, goes in computer 9, where with help of special software the sizes and concentrations parts of

aerosol are calculated. Control of laser radiations is realized across computer 9 (for increase of the mobility notebook is used).

Transferred bloc of measurer contains half-conductor laser 1 (Fig. 6) (length wave 650 nm, type of laser KLM-650/20) and field diaphragm 2mm, which decrease diameter of laser ray, tested measured volume with drops of pulverized.

Light, distributed in direct direction 4 and under small angles, put at Furie-linse 5, in focal surface of which is placed screen 6. Focus distance of Furie-linse equal 500mm, light diameter 200mm. Screen was fabricated from glass, mated with one side and thickness 3mm, sizes 300x300mm.

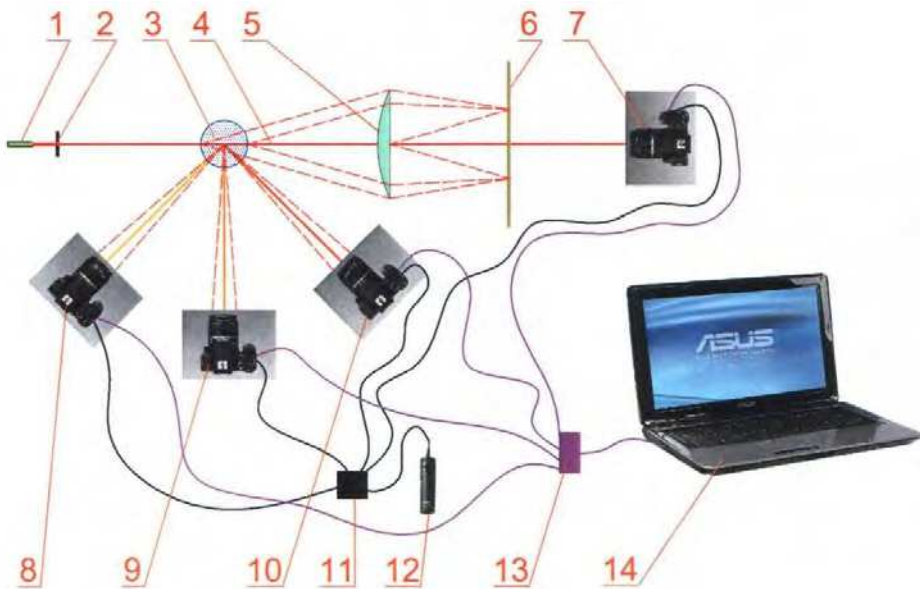

Fig. 6. Principle scheme of system for measurement distribution drops at sizes.

The distribution of light intensity in focal surface of linse (part of indicatrisse, corresponding small angle of dispersion) is fixed by digital camera 7 (Canon EOS 1000P). Furie linse 5, screen 5 and digital camera 7 entrance in composition reception optoelectronic bloc, intended for measurement characteristics dispersion of kerosene cloud in diapason of measurement 1-10micron. For diapason of measurement 0.2-2micron in reception bloc are introduced additional: digital camera8, fixed opposite dispersion, camera 9, fixed dispersed light under straight angle, and camera10, fixed light , dispersed in direct direction, but at angles more 100°(at angles, going out from limits of small angle dispersion).Montage of cameras 8 and 10 under angles regarding main optical axis  $\alpha$  and  $(180^\circ - \alpha)$  and lets use for measurement aerosol sizes method asymmetric of indicatrisse of dispersion. This does more simple the treatment of results. Registration of dispersed light by all cameras fulfilled simultaneously. This reaches by use commutater 11 and control bench of photography 12. Control of cameras 7-10 is realized across USB-divider13 and computer 14. It is possible and hand regime control of cameras. Information entrances across USB- divider 13 in computer 14 fixed these cameras and is treated.

If diameter nozzle of model injector, used during test, equal 0.8mm, that quantity drops with diameter less 2 micron will be not significant, therefore the use cameras 8, 9 and 10 in test not certainly.

### 3. The investigation of influence polyisobutylene additions to kerosene at the dispersion of pulverization

For the treatment obtained drops and calculation parameters of dispersion of aerosol cloud the program is used, developed in MAI at department 201 and realized at the base packet MATLAB (Fig. 7).

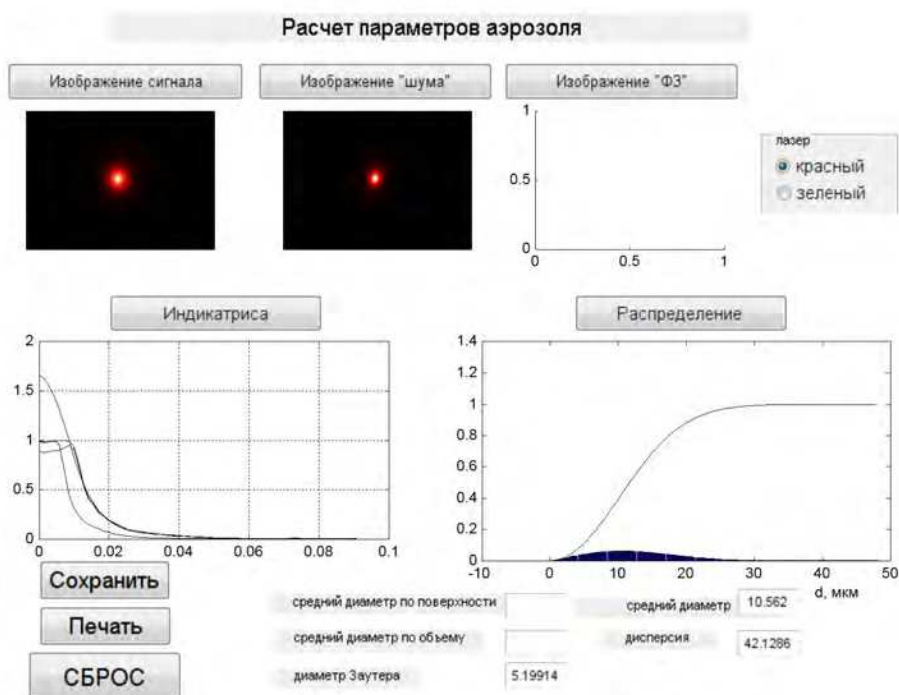

Fig. 7. Interface program calculation of parameters aerosol dispersion.

Laser device is montage at two controlled by altitude tables, placed at different sides from drops-trap (Fig. 8). Axes of scanner ray go in orifices of drops-trap.

In order to separate factor influence of molecules polyisobutylene at the pulverization, the cone of pulverization of single swirl injector with geometrical characteristic  $A = Rr_{nozzle} / (nr_{in}^2) = 3.2$  and nozzle diameter 0.8 mm was analyzed. Distance from nozzle cut off till surface of scanning consists 60 mm.

Estimation of quality of dispersion for common surface area defined by Sauter's diameter parameter. Diameter Sauter is diameter of thermometric drop which has volume\surface area coefficient equal middle volume\surface area coefficient calculated of whole drops in volume.



Fig. 8. Laser device mount in the fire stand.

Results investigation pulverization of centrifugal injector are presented in Table 1.

Presence of addition	Mass flow g/s	Pressure of pressurization, atm	Pressure before valve, atm	Pressure before injector, atm	$\Delta p_{inj}$ atm	$\Delta p_{pipe}$ line, atm	Diameter Sauter's, micron
Without of addition	4,45	4.5	4.8	3.83	0.97	0.7	5.199
Without of addition	5.0	5.44	5.77	4.72	1.05	0.67	4.56
With addition	4.2	12.0	4.6	3.55	1.05	8.4	3.48
With addition	5.38	14.8	6.44	5.44	1.0	9.36	2.94

Table 1.

Analysis of obtained results lets to approve, that 0.05% addition in polyisobutylene in kerosene to improve quality of pulverization ( at equal mass flow of kerosene), about this show decrease of diameter Sauter approximately in 1.5 times. We may white better quality of pulverization during fire tests, because by antypressure in combustion chamber quality of pulverization will be better [5].

It is well known, that median diameter of drops during the pulverization of liquid by swirl injector is obeying the dependence [6]:

$$d_m/d_c = 47.8 / (A^{0.6} \Pi^{0.1} \text{Re}^{0.7}),$$

$$\Pi = \eta_L^2 / \rho_L \sigma_L d_c,$$



$$Re = \rho_L W_e d_c / \eta_L ,$$

where  $\rho_L, \eta_L, \sigma_L$  - density, dynamic viscosity coefficient and surface tension of liquid,  $A$  - geometrical characteristic of injector,  $W_e$  - equivalent velocity of flow,  $d_c$  - nozzle diameter of injector. Then  $d_m/d_c \sim \sigma_L^{0.1} \eta_L^{0.5}$ , so fineness of pulverization improve when viscosity and surface tension are decrease in case if geometrical characteristic of injector and pressure drop not change.

Therefore, there is interest of directly measurement of viscosity and surface tension of kerosene with additions of polyisobutylene for physical interpretation of pulverization process.

#### 4. Investigation influence of polyisobutylene addition to kerosene at the hydraulic resistance of pipe line

For normal kerosene the mass flow rate is 12 gr/sec for feed pressure 10 atm in filter/no filter cases. For kerosene with polyisobutylene addition the mass flow is 4 gr/sec if filter exist on the pipe line and 16 gr/sec if filter absent on the pipe line.

Result (Fig. 9) show that 7 micron filter increase hydraulic loss even if length of pipe line is not big. If case using this kind of filters in LRE pipe lines the hydraulic loss will be sizeable in the cooling jacket of combustion chamber. Without 7 micron filter the hydraulic loss of pipe line increase. The influence of 70 micron filter on hydraulic loss not defined.

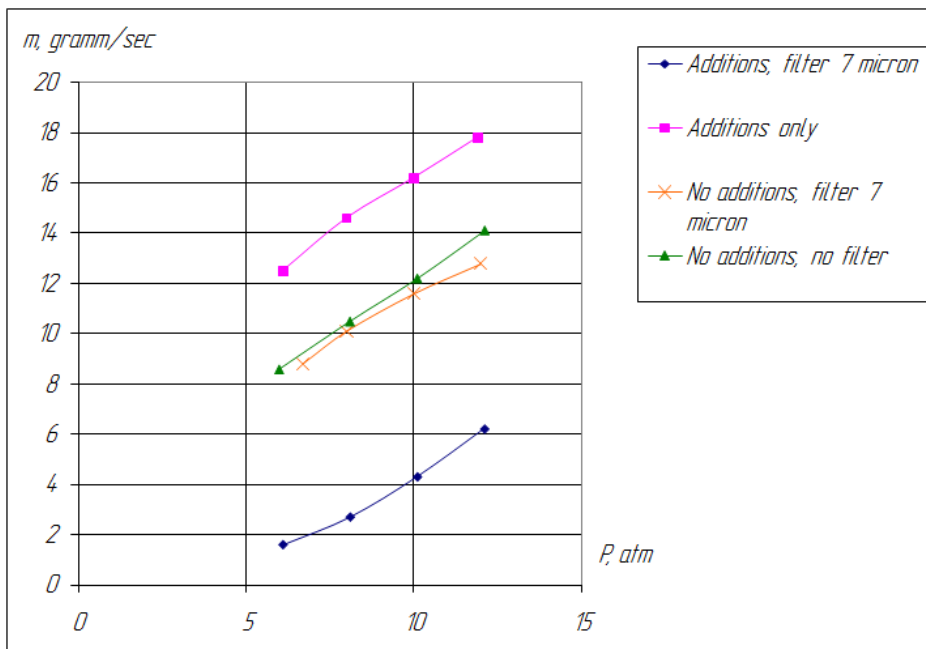

Fig. 9. Feeding pressure/mass flow rate dependency.

## 5. Design of LRE of small thrust for fire tests

Combustion efficiency of propellant in the combustion chamber depends not only from quality pulverization of injector. It depends and from a lot of additional factors: mass flow ratio, number of injectors and scheme its placement at mixing head, combustion chamber pressure, system of inner cooling and others. It is clear, that for separation influence of addition to kerosene it is necessary to fulfill two fire tests at the same engine and the same regime parameters.

For realization fire tests with the use addition of polyisobutylene to kerosene in MAI was developed engine MAI-200-7OK at propellant gaseous oxygen and kerosene (see Fig. 10 - Fig. 12) [3, 8, 9].

A small number of experiments and the difference in the initial parameters of the experiments cannot define exact dependency of polyisobutylene additions on the quality of the spray component.

To determine the effect of polyisobutylene additions on the quality of the spray component is necessary to continue experimental work for a set of statistics.

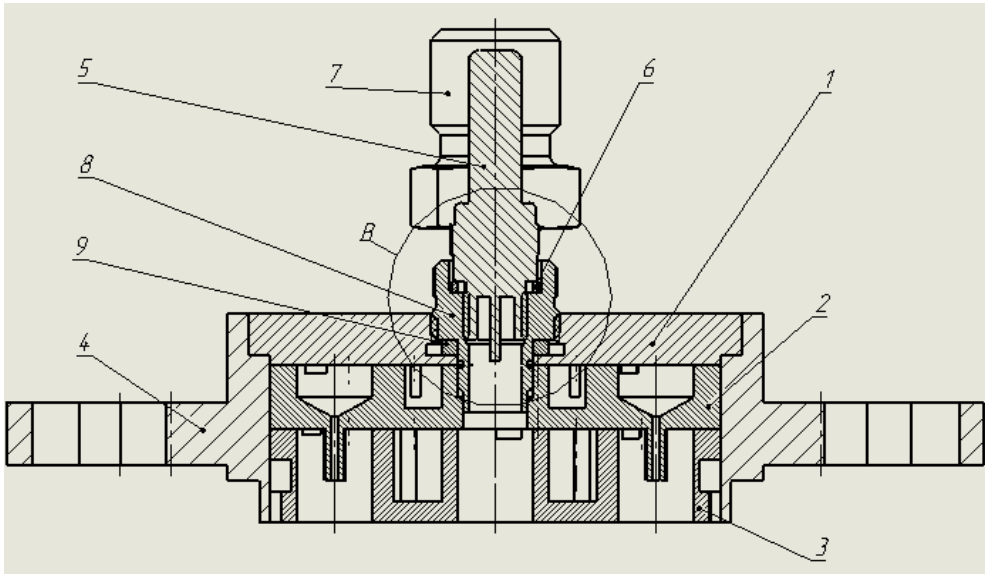

Fig. 10. Drawing of mixing head. 1.top of head, 2.plate of fuel, 3.plate of oxygen,4.flange, 5.candle of ignition, 6. compression of candle, 7.connecting pipes for components, 8.bush of candle, 9.compression of the bush.

Demountable head of engine was fulfilled at technology soldering of plates, bloc from witch place in body-flange. Head has 6 bipropellant swirl injectors with inner stage of fuel and outside open stage of oxidizer. Components go in any injector across two tangencies channels. Ignition of mixture is realize by electrical discharge in the electrical candle, placed in central part of the head. Candle is placed in open volume, in which oxidizer and fuel go during tangential channel like for injectors. Control mass flow of kerosene in volume of

ignition is realized with help of bush with orifices given section. Candle works from electrical high voltage discharger with frequency 200 Hz.

Fuel goes across connecting pipe in central collector and distributed on radial grooves to tangential channels (Fig. 13).

Oxidizer goes in the head across connecting pipe, later goes across plate of fuel, enters in central collector and distributed at radial grooves to tangential channels (Fig. 14).Part of oxidizer from radial grooves at special orifices goes at inner (curtain) cooling.

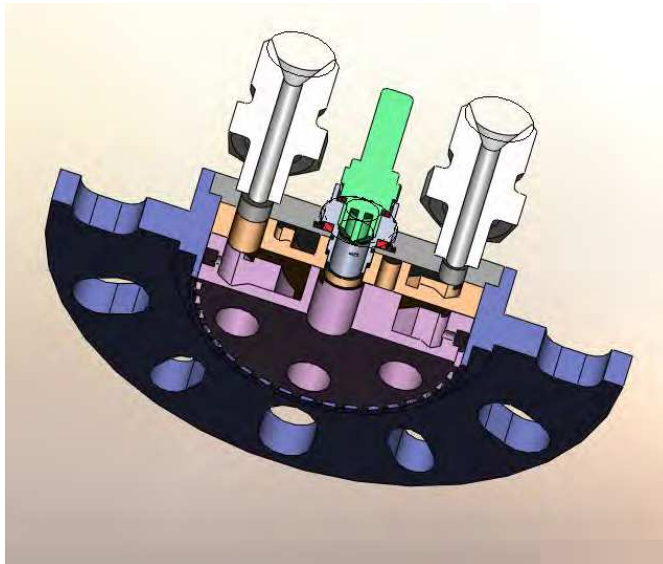

Fig. 11. Model of mixing head.



Fig. 12. Photography of mixing head.



Fig. 13. Plate of fuel. Red arrow - inlet of fluid.

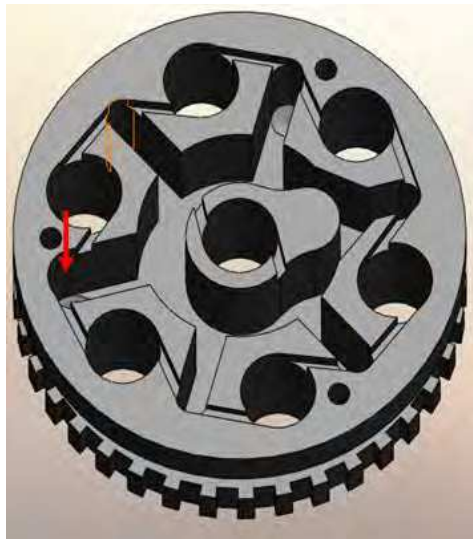

Fig. 14. Plate of oxidizer. Red arrow - inlet of gas.

Mixing head connect with combustion chamber across compressed copper ring. The fighting of bolts at flange is fulfilled with help of dynamometer key, in order to except unevenness compressed forces. Before fire tests the compressing of engine is fulfilled: combustion chamber in critical area is condensed by flange with central rubber cone. Flanges of head and condensed element are jammed by studs. During compressing the compression of connection chamber with mixing head and placement of candle are examined.

## 6. Investigation influence of polyisobutylene addition to kerosene at the combustion efficiency kerosene - oxygen propellant

Fire tests were fulfilled at the combustion chamber with short nozzle part (Fig. 15). That methodic of test lets to exam workability of own combustion chamber during long works without the use high expenditure vacuum equipment.

In process of experiment mass flow complex  $\beta_s = f_2(\dot{m}_\Sigma, k_m) = p_k F_c / m_\Sigma$  (or  $C^*$ ) of engine MAI-200-7OK is defined for 2 cases:

- standard kerosene;
- kerosene with 0.05% polyisobutylene addition.

The value of  $\varphi_{pk} = \beta_{theory} / \beta_{exp}$  show the efficiency of chamber process.

Main measured values were: stable combustion chamber pressure and mass flow of oxidizer and fuel.

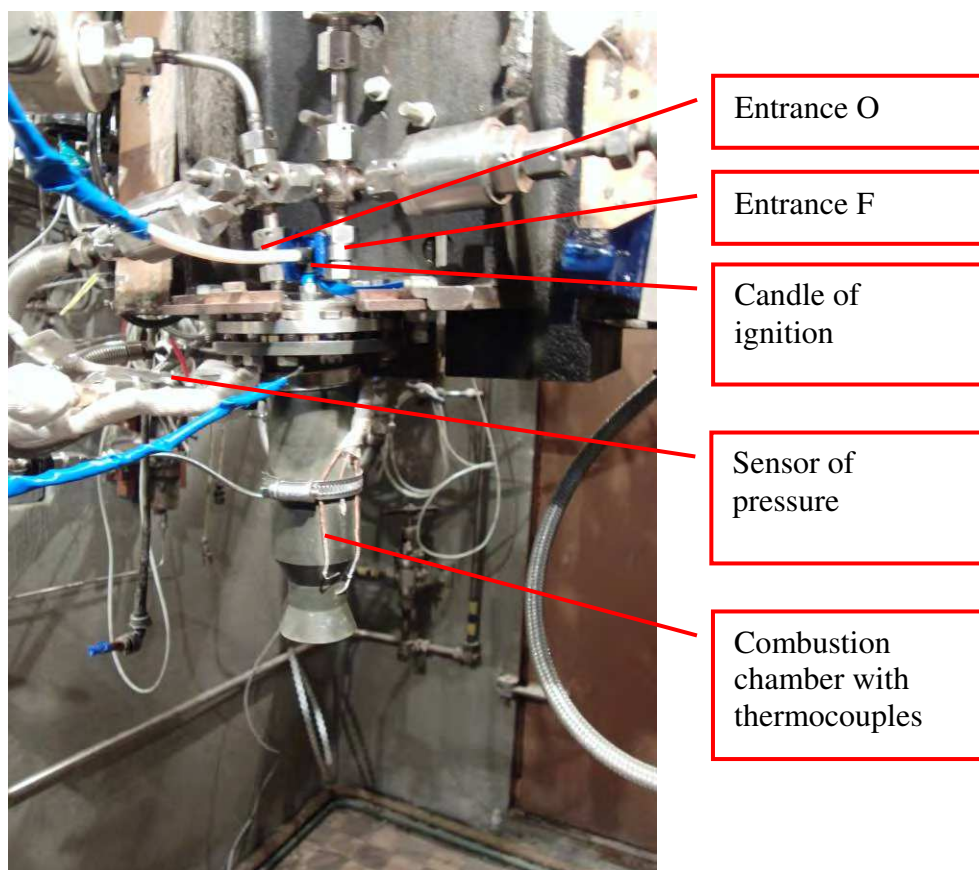

Fig. 15. Engine at the working zone of test bench.



Tests of engine are fulfilled in two stage:

- tuned tests (duration < 0.5 sec);
- pass tests (duration < 5 sec) (Fig. 16);

Results of pass tests are presented in Table 2.

Kerosene \ Parameter	$m_o, \text{ gr/s}$	$m_z, \text{ gr/s}$	$k_m$	$p_k, \text{ atm}$	$\beta^{\mathcal{D}}, \text{ sec}$	$\beta^T, \text{ sec}$	$\varphi_{pk}$
Without addition	24,3	5,7	4,2	4,09	148	172	0,86
With addition	26	6,8	3,8	4,14	146	169	0,86

Table 2. Base middle parameters of fire tests.



Fig. 16. Photo of working thruster.

In Fig. 17 - Fig. 20 presented the result of tests. The calculation of theoretical value of mass flow complex ( $C^*$ ) is fulfilled with help of program complex "Astra-M". The low value of mass flow complex ( $C^*$ ) because during test the combustion chamber pressure is 4.5 atm and less then nominal value of engine (10 atm). The difference in efficiency of chamber pressure depend on small diff of mass flow rate.

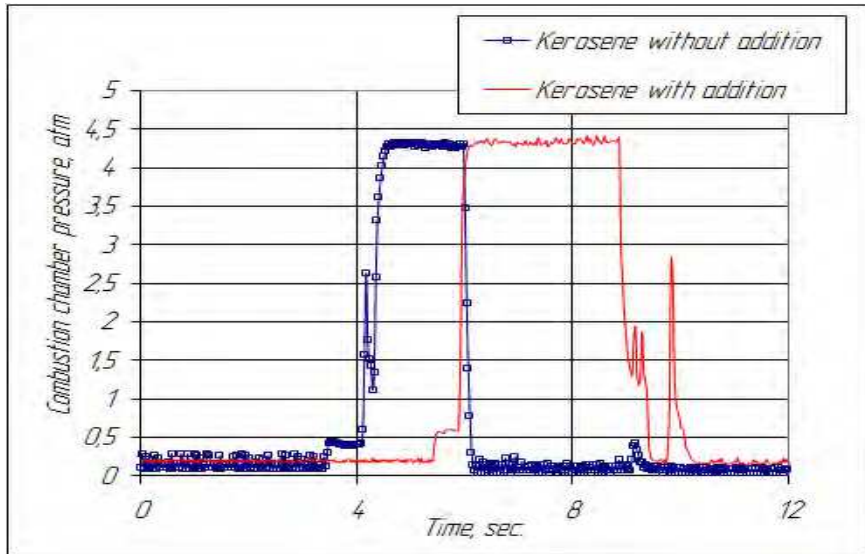

Fig. 17. Combustion chamber pressure.

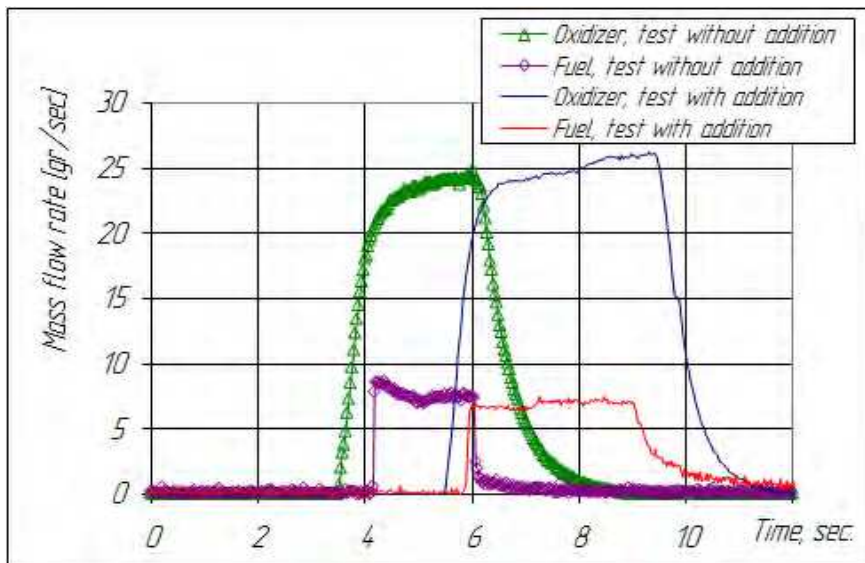
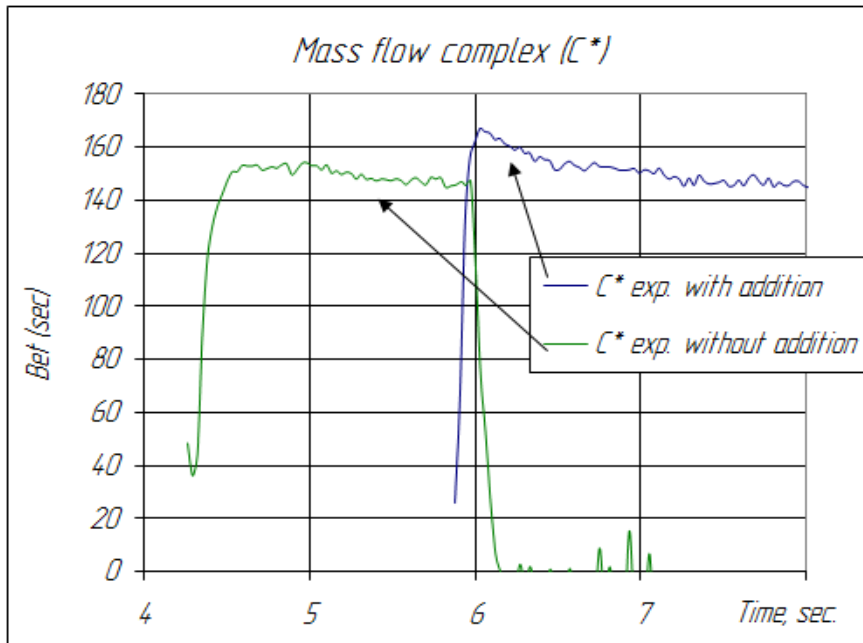
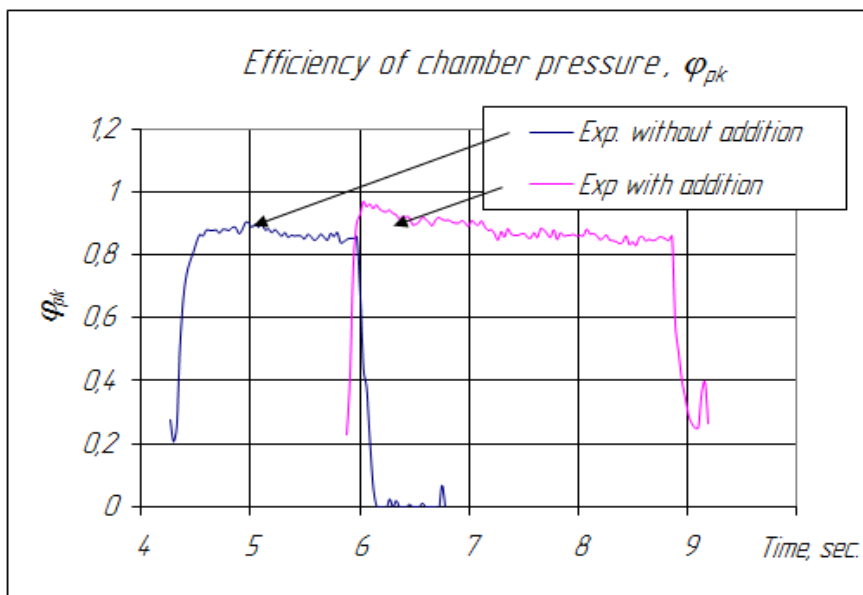

Fig. 18. Mass flow rate.

Fig. 19. Mass flow complex ( $C^*$ ).Fig. 20. Efficiency of chamber pressure  $\varphi_{pk}$ .



The result show that addition polyisobutylene to kerosene (0.05%) don't influence at combustion efficiency  $\varphi_{pk}$  of propellant in limit mistake of measurements.

## 7. Conclusion

Completed the initial investigation of the effect 0.05% addition polyisobutylene to kerosene at characteristics of pulverization and combustion efficiency of propellant kerosene + gaseous oxygen is fulfilled. Fire tests were fulfilled at liquid rocket engine of small thrust MAI-200-7OK.

Estimation quality of pulverization of swirl injector at value Sauter diameter was shown , that addition improved on smallness of pulverization. A small number of experiments and the difference in the initial parameters of the experiments cannot define exact dependency of polyisobutylene additions on the quality of the spray component. To determine the effect of polyisobutylene additions on the quality of the spray component is necessary to continue experimental work for a set of statistics.

A significant effect of additions of polyisobutylene on hydraulic resistance of the fine-mesh filter defined. Fine-meshed filter (mesh size 7mkm) gives a significant increase in hydraulic losses even on a small length of line of the stand. Without the filter pressure drop line decreased.

Effect of additions of polyisobutylene on the combustion effectively of the engine on experimental mode not detected. Firing tests will be continued on different modes to proof and get new results.

## 8. Referents

- [1] Alemasov V.E., Dregalin A.F., Tishin A.P. Teorija raketnyh dvigatelej. - M.: Mashinostroenie, 1989. - 464 p.
- [2] Vorob'ev A. G., Borovik I. N., Hohlov A. N. i dr. Modernizacija ispytatel'nogo ogneвого stenda dlja issledovanija rabochih processov v zhidkostnyh raketnyh dvigateljah malyh tjag na jekologicheski chistyh komponentah topliva. Vestnik MAI, T. 14, №1, 2010.
- [3] Kozlov A.A., Abashev V.M. Raschet i proektirovanie zhidkostnogoraketnogo dvigatelja maloj tjagi. - M.: MAI.2003. - 36 p.
- [4] Kozlov A.A., Borovik I.N., Vorob'ev A.G. Razrabotka programmy jeksperimental'nyh issledovanij rabocheго processa v kamere sgoranija ZhRD pri rabote na kerosine s polimernymi prisadkami poliizobutilena i provedenie pervogo jetapa jeksperimental'nyh issledovanij. Tehnicheskij otchet po Kontraktu № 30610 - 02020/ 980 - 09 - 187 mezhdru MAI i OAO NPO «Jenergomash» im. akademika V.P. Glushko (2 jetap). Moskva, 2009.
- [5] Kozlov A.A., Borovik I.N., Vorob'ev A.G. Tehnicheskij otchet po Kontraktu № 40440 - 02020/ 980 - 10 - 190 mezhdru MAI i OAO NPO «Jenergomash» im. akademika V.P. Glushko (3 jetap). Moskva, 2010.
- [6] Kudrjavcev V.M. Osnovy teorii i rascheta ZhRD. Moskva, «Vysshaja shkola», 1975.

- [7] Chvanov V.K., Fatuev I. Ju., Gaponov V.D., Sternin L. . Uluchshenie karakteristik raket-nositelej pri dobavlenii k toplivu vysokomolekuljarnyh prisadok. Dvigatel', № 6 (42), 2005.

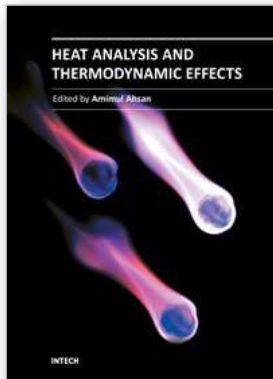

## Heat Analysis and Thermodynamic Effects

Edited by Dr. Amimul Ahsan

ISBN 978-953-307-585-3

Hard cover, 394 pages

**Publisher** InTech

**Published online** 22, September, 2011

**Published in print edition** September, 2011

The heat transfer and analysis on heat pipe and exchanger, and thermal stress are significant issues in a design of wide range of industrial processes and devices. This book includes 17 advanced and revised contributions, and it covers mainly (1) thermodynamic effects and thermal stress, (2) heat pipe and exchanger, (3) gas flow and oxidation, and (4) heat analysis. The first section introduces spontaneous heat flow, thermodynamic effect of groundwater, stress on vertical cylindrical vessel, transient temperature fields, principles of thermoelectric conversion, and transformer performances. The second section covers thermosyphon heat pipe, shell and tube heat exchangers, heat transfer in bundles of transversely-finned tubes, fired heaters for petroleum refineries, and heat exchangers of irreversible power cycles. The third section includes gas flow over a cylinder, gas-solid flow applications, oxidation exposure, effects of buoyancy, and application of energy and thermal performance index on energy efficiency. The fourth section presents integral transform and green function methods, micro capillary pumped loop, influence of polyisobutylene additions, synthesis of novel materials, and materials for electromagnetic launchers. The advanced ideas and information described here will be fruitful for the readers to find a sustainable solution in an industrialized society.

### How to reference

In order to correctly reference this scholarly work, feel free to copy and paste the following:

V.D. Gaponov, V.K. Chvanov, I.Y. Fatuev, I.N. Borovik, A.G. Vorobiev, A.A. Kozlov, I.A. Lepeshinsky, Istomin E.A. and Reshetnikov V.A (2011). The Investigation of Influence Polyisobutylene Additions to Kerosene at the Efficiency of Combustion, Heat Analysis and Thermodynamic Effects, Dr. Amimul Ahsan (Ed.), ISBN: 978-953-307-585-3, InTech, Available from: <http://www.intechopen.com/books/heat-analysis-and-thermodynamic-effects/the-investigation-of-influence-polyisobutylene-additions-to-kerosene-at-the-efficiency-of-combustion>

**INTECH**  
open science | open minds

### InTech Europe

University Campus STeP Ri  
Slavka Krautzeka 83/A  
51000 Rijeka, Croatia  
Phone: +385 (51) 770 447  
Fax: +385 (51) 686 166

### InTech China

Unit 405, Office Block, Hotel Equatorial Shanghai  
No.65, Yan An Road (West), Shanghai, 200040, China  
中国上海市延安西路65号上海国际贵都大饭店办公楼405单元  
Phone: +86-21-62489820  
Fax: +86-21-62489821



© 2011 The Author(s). Licensee IntechOpen. This chapter is distributed under the terms of the [Creative Commons Attribution-NonCommercial-ShareAlike-3.0 License](#), which permits use, distribution and reproduction for non-commercial purposes, provided the original is properly cited and derivative works building on this content are distributed under the same license.