

Development of Multi-Componential Decision Support System in Dynamically Changing Application Domain of Environment Protection

Dale Dzemydiene¹ and Saulius Maskeliunas²

¹*Mykolas Romeris University*

²*Vilnius University Institute of Mathematics and Informatics
Lithuania*

1. Introduction

The integrated, working on-line systems create the possibilities to combine the information from all the participating data warehouses and giving an opportunity to extract useful information by the use of available functions and tools. The systems designed for the dynamically changing domains in solving sustainable development problems are rather complex. The multi-componential, interoperable structure of decision support system is needed to develop for the purposes of applicable assistance in dynamically changing environment. The decision support system (DSS) requires additional means for knowledge representation and for management of the on-line working evaluation of ecological situation of the region and decision making processes in web environment.

The realization of the intellectual, working on-line decision support systems requires the developing of the innovative web portal infrastructure with embedded intellectual components (Leibowitz, Megholugne, 2003; Zavadskas, *et al.* 2007; Bolloju, 2002, Baltrenas *et al.*, 2008; Dzemydiene *et al.*, 2008). Web services will provide all types of information for users with different responsibilities. Novel work organization methods, knowledge systems, modern information - communication technologies are of great significance in supporting sustainable development management problems in web environment. Web portal infrastructure is constructed for managing, saving and receiving environmental information in different levels of participator's responsibilities.

The aims of this chapter concern:

- The methods to collect appropriate interface structures (components, scenarios) for services control;
- Recognize the concrete situation from data warehouses using broad spectrum of statistical and operative analysis methods;
- Use the distributed information systems and means of wireless communication systems (i.e. programming components, protocols, sensors and devices).
- The developing of decision support models which allow integration of the different pieces of data available into coherent framework for intelligence purposes with knowledge and decision making components.
- To recognize meaningful alternatives and strategies for prevention measures during the problem-solving process by means of knowledge- based analysis.

The sustainable development management and administration are organized by envisaging of very important problems for:

- Development of industrial potential aims are forwarded for reduction of expenses, improvement of working conditions, diminishing of risk, and implementing of new activity extension opportunities;
- Understanding the abilities for analysis of risk and arising threats;
- Backgrounds of legal regulation of unsustainable factors;
- Assessment of situation and planning strategies and their creation;
- Understanding scientific achievements and technological progress;
- Analysis of sustainable development indicators and connection with possibilities to define the regional situation in many aspects.

The chapter is devoted to problems of developing of the component-based architecture of the integrated decision support system that afford the monitoring situation and intellectual analysis.

The principles of environment protection consist of multiple components and make up a totality of requirements that can be presented as standards of enterprise functioning, requirements of healthy human environment, permission for functioning, taxes for cause pollution, etc. These principles give rise to very serious problem of legal regulation, the significance of which must be analyzed in multi-dimensional complexity and relations with all kinds of legal system. The current situation recognized on data management and reporting in the water sector resulted in the following findings. The water types have strong division between groundwater, marine water and fresh (surface) water. A lot of data are available at many different locations, in different types of databases, with a high degree of dedication and specialization.

The aims of this work are to show the possibilities to integrate the distributed data-bases of water management into web portal understanding the requirements of social and pragmatic interoperability, and using physical technological possibilities to describe e-services for public administration. We use data exchange standards of extensible mark-up language (XML), simple object access protocol (SOAP) messaging and hypertext transfer transport protocol (HTTP), Web Service Definition Language (WSDL), universal description discovery and integration (UDDI) registry for realization of the main interface components of water management portal realization.

The core of this on-line working system is the water resource management information system (WRMIS) that allows the access to the information distributed in different data warehouses and to recognize the situation on the surface water quality in rivers and lakes, ground water, and point sources (emissions). A detailed description of the main components of monitoring and decision making is given. The advantages of web service-based solution are presented by solving problems based on services offered by information systems while estimating proposals in what ways to simulate situations, to make and intellectualized environment pollution estimation by an object. For the improvement of information system structure and services research work is pursued.

2. Problems of recognition of boundaries for analysis of regional sustainable development management domain in DSS

Environmental protection problems are very important now, and a significance of their solutions will rise in near future. An ecological situation of a region may be considered as

rapidly changing environment. In this subject area we face the problem of representing process development dynamism and rapid information change. In addition, the process poses rather a complex inherent inner structure and mechanisms of interaction between subsystems that are frequently expressed by temporal, geographic, and space dependence conditions.

The complexity of structures of processes, multiple subsystems with their own complex mechanism interacting as internal or external parts, time and space/geographical dependencies, a great volume of data acquired from the processes, and multiple-criteria decision making are essential features for the analysis and representation of such an application domain.

The solutions of risk management must be solved in accordance with deeper organizational efforts of interstate, inter-departmental and interregional cooperation in a new way of understanding the complexity and possibilities of unsustainable development. The conception of sustainable development includes the way to match two different and sometimes contradictory attitudes as follows: "development - progress - growth" and "stability - security - environment". Brundtland Commission has brought forward this dilemma. They were the first who had defined the objective of sustainable development: *"Sustainable development is the process that meets present requirements without comprising the ability of future generations to meet their own needs"*.

Seeking to achieve sustainable development of the town, planners face with the underlying problems as follows:

- Municipalities don't possess land proprietarily rights;
- The majority of cities haven't prepared any strategic or general plans for town development that correspond to the conditions of market economy as well as the principles of sustainable development;
- New territories are being reclaimed for constructions, while social, technical and communicational infrastructure stay behind hopelessly;
- The majority of construction objects are being built within a very long time and this necessarily cause the high price for buildings;
- The work quality of city passenger transport is getting worse.

The general objective of sustainable development is to protect and improve quality of life. Therefore, both preventives need new innovative management methods which have a global influence on sustainability. People, however, appreciate many moments of environment that are not related with physical part of environment such as aesthetics, cultural environment, rural areas attainability and quietness as well. Again, inhabitants are concerned about very material things that are not environment at all. Material standards of living, social health and security, education opportunity, public health care, completeness of life, personal career possibilities, self-expression, community, culture, social life, recreation - all these things are treated as a part of quality of life.

To comprehend globalization phenomena, problems of economic development, trends of information and other technologies evolution, as well as the problems of animate nature, coordination of actions, social security and law are of the most significant trends for progressive development of regions (countries) under development. The social understanding of interoperability concerns intentions, responsibilities and consequences behind the expressed statements and commitments shared as results.

This research study is aimed to analyze activities of enterprises, institutions, and organizations according to some components of sustainable requirements dealing with the ecological sustainability, cleaner goods manufacturing, and economic growth.

The water management and water quality treatment is one of important problems related with environment protection, survival of variety of biological life cycles, and implies many requirements for sustainable management (Baltic 21 2003; Swanson *et al.* 2004, Dzemydiene *et al.* 2008).

The current situation recognized on data management and reporting in the water sector resulted: (1) Having different treatments of water types [groundwater, marine water, surface water, and others]; (2) A lot of data are available at many different locations, in different types of databases; (3) The amount of data to be stored and analyzed will dramatically increase in near future.

This carries out some difficulties to share data: no strong tradition for coordination and sharing of data and knowledge. The rising needs of water resources influence the sewage quality management issues.

In the light of these attitudes of sustainable development, researchers have raised the purpose to determine the possibilities of cities' development, at the same time evaluating various factors that influence the extents of investments in different towns for cleaner environment.

The activity of large enterprises, institutions, and organizations should be based on versatile responsibility of enterprises and stimulation of efficiency, paying ever more attention to the requirements of sustainable development and to the issues of environment protection: strategic and tactical planning and control, estimation of economic- social balance, application of information technologies and constant check systems, as well as to legal regulation effect.

Decision support is also related with the problems of estimation of general ecological situation of the given region, the indices of pollution provided in the project, the risk factors related to preservation of links that are of biological significance and time dependent, etc.

3. General solutions of component-based decision making system development

An approach integrates problem solving and model-based knowledge acquisition within an extensive model of different knowledge types, describing a changing information environment and decision-making processes in a DSS (Fig. 1). Some exceptional features of the changing environment, especially dynamic components, require additional means for knowledge representation, data verification and assurance of efficiently making decision processes.

An approach to modelling of problem solving expertise has been developed, based on the four layers of expert knowledge: (1) the domain layer contains definitional knowledge of the domain; (2) the inference layer describes the structure of reasoning and inference mechanisms that operate upon domain layer; (3) the task layer explicates knowledge about when a certain inference is to be made; (4) the strategic layer sets up the plan for achieving a goal, thereby controlling the reasoning in the task layer.

The expertise is knowledge in broadest interpretation of the term and includes factual knowledge of domain, problem solving strategies and methods, and learning strategies. Some components of the expertise model are distinguished in our decision support system as well: the fundamental knowledge that describes the application domain in static (semantic model of information structure) and dynamic (the imitational model of tasks and processes) perspective; the model of the problem solution strategy control level (e.g., plans,

diagnostic, strategies of correcting task fulfilment); the reasoning model that embraces stepwise decision support structure.

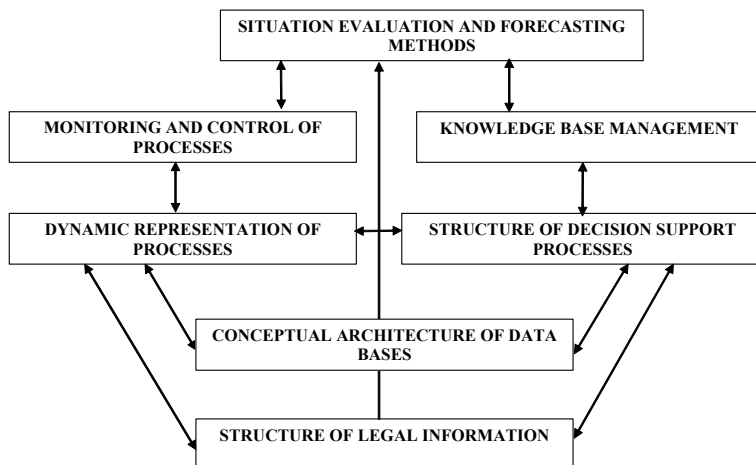

Fig. 1. General schema of the components of decision making system

The described decision support system helps in analyzing development processes of enterprises in accordance with water evaluation. We suggest that the means should be based on responsibility of enterprises and stimulation of efficiency, paying even more attention to the requirements of sustainable development.

The multiple objective decision support level deals with the analysis of information obtained from the all measurement points revealed in the dynamic sub-model of DSS.

The modelled system is regarded as direct mapping of real enterprise system and decisions can be based on decisive facts and follows rather deterministic rules.

Rapidly changing environment may include additional techniques for planning, operation control and decision support.

A new viewpoint and approaches are needed allowing us to concentrate the attention on the organizational aspects that ensure information for decision support. The technology for building such systems must provide methods for acquisition, structural representation of many types of knowledge taking into consideration the large, shared and distributed databases.

We understand the interoperability as “the capability to communicate, execute programs, or transfer data among various functional units in a manner that requires the user to have little or no knowledge of the unique characteristics of those units” by recommendations of ISO 2382-01.01.47. Interoperability can be examined in different aspects of understanding of its framework, concerning physical, empirical, syntactical, semantic, pragmatic, and social layers.

The interoperability problems of distributed databases are important in the developing of the operatively working web services aimed for all sectors of managing. The following web services are designed for solving of tasks in water resource management and contamination evaluation sector with due attention to the international environment protection context.

The examples of development multi-componential decision support system are demonstrated on research investigations according to the requirements of European Union (EU) Water Framework Directive, Sustainable development Directives and EIONET ReportNet infrastructure. The main components of decision support system are analyzed by using different knowledge modelling and web service development techniques. The structure of water resource management information system (WRMIS) becomes the core of the decision support system in which web services are realized. The main components for evaluation of processes of contamination and water monitoring are represented by data warehouse structures.

The solutions to satisfy the interoperability requirements are demonstrated by architectural design of the system by integrating the distributed data warehouses and geographical information system means. The web services are based on common portal technology. The organizational and political arrangements require deeper and stronger participation activities by all members in reporting and understanding the importance of sustainable development problems and risk evaluation possibilities.

4. The architecture of component-based decision making system for evaluation of water contamination processes

The core of our decision support system and portal web service realizations is the information system – WRMS that realizes main interoperable functions of distributed information systems of water data storage. This water resource management information system (WRMIS) is developed under the project "Transposition of the EU Water Framework Directive in Lithuania" (Carl Bro as and AAPC 2003). The EU Water Framework Directive (Directive 2000/60/EC) and the future European environmental data reports repository ReportNet (Saarenmaa 2002) imply.

4.1 The constructions of the core system

Main principles of water resource management information system development: (1) a holistic approach, requiring integration of data and knowledge from different institutions and regions; (2) high data storing, analysis and reporting requirements; (3) assured interoperability based on XML Web Services, SOAP, HTTP protocols; (4) requirements for reporting in a format of GIS maps.

On the other hand, the detailed guidelines and software tools of ReportNet for Water sector data have not yet been finalized.

A focus area for the WRMIS prototype is to facilitate easy dataflow between the institutions and give access to data for relevant institutions and the public.

Most of the existing environmental information systems have evolved during a long period of time. Also, they stem from different traditions. Therefore most of the systems are found to be both heterogeneous and scattered - without much possibility of using data and information in an integrated manner. In the years to come it will be a necessity to combine data from many sources to better understand the environmental processes and to be able to make the required reporting. It is possible to overcome these barriers by creating an environmental portal.

Also it has been cleared up that the main general challenges to be met in developing such an environmental portal are as follows: (1) Ownership of data; (2) Telecommunication/Digital infrastructure (allowing sufficient Internet throughput); (3) Maintenance and development

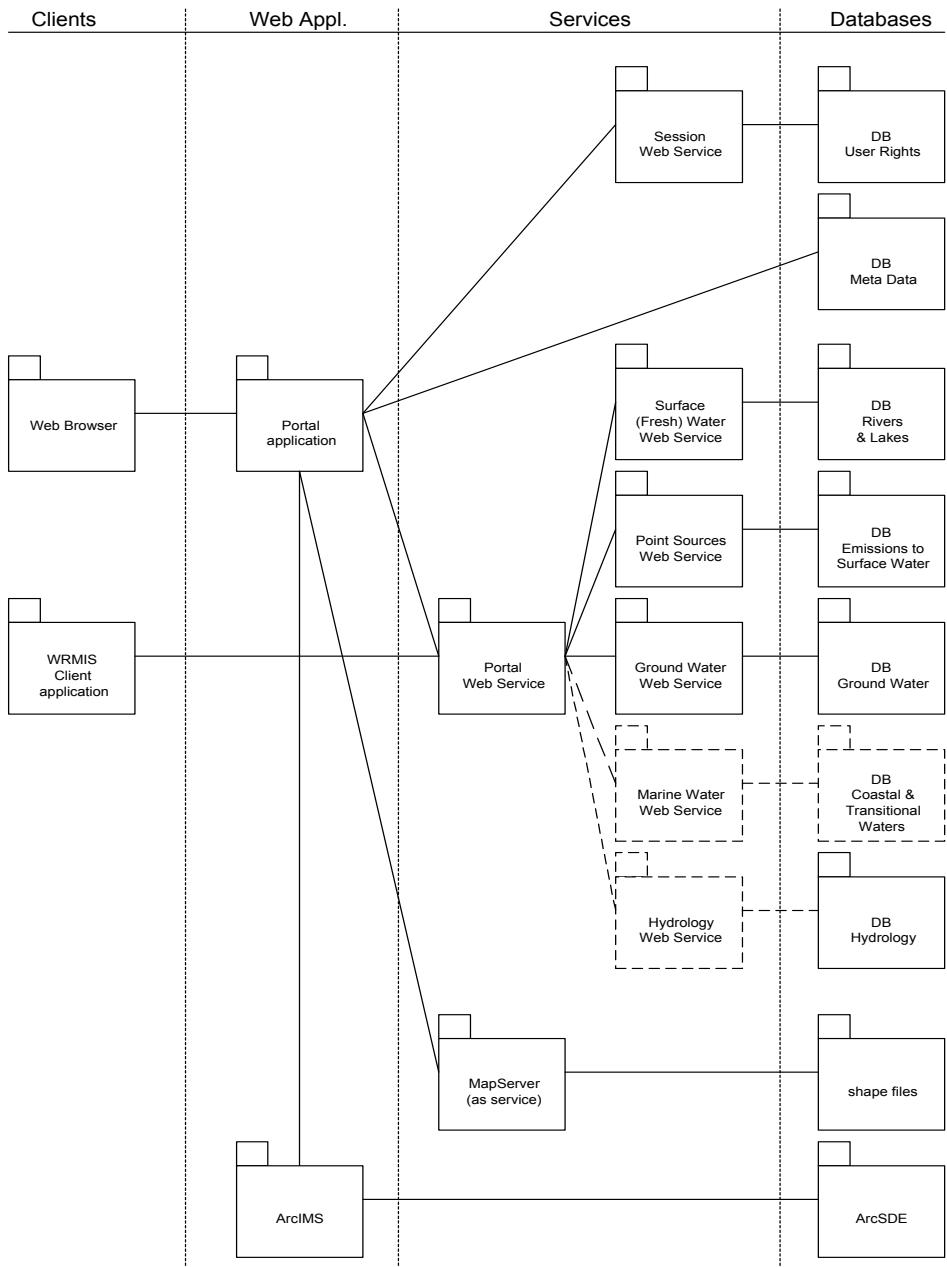

Fig. 2. The structure of interconnections of packages of the water resource management information system

(i.e., involvement of more institutions, regional departments of the Ministry of environment; integration with external data warehouses and Web Services - for reporting the EU, etc.): institutional setup, manpower; (4) Openness and a proper public participation.

The various types of data providers to the system require that some special software should be available for them. It can be achieved by implementing a Client/Server system based on services at the participating data warehouses.

The scheme of relationships between main components of the water resource management information system prototype, corresponding to the mentioned requirements of technical interoperability is presented in Fig. 2.

The databases and allocated tools have to be secured by restricted access.

A distributed database system, based on data warehouses (DW) and web services, was chosen because it improves both the quality of data and the value of the reports. It allows us to eliminate some of the boring and time consuming work associated with collection of data from different sources and bringing it on a format so that could be used in the common context. In addition, it has been decided that the system should be independent of which type of database provider is selected.

This is the case where the following tools are used: 4th-generation-language development environment suitable for a Rapid Application Development; the whole access to the databases should be performed by use of SQL; XML and its technologies should be used for data exchange and presentation.

Continually we have had evaluate the situation according to the sustainability in the given region. For this purposes we deal with the decision support, integrating main components for evaluation of environment contamination processes (Dzemydiene *et al.* 2008).

Decision-making aimed to on-line evaluation of the pollution processes of an enterprise deals with: the complexity of structures of processes; multiple subsystems with complex mechanism interacting of internal or external parts; time and space/geographical dependencies; great volume of data acquired from the processes; multi-criteria decision - making; causal, temporal relationships and interaction of processes.

4.2 Knowledge - based description of processes for contamination evaluation

The main purpose of the advisory system is to assist in environment protection control processes, creating of suspect profiles by giving computer-aided instructions, planning and situation recognition techniques. Use of advisory systems may also improve legal training, for example, providing environment protection agencies with advice on the type of information required by inspection to reduce the pollution activities. As an example, we consider the activities of enterprises, firms, and organizations, i.e. the main stationary objects, to estimate pollution of water bodies. In line with the object functioning nature the project reflects information on the activities pursued while the license defines the limit in which environment pollution is allowed, i.e. limits of pollutants cast are drawn. Besides, the objects must give reports according to their activities pursued and in line with statistical account ability forms.

The level of representation of dynamical aspects shows the dynamics of observable processes. The multiple objective decision making deals with the analysis of information obtained from the static sub-model taking into account all possible measurement points revealed in dynamic sub-model of such a system. Further actions, operations, etc. are determined through the mechanism of cooperation of agents that are working by using the temporal information registration window.

The complexity of environment research problems consists in the complexity of criteria and differences of attitudes.

The knowledge representation framework supports organizational principles of information in a static semantic model. The model of behavioral analysis of the target system shows the dynamics of observable processes. One of its characteristics is a need for a lot of data to properly model and verify these problems.

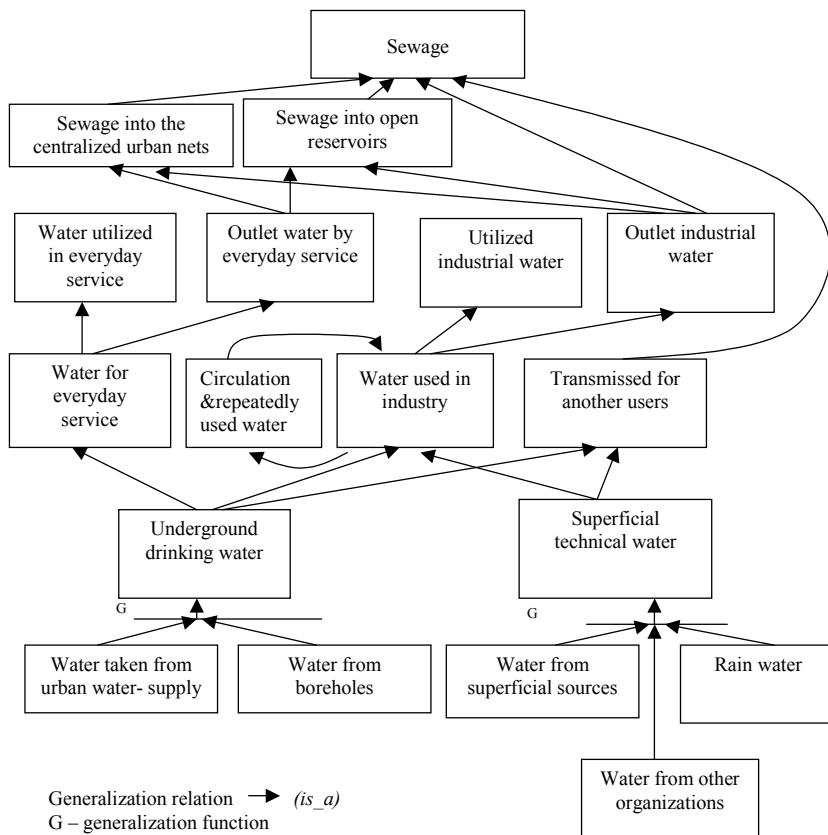

Fig. 3. An example of semantic representation of water distribution in a contamination object

Let X_{ext} denote the extension of a concept X_{con} with respect to its extensionality and X_{int} denote the extension of a concept X_{con} with respect to its intentionality. Then, the definition $(\forall x/X_{ext})(\exists pp/X_{int})(\forall p/pp)p(x)$ is the intentional representation of a concept X_{con} .

Three types of abstractions of relationships between chosen concepts are used in constructing a semantic model: generalization, decomposition (aggregation), and transformation.

Generalization abstraction defines the type of intention "concept - concept": $E_j IS_A E_i$, where another generalizes one concept is defined by the set of another concepts.

Aggregation (decomposition) abstraction helps us to construct concept by others concepts depending on their decomposition or functional dependence: $E_i \text{ PART_OF } E_j$

Transformation is very similar to that of the aggregation, except that it contains a calculation rule, which specifies how the values representing the occurrences of the defined concept are derived from the values representing the defining concepts.

More in details we consider the example of analysis of water resources and the pollution of sewage of the enterprise. The pollutants from the production are entering into the water in some types of cases (Fig. 3). The initial task is always data gathering, resulting in a set of observed findings.

A dynamically changing environment imposes time constraints. Many problems are to be solved simultaneously. The values of the observed parameters may change dynamically, depending on time and the events occurring. Solution of different problems is interfered with one another. For instance, the high concentration of harmful material thrown out into the air is related with the risk factors referring prevention of links that are of biological significance and time-dependent, etc. Another essential aspect of such an application domain is its spatial dimension. While in many other application domains the problems of study are within a very precise and, usually, narrow frameworks. For instance, the contamination problem of an enterprise (e.g. manufactory, firm, and plant) deals with spatially varying phenomena of unbounded limits.

4.3 Formal representation of processes by E-nets

The E-nets (Evaluation nets) are the extension of Petri nets, and were introduced by (Noe, Nutt 1973). The structure and behavioural logic of E-nets give new features in conceptual modelling and imitation of domain processes and decision-making processes (Dzemydiene, 2001).

Apart from time evaluation property, E-nets have a much more complex mechanism for description of transition work, some types of the basic transition structures, a detailing of various operations with token parameters. In addition to Petri nets, two different types of locations are introduced (peripheral and resolution locations).

The exceptional feature is the fact that the E-net transition can represent a sequence of smaller operations with transition parameters connected with the processes.

It is possible to consider the E-net as a relation on (E, M_0, Ξ, Q, Ψ) , where E is a connected set of locations over a set of permissible transition schemes, E is denoted by a four-tuple: $E=(L, P, R, A)$, where L is a set of locations, P is the set of peripheral locations, R is a set of resolution locations, A is a finite, non-empty set of transition declarations; M_0 is an initial marking of a net by tokens; $\Xi=\{\xi_j\}$ is a set of token parameters; Q is a set of transition procedures; Ψ is a set of procedures of resolution locations.

The E-net transition is denoted as $a_i=(s_i, t(a_i), q_i)$, where s_i is a transition scheme, $t(a_i)$ is a transition time and q_i is a transition procedure.

The input locations L_i' of the transition correspond to the pre-conditions of the activity (represented by the transition in Fig. 4). The output locations L_i'' correspond to post-conditions of the activity.

In order to represent the dynamic aspects of complex processes and their control in changing environment it is impossible to restrict ourselves on the using only one temporal parameter $t(a_i)$ which describes the delaying of the activity, i.e. the duration of transition.

The complex rules of transition firing are specified in the procedures of resolution locations Ψ and express the rules of process determination.

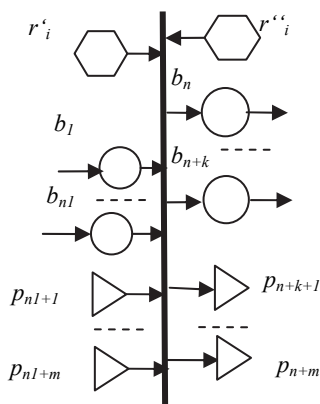

Fig. 4. The common transition schema of E-net representation

A concrete parameter of token obtain a concrete value according to it's identification, when the token is introduced into the location $b_l(\xi_k)$. Such a combination of locations with the tokens in them, the parameters of which obtain concrete values, describes a situation for process execution.

Such an understanding of the transition procedure enables us to introduce the time aspects into procedure of control of processes and determine operations with token parameters in time dimension.

The exceptional feature is the fact that the E-net transition can represent a sequence of smaller operations with transition parameters connected with the event/process. Operations are described in the transition procedure with these parameters $\Xi = \{\xi_j\}$.

The E-nets support a top down design in graphical representation manner. The hierarchical construction of dynamic model is simplified by representing macro-transition and macro-location constructions.

The goal of the manufacture enterprises is to rationally develop an ecologically clean production. It means that enterprises (e.g. factories, plants, etc.) must guarantee the manufacture of products with minimal pollution of the environment and damage to nature, not exceeding the permissible standards.

Thus we have a problem of two objectives/goals:

G_1 - increase in capacity of production and profits of the enterprise under consideration;

G_2 - decrease in environmental pollution within the permissible limits.

The first criterion \tilde{N} - the profit of production has to be maximized while the second criterion \tilde{O} - the environmental pollution has to be minimized. The importance of the first criterion is determined by various economic industrial parameters. The maximization of its importance is of direct interest to and care of the producers. The main task of our decision support system is to maintain the importance of the second criterion \tilde{O} within the permissible limits and thus act on the first criterion. The \tilde{O} criterion is stipulated by three factors: water pollution, air pollution and contamination of harmful solid wastes: $\tilde{O} = \{W, A, H\}$.

More in details we consider the example of the analysis of water resources and the pollution of sewage of the enterprise. The pollutants from the production are entering into the water in some types of cases. Such cases we find out by the construction of E-net distribution processes of sewage in the enterprise (Fig. 5).

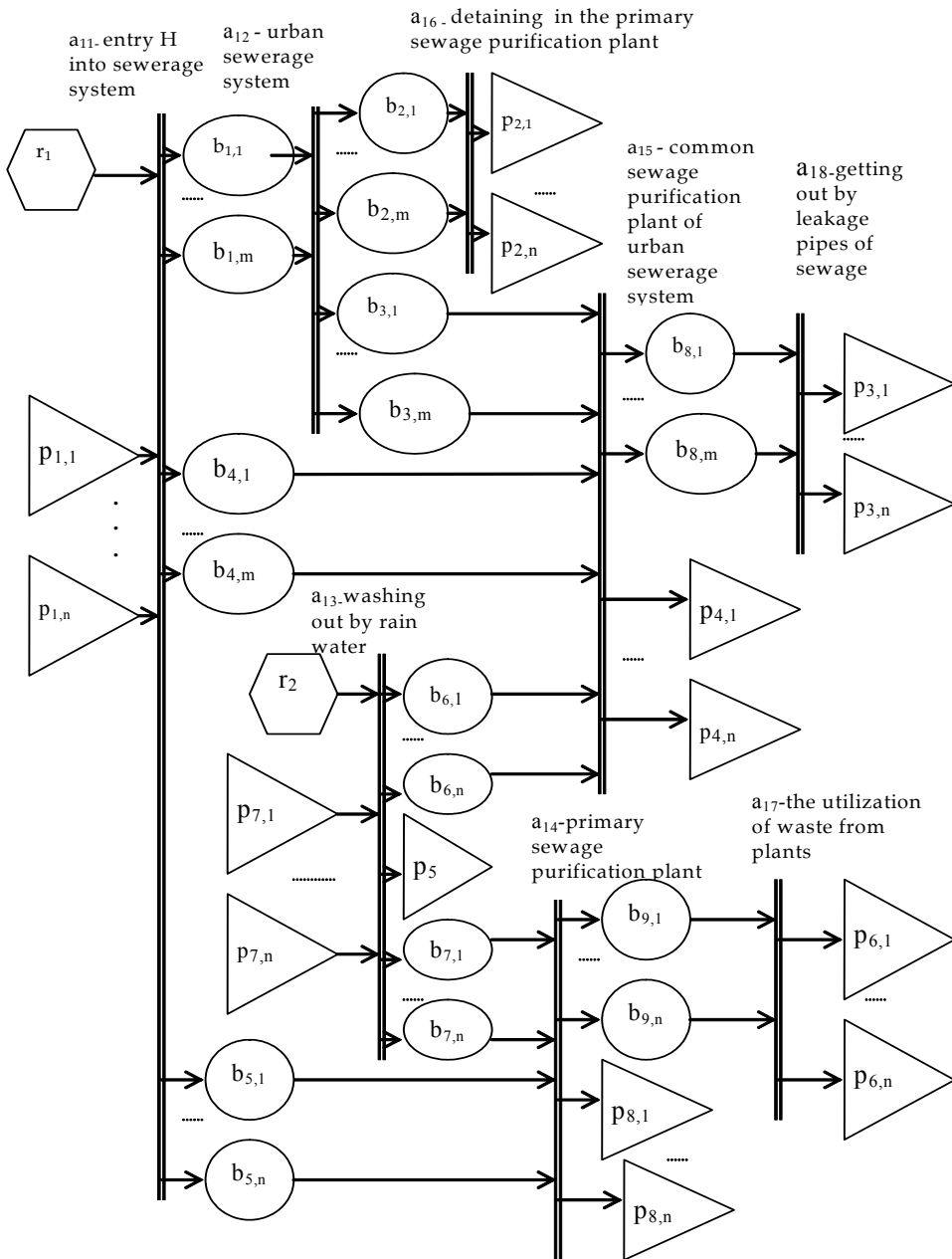

Fig. 5. The E-net of distribution processes of harmful materials in the water of enterprise
 The harmful materials that are represented by peripheral locations of the E-net (Fig. 5) are very important for evaluation of water pollution of an enterprise:

$p_{1,1}, \dots, p_{1n}$ are materials included in water efflux;
 $p_{2,1}, \dots, p_{2,n}$ are waste materials from the primary sewage purification plant;
 $p_{3,1}, \dots, p_{3,n}$ are waste materials from the common sewage purification plant;
 $p_{4,1}, \dots, p_{4,n}$ are materials entering into open reservoirs, that are not detained in the sewerage system of the enterprise;
 $p_{5,1}, \dots, p_{5,n}$ are materials entering into open reservoirs, if there is no rainwater collection system;
 $p_{6,1}, \dots, p_{6,n}$ are utilized wastes from primary purification plants;
 $p_{7,1}, \dots, p_{7,n}$ are materials entering into rain water if they are stored openly in the territory of enterprise;
 $p_{8,1}, \dots, p_{8,n}$ are materials entering into the external reservoir from the primary sewage purification plant.

The E-net structure, which describes the decision-making process, gives visually the parameters needed for control and the control structure relation with tasks and decisions.

5. Web portal structure for water management by requirements of interoperability of information systems

The portal has been developed as a web portal where the users can receive information related with WRMIS according to the water framework directive (WFD). It combines data from the participating data warehouses (DWs) and gives the users an opportunity to extract useful information by use of the functions and tools available.

The portal has been developed by use of Active Server Pages (ASP - server-side script engine for dynamically-generated web pages), and it communicates with the DWs by use of SOAP/XML (see an example of ASP code for generating SOAP calls in Fig. 6).

```
Dim xmlDocRoot, xmlDocChildren
Set XMLClient = Server.CreateObject("MSXML2.ServerXMLHTTP")
SoapText=SOAPCallBegin+"<SOAPSDK1:GetSites xmlns:SOAPSDK1=""urn:SfinxIntf-ISfinx"">"+_
    "<ASessionId>" + CINETSessionID + "</ASessionId>" + _
    "<ARegionNo>" + ARegionNo + "</ARegionNo>" + _
    "<ASiteId>" + ASiteNr + "</ASiteId>" + _
    "<AStartDate>" + "1995-12-30" + "</AStartDate>" + _
    "</SOAPSDK1:GetSites" + SOAPCallEnd
SoapServer = SOAPServerURL
Call XMLClient.open("POST",SoapServer,"False")
Call XMLClient.setRequestHeader("Man", "POST"+" "+SoapServer+" HTTP/1.1")
Call XMLClient.setRequestHeader("MessageType", "CALL")
Call XMLClient.setRequestHeader("Content-Type", "text/xml")
Call XMLClient.send(SoapText)
Set ObjXML = XMLClient.responseXML
Set xmlDocRoot = ObjXML.documentElement
Set xmlDocChildren = xmlDocRoot.childNodes
Set xmlDoc = Server.CreateObject("Microsoft.XMLDOM")
xmlDoc.Load(ObjXML)
Set objXSL = Server.CreateObject("Microsoft.XMLDOM")
objXSL.async = false
styleSheet = StylesheetDir & "\siteinfo.xsl"
objXSL.load(styleSheet)
```

Fig. 6. Example of SOAP call to "getSites" by use of ASP

The portal gives access to information on: surface water quality, ground water, and point sources (emissions).

The portal includes services where the users can have useful information related to the WFD and the WRMIS, including links, documents, and news.

A login procedure has been established on the WRMIS portal to secure that only registered users can have access to the available information. The WRMIS system administrator has special rights to the system, that give access to maintain the system by updating the news, links, documents, meta database, and the system administrator is responsible for granting rights to the users of the system. The list of portal Web Service operations is presented in Table 1.

Operation	Description
ListOfRegions	Returns a list of region IDs and names
ListOfSites	Returns a list of site IDs and names
GetSiteInfo	Returns site information, such as name, coordinates, distance to river mouth, etc.
GetSamples	Returns a list of sample dates for the specific site
GetAnnualMeans	Returns annual means for a specific monitoring site in a specific period
GetAnalysisResults	Returns raw data for a specific monitoring site and period
ListOfPS	Returns list of point sources
GetPSInfo	Returns main information for a specific point source
GetPSOutlets	Returns raw data for a specific point source and period

Table 1. The main operations of web services of the developing portal

The UDDI registry of WRMIS Web Services is developed for internal purposes, having in mind that exposing it freely on the Internet increases the security risks (Data Junction 2003).

5.1 Surface water database (DW1)

A data warehouse has been established based on data from the "Water monitoring in rivers and lakes (VANMON)" database. Database structures similar to the VANMON database have been created in Oracle, and an interface by use of a database SOAP server has been established on top of the database. The database server provides SOAP-based Web Services with basic functions for using and maintaining the database, e.g.: selection from, update of, and appending to the WRMIS VANMON database.

By connecting to the WRMIS portal and selecting a Surface Water item in the menu, the user is able to retrieve data from a specific river monitoring station. User has a possibility to select a site and get all the analysis results stored in a table form, and to save the retrieved data as an Excel spreadsheet.

The dropdown box with regions is the result of a SOAP call to the Surface water data warehouse. When the user selects a region in the dropdown box, or when the user clicks on a region in the map, a new map and an additional drop down box with sites appears. This map can be zoomed to the selected region. In the map the site and river layers are visible, and the site layer is click-able.

The surface water Web Service has the next operations: Init, Meta Tables, Meta Fields, Reload Meta Data, Add To Table, Delete From Table, Update In Table, Select From Table, Select From Table(2), Joined Select, Replace Lookup Select, Union Select, and Get Object.

5.2 DW1 client application

For the WRMIS VANMON database a special client application has been developed, that enables the users to update the central WRMIS VANMON database by use of the Internet. The application makes it possible for the staffs both in the Regional departments and in offices of EPD to work with the common data.

The application can be downloaded from the WRMIS portal and installed on a local PC. The use of this application is managed by the WRMIS VANMON database administrator, who grants user rights to all users.

The client application, the portal SOAP server, and the database SOAP servers have all been developed by use of Delphi. The server applications run on the Internet Information Server, while the client application can run in a Windows environment on the local PCs.

5.3 Point source database (DW2)

A second data warehouse similar to the surface water data warehouse was established on top of the point source (emissions) database. The system gives access to information on outlets from point sources. The database was made up by redesigning and integrating separate annual FoxPro databases into one common database.

The functionality of the Point Source database and the corresponding Web Service is rather similar to that of the Surface Water database.

5.4. Ground water database (DW3)

The third data warehouse has been found in the Geological Survey of Lithuania (GS). The WRMIS staff in GS has elaborated this data warehouse in the Java environment. Web Services that give access to information stored in the GS Oracle Ground water database have been developed and made available on the Internet.

The technology used: (1) Programming language [lgt.* classes]; Java JSDK 1.4 API; (2) SOAP server [SOAP Servlet], Apache SOAP v2.3.1; (3) Servlet Container [Web server], Apache Tomcat 4.04; (4) Database [geological dataset], Oracle8 Enterprise Edition Release 8.0.6.2.0; (5) Link to Database, Oracle JDBC Thin JDBC Driver; (6) Server Operating System, SunOS 5.8 [Solaris 8] Generic_108528-17 sun4u sparc SUNW, UltraAX-i2; (7) Server Platform [hardware], Sun Fire V120 Server, 650 MHz UltraSPARC-IIi.

The WRMIS prototype has a wide use of digital maps in the GUI both for presentation and administration purposes. All digital maps are stored either in ArcSDE, or in shape files. The system uses maps for selecting data. Two map servers have been developed, making it possible for the users to receive information in a map and to compose their own maps on request. The first solution has been developed by means of the MapServer (hosted in EPA) and shape files.

The MapServer is an open source development environment¹; MapServer functionality is easy to integrate in Internet-based GIS applications. Another solution has been achieved by use of ArcIMS and ArcSDE (hosted in the Ministry of Environment).

A meta-database with information on the digital maps used in the Map tools has been formed. The meta-database holds information described as mandatory in the ISO 19115 standard².

¹ <http://mapserver.gis.umn.edu/>

² <http://www.isotc211.org/scope.htm#19115> , <http://www.isotc211.org/publications.htm>

The system is ready for data interchange with external Web Services. Also, the system can be easily improved to share information on digital maps with external systems by implementing, using and supporting the OpenGIS Web Map Server (WMS) and Web Feature Service (WFS). Both Mapserver and ArcIMS can be configured to support WMS.

A large amount of measurement points at different time and conditions causing overlapping and conflict between different observations, and the inaccuracy of measurements and reports.

6. Conclusions

Consequently, intelligence programs have been developed, leading to recognition of a field of activity called contamination analysis, which has been described as the identification of and the provision of insight into the relationship between environment data and other potentially relevant data with the view to specialist experts. A key part of this approach enforcement is to understand those activities, through the development and use of methods, models and tools for collecting and then interpreting the large volume of data available in real time for environment protection investigation. Some issues for qualitative information representation including statistical analysis are considered.

The water resource management information system proves that it is possible to establish a Web portal that provides the users with information, on request, in a system based on decentralised data sources. This project has also proved that it is possible to integrate information from different institutions, based on different technology, into a common information system by means of the Internet, XML and Web Service technologies, and by bridging to the well known existing systems.

The WRMIS system architecture is designed both to serve a centralised and a decentralised solution. It is therefore possible to configure a system so that the database servers were placed at different geographical locations as well as at the same place. A centralized solution with all the servers placed in one centre can be maintained by a highly skilled staff that can both maintain the hardware, and the software. Such a centre ought to have powerful equipment and Internet connections and the uptime for services should be close to 100%. The disadvantages are that data, in many cases, are at the hands of people that have none or but little knowledge on the use of data. There is therefore some risk that the staffs have vague motivations for the system performance and further development.

Another solution can be based on decentralized data warehouses, where different topic centers are responsible for the maintenance of their own data warehouse. This requires for competent manpower able to have the servers running as well as to administrate and maintain the software and databases at each data warehouse.

7. Acknowledgment

We would like to acknowledge the developers from Denmark and especially engineer Kim Jacobsen from Carl Bro regarding the possibilities to participate in the processes of preparing the project "Transposition of the EU Water Framework Directive in Lithuania" and realization of water resource management information system (WRMIS), and Ministry of Environment of the Republic of Lithuania.

8. References

- Analysis of Summary of Results of Environment Protection Control. 2006. Data of State Environment Protection Inspection. <http://vaai.am.lt/VI/index.php#a/458>
- Baltic 21, 2003, Report 2000-2002: Towards Sustainable Development in the Baltic Sea Region. Baltic 21. Series No. 1. Poland, Drukarnia. MISIURO.
- Baltrėnas, P.; Morkūnienė, J.; Vaitiekūnas P. (2008). Mathematical Simulation of Solid Particle Dispersion in the Air of Vilnius City, *Journal of Environment Engineering and Landscape Management* 16(1): 15-22.
- Brown, A.; Johnston, S.; Kelly, K. (2002). Using Service-Oriented Architecture and Component-Based Development to Build Web Service Applications. IBM Rational Software White Paper, <http://www.rational.com/media/whitepapers/TP031.pdf>
- Carl Bro as and AAPC, 2003. Transposition of the EU Water Framework Directive and Elaboration of a National Strategy for the Management of Water Resources in Lithuania. Project of DANCEE (Danish Co-operation for the Environment in Eastern Europe) programme, <http://gis.am.lt/wfd/>
- Data Junction. (2002). Web Services: The New Generation of Application Integration. White Paper. <http://www.datajunction.com>
- Directive 2000/60/EC of the European Parliament and of the Council establishing a framework for the Community action in the field of water policy. *Official Journal, OJ L 327*, 22 December 2000. Available from http://europa.eu.int/comm/environment/water/water-Framework/index_en.html
- Dzemydiene D. (2001). Temporal Information Management and Decision Support for Predictive Control of Environment Contamination Processes. In J. Eder, A. Caplinskas (Eds.) *Advances in Databases and Information Systems. Proc. of Fifth East-European Conference*. Vilnius, p. 158-172.
- Dzemydiene D. 2001. An Approach to Modelling Expertise in the Environment Pollution Evaluation System. In *Databases and Information Systems*. J. Barzdins, A. Caplinskas (Eds.) Kluwer Academic Publishers. Dordrecht/Boston/London, p. 209-220.
- Dzemydiene D., Naujikiene R. 2003. Structural Analysis of Legal Environment Protection Information in the Estimation of Pollution Factors. In: H. Pranevicius, E. Zavadskas, and B. Rapp (Eds.), *Proc. of International Conference "Modelling and Simulation of Business Systems"*. KUT Technologija press, p. 324- 328.
- Dzemydienė D., Maskeliūnas S., Jacobsen K. 2008. Sustainable management of water resources based on web services and distributed data warehouses// *Technological and Economic Development of Economy. Baltic Journal on Sustainability*. Vilnius: Technika, Vol. 14, No. 1, p. 38-50.
- Egyedi T.M. (2007). Standard-compliant, but incompatible? *Computer Standards & Interfaces*. Vol. 29. Issue 6, p. 605-613.
- Environment 2010: Our future, our choice. The Sixth EU Environment Action Programme 2001-2010. Luxembourg. 2001. Available from (<http://www.environment.com>).
- Jacobsen, K.; Maskeliunas S. (2003). Web service-based information system of water resource management. In: Jean Claude Rault (Eds.), *ICSSEA 2003, 16th International Conference "Software & Systems Engineering and Their Applications"*, Proceedings. 5. Centre pour la Maitrise des Systemes et du Logiciel, CNAM, Paris, France, p. 1/10-10/10.

- Karnegy B. W, Filion Y. R. (2005) Linking Health Concepts in the Assessment and Evaluation of Water Distribution Systems // *Bulletin of Science, Technology & Society*. Vol. 25, No. 3, p. 247-253.
- Komatsoulis, G.A.; Warzel, D.B.; Hartel, F.W.; Shanbhag, K. ; Chilukuri, R. ; Fragoso, G. ; Coronado, S.; Reeves, D.M.; Hadfield, J.B.; Ludet, C.; Covitz, P.A. (2008). caCORE version3: Implementation of a model driven, service-oriented architecture for semantic interoperability // *Journal of Biomedical Informatics*. Vol. 41, Issue 1, p. 106-123.
- Legal information system LITLEX. Available from <http://www.litlex.lt/portal/ml/start.asp?lang=eng>. 2006.
- Mysiak J., Giupponi C., Rosato P. (2005) Towards the Development of a Decision Support System for Water Resource Management // *Environmental Modelling & Software*. Vol. 20, Issue 2. 2005, p. 203-214.
- Moavenzadeh F., Hanaki K., Baccini P. (Eds.) (2002). *Future Cities: Dynamics and Sustainability*. Series: Alliance for Global Sustainability Book series, Vol.1, p.-248
- Noe, J.D.; Nutt, G.J. (1973). Macro E-nets for representation of parallel systems // *IEEE Transactions on Computers*, C-22(5), 1973, p. 718-727.
- Rajasekaram V, Nandalal K.D.W. (2005) Decision Support System for Reservoir Water Management Conflict Resolution // *Journal of Water Resources Planning and Management-ASCE*. Vol. 131. Issue 6, p. 410-419.
- Richter B. D., Mathews R., Harrison D.L., Wigington R. (2003) Ecologically Sustainable Water Management: Managing River Flows for Ecological Integrity // *Ecological Applications*, Vol. 13, Issue 1, p. 206-224.
- Liebowitz J.; Megholughe I. (2003). Asset of Frameworks to Aid the Project Manager in Conceptualizing and Implementing Knowledge Management Initiatives // *International Journal of Project Management*. 21 (5): 189-198.
- Swanson D.A., Pintér L., Bregha F., Volkery A., Jacob K. (2004). National Strategies for Sustainable Development: Challenges, Approaches and Innovations in Strategic and Co-ordination Actions. IISD.
- Saarenmaa H. 2002. Reportnet: Development of Common Tools and a Shared Information Infrastructure for the European Environmental Information System. NFP/EIONET Group Meeting papers, 2nd edition, http://www.eionet.eu.int/EIONET_Tech/sii
- Zavadskas E.K., Kazlauskas A., Maciunas E. Vainiunas P., Marsalka A. 2007. Real Estate's Market Value and a Pollution and Health Effects Analysis Decision Support System// Yuhua Luo (Ed.) Cooperative Design, Visualization, and Engineering, 4th International Conference, Lecture Notes in Computer Science 4674. Springer. CDVE, 191-200.

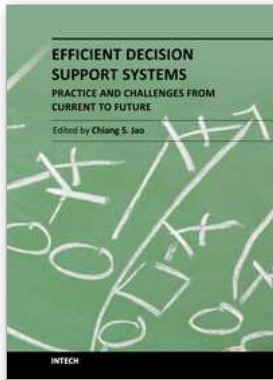

Efficient Decision Support Systems - Practice and Challenges From Current to Future

Edited by Prof. Chiang Jao

ISBN 978-953-307-326-2

Hard cover, 542 pages

Publisher InTech

Published online 09, September, 2011

Published in print edition September, 2011

This series is directed to diverse managerial professionals who are leading the transformation of individual domains by using expert information and domain knowledge to drive decision support systems (DSSs). The series offers a broad range of subjects addressed in specific areas such as health care, business management, banking, agriculture, environmental improvement, natural resource and spatial management, aviation administration, and hybrid applications of information technology aimed to interdisciplinary issues. This book series is composed of three volumes: Volume 1 consists of general concepts and methodology of DSSs; Volume 2 consists of applications of DSSs in the biomedical domain; Volume 3 consists of hybrid applications of DSSs in multidisciplinary domains. The book is shaped upon decision support strategies in the new infrastructure that assists the readers in full use of the creative technology to manipulate input data and to transform information into useful decisions for decision makers.

How to reference

In order to correctly reference this scholarly work, feel free to copy and paste the following:

Dale Dzemydiene and Saulius Maskeliunas (2011). Development of Multi-Componential Decision Support System in Dynamically Changing Application Domain of Environment Protection, Efficient Decision Support Systems - Practice and Challenges From Current to Future, Prof. Chiang Jao (Ed.), ISBN: 978-953-307-326-2, InTech, Available from: <http://www.intechopen.com/books/efficient-decision-support-systems-practice-and-challenges-from-current-to-future/development-of-multi-componential-decision-support-system-in-dynamically-changing-application-domain>

INTECH
open science | open minds

InTech Europe

University Campus STeP Ri
Slavka Krautzeka 83/A
51000 Rijeka, Croatia
Phone: +385 (51) 770 447
Fax: +385 (51) 686 166
www.intechopen.com

InTech China

Unit 405, Office Block, Hotel Equatorial Shanghai
No.65, Yan An Road (West), Shanghai, 200040, China
中国上海市延安西路65号上海国际贵都大饭店办公楼405单元
Phone: +86-21-62489820
Fax: +86-21-62489821

© 2011 The Author(s). Licensee IntechOpen. This chapter is distributed under the terms of the [Creative Commons Attribution-NonCommercial-ShareAlike-3.0 License](#), which permits use, distribution and reproduction for non-commercial purposes, provided the original is properly cited and derivative works building on this content are distributed under the same license.