

# Thermal-Hydraulic Analysis in Support of Plant Operation

Francesc Reventós  
*Technical University of Catalonia*  
*Spain*

## 1. Introduction

Many different engineering tasks are performed in support of operation of nuclear power plants with the aim of carrying out an effective and safe exploitation. Among such activities maintenance, core follow-up, refuelling and analyzing operating experience are the most commonly cited. Thermal-hydraulic analysis is an important issue that could help many different aspects of the engineering activity taking care of plant operation.

Integral Plant Models prepared using system codes are a valuable tool to carry out analytical activities devoted to contribute to engineering support to plant operation.

Most of the issues and tasks presented in the chapter are part of the job description of the so called thermalhydraulic analyst supporting plant operation (Reventós, 2008). Usually, this analyst is an engineer belonging to the technical team that takes care of engineering plant support. In many plants such engineer takes care of plant models and he personally performs at least the first approach analysis of any of the issues involved. Depending on the amount of work needed to carry out each specific analysis the whole work or only a part of it is done by him. In the first case the benefits are clear since he knows the plant and he uses the information produced or treated by the team he belongs to. In the second case, when the amount of work is too large, the thermalhydraulic analyst will take care of the technical subcontracting of the analysis. The benefits in this latter case are also clear since he is coordinating a task well known to his own calculating experience.

This chapter has three different sections. The first one gives some detail on thermal-hydraulic analysis tasks related to operation. The second clarifies some features that are specific of Integral Plant Model. Especially, it establishes how the nodalization is qualified. Finally, the third briefly presents some relevant results of one example of analysis performed in such context along with the concise description of other two cases.

## 2. Thermalhydraulic analysis tasks related to Nuclear Power Plant (NPP) operation

A tentative list of issues concerning the contents of this section could be the following: Thermal-hydraulic analysis of Probabilistic Safety Assessment (PSA) and Emergency Operating Procedures (EOP) sequences, Dialogue with regulatory body and fuel designer, Analysis of actual transients, NPP start-up tests analysis, Transient analysis for training support, Design modifications and Improvement of plant availability.

Safety Reports from International Atomic Energy Agency (IAEA) and specially (IAEA, 2002) and (IAEA, 2006) are strongly related to the mentioned list of tasks. These documents were developed based on broad international consensus and they describe types and rules for performing computational analyses devoted to both being built and operating plants. The purpose of this section is not to describe every related task but to add some aspects that are specific of the functions of the analyst working in support of plant operation.

In fact every utility or every manager having the responsibility of organizing engineering support to plant operation decides which tasks are to be fulfilled by the thermalhydraulic analyst. Since it is clear that the best estimate (BE) prediction of a scenario helps communication on any engineering subject related to dynamic behaviour, it is difficult to know what comes first task definition or analytical capabilities. In many occasions managers decide to integrate the analyst in the engineering group dealing with support to plant operation. Group objectives are clear and depending on the proved analytical capabilities of the simulating tools the thermalhydraulic analyst results become useful for different purposes.

The thermal-hydraulic analysis of PSA sequences is a well known engineering activity. PSA sequences analyses are normally performed using integral BE plant models (Reventós, 2007a) (Reventós, 2006). These are a kind of studies that fit perfectly in the job description of the analyst. Again IAEA rules are normally followed and no additional comments are needed. It is also one of these pieces of work that are usually subcontracted to engineering companies due to the amount calculations needed.

Something similar occurs with the analyses devoted to Emergency Operating Procedures (EOPs) validation. In fact they are, from calculation point of view quite close to those related to PSA. Integral Plant Models prepared using BE system codes are again the suitable tool for the analysis.

As an enhancement the last two activities BE calculation results are also useful to the dialogue with regulatory body or fuel designer. Sensitivity calculations on the treated scenarios help understanding the related engineering judgements.

The analysis of operating experience is a quite complex activity that needs to coordinate the efforts of many different engineering teams belonging to the utility itself and external organizations. The study of actual transients occurred in the plant usually involves different approaches. The simulation of actual transients produces in-depth knowledge of their dynamic behaviour. It is also helpful to investigate and to determine the cause-effect relationships of the occurred transient (Reventós, 1993) (Reventós, 2001) (Llopis, 1993a). One of the most powerful arguments in favour of these kinds of analysis is that they provide the possibility of generating time trends of functions and magnitudes that are not collected by plant instrumentation. Last section of this chapter shows an example of this capability.

As it usually happens with experiments performed in test facilities, start-up tests of NPP need also pre and post test calculations. The pre-test or the predictive study of NPP start-up tests is extremely helpful for the test coordinator in order to avoid unexpected interactions and delays that could give rise to economic losses (Llopis, 1993b). Competitiveness goals of the electricity business have led the company running the plant to minimize the number of start-up tests to be performed. This kind of analysis helps to reduce the number of tests to only those that have proven benefits for both operation and safety. The expected benefit is usually either better knowledge of dynamic behaviour or the correct performance of a system or instrument. Apart from these important activities related to start-up tests,

standard post-test analyses could also become very significant. Important adjustments of the plant model arise very often from the studies carried out as post-test analyses.

Besides these basic activities presented above there are other less common tasks that are carried out in many cases by the analyst. Among such tasks one can find activities related to training and also all the studies intending to clarify systems interactions.

The former include not only the validation of plant training simulators but also the analyses devoted to direct training actions.

The latter needs some explanation on how it came to engineering organizations. The progress of BE codes development came out with new codes with a high performance in simulating not only core or primary system thermalhydraulics but also controls, other hydrodynamic systems and core neutron-kinetics. This development ended with powerful control blocks, with a huge amount of logic and real variables and the capability of using control equations to simulate many different phenomena quite far from the original intended uses. Such innovative uses started with plant design modifications analyses, having the goal of establishing the impact that modifications in components or systems may have on the interactive global operation of the plant. And later on, other subjects came out like set-point adjustment, other technological changes, or even the improvement of plant availability.

### 3. Integral plant model

This section clarifies some features that are specific of Integral Plant Models. Especially, it establishes how the nodalization is qualified. For this reason this part will emphasize two different aspects. The first is related to the main differences between the nodalizations used in safety analysis and those used for this particular aim. The second one is the special qualification process needed for the model in order to properly fulfil the objective of contributing to plant operation support. Although extensive technical literature exists aimed at establishing the requirements needed to qualify a NPP model, most of this literature is focused on qualifying a model for licensing uses.

The first task to be performed is selecting the code to be used. Taking into account the list of issues presented in the last section, a BE code seems the right option. Maybe some aspects of the presented issues could be solved by conservative or simplified codes but it is generally accepted that a BE code provides the right approach for support of operation issues.

The options are not many, since only a few BE codes exist. Codes like Relap5, TRACE or Cathare are the most used currently. The right code has to be available for the engineering organization and properly documented and maintained. Documentation of a code is the so called code manual which includes a huge amount of information on how the code calculates as well as how one can certify that the calculation is performed properly. Code manuals follow an established organization that includes:

- Code structure
- System models and solution methods
- User's guide and input requirements
- Developmental assessment
- Models and correlations
- User's guidelines
- Validation of numerical techniques
- Summaries of independent code assessment reports
- Programmers manual

Once the code has been selected, the next task is analysing the available design information of the plant such as drawings, equipment specifications, data sheets and descriptive documents produced by component manufacturers. All this information is used to prepare the nodalization: control volumes are defined with junction data, as well as all the details needed. Figure 1 shows an example on the relationship between a drawing of a detail of the reactor vessel and the corresponding nodalization diagram. Following the code manual all this information is organized as an input deck that will be read by the code. The input deck use to be a text file. All these tasks are properly documented in a "Nodalization Description Report". Strict maintenance is performed by up-dating both the input deck and the descriptive documents. Quality assurance of these activities is an important issue related to establishing procedures and keeping data bases for control changes.

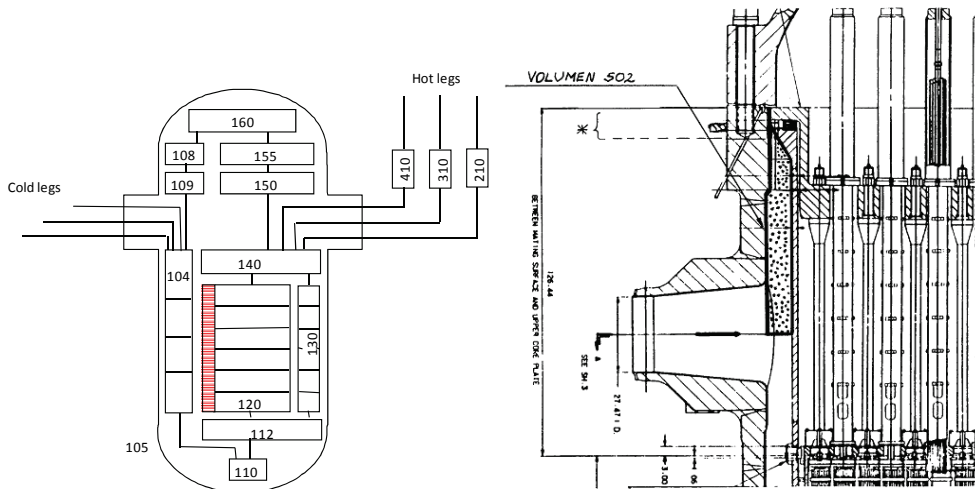

Fig. 1. Reactor vessel: detailed drawing and nodalization

The main differences between the nodalizations used in safety analysis and those used for this particular aim are drawn from what is specified in the previous section. Since the analyst wants his plant model being valid for a large amount of cases, the model has to be quite complete.

Examples of such differences are the following. For instance, in nodalizations used in safety analysis, control systems are often omitted, since many analyses have to be performed assuming that they fail.

Manual action model can be another example. In many safety scenarios manual actions are not considered following the design basis specification. A similar comment can be done for neutron-kinetic model, interlocks or non-safety systems.

If the analyst wants to be able to study actual transients in normal or abnormal operation, at a definite time of the cycle, the most relevant control systems have to be implemented in the model as well as neutron-kinetic model, interlocks and non-safety systems. The limits or borders of the nodalization depend on the scenario to be simulated and following the purpose of the analyst tasks the model intends to cover an important part of the plant. For this reason such nodalizations are often called Integral Plant Models. Sometimes, once a

particular study is started, some specific development is performed in order to complete the scope needed to simulate the scenario to be analyzed.

Figure 2 shows an example of the main nodalization diagram of an Integral Plant Model used for such purpose. Some other diagrams representing: safety injection systems, steam lines, main and auxiliary feed-water, and detailed diagrams of vessel, pressurizer and steam generators are also part of the supporting documentation.

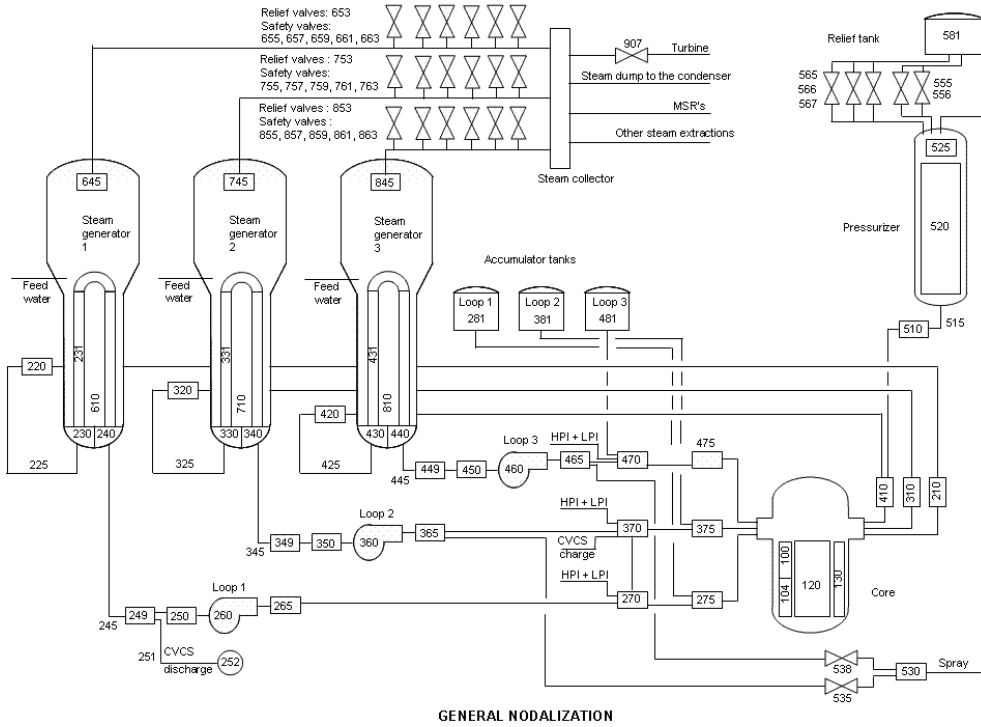
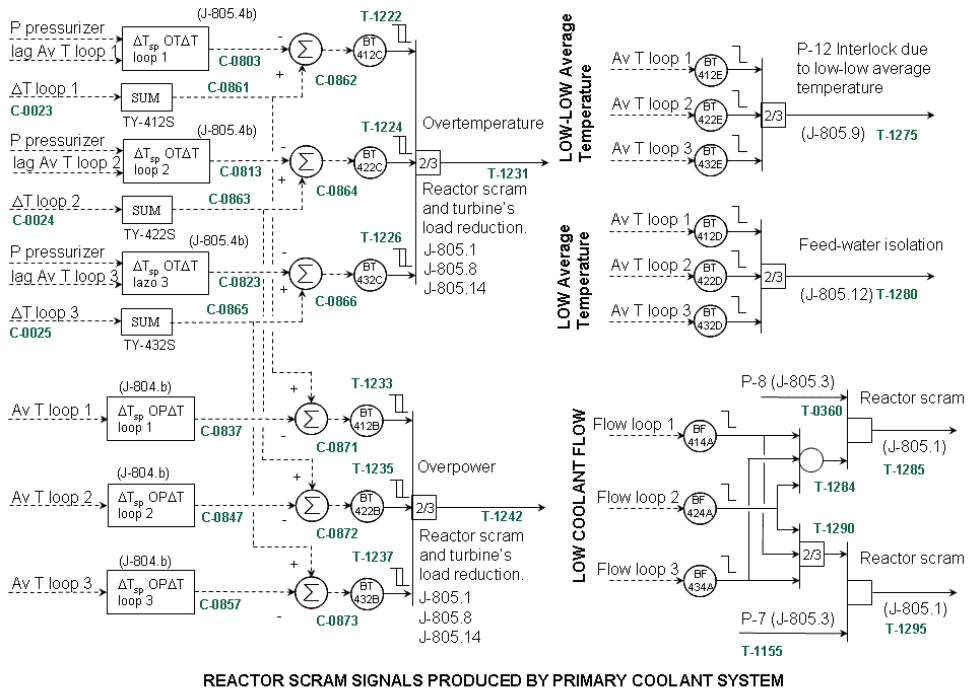

Fig. 2. Example of main nodalization diagram

Figure 3 shows an example of a logic diagram implemented for another similar model. Quite a great number of control systems with a degree of complexity as in the case of Figure 3 are usually included in an Integral Plant Model.

Once the model has been prepared including all specific features and the input deck describing the plant is ready, the nodalization has to be qualified. A general strategy (Reventos, 2007a) distinguishes between Basic and Advanced Qualification Processes. Both are considering comparisons between the results of the simulations and data collected by plant instrumentation. As a general statement when predictions are reasonably close to actual time trends (see figure 4) the nodalization is considered to be validated. The number of compared parameters and their significance are an important point. Figure 4 shows the time trends of Steam Generator narrow range level in a load rejection transient. As can be seen, the predicted values are in close agreement with actual ones.



VANDELLÒS N.P.P.

Fig. 3. Example of a logic diagram

Basic Qualification process is usually performed following guidelines and widely recommended good practices. Recommendations can be found in different publications among them: the code manual itself (see chapter called User's guidelines) and also some specific reports of international organizations like OECD/CSNI (Ashey, 1998) and IAEA (IAEA, 2002). Different existing methodologies devoted to certify the acceptability of the qualification process are available. Most of them follow similar rules and steps like steady state and transient qualification (Berthon, 2005) and Kv scaled calculations (Martínez, 2008). The methodology described in the article (Petruzzi, 2005) is especially relevant and complete since it uses not only qualitative comparisons of calculated and experimental time trends but also it evaluates quantitatively the accuracy of the simulation.

The second level is the so-called AQP and is carried out if the model is to be used not only for licensing but also for each type of transient analysis presented in the previous section. The description of the methodology can be found in (Reventós, 2007a), along with some detail on the most specific difficulties usually encountered in such process.

The most important thing that needs to be considered in this additional plant specific process is the availability of plant data related to meaningful sets of qualification transients. Dynamic transient behaviour is not frequent in operating plants. The number of scheduled tests is also limited. Some start-up tests are performed at the beginning of each cycle, but others are only repeated from time to time.

Plants can undergo major design modifications such as Steam Generator replacement. As validation is plant specific, changes have to be considered. It could be said that after any

important modification a new model qualification is needed. Fortunately, some essential systems and components remain the same and this will be useful in order to reduce engineering effort.

### Vandellòs II N.P.P. - Load rejection from 100% to 50%.

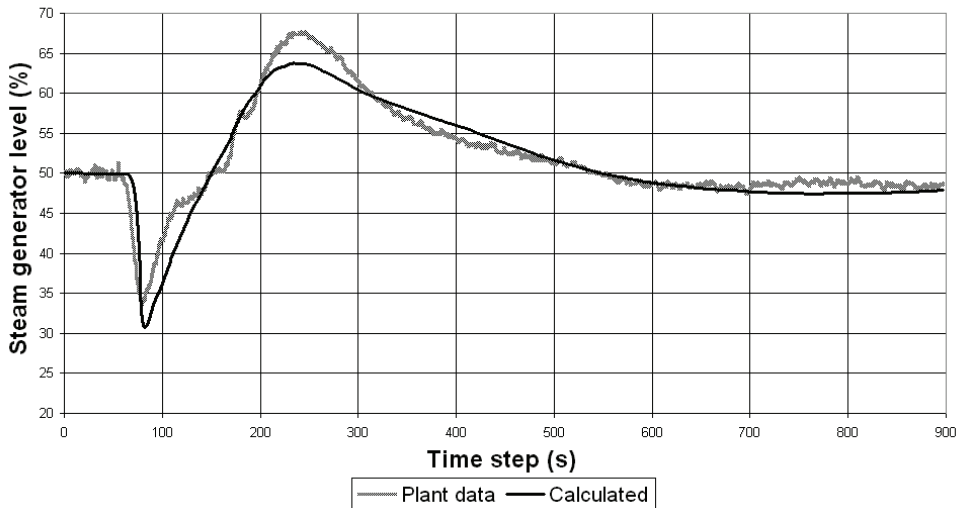

Fig. 4. Comparison between calculated and predicted time trends

The concept of configuration is highly helpful for a fruitful use of the limited amount of available plant data of meaningful sets of transients suitable for validation. A plant configuration is the state of the plant for a period of time in which no important changes are made. It is understood that important changes are those related to heavy equipment replacement, essential system modification and power level variation. Examples of configuration descriptions of a given plant along with some comments on distinctive features could help to illustrate this issue.

Some conclusions can be drawn from the analysis of the information above. Old configurations have usually two important problems: low quality of data and a lack of detailed as-built information. In spite of this, they have a very interesting advantage: a large amount of unexpected transients. Current configurations also have advantages and disadvantages. Among the former: high quality of data and proper documentation of new systems. Among the latter: the limited number of unexpected transients and start-up tests.

Taking all the above-mentioned features into account, a careful selection of transients is usually performed along with the identification of systems that remain unchanged in the different configurations. These identification tasks define the qualification process, which relies on the comparison of plant data and model prediction for the selected transients.

The AQP is a progressive activity that confers an important level of qualification to the Integral Plant Models and provides the procedure to improve this level gradually after the analysis of transients that may occur in the future.

The plan has three main steps:

- Preparing the qualification matrix.
- Executing assessment calculations.
- Performing comparison and final evaluation.

Configuration Period	Distinctive features	Remarks
1 <sup>st</sup> configuration (1983-1995)	Old Steam Generators	Difficulties in data recording Large number of unexpected transients
2 <sup>nd</sup> configuration (1995-1999)	New Steam Generators New Feed Water Control System New value of average temperature	Few unexpected transients Complete set of start-up tests
3 <sup>rd</sup> configuration (1999 - 2002)	Approximately 8% power up-rating	Very few unexpected transients Selected start-up tests
4 <sup>th</sup> configuration (2002 - today)	Approximately 1% power up-rating	Very few unexpected transients Limited number of start-up tests

Table 1. Ascó configurations

The qualification matrix is prepared by establishing a list of plant transients suitable for qualification and another list of systems and components needed for advanced qualification. The first list is prepared in a comprehensive way. Some decisions can be made in order to obtain a good level of qualification with reasonable effort. Some configuration can be interesting due to the number of unexpected transients but the engineering effort to maintain the corresponding model could be excessive. In this case, it is better to discard the configuration provided that there are sufficient recorded transients in the rest of the configurations.

The second list has to be prepared to identify which systems and components have had a significant effect on the transients analysed to date or intended to be analysed in a near future. Following what has been established in the previous section, this includes a complete set of calculations related to PSA and others to EOP analysis.

Once both lists were ready, the information was organized, as can be seen in Figures 5 and 6. The former is the qualification matrix and the latter shows a detailed part of it. Each transient is set to a column (i) and each system or component to a line (j). In the box corresponding to column i and line j, one or two names of parameters are set. These are the key parameters to check the correct functioning of system j, which is properly recorded in transient i.

If the key parameter of a system or component is properly documented in more than one transient, the input is adjusted to simultaneously match, or at least to reasonably approach, all the different recorded behaviours. In this way the matrix helps the analyst to keep track of his experience and make it useful for future modelling tasks.



		* transient 1 *	* transient 2 *	* transient 3 *	* transient 4 *	* transient 5 *	* transient 6 *	* transient 7 *
		Reactor trip due to low flow	Reactor trip due to low SG level	Load rejection from 100% to 50%	Load rejection from 100% to 50%	Load swing from 75% to 65%	Load swing from 65% to 75%	Load rejection from 100% to 50%
<b>Pressurizer's safety system</b>	valves	-	-	-	-	-	-	-
	control	-	-	-	-	-	-	-
<b>Pressurizer's relief system</b>	valves	-	-	-	-	-	-	-
	control	-	-	-	-	-	-	-
<b>Pressurizer spray</b>	valves	Spray valve's position/Primary pression	Spray valve's position/Primary pression	Spray valve's position/Primary pression	Primary pressure	Spray valve's position/Primary pression	Spray valve's position/Primary pression	Primary pressure
	control	-	-	-	-	-	-	-
<b>Pressurizer's heater</b>	valves	Primary pressure	Primary pressure	Primary pressure	Primary pressure	Primary pressure	Primary pressure	Primary pressure
	control	-	-	-	-	-	-	-
<b>Main feedwater</b>	main valves	-	-	Main feedwater's flow	Main feedwater's flow	Main feedwater's flow	Main feedwater's flow	Main feedwater's flow
	main valves control	-	-	-	-	-	-	-
	bypass valves	-	-	-	-	-	-	-
	bypass valves control	-	-	-	-	-	-	-
<b>Auxiliary feedwater</b>	turbopump control	-	-	Turbine driven pump speed	Turbine driven pump speed	Turbine driven pump speed	Turbine driven pump speed	Turbine driven pump speed
	turbine driven pump's valve control	Auxiliary feedwater's flow	Auxiliary feedwater's flow	-	-	-	-	-
	pump valves control	Auxiliary feedwater's flow	Auxiliary feedwater's flow	-	-	-	-	-
	control	-	-	-	-	-	-	-
<b>High pressure injection system</b>	control	-	-	-	-	-	-	-
<b>Low pressure injection system</b>	control	-	-	-	-	-	-	-
<b>Steam dump</b>	control	Average temperature	Average temperature	Average temperature	Average temperature	Average temperature	Average temperature	Average temperature
<b>Turbine</b>	control	-	-	Turbine's valve position	-	Turbine's valve position	Turbine's valve position	-
<b>Control rod system</b>	control	-	-	-	-	-	-	Control rod insertion

Fig. 5. Qualification matrix

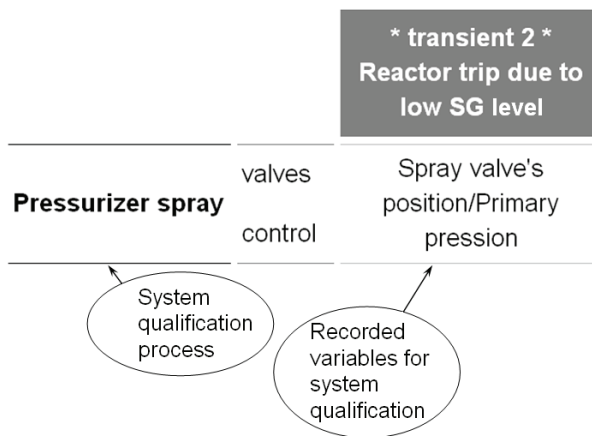

Fig. 6. Detailed box of the qualification matrix

The matrix is also helpful for new studies. The analyst, knowing the relevant aspects of the scenario to be studied, could easily check in the table if the model used is properly qualified. The matrix can also be easily enhanced either by adding columns related to new suitable transients or adding new lines related to systems needed for qualification.

#### 4. Example cases

This section briefly presents some relevant results of one example of analysis performed along with the concise description of other two cases. All the considered cases are related to actual situations in which the scenarios were studied by analysts using thermal-hydraulic codes and prepared nodalizations.

The example presented is the analysis of a reactor trip operating event due to high variation of neutron flux occurred in the Vandellòs-II NPP. More detail can be found in (Reventós 2010).

The transient was initiated by an electrical grid disturbance due to a storm, which caused disconnection of the main output switch, while the in-site electrical equipment switch remained connected. The plant therefore started operating on auto-consumption. Due to the loss of off-site power, the reactor and the turbine tripped and natural circulation was established. Later on, off-site power was recovered and operators brought the plant to Hot Zero Power (HZP).

The initial phase started with the loss of off-site power and lasted until the reactor trip. The sequence of events that caused the shutdown of the reactor lasted less than 1.0 second and is not easily studied mainly because of the short time of occurrence and also because of the relatively high time step of the collected time-trends. The post-trip event list did not help much.

The only symptom that pointed to a credible explanation was related to some primary flow data recorded by plant instrumentation. These data revealed that in 2.0 seconds the primary flow increased by about 4 or 5%.

Since the plant was on auto-consumption, the electrical frequency could have increased and could have resulted in the subsequent increase of the Reactor Coolant Pump (RCP) speed. This suspicion needed to be confirmed. A calculation was performed in order to corroborate this hypothesis.

In order to approximate their real behaviour, different values of RCP speed were introduced in the BE model as a boundary condition until the primary flow increased by about 4 or 5%, as had been observed in the plant. This flow increase produced a decrease in moderator temperature that could not be measured by usual temperature instruments (Figure 7) in the first second after the initiating event.

A calculation, using an Integral Plant Model, produced the evolution of temperature node by node for the whole core. Results were analyzed for all nodes and the temperature corresponding to the central node is shown in Figure 8. This decrease in core temperature produced an increase in power due to the effect of moderator temperature (Figure 9). This figure shows the power increase until the inflection due to the beginning of rod insertion at 0.6 seconds and the full decrease of power after time=1.0 second as an effect of the negative reactivity introduced. It must be pointed out that the time of insertion is about 1.5 seconds which is consistent with the power time trend.

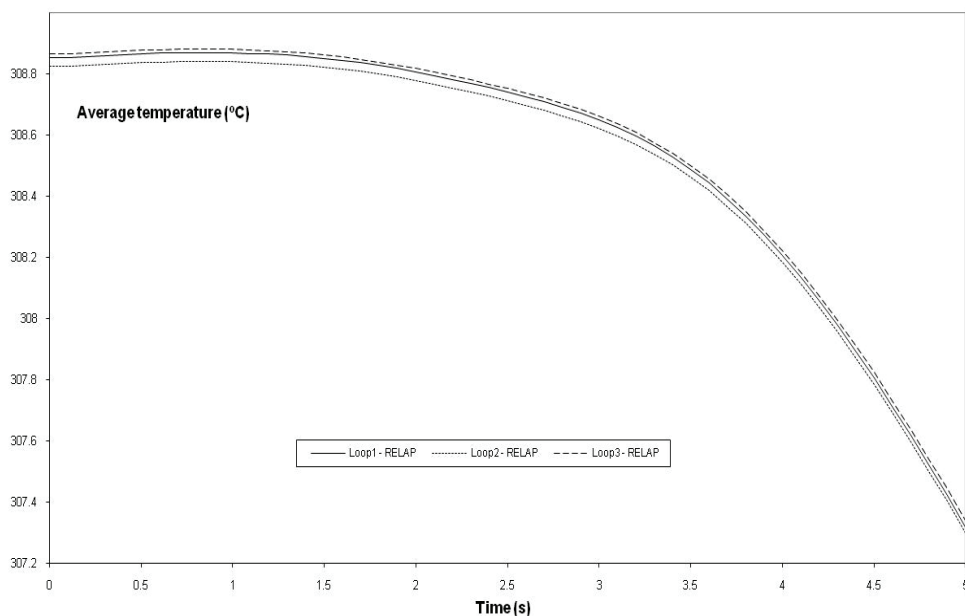

Fig. 7. Calculated average temperature

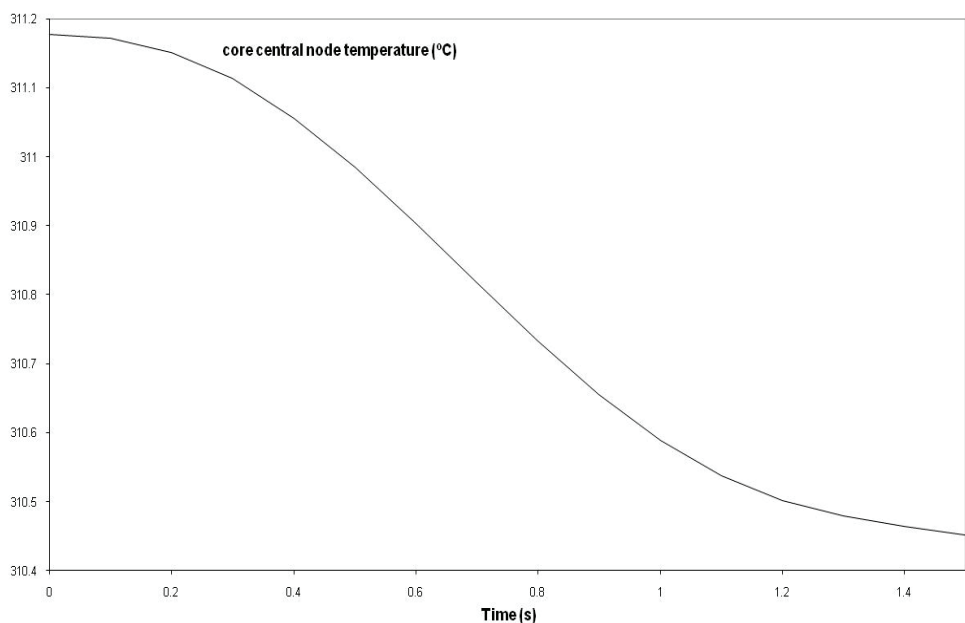

Fig. 8. Calculated temperature of core central node

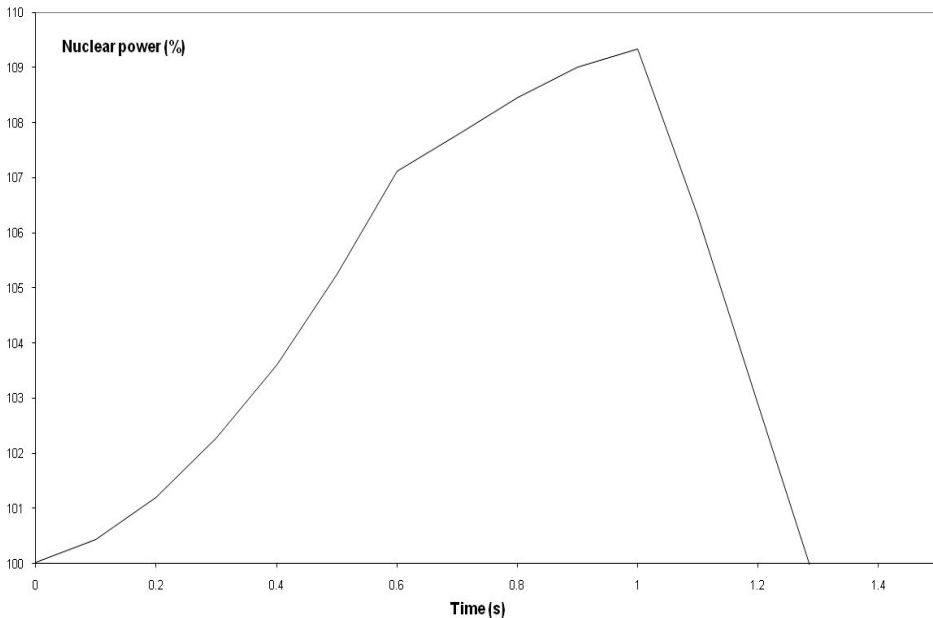

Fig. 9. Calculated nuclear power

Although the neutronics of the Integral Plant Model used, is usually not very detailed (it is a point-kinetics model), it is capable of predicting the increase in reactor power due to moderator temperature decrease and, as a consequence, the reactor trip due to high variation of neutron flux.

The model has been extremely useful in clarifying the sequence of events corresponding to the transient that actually occurred in the plant on December 2, 1991. The study provided an answer to the concerns of the person responsible for operation related to the scenario and was also helpful to identify the inadequacy of thermocouple location as a design deficiency. This identification was a necessary step previous to its replacement that took place soon after the event.

The analysis is a good example of how integral plant models can result in a real benefit as part of the support activities to the operation of a nuclear power plant.

The transient was included in the Qualification Matrix and it is currently being re-analyzed after any major change performed in the model.

Operating events, as the one depicted above, are maybe the most significant analyses performed for support of plant operation. Other cases are analyzed. Two concise descriptions are presented below.

Some analyses are performed, as the one that follows, in strong connection to both EOP and PSA. Studies like this one are maybe not the more significant but they are for sure the most usual. The studied sequence consists in a total loss of Feed Water (FW).

EOP/PSA transient analyses are traditionally performed using Integral Plant Models. Results were a successful first approach to operation support and the study was carried out following some concern of the person responsible of plant operation. More detail on the analysis can be found in (Reventós, 2007b).

After the total loss of FW takes place, heat transfer from the primary to the secondary side degrades and causes a decrease of the SG level. Once this symptom has been detected, the procedure starts by opening 1 PORV and actuating 1 HPIS train. Water injected into the primary system at low temperature is heated by decay power and comes out through the relief valve. The procedure results in a pressure decrease which means that energy produced is completely extracted.

The base case brings the plant to a safe situation without violating design limits as hot rod clad temperatures show a general decreasing trend during the whole transient. The calculation properly captures the main relevant thermal-hydraulic features of the scenario. Once the base case was successfully simulated, a strategy was defined to answer the following questions:

- Impact of PORV and HPIS partial availability (less than 2 PORV or 2 HPIS trains)
- Maximum time to start the procedure after the level symptom occurs
- Relevant heat sink recovery phenomena (although recovery actions are quite fast, they involve different components and need some time)

The answers to the questions were obtained and the operation team got a better general picture of the scenario and related phenomena. As obviously each answer has an impact on the others, the strategy applied was to launch quite a large number of combined scenarios in order to cover different situations that could potentially occur. For a given combination of component availability, a series of different procedure starting times have been tried and for each of these calculations heat sink recovery was also imposed at different times. The total number of cases was 61. In this case the complete set of calculations was performed by the analyst.

The next concise description presented in the current context is not related to transient analysis but to slow degradation of a very significant component: the steam generators of a PWR plant. The study was carried out for Ascó NPP.

Due to some problems related to the material used in manufacturing steam generator tubes, degradation was taking place and the probability of having a tube rupture was increasing from cycle to cycle. To face the problem the team giving support to plant operation, started with different engineering actions, most of them were design modifications related to the chemistry of the secondary circuit devoted to replace materials that were supposed to power corrosion. At each reload an Eddy current extensive inspection was carried out in order to quantify the degradation and as a consequence to make a decision on which tubes needed to be plugged. The problem was quite serious because in few years the number of plugged tubes increased at an important rate.

Using the Integral Plant Model of Ascó NPP, an analysis was carried out. The results obtained became interesting information to help decision making. The work done faced both realistic modelling of actual situations and predictive simulation of eventual future plugging.

After each reload and following the actual tube plugging, the plant model was adjusted with realistic criterion. The specific development of the model was to decrease heat exchange surface from primary to secondary side and also to reduce the primary flow area following the actual plugging. The model stabilized at a slightly different working point. Maybe the more interesting parameters to check were the secondary pressure and the stabilized position of turbine valve. Such stable values of Pressure and valve position are shown in Figure 10 along with model predictions as a function of plugging percentage. Checking and comparing such parameters provided additional validation for the specific situation. The validated model could then be used for the usual purposes maintaining its accuracy.

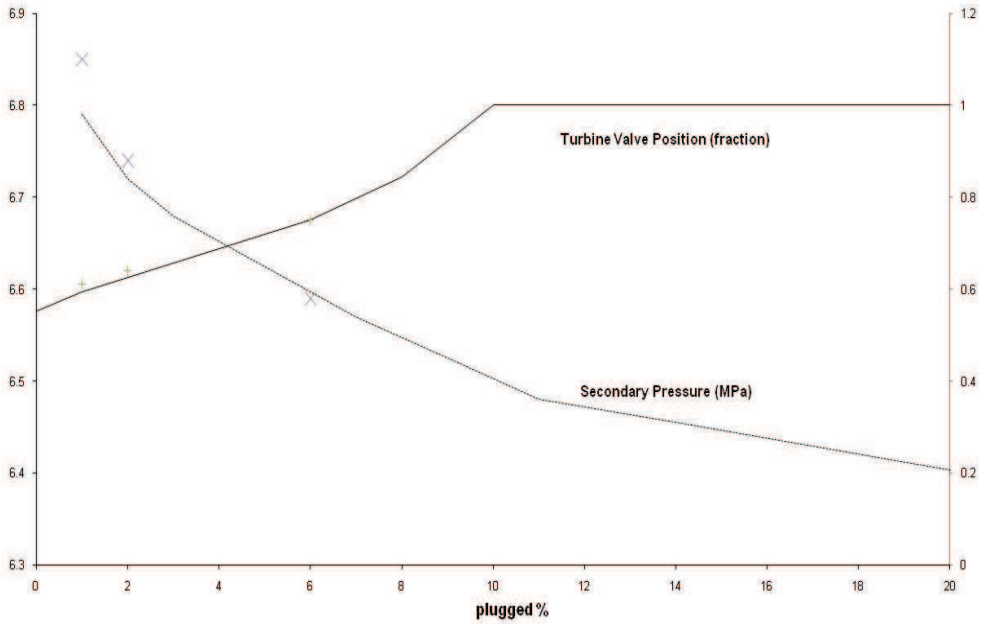

Fig. 10. Secondary pressure and turbine valve position vs. SG tube plugged percentage

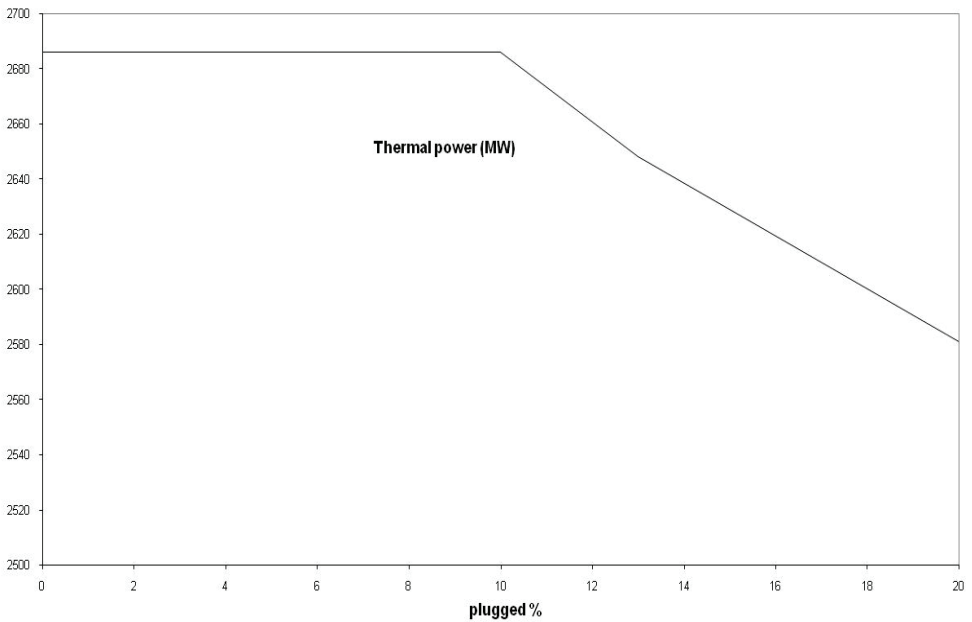

Fig. 11. Thermal power vs. SG tube plugged percentage

The predictive simulation of eventual future plugging was even more interesting. Symmetric and asymmetric configurations were modelled at an increasing plugging percentage and key parameters were evaluated. When plugging percentage increased secondary pressure decreased and turbine valve stabilized at a wider position to compensate and allow the nominal value of steam mass flow (see Figure 10). Once turbine valve at certain plugging percentage reached the fully wide open position the secondary system stopped being able to extract all the thermal power produced. As shown in Figure 11, higher plugging percentages resulted in a thermal power smaller than the nominal one. The predictive simulation gave quite clear results about 3 or 4 cycles (at that time Ascó follow 12 months cycles) before the eventual decrease of thermal power. The results of this analysis, along with other technical studies, became extremely helpful for making the decision of steam generator replacement. The decision was made on time and the replacement was carried out successfully.

## 5. Conclusions

This chapter has shown the relevance of thermal-hydraulic analysis devoted to give support to plant operation. Integral Plant Models prepared using system codes, and properly qualified, are a valuable tool to carry out the studies presented.

It has also been shown the significance of tasks to be performed by the so called thermalhydraulic analyst supporting plant operation. If this analyst belongs to the technical team that takes care of engineering plant support, his studies become more effective.

Taking care of plant models and personally performing at least the first approach analysis of any of the issues involved, is a suitable strategy. Depending on the amount of work needed for each specific analysis, the whole work or only a part of it is done by him. Benefits are clear in both cases.

The examples presented or briefly described illustrate the job of performing thermalhydraulic calculations as a first approach of the analysis of plant dynamic behaviour.

## 6. Acknowledgement

The examples presented in this chapter are related to the NPPs of Ascó and Vandellòs-II operated by ANAV. The author is grateful to the management and the staff of the ANAV for their consent to this publication.

## 7. References

- Ashley R., El-Shanawany M., Eltawila F., D'Auria F., November 1998. *Good Practices for User Effect Reduction*. NEA/CSNI/R(98)22.
- Berthon A., Petrucci A., del Nevo A., Reventós F., September 2005. Consistent code qualification process and application to the LOBI test BL-44. *IAEA Technical Meeting on: Use of a Best Estimate Approach in Licensing with Evaluation of Uncertainties*; Pisa, September 2005
- IAEA, 2002. *Accident Analysis for Nuclear Power Plants*. Safety Report Series No. 23. International Atomic Energy Agency. Vienna.
- IAEA Safety Reports Series N° 48, 2006. *Development and Review of Plant Specific Emergency Operating Procedures*.

- Llopis C., Casals A., Pérez J., Mendizábal R., December 1993. *Assessment of RELAP5/MOD2 against a main feed water turbo pump trip transient in the Vandellòs-II NPP*. International Agreement Report. Nureg/ia-110
- Llopis C., Pérez J., Casals A., Mendizábal R., May 1993. *Assessment of RELAP5/MOD2 against a 10% load rejection transient from 75% steady state in the Vandellòs-II NPP*. International Agreement Report. Nureg/ia-109
- Llopis C., Reventós F., Batet L., Pretel C., Sol I., March 2007. *Analysis of Low Load Transients for the Vandellòs-II NPP. Application to Operation and Control Support*. *Nuclear Engineering and Design*, 237 (2007) 2014-2023
- Martínez V., Reventós F., Pretel C., Sol I.; *Code Validation and Scaling of the ROSA/LSTF Test 3-1 Experiment*; *Topsafe 2008 - European Nuclear Society*; Dubrovnik, Croatia, September-October 2008
- A. Petruzzi, F. D'Auria, W. Giannotti, "Description of the procedure to qualify the nodalization and to analyze the code results", May, 2005.
- Posada J., Martín M., Reventós F., Llopis C., September 1997. *Interactive graphical analyser based on RELAP5/MOD3.2-NPA*. 2nd CSNI specialist meeting on simulators and plant analysers. Espoo-Finland
- Reventós F., Batet L., Llopis C., Pretel C., Salvat M., Sol I.; *Advanced qualification process of ANAV NPP integral dynamic models for supporting plant operation and control*; *Nuclear Engineering and Design* 237 (1) 54-63; 2007
- Reventós F., Batet L., Llopis C., Pretel C., Sol I.; *Thermal-Hydraulic Analysis Tasks for ANAV NPPs in Support of Plant Operation and Control*; *Science and Technology of Nuclear Installations*, Volume 2008, Article ID 153858, 13 pages
- Reventós F., Llopis C., Batet L., Pretel C., Sol I.; *Analysis of an actual reactor trip operating event due to a high variation of neutron flux occurring in the Vandellòs-II nuclear power plant*; *Nuclear Engineering and Design* 240 (2010) 2999-3008
- Reventós F., Batet L., Pretel C., Ríos M., Sol I., March 2007. *Analysis of the Feed & Bleed procedure for the Ascó NPP. First approach study for operation support*. *Nuclear Engineering and Design*, 237 (2007) 2006-2013
- Reventós F., Batet L., Pretel C., Llombart O., Sol I., Romera S., September 2006. *Improving PSA Usefulness Using the Results of Thermalhydraulic Best Estimate Models of ANAV Reactors*. Working Material. IAEA Technical Meeting. *Effective Integration of Deterministic and Probabilistic Safety Analysis in Plant Safety Management*. Barcelona (Spain)
- Reventós F., Sánchez-Baptista J., Pérez-Navas A., Moreno P., December 1993. *Assessment of a pressurizer spray valve faulty opening transient at Ascó nuclear power plant with RELAP5/MOD2*. International Agreement Report. Nureg/ia-121.
- Reventós F., Posada J., Llopis C., Pretel C., Moreno P., April 2001. *Improving NPP availability using thermal hydraulic integral plant models. assessment and application of turbine run-back scenarios*. *Proceedings. 9th International Conference on Nuclear Engineering-icone9*.



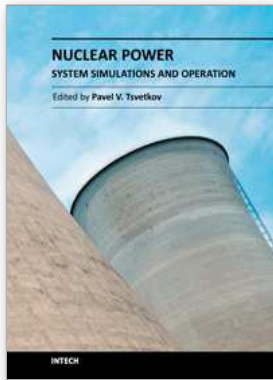

## **Nuclear Power - System Simulations and Operation**

Edited by Dr. Pavel Tsvetkov

ISBN 978-953-307-506-8

Hard cover, 192 pages

**Publisher** InTech

**Published online** 06, September, 2011

**Published in print edition** September, 2011

At the onset of the 21st century, we are searching for reliable and sustainable energy sources that have a potential to support growing economies developing at accelerated growth rates, technology advances improving quality of life and becoming available to larger and larger populations. The quest for robust sustainable energy supplies meeting the above constraints leads us to the nuclear power technology. Today's nuclear reactors are safe and highly efficient energy systems that offer electricity and a multitude of co-generation energy products ranging from potable water to heat for industrial applications. Catastrophic earthquake and tsunami events in Japan resulted in the nuclear accident that forced us to rethink our approach to nuclear safety, requirements and facilitated growing interests in designs, which can withstand natural disasters and avoid catastrophic consequences. This book is one in a series of books on nuclear power published by InTech. It consists of ten chapters on system simulations and operational aspects. Our book does not aim at a complete coverage or a broad range. Instead, the included chapters shine light at existing challenges, solutions and approaches. Authors hope to share ideas and findings so that new ideas and directions can potentially be developed focusing on operational characteristics of nuclear power plants. The consistent thread throughout all chapters is the "system-thinking" approach synthesizing provided information and ideas. The book targets everyone with interests in system simulations and nuclear power operational aspects as its potential readership groups - students, researchers and practitioners.

### **How to reference**

In order to correctly reference this scholarly work, feel free to copy and paste the following:

Francesc Reventós (2011). Thermal-Hydraulic Analysis in Support of Plant Operation, Nuclear Power - System Simulations and Operation, Dr. Pavel Tsvetkov (Ed.), ISBN: 978-953-307-506-8, InTech, Available from: <http://www.intechopen.com/books/nuclear-power-system-simulations-and-operation/thermal-hydraulic-analysis-in-support-of-plant-operation>

**INTECH**  
open science | open minds

### **InTech Europe**

University Campus STeP Ri  
Slavka Krautzeka 83/A  
51000 Rijeka, Croatia  
Phone: +385 (51) 770 447

### **InTech China**

Unit 405, Office Block, Hotel Equatorial Shanghai  
No.65, Yan An Road (West), Shanghai, 200040, China  
中国上海市延安西路65号上海国际贵都大饭店办公楼405单元  
Phone: +86-21-62489820

Fax: +385 (51) 686 166  
www.intechopen.com

Fax: +86-21-62489821

© 2011 The Author(s). Licensee IntechOpen. This chapter is distributed under the terms of the [Creative Commons Attribution-NonCommercial-ShareAlike-3.0 License](#), which permits use, distribution and reproduction for non-commercial purposes, provided the original is properly cited and derivative works building on this content are distributed under the same license.