

# Modelling and Simulation of a 12 MW Active-Stall Constant-Speed Wind Farm

Lucian Mihet-Popa<sup>1</sup> and Voicu Groza<sup>2</sup>

<sup>1</sup>*Politehnica University of Timisoara*

<sup>2</sup>*University of Ottawa*

<sup>1</sup>*Romania*

<sup>2</sup>*Canada*

## 1. Introduction

The conventional energy sources such as oil, natural gas, or nuclear are finite and generate pollution. Alternatively, the renewable energy sources like wind, solar, tidal, fuel cell, etc are clean and abundantly available in nature. Among those the wind energy has the huge potential of becoming a major source of renewable energy for this modern world. In 2008, 27 GW wind power has been installed all over the world, bringing world-wide install capacity to 120.8 GW (GWEC publication, 2009).

The wind energy industry has developed rapidly through the last 20-30 years. The development has been concentrated on grid connected wind turbines (wind farms) and their control strategies. Conventional stall wind turbines are equipped with cage rotor induction generators, in which the speed is almost constant, while the variable speed and variable pitch wind turbines use doubly-fed induction generators or synchronous generators in connection with a power converter (partial rate or full rate). The variable speed wind turbine has a more complicated electrical system than the fixed-speed wind turbine, but it is able to achieve maximum power coefficient over a wide range of wind speeds and about (5-10) % gain in the energy capture can be obtained (Hansen, A.D. et.al, 2001).

In this paper a complete simulation model of a 6 x 2 MW constant-speed wind turbines (wind farm) using cage-rotor induction generators is presented using data from a wind farm installed in Denmark. The purpose of the model is to simulate the dynamical behaviour and the electrical properties of a wind turbine existing in a wind farm. The wind farm model has also been built to simulate the influence on the transient stability of power systems. The model of each wind turbine includes the wind fluctuation model, which will make the model useful also to simulate the power quality and to study control strategies of a wind turbine.

## 2. Wind turbine modelling

In order to simulate the wind turbine as a part of a distribution system, models have been developed for each element and implemented in the dedicated power system simulation tool DiGSiLENT Power Factory.

The purpose of the model is to simulate the dynamical behaviour and the electrical properties of a wind turbine. The modelling of the wind turbine should create a model as

simple as possible from a mechanical point of view, but capable of providing a good description of the electrical characteristics of a wind turbine.

The wind turbine model consists of different component models: wind model, aerodynamic model, transmission model and of the electrical components such as induction generator, soft-starter, capacitor bank and transformer model (Mihet-Popa, 2004). Aerodynamics is normally integrated with models for different wind conditions and structural dynamics.

The wind turbine is characterized by the non-dimensional curves of the power coefficient  $C_p$  as a function of both tip speed ratio  $\lambda$ , and the blade pitch angle,  $\theta_{pitch}$ . The tip speed ratio is the ratio of linear speed at the tip of blades to the speed of the wind.

As shown in Fig. 1, the wind model generates an equivalent wind speed  $u_{eq}$ , which, together with the blade pitch angle  $\theta_{blade}$  and rotor speed  $\omega_{rot}$ , are input to the aerodynamic block. The output of the aerodynamic model is the aerodynamic torque  $T_{rot}$ , which is the input for the transmission system together with the generator speed  $\omega_{gen}$ . The transmission system has as output the mechanical torque  $T_{hss}$  on the high-speed shaft, which is used as an input to the generator model. Finally, the blade angle control block models the active control loop, based on the measured power and the set point.

A simplified block diagram of the wind turbine model is presented in Fig. 1.

## 2.1 The wind speed model

The wind models describe the fluctuations in the wind speed, which influence the power quality and control characteristics of the wind farm. Thus, the wind speed model simulates the wind speed fluctuations that influence the fluctuations in the power of the wind turbines. The wind acting on the rotor plane of a wind turbine is very complex and includes both deterministic effects (mean wind, tower shadow) and stochastic variations due to turbulence (Mihet-Popa, 2003).

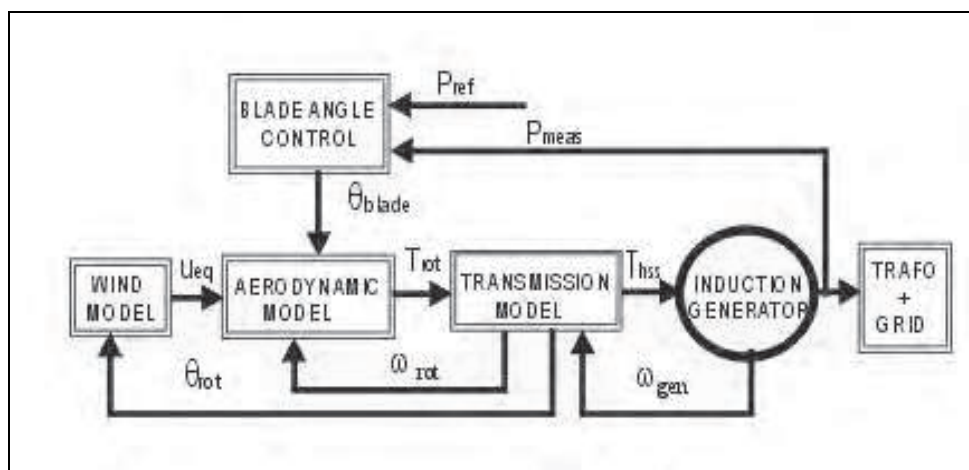

Fig. 1. The block diagram of a simplified model for a constant-speed wind turbine using induction generator.

The simulations shown in Fig. 2 illustrate the effect of the rotational sampling. This hub wind speed is used as input to the rotor wind model to produce an equivalent wind speed

( $u_{eq}$ ), which accounts for the rotational sampling on each of the blades. The wind speed ( $w_{spoint}$ ), which influences the power quality, should be filtered to generate a hub wind speed ( $w_{sfic}$ ).

Figure 2 shows a simulation result for one wind turbine, based on a look-up table, at an average wind speed of 10 m/s.

As expected, both wind speed models fluctuate with three times the rotational frequency ( $3p$ ).

## 2.2 The aerodynamic model

A wind turbine is essentially a machine that converts the kinetic energy of the moving air (wind) first into mechanical energy at the turbine shaft and then into electrical energy (Heier S., 1998).

Fig. 3 describes the conversion of wind power ( $P_{WIND}$ ) into mechanical ( $P_{MEC}$ ) and thereafter into electrical power ( $P_{EL}$ ).

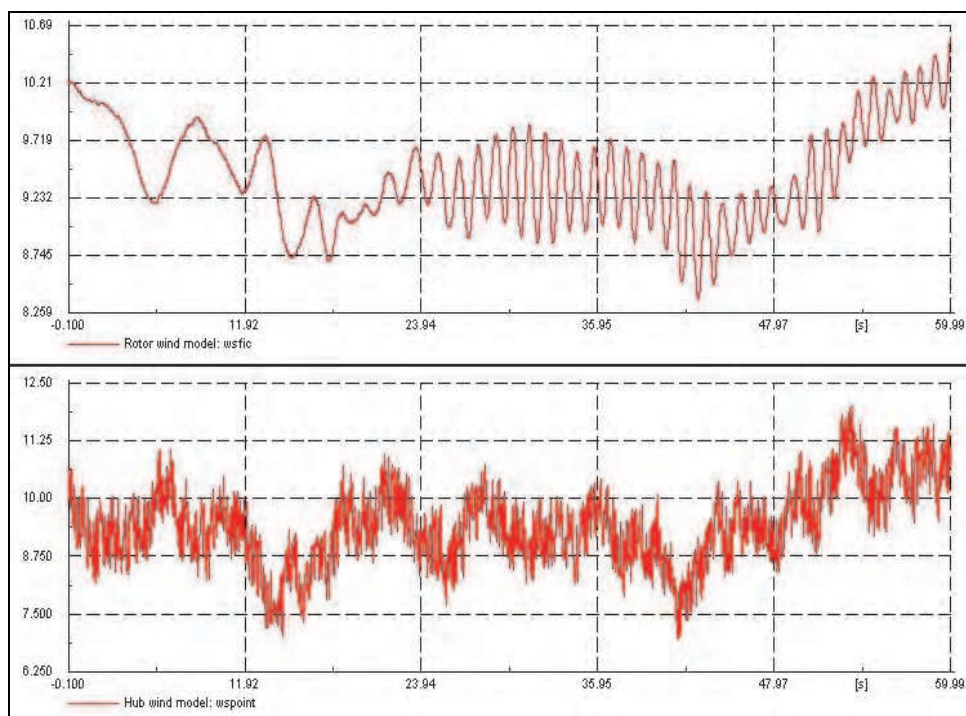

Fig. 2. Rotor wind speed and hub wind speed model.

The interaction of the turbine with the wind is complex but a reasonably simple representation is possible by modelling the aerodynamic torque or the aerodynamic power as described below. Aerodynamic modelling also concerns the design of specific parts of wind turbines, such as rotor-blade geometry and the performance prediction of wind farms. The force of the wind creates aerodynamic lift and drag forces on the rotor blades, which in turn produce the torque on the wind turbine rotor (Hansen et. al, 2003).

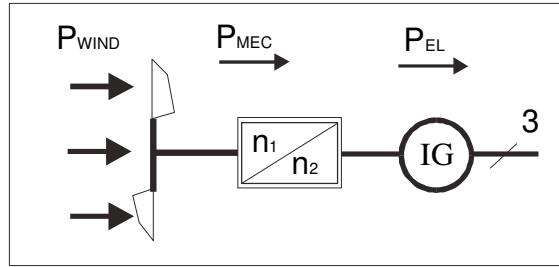

Fig. 3. A block diagram of the power conversion in a wind turbine.

The aerodynamic torque is given by:

$$T_{rot} = \frac{P_{aero}}{\omega_{rot}} = \frac{1}{2\lambda} \rho \pi R^3 C_p(\lambda, \theta_{pitch}) \tag{1}$$

Where  $P_{aero}$  is the aerodynamic power developed on the main shaft of a wind turbine with radius  $R$  at a wind speed  $u_{eq}$  and air density  $\rho$ . It is expressed by:

$$P_{aero} = \frac{1}{2} \rho \pi R^2 u_{eq}^3 C_p(\lambda, \theta_{pitch}) \tag{2}$$

The air density  $\rho$  is depending on the temperature and on the pressure of the air. The dimensionless power coefficient  $C_p(\lambda, \theta_{pitch})$  represents the rotor efficiency of the turbine. It is taken from a look-up table, which contains the specific aerodynamic characteristics for the turbine.

This coefficient depends on the tip speed ratio  $\lambda = \omega_{rot} \cdot R / u_{eq}$  and on the blade angle  $\theta_{pitch}$ ,  $\omega_{rot}$  denotes the rotor speed. For a constant speed turbine, the power coefficient decreases when the wind speed increases ( $\lambda$  small). This fact is used in the passive stall control wind turbine.

The efficiency coefficient ( $C_p$ ) changes with different negative values of the pitch angle ( $0^\circ, -10^\circ, -20^\circ, -30^\circ$ ) but the best efficiency is obtained for  $\theta_{pitch}=0^\circ$ .

The aerodynamic model is based on  $C_p$  curves for the given rotor blades.

### 2.3 Transmission system model

To describe the impact of the dynamic behaviour of the wind turbine, a simple model is considered, where the tower bending mode and the flap-bending mode of the wind turbine are neglected.

It is assumed that all the torsion movements are concentrated in the low speed shaft, as  $T_{lss}$ . Emphasis is placed on the parts of the dynamic structure of the wind turbine, which contributes to the interaction with the grid, i.e. which influence the power. Therefore only the drive train is considered in the first place because the other parts of the wind turbine structure have less influence on power.

The drive train model is illustrated in Fig. 4.

The rotor is modelled by inertia  $I_{rot}$ , low speed shaft only by a stiffness  $k_s$  (the torsion damping is neglected), while the high-speed shaft is assumed to be stiff. Thus the transmission is described by the following equations:

$$I_{rot} \cdot \frac{d\omega_{rot}}{dt} = T_{rot} - T_{lss} \quad (3)$$

$$\frac{dT_{lss}}{dt} = k_s \left( \omega_{rot} - \frac{\omega_{gen}}{n_{gear}} \right) \quad (4)$$

It is also assumed that the losses in the gearbox are zero, thus the gear transmits ideally from the low speed to high speed. The output of the model is:

$$T_{hss} = \frac{T_{lss}}{n_{gear}} \quad (5)$$

where  $n_{gear}$  is ratio of the gear box.

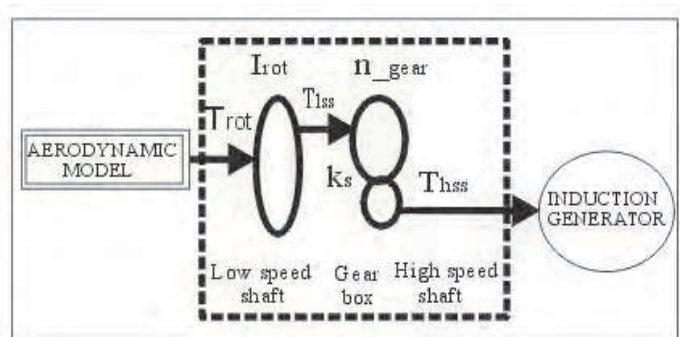

Fig. 4. Drive train model of the wind turbine.

#### 2.4 The induction generator model

The induction machine model is a combined mechanical and electro-magnetic model. The mechanical model includes the inertia of the generator rotor in the generator model.

Induction generators are 4/6 pole single cage machines (2MW/500kW) implemented using their nominal nameplate parameters.

The torque-slip and short-circuit test curves are used as a definition in the built-in DigSILENT asynchronous machine model.

Electrical parameter variations and different cage rotors with rotor displacement can also be considered (DigSILENT Power Factory user manual, 2010).

In the simulations presented in the following the induction generator is a single cage machines implemented using their nominal nameplate parameters, as can be seen in Fig. 5.

To wider the range of the output electrical power the generators are with double stator windings (2/0.5MW).

The switching between 4/6 pole operation is made as a function of output power.

#### 2.5 The soft-starter model

In order to reduce the transient current during connection of the induction generator to the grid a soft starter is used. The soft-starter could minimize the impact of machine starting on the electrical network and also could helps to prolong the life of mechanical components.

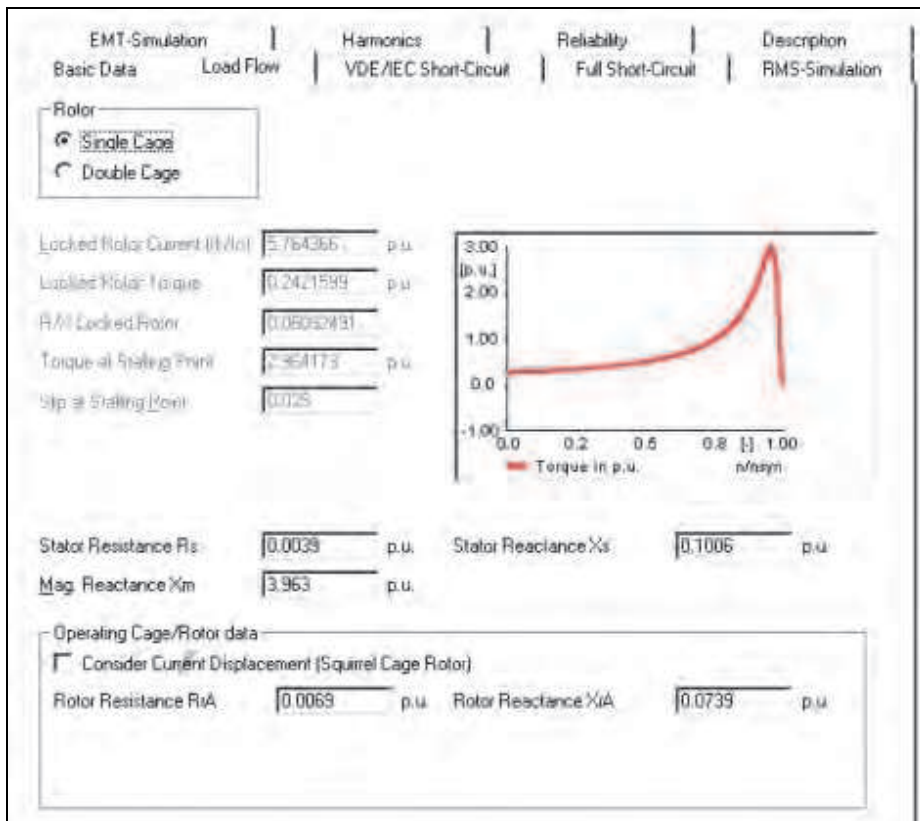

Fig. 5. Induction generator of 2 MW rating power implemented in Digsilent simulation tool based on its torque-slip curve and name plate values.

A soft-starter is an ac voltage controller in which the voltage is adjusted through the setting of the thyristors firing angle (Deleroi & Woudstra, 1991).

The soft-starter is designed to meet the industrial requirements of wind generator applications. In Digsilent Power Factory the soft starter is a stand-alone element. The commutation devices are 2 thyristors connected in anti-parallel for each phase.

The soft-starter modelling and its control implementation are described in details and a set of simulations are performed using Digsilent software simulation tool.

When the wind generator is driven to just below synchronous speed (approximately 93 %), under the action of its aerodynamic rotor, the soft starter is connected and using the firing angle control the machine is connected over the grid.

The connection diagram of soft starter fed a 4/6 poles double stator windings induction machine is presented in Fig. 6 a). Figure 6 b) shows the fully controlled topology with a delta-connected load. If thyristors are delta-connected, their control is simplified and their ratings considerably reduced. The delta arrangements generate, in the load, all the odd harmonics, but no triple harmonics. Harmonics of order 5, 7, 11, 13 ... remain.

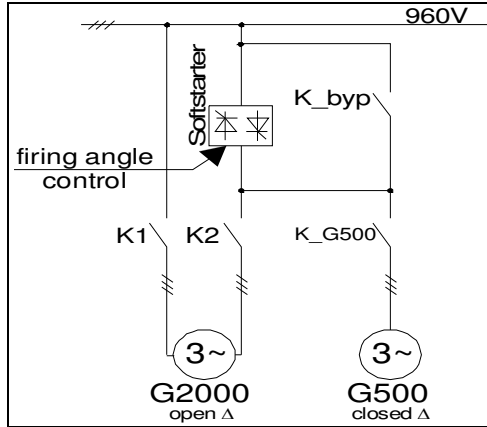

a)

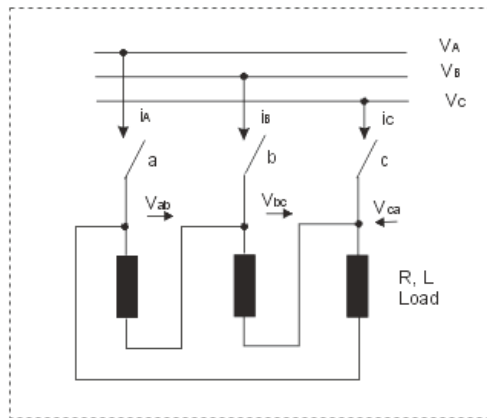

b)

Fig. 6. a) Connection diagram of the soft-starter with induction generators and schematic diagram of the soft-starter with delta connected load, b).

To get the controller started, two or three switches must be fired simultaneously to provide the path for current necessary to maintain the on-state. Switching variables may be introduced for 2 thyristors connected in anti-parallel for each phase and defined as equal to 1 when a given thyristor is conducting and equal to 0 otherwise. It can easily be demonstrated that the output voltages of the controller (soft-starter) are given by (6):

$$\begin{bmatrix} V_{ab} \\ V_{bc} \\ V_{ca} \end{bmatrix} = \begin{bmatrix} ab & -\frac{1}{2}a & -\frac{1}{2}b \\ -\frac{1}{2}c & bc & -\frac{1}{2}b \\ -\frac{1}{2}c & -\frac{1}{2}a & ca \end{bmatrix} \times \begin{bmatrix} V_{AB} \\ V_{BC} \\ V_{CA} \end{bmatrix} \tag{6}$$

Depending on the firing angle, three modes of operation of the soft-starter can be distinguished, with a purely resistive load (Rombaut, et. al, 1987):

1.  $0^\circ \leq \alpha < 60^\circ$  : 2 or 3 switches conducting (in either direction);
2.  $60^\circ \leq \alpha < 90^\circ$  : 2 switches conducting;
3.  $90^\circ \leq \alpha < 150^\circ$  : none or two switches conducting.

Analysis of operation of the controller with RL load is difficult since the extension angle and the so-called limit angle must be known. Mode 2, characterized by rapid changes of the output currents is impossible due to the load inductance. The ranges of the two remaining operation modes are  $\varphi \leq \alpha < \alpha_{lim}$  for mode 1 and  $\alpha_{lim} \leq \alpha < 150^\circ$  for mode 3. The limit angle can be determined numerically from (7):

$$\frac{\sin(\alpha_{lim} - \varphi - \frac{4}{3}\pi)}{\sin(\alpha_{lim} - \varphi)} = \frac{2e^{\frac{\pi}{3\lg(\varphi)}} - 1}{2 - e^{\frac{\pi}{3\lg(\varphi)}}} \quad (7)$$

The equations for the RMS output voltage, of the fully controlled soft-starter with purely resistive and inductive loads are provided below:

Resistive load:

$$V_{out} = V_{in} \cdot \sqrt{\frac{1}{\pi} \cdot \left[ \pi - \frac{3}{2} \cdot \alpha + \frac{3}{4} \sin(2\alpha) \right]} \quad (8)$$

for  $0^\circ \leq \alpha < 60^\circ$

$$V_{out} = V_{in} \cdot \sqrt{\frac{1}{\pi} \cdot \left[ \frac{\pi}{2} + \frac{3\sqrt{3}}{4} \cdot \sin(2\alpha + \frac{\pi}{6}) \right]} \quad (9)$$

for  $60^\circ \leq \alpha < 90^\circ$

$$V_{out} = V_{in} \cdot \sqrt{\frac{1}{\pi} \cdot \left[ \frac{5\pi}{4} - \frac{3}{2} \cdot \alpha + \frac{3}{4} \cdot \sin(2\alpha + \frac{\pi}{3}) \right]} \quad (10)$$

for  $90^\circ \leq \alpha < 150^\circ$

Inductive load

$$V_{out} = V_{in} \cdot \sqrt{\frac{1}{\pi} \cdot \left[ \frac{5\pi}{2} - 3\alpha + \frac{3}{2} \cdot \sin(2\alpha) \right]} \quad (11)$$

for  $90^\circ \leq \alpha < 120^\circ$

$$V_{out} = V_{in} \cdot \sqrt{\frac{1}{\pi} \cdot \left[ \frac{5\pi}{2} - 3\alpha + \frac{3}{2} \cdot \sin(2\alpha + \frac{\pi}{3}) \right]} \quad (12)$$

for  $120^\circ \leq \alpha < 150^\circ$

The envelope of control characteristics given by (8) through (12) is shown in Fig. 7. The relationship between the firing angle and the resulting amplification of the soft starter is



highly non-linear and depends additionally on the power factor of the connected element. In the case of a resistive load  $\alpha$  can vary between 0 (full on) and 90 (full off) degrees. While in the case of a purely inductive load  $\alpha$  varies between 90 (full on) and 180 (full off) degrees. For any power factor in between, it will be somewhere between these limits, as can also be seen in Fig. 7.

In DigSILENT the control parts (electrical controllers) of the wind turbine system, as the soft-starter control implementation, are written in the dynamic simulation language DSL. DSL implementation includes a complete mathematical description of (time-) continuous linear and nonlinear systems. A DSL model can also be converted into a graphical representation.

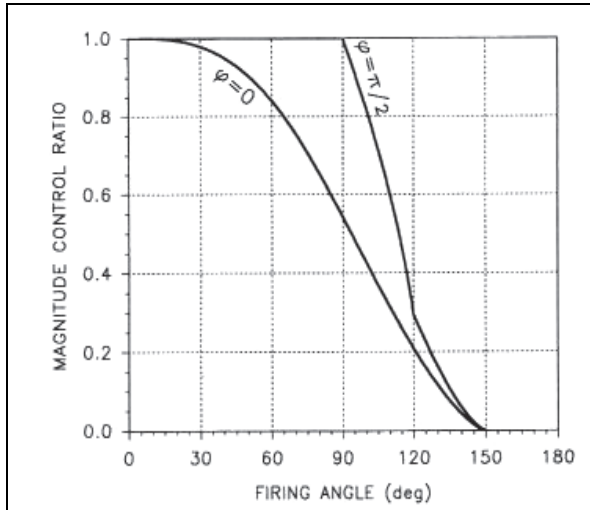

Fig. 7. Control characteristic,  $V_{out}=f(\alpha)$ , for a fully controlled soft-starter (Rombaut, 1987).

Fig. 8 shows the soft-starter composite model implemented in DigSILENT, in which “Control slot” represents the soft-starter controller while “Soft starter slot” is a block for checking the soft-starter state (working / bypassed).

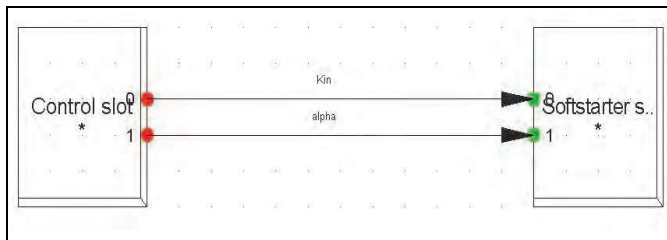

Fig. 8. Soft-starter composite model implemented in DigSILENT.

The firing angle ( $\alpha$ ) is calculated according to the amplification factor ( $K_{in}$ ) so that if  $K_{in}$  varies from 0 to 1,  $\alpha$  will take values starting from  $\alpha_1$  down to  $\alpha_2$ , (Mihet-Popa, L. et.al, 2008).

$$\alpha = \frac{\pi}{180^\circ} \cdot [a_2 + (a_2 - a_1) \cdot (K_{in} - 1)] \quad (13)$$

In which  $a_1$ ,  $a_2$ -maximum and minimum angles in degrees and  $a$ ,  $b$ ,  $c$ -switching variables for thyristors;

### 3. Control strategies for wind turbines

Wind turbines are designed to produce electrical energy as cheaply as possible. Therefore there are generally designed so that they yield maximum output power at wind speeds around (12-15) meters per second (Hansen, 2001).

In case of stronger winds it is necessary to waste a part of the excess energy of the wind in order to avoid damaging the wind turbine. All wind turbines are therefore designed with some sort of power control.

There are two different ways of doing this safely on modern wind turbines: pitch control and active stall control, as will be described as follows.

#### 3.1 Pitch controlled wind turbines

On a pitch controlled wind turbine the electronic controller checks the output power of the turbine several times per second. When the output power becomes too high, it sends an order to the blade pitch mechanism which immediately pitches (turns) the rotor blades slightly out of the wind. Conversely, the blades are turned back into the wind whenever the wind drops again. The rotor blades thus have to be able to turn around their longitudinal axis (to pitch). During normal operation the blades will pitch a fraction of a degree at a time - and the rotor will be turning at the same time. Designing a pitch-controlled wind turbine requires some clever engineering to make sure that the rotor blades pitch exactly the amount required. The pitch mechanism is usually operated using hydraulics or electric stepper motors (Heier, 1998 & Muljadi, 1999).

As with pitch control it is largely an economic question whether it is worthwhile to pay for the added complexity of the machine, when the blade pitch mechanism is added.

#### 3.2 Stall controlled wind turbines

Stall controlled (passive stall controlled) wind turbines have the rotor blades bolted onto the hub at a fixed angle. The geometry of the rotor blade profile however has been aerodynamically designed to ensure that the moment when the wind speed becomes too high ; it creates turbulence on the side of the rotor blade which is not facing the wind. This stall prevents the lifting force of the rotor blade from acting on the rotor. As the actual wind speed in the area increases, the angle of attack of the rotor blade will increase, until at some point it starts to stall. If you look closely at a rotor blade for a stall controlled wind turbine you will notice that the blade is twisted slightly as you move along its longitudinal axis. This is partly done in order to ensure that the rotor blade stalls gradually rather than abruptly when the wind speed reaches its critical value. The basic advantage of stall control is that one avoids moving parts in the rotor itself, and a complex control system (Mihet-Popa, L., 2003).

A normal passive-stall controlled wind turbine will usually have a drop in the electrical power output for higher wind speeds, as the rotor blades go into deeper stall. On the other hand, stall control represents a very complex aerodynamic design problem, and related

design challenges in the structural dynamics of the whole wind turbine, e.g. to avoid stall-induced vibrations.

### 3.3 Active stall controlled wind turbines

An increasing number of larger wind turbines (1 MW and more) are developed with an active stall power control mechanism. Technically the active stall turbines resemble pitch-controlled turbines, since they have pitch able blades. In order to get a reasonably large torque (turning force) at low wind speeds, the wind turbines will usually be programmed to pitch their blades much like a pitch controlled wind turbine at low wind speeds. Often they use only a few fixed steps depending upon the wind speed.

When the turbine reaches its rated power, however, it will notice an important difference from the pitch controlled wind turbines: If the generator is about to be overloaded, the turbine will pitch its blades in the opposite direction from what a pitch-controlled wind turbine does. In other words, it will increase the angle of attack of the rotor blades in order to make the blades go into a deeper stall, thus wasting the excess energy in the wind.

One of the advantages of active stall is that one can control the active power more accurately than with passive stall, so as to avoid overshooting the rated power of the turbine at the beginning of a gust of wind. Another advantage is that the wind generator can be run almost exactly at the rated power of the machine at all high wind speeds.

### 3.4 Rotor efficiency under stall and pitch controlled wind turbines

The output power of wind turbines varies with wind speed, but is not proportional to it, as the energy that the wind contains increases with the cube of the wind speed. At low wind speeds (1-3 m/s), wind turbines are shut down, as they would be able to generate little or no power (Fig. 9).

Wind turbines only start-up at wind speeds between 2.5 and 5 m/s, known as the “cut-in” wind speed. “Nominal” or “rated” wind speed, at which nominal output power is reached, is normally between 12 and 15 m/s. The precise value depends on the ratio of generator capacity to rotor surface area, and is a design variable. Finally, any wind turbine has a “cut-out wind speed”: this is the wind speed at which the turbine is shut down to avoid structural overload. Its value is around 25 m/s for IEC Wind class I and II turbines. For IEC Wind Class III turbines, which generate maximum output power at lower wind speeds, the cut-out value is in the range of 17-20 m/s. Wind turbines are shut down if the 10-minute average of the wind speed is above this design value. Below nominal wind speed, the aim is to maximize rotor efficiency (Fig. 9).

The rotor efficiency depends on the ratio of the rotor blade tip speed and wind speed, known as the “tip speed ratio” ( $\lambda$ ), described by:

$$\lambda = \omega_{rot} \cdot R / u_{eq} \quad (14)$$

The tip speed ratio of a fixed speed wind turbine cannot be controlled, as the rotor speed (and thus the blade tip speed) is fixed. Nevertheless, the tip speed ratio varies with wind speed, and thus reaches the optimum value at one wind speed only in case of fixed speed designs (or at two speeds if the wind turbine can operate at two different, but constant, rotor speeds).

With a variable speed wind turbine, the tip speed ratio varies, and depends both on wind speed and rotor speed. For maximum rotor efficiency, the tip speed ratio must be

maintained at the value that corresponds to optimum rotor efficiency (usually 6-9) at all times. This is achieved by controlling the rotor speed accordingly. The higher aerodynamic efficiency that is thus achieved explains why a variable speed turbine generates more energy for the same wind speed regime.

At wind speeds below nominal, the aim is to extract energy from the wind as efficiently as possible; however, this ceases to apply above nominal wind speed, as this would overload the generator and/or the converter system. Above nominal wind speed, therefore, the mechanical power extracted from the wind must remain constant. To achieve this, the aerodynamic rotor efficiency must be reduced when the wind speed increases, as can also be seen in Fig. 9.

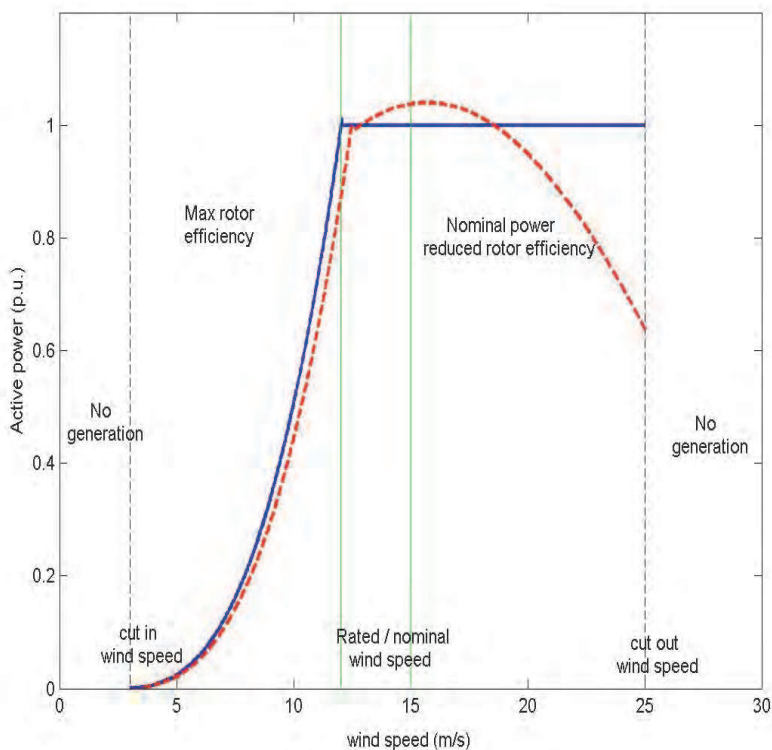

Fig. 9. Typical power curves and operation areas of a stall (dashed line) and pitch controlled (solid line) wind turbines.

In a stall controlled wind turbine, the blades are designed such that the rotor efficiency “collapses” at high wind speeds. Due to the blade design, this behaviour is intrinsic, and no active control systems are required to achieve the aerodynamic efficiency reduction. In a pitch controlled wind turbine, the blades are gradually turned out of the wind, so the wind impact angle changes and the aerodynamic efficiency is reduced. In this case active stall control is applied, by means of hydraulics or an electric drive system. The input variable for the pitch controller is the rotor speed, as it is depicted in Fig. 10.

The higher the rotor speed, the more the blades are turned out of the wind. The blades are turned back into the wind when the rotor speed falls. In general, fixed speed turbines use stall control for technical reasons, while variable speed turbines are usually equipped with pitch control.

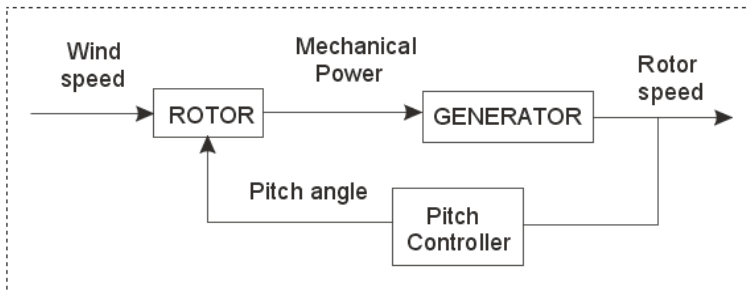

Fig. 10. Rotor speed control principle for wind speeds above nominal.

The active-stall concept is similar to normal stall power limitation, except that the whole blade can be rotated backwards (in the opposite direction as is the case with pitch control) by a few (3-5) degrees at the nominal speed range in order to give better rotor control. The application of this concept is more or less restricted to fixed speed turbines.

Typical active-stall representatives are the Danish manufacturers Bonus (1 MW and over) and NEG Micon (now Vestas) (1.5, 2 MW and over).

The difference from active pitch control is not only that the range of blade angle variation is less, but also that the direction of the variation is opposite.

### 3.5 Control design for an active-stall constant speed wind turbine

A common control concept for megawatt-size wind turbines/wind farms without power electronic converters is the active stall regulation. An active stall wind turbine is a stall controlled turbine with variable pitch angle. At high wind speeds, the pitch angle is adjusted to obtain the desired rated power level. When connecting the wind generator to the grid, the pitch angle is also adjusted in order to obtain a smooth connection. The use of active stall control also facilitates the emergency stopping of the turbine.

The control strategy called active-stall constant-speed involves the combined interaction between wind model, pitch control and the aerodynamics of the wind turbine, as can be seen in Fig. 11.

The blade angle control block models the active-stall control of the wind turbine based on the measured power and the reference one (Sorensen, P. et.al, 2001).

The most used electrical generator of an active-stall constant-speed turbine is a cage rotor induction generator connected to the grid through a soft-starter, as it is shown in Fig. 11.

A clear difference between stall and active stall controlled wind turbines is a pitch actuator system for variable pitch angles, as can be seen in Fig. 12, which allows the stall effect to be controlled.

The model of the pitch control system is based on the measured generator power ( $P_m$ ) and the aerodynamic power ( $P_{aero}$ ) of wind turbine as a function of measured wind speed ( $v_{wind}$ ) at different pitch angles ( $\theta$ ).

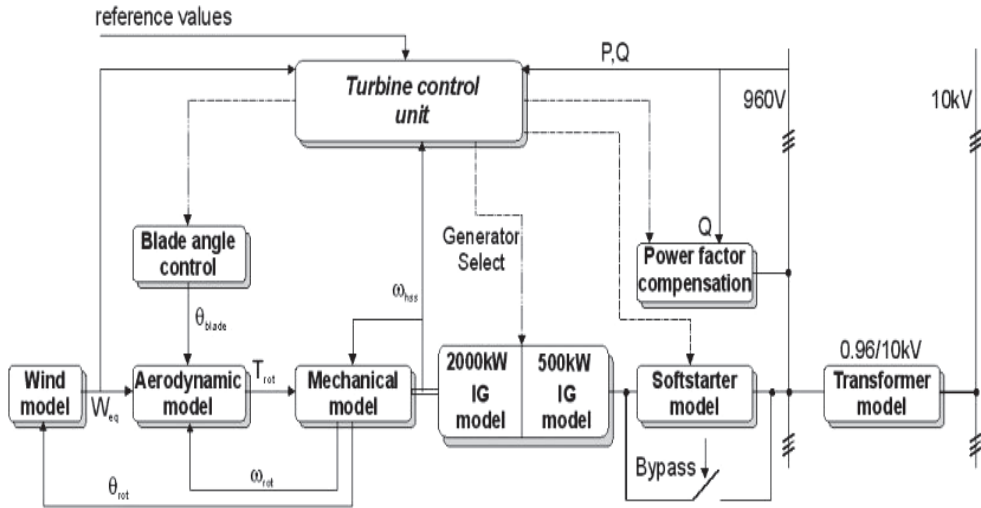

Fig. 11. Block diagram of an active-stall controlled wind turbine with constant speed using a cage-rotor induction generator

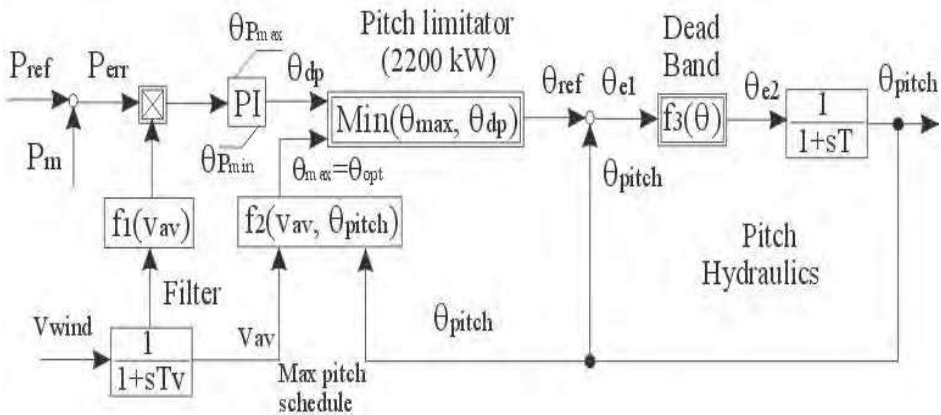

Fig. 12. The block diagram of blade pitch angle control system.

The measured power is compared with its reference ( $P_{ref}$ ) and the error signal ( $P_{err}$ ) multiplied by pitch angle of power control ( $f_1(v_{av})$ ) is sent to the PI-controller producing the pitch angle demand ( $\theta_{dp}$ ), which together with maximum pitch angle-upper limit ( $\theta_{max}$ ) are sent to the pitch limitation non-linear block producing the reference value of the pitch angle ( $\theta_{ref}$ ). The reference value is in the range between the optimised pitch ( $\theta_{dp}$ ) and the maximal pitch angle ( $\theta_{max}=90^\circ$ ). The maximum value is defined as a function of average wind speed

$(f_z(v_{av}))$ . The reference value is, further, compared to the actual pitch angle ( $\theta_{pitch}$ ) and the error signal ( $\theta_{e2}$ ) is corrected by the pitch hydraulics.

This control strategy takes its origin in the power coefficient curves  $C_p(\theta, u)$ , typical for a 2 MW constant speed wind turbine, as it is depicted in Fig. 13.

$C_p$  represents the rotor (aerodynamic) efficiency of the wind turbine and depends on the pitch angle  $\theta$  and on the tip speed ratio  $\lambda$ . In order to achieve maximum power yield for each wind speed the maximal  $C_p$  and the corresponding  $\theta$  has to be found.

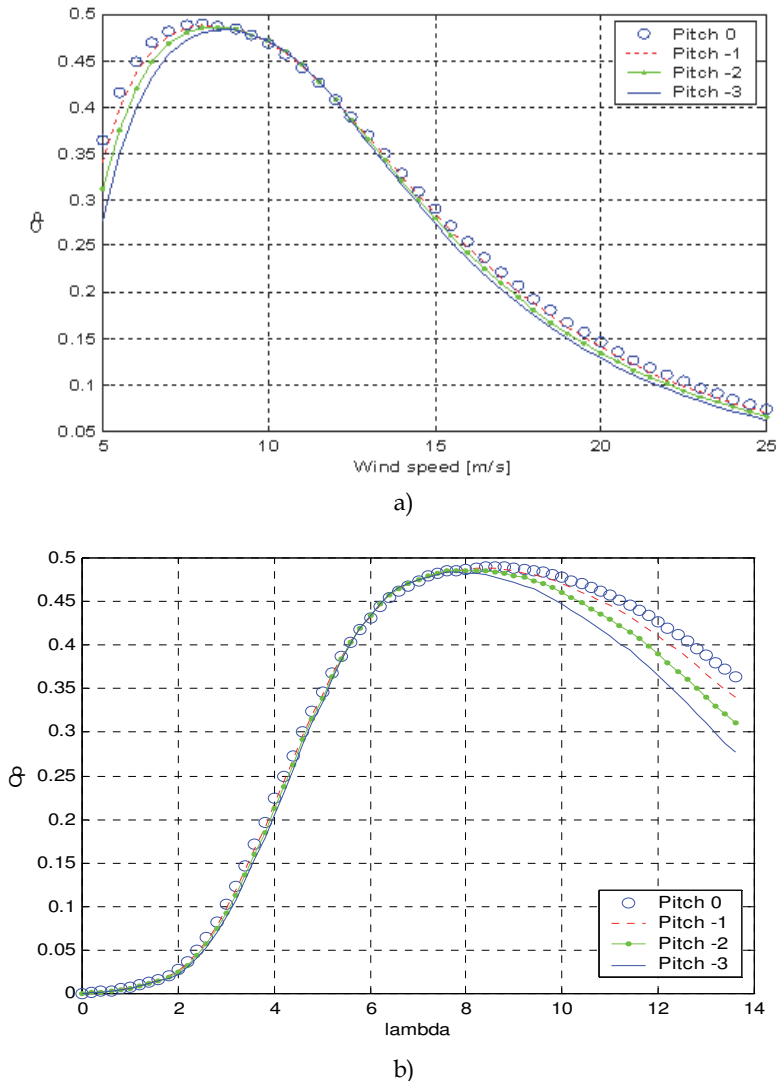

Fig. 13. Power coefficient ( $C_p$ ) of a 2MW wind turbine versus wind speed (a), and the tip speed ratio ( $\lambda$ ), (b) at different pitch angles.

In order to achieve maximum power yield for each wind speed the maximal  $C_p$  and the corresponding  $\theta$  has to be found. In fact, the control strategy is characterised by two terms: the optimal region and the power limiting region. In the optimal region (between start-up wind speed and nominal wind speed), the output power is designed to fulfil the criterion of maximal  $C_p$ , which corresponds to the optimal energy capture, by keeping the tip speed ratio ( $\lambda$ ) constant. In the power limiting region (between nominal wind speed and cut-out wind speed), the output power is kept constant, while the wind turbine will pitch the blades a few degrees every time when the wind changes in order to keep the rotor blades at the optimum angle. When the wind turbine reaches its rated power, and the generator is about to be overloaded, the turbine will pitch its blades in the opposite direction. In this way, it will increase the angle of attack of the rotor blades in order to make the blades go into a deeper stall, thus wasting the excess energy in the wind.

#### 4. Wind farm modelling

The wind farm contains 6 wind turbines of 2 MW each of them. The model of wind turbine, presented before, was implemented for each wind turbine.

The layout of the active-stall wind farm is shown in Fig. 14 and a load flow simulation for one wind turbine in Fig. 15. Each wind turbine is connected to a 10 kV bus bar. The induction generators, soft-starters, capacitor banks for reactive power compensation and the step-up transformers are all placed in nacelle and thus the transformer is considered part of the wind turbine.

The control of active and reactive power is based on measured reactive power at the point of common coupling. The wind turbine controller must be able to adjust the wind turbine production to the power reference computed in the wind farm control system, according to the demands imposed by the system operator. In case of normal operation conditions the wind turbine has to produce maximum power. In power limitation operation mode the wind turbine has to limit its production to the power reference received from the wind farm controller.

##### 4.1 Electrical diagram

The Fig. 14 contains the grid representation from 50 kV double bus-bar systems down to the wind turbines. Two 16 MVA 50/10kV transformers are included, one is connected to the wind farm and one supplies some custom loads.

10 kV cables make the connection between the 10 kV substation and the wind turbines.

As the turbines are placed in groups of 3, a backup cable is also represented on the scheme. The wind turbine contains also the tower cable making the connection between the 0.96 kV/10 kV transformer and the 10 kV cable at the bottom of the tower. The 10 kV cables are modelled using the existing DIGSILENT model toolbox.

The power factor compensation units are represented by a capacitor bank on this scheme and a Static VAR System (SVS) unit. The switching of capacitors is done as a function of average value of measured reactive power. In order to limit the starting current transients during the 2 MW generator connections to the grid, a soft starter start-up is used. The generators are connected when the generator speed is higher than the synchronous speed. The generators are full load compensated.



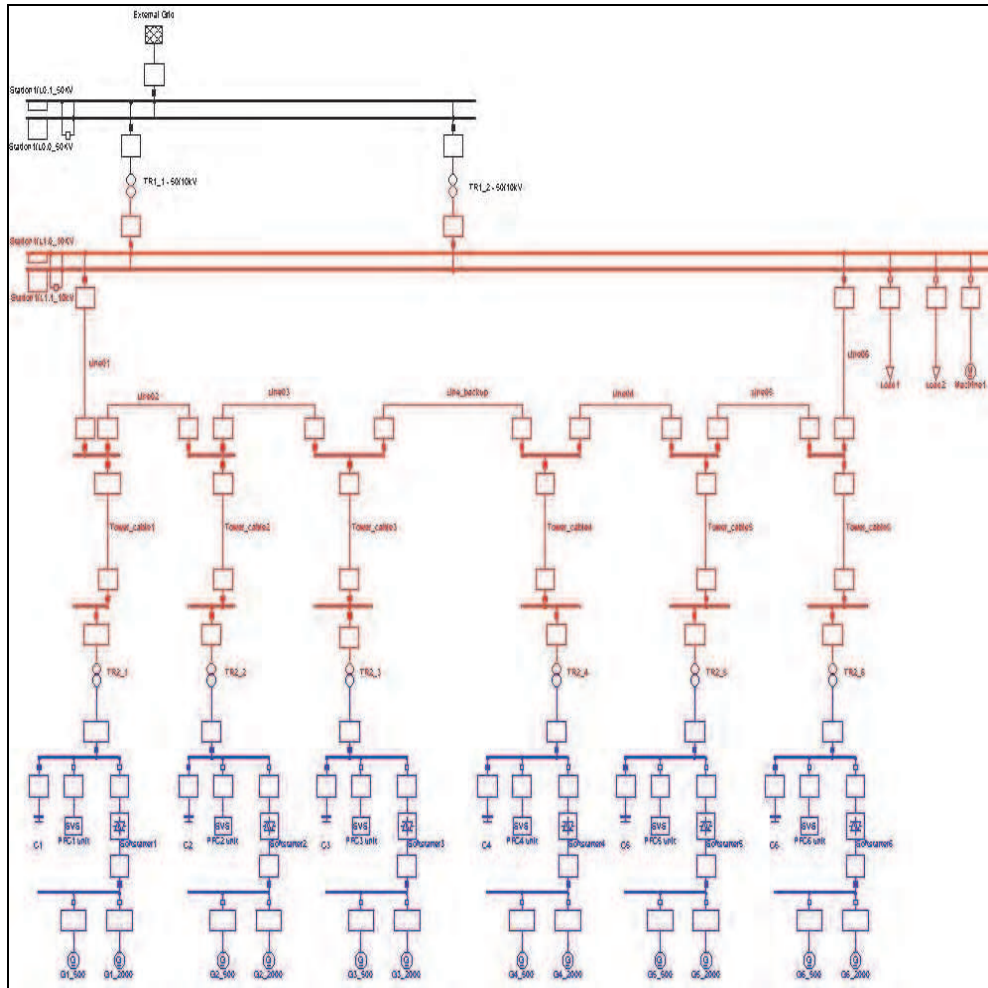

Fig. 14. 12 MW wind farm diagram implemented in Digsilent.

**4.2 Load flow simulation**

In Fig. 15 is depicted a case of load flow simulation when the wind turbines are work at nominal conditions (2MW) and full power factor compensation is used.

**5. Simulation results**

To evaluate the performance of wind turbine control system a set of simulations are performed using a power system analysis software-DigSILENT Power Factory, which provides the ability to simulate load flow, RMS fluctuations and transient events in the same software environment. This makes the developed models useful for the power quality studies as well as for the grid fault studies. The RMS simulations are based on

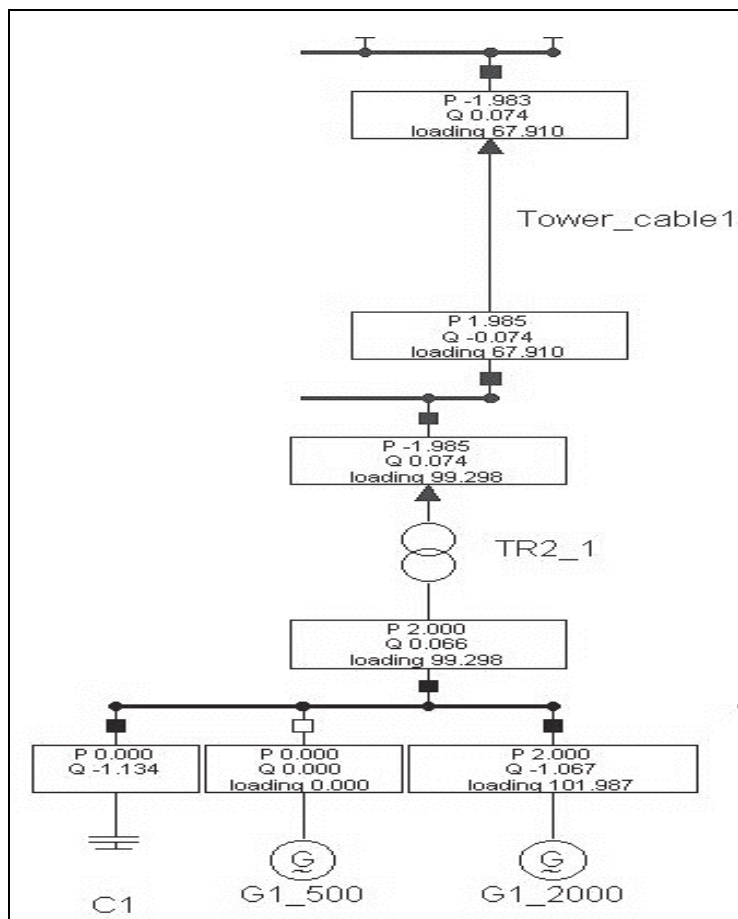

Fig. 15. Power-flow simulation for a wind turbine working at nominal conditions.

electro-mechanical transient models, which are simplified models than those used in EMT simulations. They are more appropriate for the most studies of power quality and control issues. They are much faster than the instantaneous value simulation compared to the period, which is simulated. The EMT simulations, as they are based on detailed electromagnetic transient models, are appropriate for studies of the behaviour during grid faults.

### 5.1 DigSILENT power factory software tool

To simulate the wind turbines, models have been developed for each element and implemented in the dedicated power system simulation tool DigSILENT (DigSILENT Power Factory user manual, 2010). The DigSILENT simulation tool has a dedicated model for many components, such as induction generators, which take into account the current displacements in the rotor, the torque-slip and short circuit test curves. Also models of synchronous machines, transformers, bus bars, grid models, static converters etc are provided.

### 5.2 Transmission model simulation during start-up

The aerodynamic torque (torque\_rot- $T_{rot}$ ) accelerates the wind turbine rotor, with the generator disconnected from the grid, until the rotor speed ( $\omega_{rot}$ ) is close to its nominal value. Then the generator is connected to the grid as seen in Fig. 16. The basic idea is to control the rotational speed using only measurement of the power (or torque), as it is depicted in Fig. 1 and by equations (1) and (2) as well.

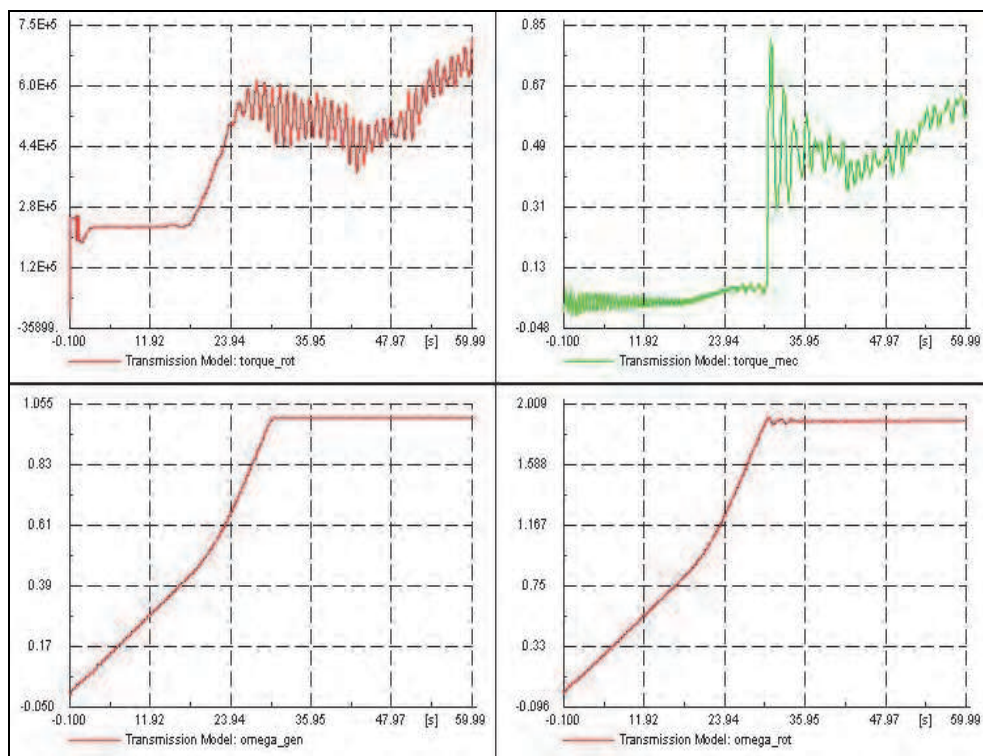

Fig. 16. Transmission model during start-up. Aerodynamic torque (torque\_rot), mechanical torque (torque\_mec), generator speed (omega\_gen) and rotor speed (omega\_rot) of wind turbine system.

### 5.3 Simulation results during start-up, normal operation and heavy transients

The control strategy of active stall constant speed wind turbine contains three modes of operation: acceleration control (speed control), power control (power limiting region) and direct pitch control (blade angle control).

The acceleration and pitch control modes are used during start-up, shut down and emergency conditions, while the power control mode is only used during normal operations.

Figure 17 shows how a 2 MW wind turbine with constant speed works during different operation conditions, such as sudden changes in wind speed (wind gusts) with a turbulence intensity of 12 %, at high wind speed.

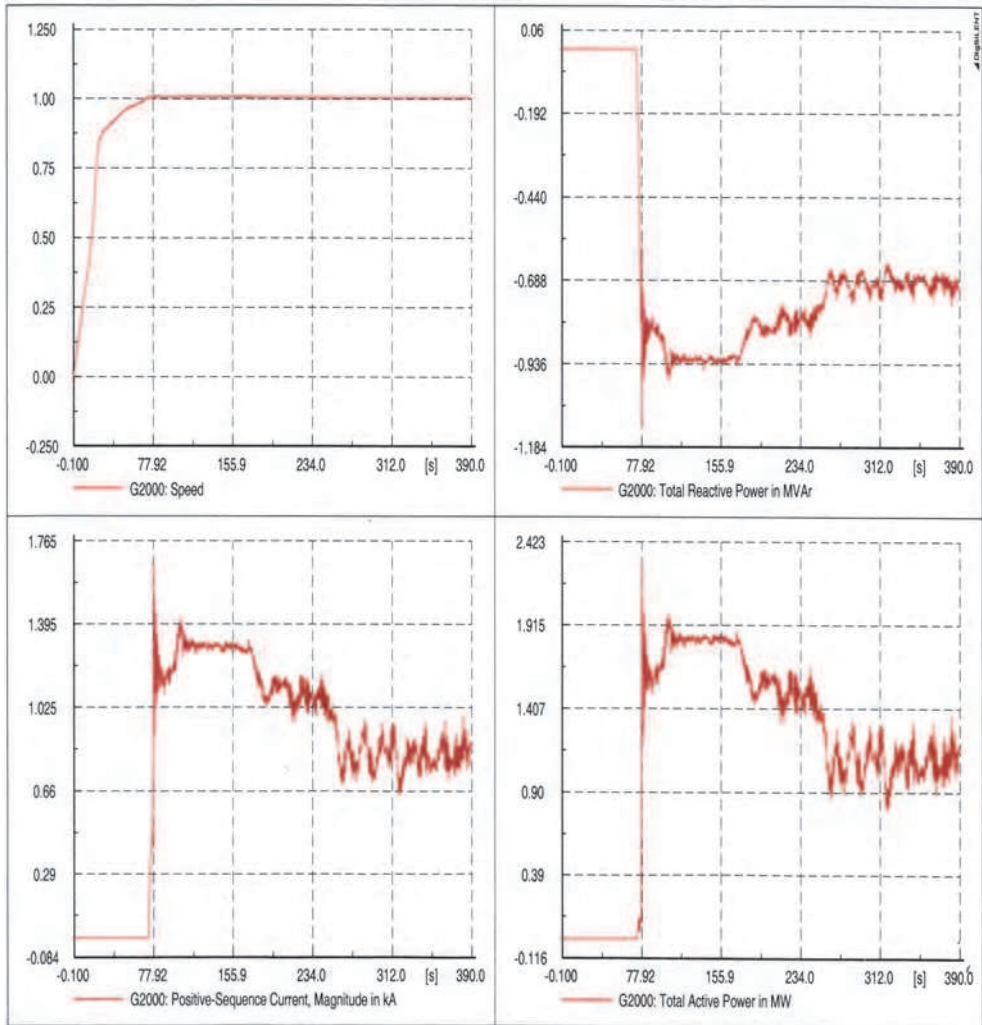

Fig. 17. Simulation results during sudden changes in wind speed for a 2MW active stall constant-speed wind turbine using CRIG.

In Fig. 18 the 2 MW induction generator was connected to the grid through a soft-starter (in order to reduce the transient current), at  $t=73$  seconds and then the soft-starter was bypassed at  $t=77$  seconds.

In the same time the power factor compensation unit started to work using capacitor switching, as a function of average value of measured reactive power.

The mean wind speed was 12 m/s. At  $t=100$  seconds the mean wind speed was modified to 18 (m/s) and at  $t=170$  seconds mean wind speed was modified again at 11 (m/s) to simulate sudden changes in wind speed and to test the system performance and implemented control strategy, as it is also shown in Fig. 17.

The active and reactive powers have been able to follow these changes in all situations. It is concluded that the wind turbine absorbed the transients very fast and the control strategy offers a good stability of the system during transition of dynamic changes.

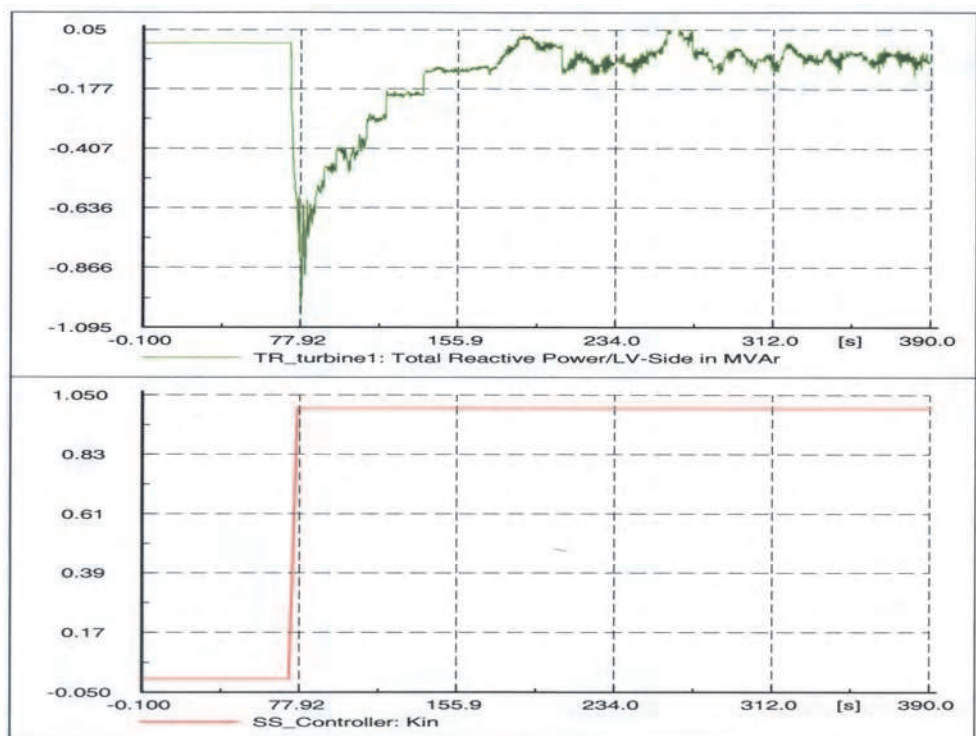
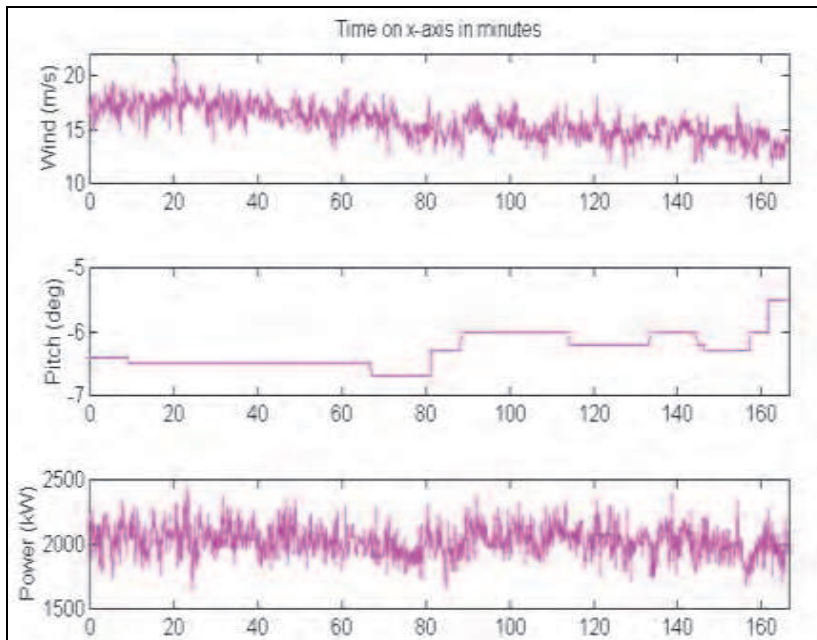

Fig. 18. Reactive power compensation with capacitors connected in steps (on top) and the soft-starter by-passed controller (SS\_controller:  $K_{IN}$ ).

## 6. Comparison between measurements and simulation results

The comparison between simulations and measurements will be done to validate the developed model. It is performed for the case of continuous operation, and is based on power quality measurements for a 2 MW wind turbine from an existing wind farm in Denmark. The wind speed measurement was provided by the anemometer of the control system placed on the top of the nacelle and the power quality measurements were performed as sampling of instantaneous values of three-phase currents and voltages with a sampling frequency of 3.2 kHz, as shown in Fig. 19a).

Fig. 19 presents a comparison between measured (Fig. 19a) and simulated (Fig. 19b) of wind speed, pitch angle and active power of a 2 MW WT under power control mode. The power control mode is used during normal operations. It is clear that at high wind speed (around 18 m/s), using the active stall regulation, the pitch angle is continuously adjusted to obtain the desired rated power level (2 MW).



a)

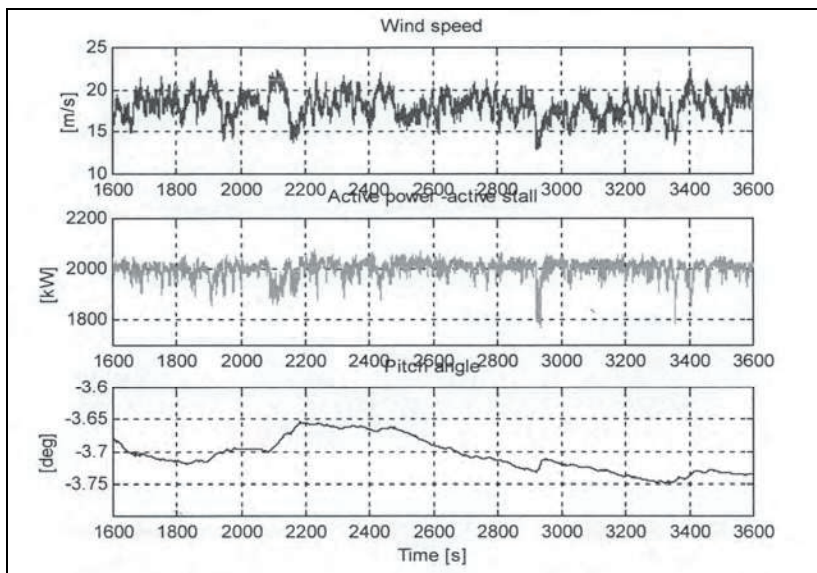

b)

Fig. 19. Power control mode of a 2 MW active-stall constant speed WT. Measured wind speed and active power under pitch control regulated during 170 minutes (a) and simulation of wind speed, active power and pitch angle versus time (b).

## 7. Discussion and conclusion

In this paper simulation of a 6 x 2 MW wind turbine plant (wind farm) has been presented. A wind farm model has been built to simulate the influence on the transient stability of power systems. The model of each wind turbine includes the wind fluctuation model, which will make the model useful also to simulate the power quality and to study control strategies of a wind turbine.

The control scheme has been developed for each wind turbine control including soft starter start-up, and power factor compensation.

The above presented model can be a useful tool for wind power industry to study the behaviour and influence of big wind turbines (wind farm) in the distribution network.

The computer simulations prove to be a valuable tool in predicting the system behaviour. Especially in wind power applications, DiGSILENT Power Factory has become the de-facto standard tool, as all required models and simulation algorithms are providing unmet accuracy and performance.

One future research step is to investigate and enhance the controller's capabilities to handle grid faults. Another interesting issue is to explore the present controllers in the design of a whole wind farm and the connection of the wind farm at different types of grid and storage systems.

## 8. Acknowledgment

This work was carried out with the support of Aalborg University-Denmark. I would like to thank Professor Frede Blaabjerg for his suggestions and useful discussions.

## 9. References

- Deleroi W. and Woudstra J.B. (1991), Connecting an asynchronous generator on the grid using a thyristor switch, *IEEE Transactions on Industry Applications*, Vol. 2, pp. 55-60. <http://www.digsilent.de> DiGSILENT Power Factory user manuals (2010), DiGSILENT GmbH, Germany. <http://www.gwec.com>. Gary-Williams Energy Corporation (GWEC, 2009).
- Hansen A.D., Sorensen P., Janosi L. & Bech J. (2001). *Proceedings of IECON*, Vol.3, No.4, pp. 1959-1964, ISSN 1729-8806;
- Hansen A.D., Jauch C., Sorensen P., Iov F. & Blaabjerg F. Dynamic Wind Turbine Models in Power System Simulation Tool DiGSILENT, *Research Report of Riso-R-1400(EN)* National Laboratory, Roskilde, December 2003, ISBN 87-550-3198-6;
- Hansen L.H., Helle L., Blaabjerg F., Ritchie E., Munk-Nielsen S., Bidner H., Sorensen P. and Bak-Jensen B. (2001), *Conceptual survey of generators and power electronics for wind turbines*, Riso-R-1205 (EN);
- Heier S. (1998). *Wind Energy Conversion Systems*, John Wiley & Sons Inc., ISBN 0-471-971-43, New York, USA ;
- Mihet-Popa L. (2003). *Wind Turbines using Induction Generators connected to the Grid*, Ph. D. Thesis, POLITEHNICA University of Timisoara-Romania, October 2003, ISBN 978-973-625-533-5;
- Mihet-Popa L., Blaabjerg F. and Boldea I. (2004), Wind Turbine Generator Modeling and Simulation where Rotational Speed is the Controlled Variable, *IEEE-IAS*

- Transactions on Energy Conversion*, January / February 2004, Vol. 40, No. 1, pp. 3-10, ISSN: 0093-9994;
- Mihet-Popa L. and Boldea I. (2006), Dynamics of control strategies for wind turbine applications, *the 10th International Conference on Optimisation of Electrical and Electronic Equipment, OPTIM 2006*, May 18-19, Poiana Brasov, Vol. 2, pp. 199-206;
- Mihet-Popa L., Proștean O. and Szeidert I. (2008), The soft-starters modeling, simulations and control implementation for 2 MW constant-speed wind turbines, *The International Review of Electrical Engineering – IREE*, Vol. 3, No. 1, January-February 2008, pp. 129-135, ISSN: 1827-6660;
- Mihet-Popa L. and Groza V. (2010), Modeling and simulations of a 12 MW wind farm, *Journal of Advances in Electrical and Computer Engineering*, Vol. 10, No. 2, 2010, pp. 141-144, ISSN 1582-7445;
- Mihet-Popa L. and Pacas J.M. (2005), Active stall constant speed wind turbine during transient grid fault events and sudden changes in wind speed, *Proceedings of International Exhibition & Conference for Power Electronics Intelligent Motion Power Quality, 26th International PCIM Conference*, Nuremberg, 7-9 June, pp. 646-65;
- Muljadi, E.; Butterfield, Pitch-controlled variable-speed wind turbine generation, *Industry Applications Conference, 1999. IAS Annual Meeting*. Conference Record, Vol. 1, pp 323-330.
- Petru, T. & Thiringer T. (2002), Modeling of Wind Turbines for Power System Studies, *IEEE Trans. On Power Systems*, Vol. 17, No. 4, Nov. 2002, pp. 1132 - 1139.
- Rombaut, C; Segulier, G. and Bausiere, R.; *Power Electronic Converters-AC/AC Conversion* (New York; McGraw-Hill, 1987).
- Slootweg, J.G. & Kling, W.L. (2002). Modeling and Analysing Impacts of Wind Power on Transient Stability of Power Systems, *International Journal of Wind Engineering*, Vol. 26, No. 1, pp. 3-20;
- Sorensen P., Hansen A.D., Thomsen K., Buhl T., Morthorst P.E., Nielsen L.H., Iov F., Blaabjerg F., Nielsen H.A., Madsen H. and Donovan M.H. (2005), *Operation and Control of Large Wind Turbines and Wind Farms*, Riso Research Report-R-1532 (EN), Riso National Laboratory of Denmark-Roskilde;





## **Wind Farm - Impact in Power System and Alternatives to Improve the Integration**

Edited by Dr. Gastn Orlando Suvire

ISBN 978-953-307-467-2

Hard cover, 330 pages

**Publisher** InTech

**Published online** 28, July, 2011

**Published in print edition** July, 2011

During the last two decades, increase in electricity demand and environmental concern resulted in fast growth of power production from renewable sources. Wind power is one of the most efficient alternatives. Due to rapid development of wind turbine technology and increasing size of wind farms, wind power plays a significant part in the power production in some countries. However, fundamental differences exist between conventional thermal, hydro, and nuclear generation and wind power, such as different generation systems and the difficulty in controlling the primary movement of a wind turbine, due to the wind and its random fluctuations. These differences are reflected in the specific interaction of wind turbines with the power system. This book addresses a wide variety of issues regarding the integration of wind farms in power systems. The book contains 14 chapters divided into three parts. The first part outlines aspects related to the impact of the wind power generation on the electric system. In the second part, alternatives to mitigate problems of the wind farm integration are presented. Finally, the third part covers issues of modeling and simulation of wind power system.

### **How to reference**

In order to correctly reference this scholarly work, feel free to copy and paste the following:

Lucian Mihet-Popa and Voicu Groza (2011). Modeling and Simulation of a 12 MW Active-Stall Constant-Speed Wind Farm, *Wind Farm - Impact in Power System and Alternatives to Improve the Integration*, Dr. Gastn Orlando Suvire (Ed.), ISBN: 978-953-307-467-2, InTech, Available from:

<http://www.intechopen.com/books/wind-farm-impact-in-power-system-and-alternatives-to-improve-the-integration/modeling-and-simulation-of-a-12-mw-active-stall-constant-speed-wind-farm>

**INTECH**  
open science | open minds

### **InTech Europe**

University Campus STeP Ri  
Slavka Krautzeka 83/A  
51000 Rijeka, Croatia  
Phone: +385 (51) 770 447  
Fax: +385 (51) 686 166  
[www.intechopen.com](http://www.intechopen.com)

### **InTech China**

Unit 405, Office Block, Hotel Equatorial Shanghai  
No.65, Yan An Road (West), Shanghai, 200040, China  
中国上海市延安西路65号上海国际贵都大饭店办公楼405单元  
Phone: +86-21-62489820  
Fax: +86-21-62489821

© 2011 The Author(s). Licensee IntechOpen. This chapter is distributed under the terms of the [Creative Commons Attribution-NonCommercial-ShareAlike-3.0 License](#), which permits use, distribution and reproduction for non-commercial purposes, provided the original is properly cited and derivative works building on this content are distributed under the same license.