

Development Liquid Rocket Engine of Small Thrust With Combustion Chamber from Carbon - Ceramic Composite Material

Alexander A. Kozlov¹, Aleksey G. Vorobiev²,
Igor N. Borovik³, Ivan S. Kazennov⁴, Anton V. Lahin⁵,
Eugenie A. Bogachev⁶ and Anatoly N. Timofeev⁷
^{1,2,3,4}MAI
^{5,6,7}«Kompozit» corporation
Russia

1. Introduction

Advances in the development of high-temperature composite materials and coatings based on glass and ceramics were the basis for their application in aerospace and other branches of engineering. Carbon-ceramic composite materials (CCCM) have unique heat-shielding, erosion-resistant performance and durability at a low density.

At present, composite material used as protective coatings of elements of aircraft gas turbine engines, turbopump assembly of liquid rocket engines, hypersonic technology products, tile protection of spacecraft, inserts the nozzle into a block of solid fuel engines and other technical fields, where the most acute problem of protection structure at high temperature in an oxidizing environment.

In the MAI at the department #202 investigations in the development of small rocket engine thrusts. Ability to use CCCM as a material of the combustion chamber is considered as one of the most promising ways to improve small engines thrusts.

2. Overview of problems and problem statement

Intention to apply the composite material (CM) to create a combustion chamber LRE of small thrust (LREST) associated with essential growth engine specific impulse, which characterizes its effectiveness. The first attempts to introduce carbon-carbon composites as a material for the combustion chamber LREST undertaken in the early-middle of the last decade [6]. However, the resulting designs are generally not meet one or more of the requirements for chamber LREST. Addressing the application of CM based on the following tasks:

- availability of technology forming a thin-walled shell profile, characteristic of combustion chamber of LREST;
- protect material from a high temperature in an oxidizing environment possible conditions;
- develop design a secure connection composite combustion chamber with metal mixing head;

- ensure zero gas-tightness of the wall;
- the possibility of mechanical machining of parts from CM;
- ensuring the strength of the material with a sharp change in pressure and the presence of thermal stresses, typical for pulsed operation of LREST.

As a result of the development and improvement of production technology CM related to the choice of optimal process parameters, the technical level of equipment and tooling availability of reliable methods for nondestructive testing of composite structures and semi-finished products for their production, managed to develop a scientific basis and the basis for developing an extensive list of composite materials and technologies of their production [1]. Currently, there are all prerequisites for a successful practical application CCCM as a material for LREST.

Long time the main materials used for combustion chamber of LREST in Russia and other country were niobium alloys with protective silicide coating. They are able to withstand temperatures up to 1200°C, although the temperature of the combustion products can reach 3,500°C. To reduce the temperature of the wall of the combustion chamber the mixing fuel and oxidizer is organized with sub-optimal ratio of components. This reduces fuel efficiency, which in general is reflected in the perfection of the aircraft. Russian serial thruster (KBHM, Engineering Research Institute) and currently as the main material used alloys based on niobium. To date, the value of specific impulse for Russian LREST on the components of the nitrogen tetroxide (NTO) + unsymmetrical dimethylhydrazine (UDMH) / monometilgidrazin (MMG) is less than 310 (1, 2).

Foreign LREST as the material of the combustion chamber and the nozzle using alloys based on niobium (engine TR-308, TR-312-100MN, Northrop Grumman) (LEROS 1R, LEROS 1C American Pacific Corporation, AMPAC, USA), platinum (S400 - 12, S400 - 15, EADS Astrium, Europe), iridium (engines R-4D, R-4D-15 (HiPAT) (Fig. 3), Aerojet, USA) with protective coatings. To reduce temperature effects on the wall using the hanging film. Operating temperature chamber walls with precious metals of platinum may reach 2200 ° C. Specific impulse of modern foreign engine components NTO + UDMH / MMG) reaches 327 sec.

With the advent of composite materials that are not inferior in its characteristics, but at a price much cheaper than the above alloys, foreign manufacturers have switched to the development of the combustion chambers LREST with the CM. The use of non-metallic composite is promising, because, being comparable in price to conventional niobium alloys, it has a lower density, which is important in terms of reducing the mass of the engine, a substantially lower cost compared to the platinum group metals.

In Russia, the issues involved in the development of KM "Kompozit" [9], VIAM [7, 8], Company "Iskra" and several other organizations. In Russia the use of KM in rocket engines is reduced to the use of CCC for the attachment of radiative cooling of the engine 11D58M, but understanding the prospects for the application of CM in the elements of missile technology exists [4].

Abroad, there are many organizations dealing with composite materials (ULTRAMet, SNECMA, DuPont). In some countries there is a separate program for the development of aerospace industry with abroad application of advanced CM. Some foreign developers LREST already implementing the combustion chamber of CM in their propulsion systems.

One example of successful introduction of advanced composite technology is the development corporation EADS apogee thruster, called the European Apogee Motor. Engine European Apogee Motor, thrust 500N, in which the combustion chamber and nozzle are made at the same time (4, 5), is lightweight and high specific impulse, which amounts

to more than 325 seconds [10]. European Apogee Motor will be the main engine for the platform AlphaBus.

Along with the progressive combustion chamber from CM, which can resist high temperatures, vibration and shock loads, to achieve this level of specific impulse possible to optimize the mixing head.

Various methods of nondestructive testing have been investigated and applied, including ultrasound, thermography and tomography. European Apogee Motor can be used for various tasks in the commercial and military satellites, Transfer Vehicle, vehicles reusable. Low weight and high specific engine performance save fuel, which positively affects the value of the payload in comparison with other engines. Reasonable price of production and procurement composite material allows the engine to compete successfully in the market.

Features LREST domestic and foreign production with the designation of the material used are given in Table 1.



Fig. 1. Engine KBChM DST-100A



Fig. 2. Engine Engineering Research Institute 11D428A

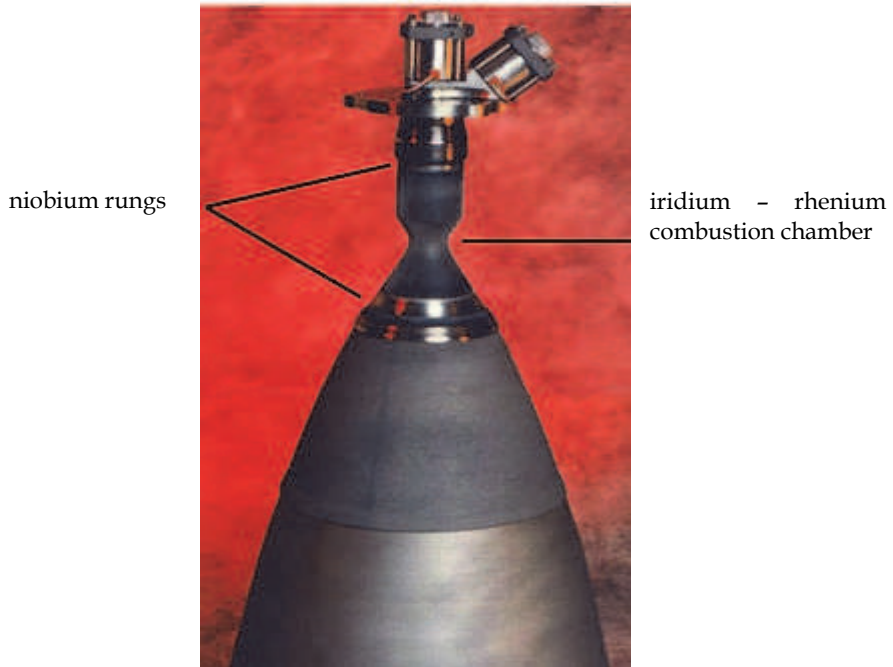

Fig. 3. Engine HiPAT with c iridium- rhenium combustion chamber.



Fig. 4. Combustion chamber and nozzle of European Apogee Motor.



Fig. 5. Engine European Apogee Motor

	11D428A NIIMash (Russia)	11D458M NIIMash (Russia)	DST- 200A KMChM (Russia)	S400 - 15 EADS	R-4D-15 (HiPAT) Aerojet	500 H European Apogee Motor
Components:	UDMH NTO	UDMH NTO	UDMH NTO	MMG NTO, MON-1, MON-3	NTO MMG	MMH, NTO, MON-1, MON-3
Vacuum thrust (N):	130,5	392.4	200	425	445	500 +/- 20N
Vacuum specific impulse (sec):	308	302	307	321	325	>/= 325 sec
O/F:	1,85±0,05	1,85±0,05	1.85	1.65	1	1.65
Pressure chamber (bar):			7	10	9.4	10
Valve current (V)	27	27	34			50
Length (mm)	274	461		669		803
Weigh (kg):	1.5	3	1.7	4.3	5.2	< 5
Expansion ratio	150		100		300	
Combustion chamber material	Niobium alloy	Niobium alloy	Niobium alloy	Platinum alloy	Iridium alloy with rhenium coating	Composite material

Table 1. LREST performance.

Thus, in terms of technology development of production structures made of composite materials, an effort the developers of space vehicles and platforms to increase the mass of the payload, the task of creating the combustion chamber of LREST from carbon-ceramic material is urgent.

3. Development of the COP from KM to LREST MAI-202

202 Department of the Moscow Aviation Institute has long been working in the design and creation of experimental LREST [3, 11, 12]. On this subject holds a number of contracts, some contracts are in work. The construction mixer head engines LREST MAI-202 is the use of separate plates welded together the components and the presence of low-pressure film cooling layer with the ability to regulate its relative expense.

The main LREST for which is developed by the combustion chamber from CM are the engines: MAI-202-200 thrust of 200 N on the components of the NTO + UDMH (fuel film cooling), MAI-202-500-HTHP-Kerosene thrust 500 N on the components of high tests hydrogen peroxide (96%) + kerosene (oxidizer film cooling), MAI -202-200-Oxygen-Kerosene thrust of 200 N on the components of gaseous oxygen and kerosene (oxidizer film cooling). The expansion ratio for all engines 70, the pressure in the combustion chamber 9-12 atm.

To reduce the cost of production engines combustion chamber were made of heat resistant alloy EP-202 and HN60VT with protective antioxidant coating based on chromium oxide. Maximum temperature of the wall of the combustion chamber in the tests did not exceed 1200 K.

As a result of cooperation with NPO "Kompozit", on the basis of the developers at that time, technology for the production of similar products [9, 5] have developed a program to develop the experimental combustion chambers of ceramic based composite material for the above engines.

Table 2 shows the characteristics of the developed material CCCM C-SiC for the combustion chamber of LRE compared with traditional materials - niobium alloys 5VMTS and similar materials C-SiC, used in non-Russian LREST.

NPO "Kompozit" has several recipes and opportunities for applying the method of oxide coatings on the surface CCCM nanotechnology to improve the radiating capacity of the outer wall of the chamber and the reflectivity of the inner wall. These activities are aimed at raising the temperature boundary layer of combustion products without increasing the wall temperature of the combustion chamber.

Parameters	Performance		
	LREST of dep. 202 MAI	Russian engines	Foreign engines
	Combustion chamber from CM C-SiC	Serial combustion chamber from alloy 5VMC with disilicide molybdenum coating	Novoltex C-SiC-, (SNECMA, France)
Working temperature, °C	1600	1450	1600
Density, gr/cm ³	1,75	~ 8,7	2,1
Combustion chamber weigh decreasing, %	300-400	-	300

Table 2. Comparison of characteristics of the developed material for the COP LREST with the characteristics of traditional material and foreign analogues

The technology of obtaining ceramic combustion chambers clean, does not require large expenditures for tooling and expensive manufacturing equipment, unlike their foreign counterparts. Method of forming a matrix does not introduce damage in the reinforcing components. Reagent has not previously been used for construction and materials and protective coatings.

The existing technology of the matrix provides the opportunity to connect with the metal wingtips - flanges due to the formation of metal-composite junction, which gives a strongtight ceramic-composite mount the camera to the metal parts of the engine - mixing head and nozzle attachment.

In the design (Fig. 6) new combustion chambers, the following conditions:

- preservation of the internal geometric profile of the combustion chamber and the nozzle;

- the availability of ready-mixing heads of the engines;
- conservation sectional design of the engine in the main parts (heads, the combustion chamber, the nozzle attachment) for testing individual units with the possibility of not folding design;
- the ability to install fittings for measuring pressure in the combustion chamber when developing a workflow.

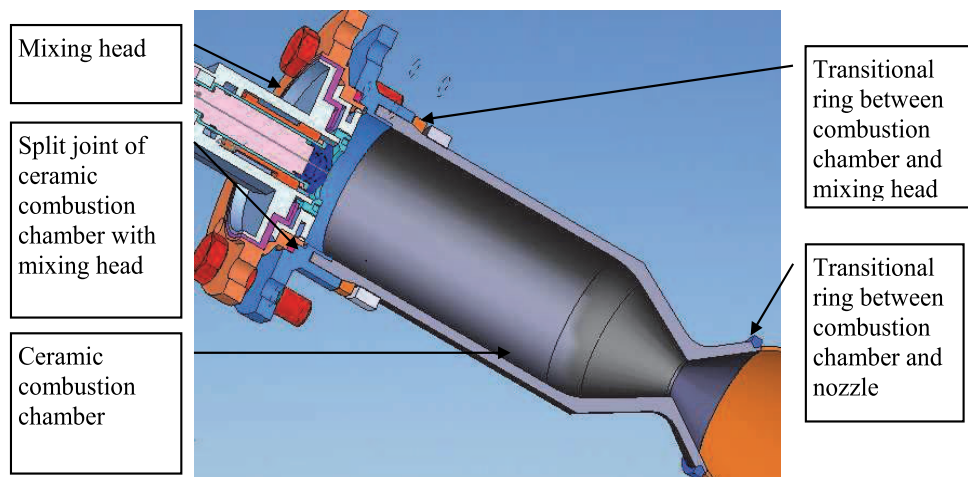

Fig. 6. Model LREST MAI-202-200-Oxygen-Kerosene with the composite combustion chamber

The samples of the combustion chambers (Fig. 7) underwent the following operations:

- formation of carbon fiber frame blanks;
- pre-machining;
- carbonation and high-temperature treatment;
- formation of silicon carbide matrix by chemical vapor saturation;
- forming a composite coating for gas isolation.

As a result, studies were identified and addressed a number of problems:

- improving technology, laying patterns to create a complex profile of the combustion chamber with small diametral dimensions of the throat;
- designed connectors connect the camera to the mixing head and nozzle of the heat-resistant steel.

Currently, new engines with the designation of MAI-202C, where the letter C means the application ceramic composition combustion chamber (Fig. 8), in preparation for firing tests.

In addition to weight reduction designs and improve specific impulse by raising the temperature of combustion products, the use of composite materials with an antioxidant coating will in future go to oxidative veil of low-flow that will positively affect the efficiency of the engine.



Fig. 7. Work material of ceramic combustion chamber.

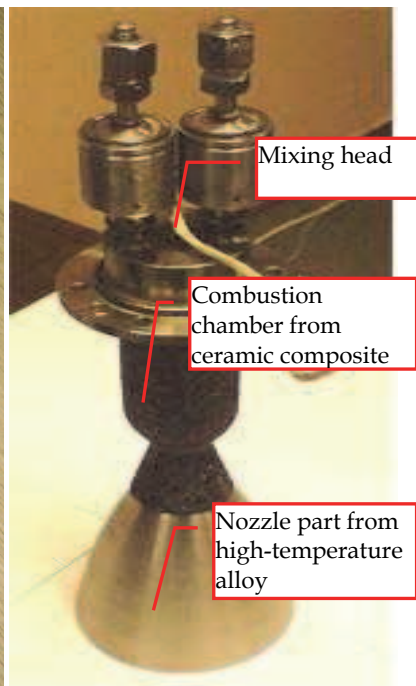

Fig. 8. Model of LREST MAI-202-200-OK.

4. Analysis of the efficacy of CM for the combustion chambers LREST

By raising the temperature of combustion products and the operating temperature of the walls of the combustion chamber due to changes in mixing and reduce the consumption component in the veil is possible to obtain high specific impulse in the application of CM in the construction of the combustion chamber.

On the basis of firing experiments on the engine MAI-202-200 (NTO UDMH) [11] analysis was conducted to increase the specific impulse in the case of the combustion chamber of CM [2]. The calculations for the experimental-theoretical model of thermalstate LREST it was shown that the use of new material for the engine MAI-202-200, operating at 1800 K allows to achieve a specific impulse of 325 sec. and for the engine MAI-202-500-HTHPK specific impulse will be 326 seconds. that at the world's leading manufacturers LREST (Fig. 9, Fig. 10).

The calculation results show that increasing the specific impulse apogee LREST for 5 seconds increases the weight of the payload of 7 kg for the model geostationary satellite weighing 4800 kg, equivalent can be replaced by extending the life of the device [13]. A more detailed analysis of the gain in weight of the payload from an increase in specific impulse LREST requires binding to a specific machine.

For engines MAI-202-200, MAI-202-500K-HTHPK preparing fire tests to assess their energy efficiency with ceramic composition of the combustion chamber. Also planned for the study of composite combustion chamber engines MAI-202 with pulse mode operation to prove the efficiency of the material under cyclic thermal and mechanical stresses.

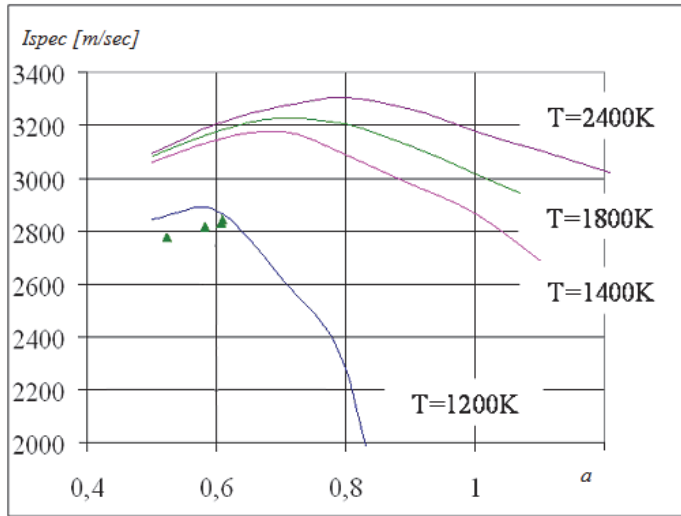

Fig. 9. Calculated dependence of the pulse motor MAI-202-200 depending on the coefficient of oxidizer for different maximum wall temperature of the combustion chamber (for the single-injector head). Green triangles - experimental data/

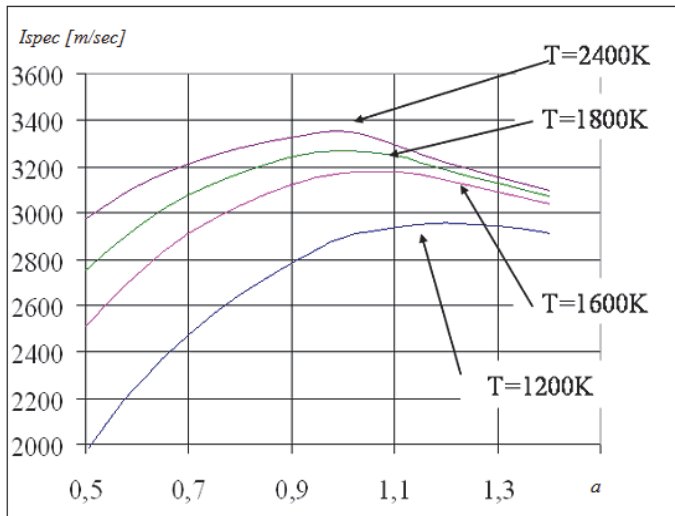

Fig. 10. Calculated dependence of the pulse motor MAI-202-500-VPVK depending on the coefficient of excess oxidizer for different maximum wall temperature of the combustion chamber.

5. Conclusions

At the Department of MAI 202 together with "Kompozite" is under active development of small rocket engines with thrust combustion chambers of the carbon-ceramic composite

materials. The analysis shows that the use of CM achieves a specific impulse in excess of Russian flight models, and corresponding foreign equivalents developed. Detailed information can be found at www.mai202.ru.

6. References

- [1] Буланов И.М., Воробей В.В. Технология ракетных и аэрокосмических конструкций из композиционных материалов: Учеб. для вузов. М.: Изд-во МГТУ им. Н.Э.Баумана, 1998, 516 с.
- [2] Воробьев А.Г. Математическая модель теплового состояния ЖРДМТ. Вестник МАИ. Т14, №4. Москва. 2007. – С. 42-49.
- [3] Козлов А.А., Абашев В.М. Расчет и проектирование жидкостного ракетного двигателя малой тяги. Москва, МАИ, 2006.
- [4] Кошлаков В.В., Миронов В.В. Перспективы применения композиционных материалов в ракетных двигателях. Ракетно-космические двигательные установки: сборник материалов Всероссийской научно-технической конференции. М.: Изд-во МГТУ имени Н.Э. Баумана, 2008. – 10-11 с.
- [5] Лахин А.В. Процессы получения композиционных материалов и покрытий на основе карбида кремния химическим газофазным осаждением из метилсилана при относительно низких температурах и давлениях: Дис. канд. наук. – Москва, 2006. – 140 с.
- [6] Павлов С.В., Грачев В.Д., Токарев А.С. Результаты разработки и исследований работоспособности камер сгорания ЖРДМТ из УУКМ // Ракетно-космическая техника, вып. 3 (136). НИИ тепловых процессов, 1992 г. 30-33 с.
- [7] Солнцев С.С., Исаева Н.В. Керамический композиционный материал теплонагруженных узлов и деталей. Первый межведомственный научно-технический семинар по проблемам низкоэмиссионных камер сгорания газотурбинных установок. Опыт разработки, проблемы создания и перспективы развития низкоэмиссионных камер сгорания ГТУ. 14-16 декабря. Москва, ЦИАМ
- [8] Солнцев С.С. Высокотемпературные керамические композиционные материалы и антиокислительные ресурсные покрытия. // 75 лет. Авиационные материалы. Избранные труды «ВИАМ» 1932-2007. Под ред. Каблова Е.Н. – М.: «ВИАМ», 2007. – 438 с.
- [9] Тимофеев А.Н., Богачев Е.А., Габов А.В., Абызов А.М., Смирнов Е.П., Персин М.И. Способ получения композиционного материала. – Патент РФ №2130509 от 20.05.1999, приоритет от 26.01.1998.
- [10] Astrium.EADS Web Page: <http://cs.astrium.eads.net/sp/SpacecraftPropulsion/BipropellantThrusters.html>
- [11] Kozlov A.A., Abashev V.M., Denisov K.P. etc. Experimental finishing of bipropellant apogee engine with thrust 200 N. 51st International Astronautical Congress. Rio de Janeiro, Brazil. October 2-6, 2000.
- [12] Kozlov A.A., Abashev V.M., Hinckel J.N. Organization of the working process in the small thrust engine LRESTH MAI-200. 52nd International Astronautical Congress. Toulouse, France. October 1-5, 2001.
- [13] Liou, Larry, C. Advanced Chemical Propulsion for Science Missions. NASA/TM-2008-215069.



Nanocomposites with Unique Properties and Applications in Medicine and Industry

Edited by Dr. John Cuppoletti

ISBN 978-953-307-351-4

Hard cover, 360 pages

Publisher InTech

Published online 23, August, 2011

Published in print edition August, 2011

This book contains chapters on nanocomposites for engineering hard materials for high performance aircraft, rocket and automobile use, using laser pulses to form metal coatings on glass and quartz, and also tungsten carbide-cobalt nanoparticles using high voltage discharges. A major section of this book is largely devoted to chapters outlining and applying analytic methods needed for studies of nanocomposites. As such, this book will serve as good resource for such analytic methods.

How to reference

In order to correctly reference this scholarly work, feel free to copy and paste the following:

Alexander A. Kozlov, Aleksey G. Vorobiev, Igor N. Borovik, Ivan S. Kazennov, Anton V. Lahin, Eugenie A. Bogachev and Anatoly N. Timofeev (2011). Development Liquid Rocket Engine of Small Thrust With Combustion Chamber from Carbon - Ceramic Composite Material, Nanocomposites with Unique Properties and Applications in Medicine and Industry, Dr. John Cuppoletti (Ed.), ISBN: 978-953-307-351-4, InTech, Available from: <http://www.intechopen.com/books/nanocomposites-with-unique-properties-and-applications-in-medicine-and-industry/development-liquid-rocket-engine-of-small-thrust-with-combustion-chamber-from-carbon-ceramic-composi>

INTECH
open science | open minds

InTech Europe

University Campus STeP Ri
Slavka Krautzeka 83/A
51000 Rijeka, Croatia
Phone: +385 (51) 770 447
Fax: +385 (51) 686 166
www.intechopen.com

InTech China

Unit 405, Office Block, Hotel Equatorial Shanghai
No.65, Yan An Road (West), Shanghai, 200040, China
中国上海市延安西路65号上海国际贵都大饭店办公楼405单元
Phone: +86-21-62489820
Fax: +86-21-62489821

© 2011 The Author(s). Licensee IntechOpen. This chapter is distributed under the terms of the [Creative Commons Attribution-NonCommercial-ShareAlike-3.0 License](#), which permits use, distribution and reproduction for non-commercial purposes, provided the original is properly cited and derivative works building on this content are distributed under the same license.