

Wind Farms and Grid Codes

María Paz Comech, Miguel García-Gracia, Susana Martín Arroyo and
Miguel Ángel Martínez Guillén
CIRCE-University of Zaragoza
Spain

1. Introduction

All customers connected to a public electricity network, whether generators or consumers, must comply with agreed technical requirements. Electric networks rely on generators to provide many of the control functions, and so the technical requirements for generators are unavoidably more complex than for demand customers. These technical requirements are termed 'Grid Codes'.

The technical requirements governing the relationship between generators and system operators need to be clearly defined. The introduction of renewable generation has often complicated this process significantly, as these generators have physical characteristics that are different from the directly connected synchronous generators used in large conventional power plants. In some countries, a specific grid code has been developed for wind farms, and in others the aim has been to define the requirements as far as possible in a way which is independent of the power plant technology.

The technical requirements within grid codes and related documents vary between electricity systems. However, for simplicity the typical requirements for generators can be grouped as follows:

- Tolerance - the range of conditions on the electricity system for which wind farms must continue to operate;
- Control of reactive power - often this includes requirements to contribute to voltage control on the network;
- Control of active power - often this includes requirements to contribute to frequency control on the network;
- Protective devices; and
- Power quality.

It is important to note that these requirements are often specified at the Point of Common Coupling (PCC) between the wind farm and the electricity network. In this case, the requirements are placed at wind farm level, and wind turbines may be adapted to meet these requirements. It is also possible for some requirements to be met by providing additional equipment, as for example for FACTS devices.

One of these new connection requirements regarding wind energy is fault ride-through capability. In the past, wind generators were not allowed to remain connected to the utility when voltage at the PCC fell below 85 %, forcing their disconnection even when the fault happened far from the wind farm (Jauch et al, 2007; Rodriguez et al, 2002). That is the reason

why, in grids with significant wind energy penetration, the voltage dip and the subsequent wind farm disconnections would create an important stability problem.

Therefore, it is important to check the compliance with Grid Codes. The Spanish Wind Energy Association has developed the document "Procedure for Verification Validation and Certification of the Requirements of the OP 12.3 on the Response of Wind Farms in the Event of Voltage Dips (PVVC) (AEE, 2007), and the German Fördergesellschaft Windenergie und andere Erneuerbare Energien the document "Technical Guidelines for Power Generating Units. Part 8. Certification of the electrical characteristics of power generating units and systems in the medium-, high- and highest-voltage grids" (FGW-TG8) (FGW, 2009) that describes the procedures to certify wind power installations according their corresponding Grid Codes.

The Compliance with Grid Codes can be checked by means of in-field test or by simulation of validated models. This chapter describes the procedure to verify wind installations according PVVC and FGW-TG8. Section 2 lists the most outstanding international Grid Codes, section 3 describes the fault ride through solutions of the different wind turbine types. Section 4 describes the fault ride through certification procedure, section 5 the voltage dip test, section 6 the model validation according to PVVC and FGW-TG8. Section 7 the wind farm verification according to PVVC.

2. International grid code requirements

Wind farms should contribute to power system control (voltage and frequency) and also to the electricity network recover in case of networks faults such as voltage dips or swells.

In the most cases a wind turbine should work with a power factor of 0.90 lagging to 0.95 leading and the frequency should situate within the range from 47.5 Hz to 52 Hz.

The most outstanding international Grid Codes are the following:

- USA FERC: "Interconnection for Wind Energy" 18 CFR Part 35 (Docket No. RM05-4-001; Order No. 661-A), Issued December 12, 2005 and "Interconnection Requirements for a Wind Generating Plant", Appendix G to the LGIA.
- Germany – E.ON Netz GmbH: "Grid Code - High and extra high voltage", Status: 1.April 2006.
- China – CEPRI: "Technical Rule for Connecting Wind Farm to Power System", December, 2005.
- Spain – REE – P.O. 12.3: Resolución de 4 de octubre de 2006, de la Secretaría General de Energía por la que se aprueba el procedimiento de operación 12.3 "Requisitos de respuesta frente a huecos de tensión de las instalaciones eólicas". Publicación en BOE núm. 254 de fecha 24 Octubre 2006.
- India – ISTS: "Indian Electricity Grid Code (IEGC)", April, 2006 and "Draft Report on Indian Wind Grid Code", July, 2009.
- France: "Décret no 2008-386 du 23 avril 2008 relatif aux prescriptions techniques générales de conception et de fonctionnement pour le raccordement d'installations de production aux réseaux publics d'électricité", April, 2008.
- Italy: "CEI 11-32; V1 Impianti di produzione eolica", December, 2006.
- Great Britain – National Grid Electricity Transmission plc: "The Grid Code", Issue 4 Revision 3, 6th September 2010.
- Denmark – ELKRAFT SYSTEM and ELTRA: "Wind Turbines Connected to Grids with Voltages above 100 kV - Technical regulations for the properties and the regulation of wind turbines", Regulation TF 3.2.5, December 3, 2004.

- Portugal – REN: Portaria n.º 596/2010 de 30 de Julho
- Canada – AESO: “Wind Power Facility - Technical Requirements”, Revision 0, November, 15 2004.
- Australia – AEMC: “National Electricity Rules (NER)”, Version 39, 16 September 2010
- Ireland – EIRGRID: “WFPS1- Controllable Wind Farm Power Station Grid Code Provisions”, EirGrid Grid Code, Version 3.4, October 16th 2009.

Fault ride through requirements are described by a voltage vs. time characteristic, denoting the minimum required immunity of the wind power station. The fault ride through requirements also include fast active and reactive power restoration to the prefault values, after the system voltage returns to normal operation levels. Some codes impose increased reactive power generation by the wind turbines during the disturbance, in order to provide voltage support, a requirement that resembles the behaviour of conventional synchronous generators in over-excited operation.

Fig. 1 presents in the same graph the fault ride through requirements from the different Grid Codes. These requirements depend on the specific characteristics of each power system and the protection employed and they deviate significantly from each other.

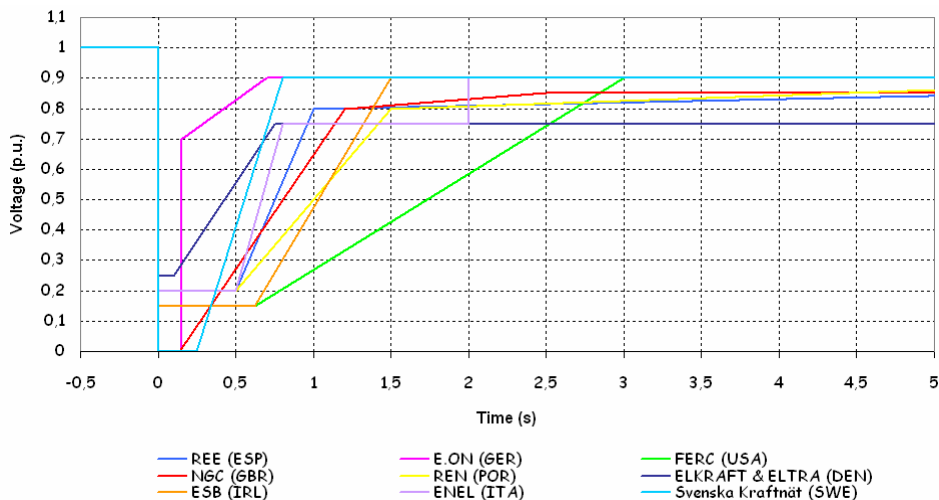

Fig. 1. Fault ride through requirements.

3. Wind turbine fault-ride through

As it has been said, one of the main problems for power quality are voltage dips. Due to high renewable penetration level in transmission system, Transmission System Operators (TSO) demand to this sort of energy source support voltage under voltage sags. This obligation has provoked a huge investment in devices to support wind systems during voltage dips.

Fig. 2 shows the three main technologies in the wind turbine industry. Their behaviour is different in continuous operation and during voltage dips.

Fig. 2a shows the fixed-speed wind turbine with asynchronous squirrel cage induction generator (SCIG) directly connected to the grid via transformer. Fig. 2b represents the

limited variable speed wind turbine with a wound rotor induction generator and partial scale frequency converter on the rotor circuit known as doubly fed induction generator (DFIG). Fig. 2c shows the full variable speed wind turbine, with the generator connected to the grid through a full-scale frequency converter.

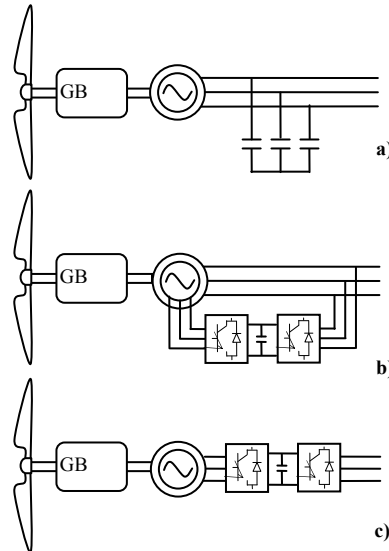

Fig. 2. Wind turbine technologies.

DFIG stator is connected directly to the network but its rotor is connected to the network by means of a power converter which performs the active and reactive power control. A voltage dip will cause large currents in the rotor of the DFIG to which the power electronic converter is connected, and a high rotor voltage will be needed to control the rotor current. When this required voltage exceeds the maximum voltage of the converter, it is not possible any longer to control the current desired (Morren, de Haan, 2007). This implies that large current can flow, which can destroy the converter.

In order to avoid breakdown of the converter switches, new DFIG wind turbines are provided with a system called crowbar connected to the rotor circuit. When the rotor currents become too high, the converter is disconnected and the high currents do not flow through the converter but rather into the crowbar resistances. The generator then operates as an induction machine with a high rotor resistance. When the dip lasts longer than a few hundreds of milliseconds ($T_{max_crowbar}$), the wind turbine can even support the grid during the dip (Morren, de Haan, 2007; López et al, 2009).

The full converted wind turbine is connected to the network through a converter; and therefore the converter controls the wind turbine during the dip in order to fulfill the Grid Code Requirements.

SCIG are used as fixed speed wind generator due to its superior characteristics such as brushless and rugged construction, low cost, maintenance free, and operational simplicity. However it requires large reactive power to recover the airgap flux when a short circuit occurs in the power system, unless otherwise the induction generator becomes unstable due

to the large difference between electromagnetic and mechanical torques, and then it requires to be disconnected from the power system (Muyeen et al, 2009; Muyeen & Takahashi, 2010). Next section describes different solutions to support the transient behaviour of SCIG and old DFIG wind turbines that do not fulfill fault ride through requirements.

3.1 Fault ride through solutions

Nowadays, the rapid development of power electronics has made that the old devices for controlling voltage based on capacitors and reactors have been replaced by Flexible AC Transmission Systems (FACTS).

New wind turbines have integrated different systems to withstand voltage dips; however the old wind turbines have to install different FACTS to overcome dips. The main solutions are installed either in each turbine or in the point of common coupling.

The FACTS used in wind systems can be divided into three categories depending on their connection (Amaris, 2007; Hingorain, 1999):

- Series device, for example the Dynamic Voltage Restorer (DVR)
- Shunt device, such as Static Voltage Compensator (SVC) and Static Compensator (STATCOM).
- Series-shunt device. They are a combination of a series and a parallel FACTS. In wind system Unified Power-Quality Conditioner (UPQC) are used.

Next, these systems are explained.

3.1.1 Static Voltage Compensator (SVC)

Static Voltage Compensator is a shunt-connected var generator or absorber whose output is adjusted to exchange capacitive or inductive current. Fig. 3 shows the connection of SVC. It is usually connected between the utility and the generator. SVC can provide reactive power, from 0 to 1 p.u. depending on voltage (Fig. 3). These devices use electronic switches as thyristor, which can open or close in few milliseconds. SVC is considered by some as a lower cost alternative to STATCOM, although this may not be the case if the comparison is made based on the required performance and not just in the MVA size, because for the same contingency and the same system, the required SVC ratings is generally larger than required STATCOM (Hingorain, 1999, Molinas et al, 2008).

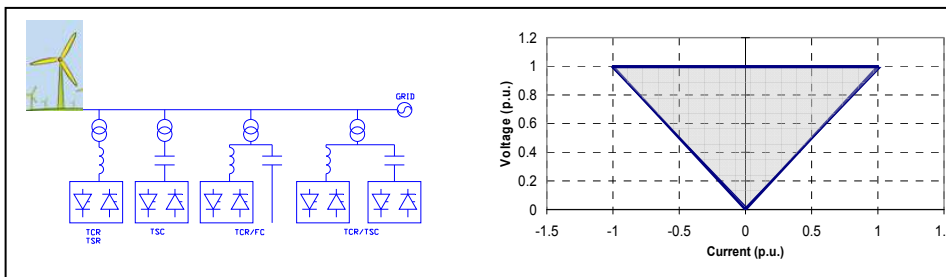

Fig. 3. Different topologies of SVC and V-I characteristic.

3.1.2 Static Synchronous Compensator (STATCOM)

Static Synchronous Compensator is a voltage source converter which can inject or absorb reactive current in an AC system, modifying the power flow. STATCOM can provide

reactive power independently of the voltage, as shown the voltage-current characteristic in Fig. 4. It comprises a converter, connected in parallel between utility and the generator, and a DC current stage as it is shown in Fig. 4.

STATCOM is the evolution of SVC, but STATCOM have continuous control and can compensate both power factor and voltage simultaneously. Other advantage of STATCOM is its dynamic capacity getting small response times.

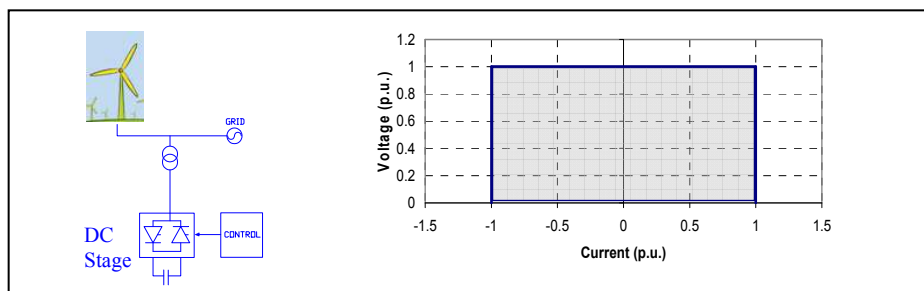

Fig. 4. Scheme of the connection of the STATCOM and V-I characteristic.

3.1.3 Dynamic Voltage Restorer (DVR)

Dynamic Voltage Restorer is a series compensator, which works inserting a voltage of magnitude and frequency necessary. Fig. 5 shows the scheme of this FACTS.

DVR consists of a medium voltage switchgear, a coupling transformer, filters, rectifier, inverter, and energy source (e.g. storage capacitor bank) and control and protection system. DVR can inject or absorb real and reactive power independently by an external storage system without reactors and capacitors (Wizmar & Mohd, 2006).

If the storage system is a capacitor bank, during normal operation it will be charging, and when a swell or voltage sag is detected this capacitor will discharge to maintain load voltage supply injecting or absorbing reactive power.

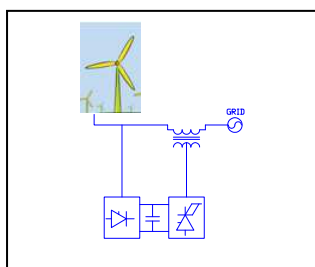

Fig. 5. Scheme of Dynamic Voltage Restorer.

3.1.4 Unified Power Quality Conditioner (UPQC)

Unified Power Quality Conditioner is a combination of a series and a shunt FACTS. Its target is to improve power quality compensating voltage flicker, unbalance, negative-sequence current and harmonics. Fig. 6 shows the scheme of connection of UPQC.

UPQC (Khadkikar et al, 2004) comprises two voltage source inverters connected back to back and sharing a dc link. The shunt inverter helps in compensating load harmonic current

and maintains dc voltage at constant level. The second inverter is connected in series by using a series transformer and helps in maintaining the load voltage sinusoidal and compensate voltage dips and swells.

Control system of UPQC is formed by the positive sequence detector, the series inverter control and the shunt inverter control.

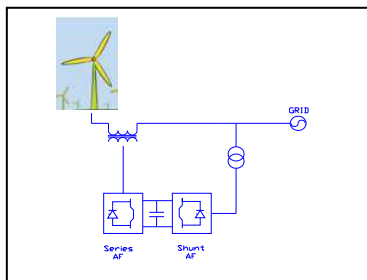

Fig. 6. Scheme of Unified Power-Quality Conditioner.

4. Fault ride through certification procedure for power generating units

Once the requirements for wind power system have been established, another important point is how wind turbine manufacturers and wind park operators can prove the fulfilment of Grid Codes. The Spanish Wind Energy Association (AEE) has developed the document “Procedure for Verification Validation and Certification of the Requirements of the OP 12.3 on the Response of Wind Farms in the Event of Voltage Dips” (PVVC), and the German Fördergesellschaft Windenergie und andere Erneuerbare Energien (FGW) the document “Technical Guidelines for Power Generating Units. Part 8. Certification of the electrical characteristics of power generating units and systems in the medium, high- and highest-voltage grids” that describes the procedures to certify wind power installations according their corresponding Grid Codes.

This section describes the steps to fulfil certificate wind systems by these two procedures.

4.1 PVVC procedure

The PVVC define two possible processes to verify the conformity with the response requirements established in OP 12.3:

- The General Verification Process
- The Particular Verification Process

The General Verification Process consists of verifying that the wind farm does not disconnect and that the requirements stated on the OP 12.3 are met by means of:

- Wind turbine and/or FACTS test
- Wind turbine and/or FACTS validation
- Wind farm simulation

Then three processes must be followed to verify an installation by the General Verification Process and three reports are needed. Next figures show a scheme of these three processes and the three reports obtained. Fig. 7 shows the scheme of the field test process, Fig. 8 the model validation process and Fig. 9 the verification process.



Fig. 7. Field test process.

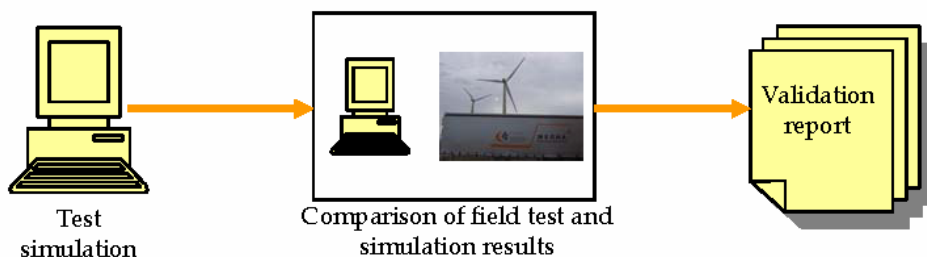

Fig. 8. Validation process.

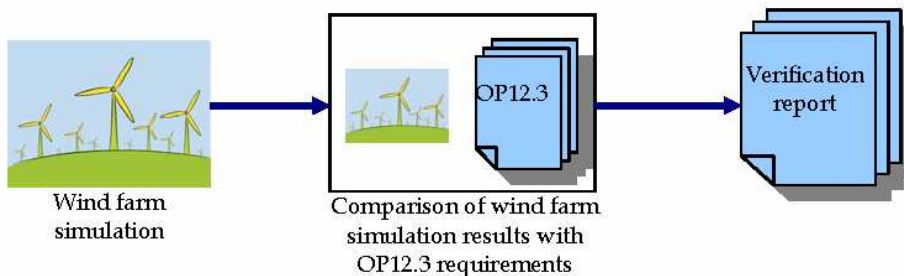

Fig. 9. Verification process.

The particular verification process obtains the direct wind farm verification by testing the dynamic elements of the wind farm. In this case, only the process shown in Fig. 7 must be performed. Model validation and wind farm simulation are not needed. In this case, the conditions of the field test will be harder than those of the general verification process.

The particular verification process is faster and cheaper than the general verification process. Therefore, wind turbine manufacturer and wind farm operators would prefer this process if the wind turbine or the system wind turbine + FACTS can be tested and can ride through the voltage dip test defined in the Particular Verification Process. General Verification Process is necessary in those wind farms whose wind turbines can not ride through the voltage dip defined in the particular process and a compensating system is installed on the wind farm substation to fulfil the OP 12.3 requirements.

4.2 FGW-TG8 procedure

The FGW-TG8 defines two processes depending on the date of commission of the installation that is going to be certificate. If the installation has been commissioned after 01.01.2009 must follow the process for “new generating units”. If the installation has been commissioned after 31.12.2001 and before 01.01.2009 the certification must follow the process for “old systems”.

To certify “new generating units” the applicant must provide:

- Verification of type testing according to FGW-TG3 (FGW, 2009).
- A comprehensive computer based model of the power generating unit, which may be encapsulated as a black box model. This model needs to be suitable to represent the measuring situation of the type tests in accordance with FGW-TG3 (FGW, 2009).
- An open, where necessary simplified, model of the power generating unit. This open model must allow the certifier to follow the logical links between control loops in the relevant system controls. The degree of detail of the open model must be clarified in advance between the certification authority and the manufacturer. In some cases it may be sufficient to present block diagrams. It is necessary to comprehensively describe fault detection for verification of performance in a fault situation.

To certify “old systems” the applicant must provide Verification of type testing according to FGW-TG3. Furthermore the document must contain the specification of the original power generating unit and the specifications on the refitted power generating unit. Model validation does not form part of this procedure.

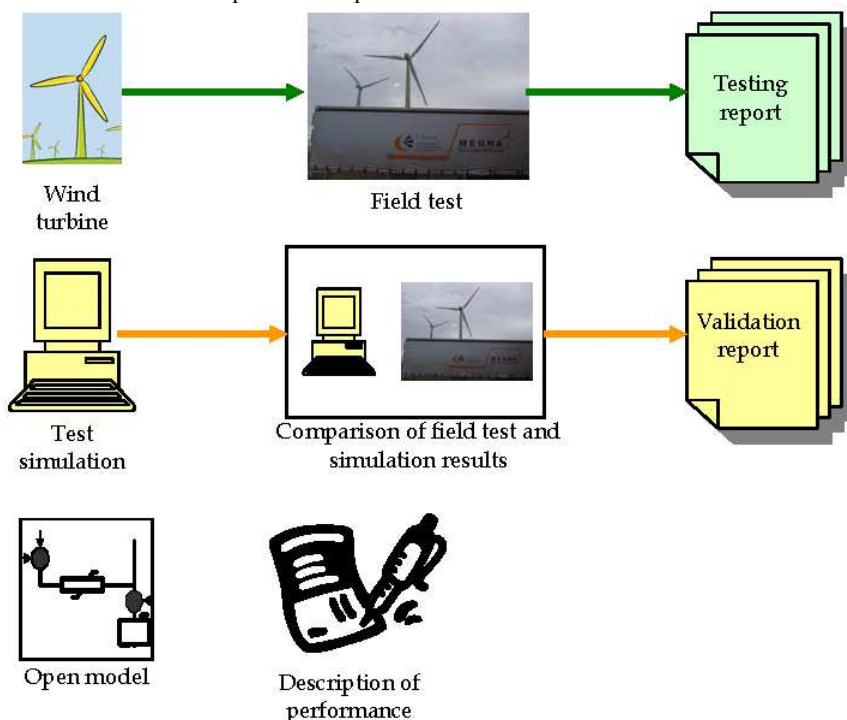

Fig. 10. Process of new unit certification.



Fig. 11. Process of old unit certification.

5. Voltage dip test

In order to test the behaviour of the turbine when a voltage dip occurs and the compliance with Grid Codes, a device able to generate voltage dips is required. This device must create a voltage variation according to the regulations of the different countries in order to check that the tested wind turbine fulfils the established requirements, such as voltage ride-through, short circuit contribution and power factor.

5.1 Voltage dip generator

Voltage dip generators are based on the use of two impedances, as it is shown in Fig. 12 (Niiranen, 2005, 2006; Gamesa eólica, 2006; Gamesa innovation and technology, 2006). The parallel impedance enables the generation of the fault while the series impedance immunizes the grid from the dip and the test can be performed without affecting other systems connected to it.

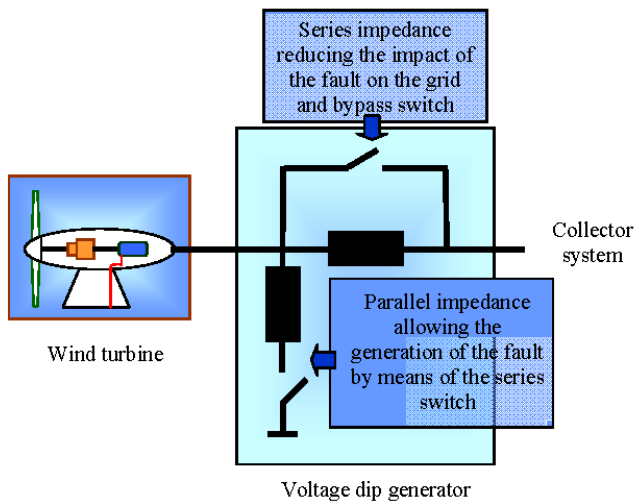

Fig. 12. Dip generator scheme and its position with respect to the windmill and the wind farm.

5.1.1 20 kV 5 MW Voltage dip generator

This section describes the design of a 20 kV, 5 MW voltage dip generator. It is installed in a trailer, so it is able to move to the wind turbine location (García-Gracia et al, 2009).

Fig. 14 shows a scheme of this voltage dip generator. It is based on an inductive divider comprised of a series and a parallel branch, and its main components are a three-phase series impedance (4) at the system input, a parallel tap transformer (7) and a three-phase impedance (11) grounded through a control switch in the secondary of the transformer. This impedance allows the adjustment of the dip depth to the desired value, along with the regulation of the transformer, because the impedance (11) connected to winding 2 is referred to winding 1 by multiplying by the square of the turns ratio. Switches (5) and (9) make possible the generation of a 100% depth voltage dip.



Fig. 13. Picture of the 5 MW test system.

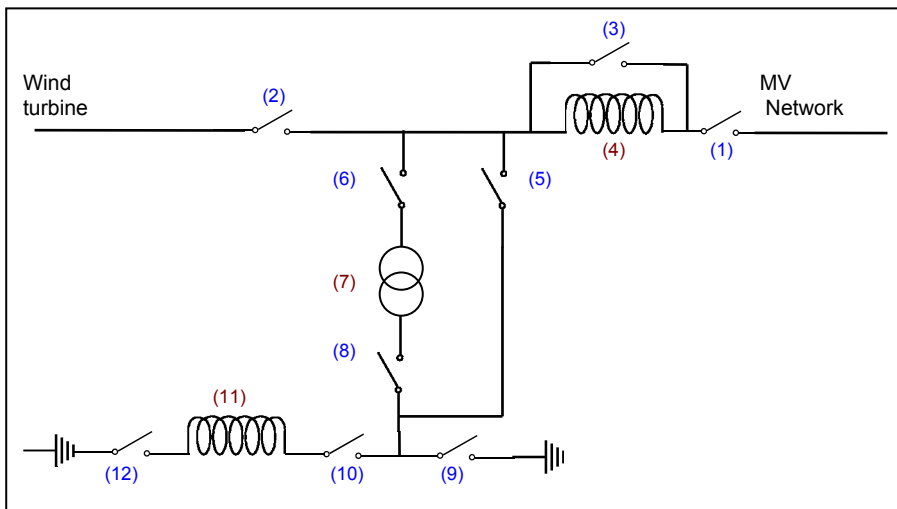

Fig. 14. Scheme of the voltage dip generator.

5.2 Voltage dip test procedure

The system described includes some other control elements in order to perform the voltage dip generation, which takes place as follows. Having the by-pass switch (3) on allows the direct connection between the utility and the generating system (i.e. wind system), eliminating the effect of the insertion of the voltage dip generator.

Once this switch is open, the generator is connected to the grid through the series inductances (4), and the switch (6) connecting the parallel branch can be closed, in order to connect the primary of the transformer (7), which at this point is in no-load operation. Next, the dip generation switch (8) is closed, connecting the secondary of the transformer to the impedances (11) or to the short circuit (9) to achieve a deeper voltage dip. Timing the operation of these switches, the desired dip duration is set. As mentioned before, a 100% voltage dip can be achieved closing switches (5) and (9) after switch (3) has been open. The impedance banks (11) have single-phase switches (10) to have the possibility of performing single-phase, two-phase and three-phase tests.

5.2.1 Wind turbine test according to the Spanish PVVC

The Spanish PVVC distinguish between two different type tests:

- Test for validating the simulation model (General Verification Process)
- Test for direct observance of the OP 12.3 (Particular Verification Process)

For both cases, the wind turbine should be tested for the following operation points:

	Registered Active Power	Power Factor
Partial load	10% - 30% Prated	0.9 inductive - 0.95 capacitive
Full load	> 80% Prated	0.9 inductive - 0.95 capacitive

Table 1. Operation points prior to test.

The depth of the voltage dip must be independent of the wind turbine tested. Therefore, a no-load test must be performed before the connection of the wind turbine. Thus the series inductances (4), the transformer taps (7) and the impedances (11) are adjusted with the switch (2) open.

Table 2 shows the residual voltage, the duration of the voltage dips, and the allowed tolerances of the tests for direct observance of the OP 12.3 (Particular Verification Process).

Dip	Residual dip voltage (Ures)	Voltage tolerance (Utol)	Dip duration (ms)	Time tolerance (Ttol) (ms)
Three phase	$\leq(20\%+Utol)$	+ 3%	$\geq (500-Ttol)$	50
Isolated two phase	$\leq(60\%+Utol)$	+ 10%	$\geq (500-Ttol)$	50

Table 2. Voltage dip properties in the no-load test for the Particular Verification Process.

If the objective of the test is the validation of simulation models (General Verification Process), the minimum voltage registered during the no load test of the faulted phases must be less than 90%.

Before the wind turbine test, it must be checked that the short circuit power in the test point is greater than 5 times the generator rated power. This condition is fulfilled by adjusting (4). Once the voltage dip generator has been adjusted; the test can be performed by closing the switch (2) of the Fig. 14. The four test categories shown in Table 3 must be carried out. Therefore, the power generated by the wind turbine must be measured before the voltage dip, to check the operating point. As the operating point depends on the wind speed, it is possible that the generated power does not match with one of the operating points shown in Table 1. In this case, the laboratory has to wait for the needed weather conditions to perform the test of each operating condition.

Category	Operating point	Dip type
1	Partial load	Three phase
2	Full load	Three phase
3	Partial load	Isolated two phase
4	Full load	Isolated two phase

Table 3. Test categories.

Fig. 15 and Fig. 16 show the measured voltages during a three-phase and a two-phase voltage dip respectively.

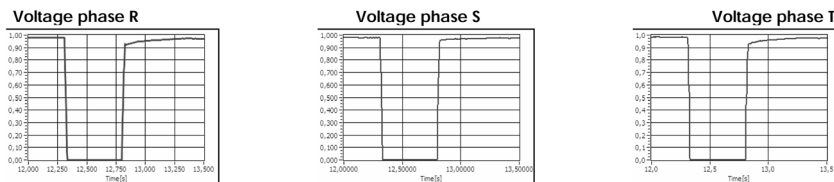

Fig. 15. Three-phase voltage dip: Depth 100%; Duration 510 ms.

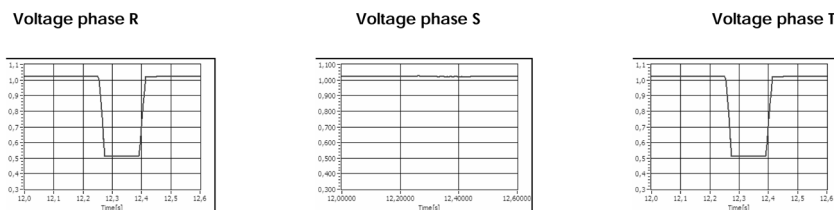

Fig. 16. Two-phase voltage dip: Depth 50%; Duration 150 ms.

To guarantee the continuity of supply, the wind turbine will be undergone to three consecutive tests. If the wind turbine disconnects during this test sequence, four consecutive tests will be performed. If in this new sequence, the wind turbine disconnects, the test will be considered invalid.

To verify wind systems by applying the Particular Verification Process, the power and energy registered must fulfill the requirements shown in Table 4 and Table 5.

Three phase faults	OP 12.3 requirements
ZONE A	
Net consumption $Q < 15\% P_n$ (20 ms)	-0.15 p.u.
ZONE B	
Net consumption $P < 10\% P_n$ (20 ms)	-0.1 p.u.
Net consumption $Q < 5\% P_n$ (20 ms)	-0.05 p.u.
Average I_r/I_{tot}	0.9 p.u.
Extended ZONE C	
Net consumption $I_r < 1.5 I_n$ (20 ms)	-1.5 p.u.

Table 4. Power and energy requirements for three phase voltage dips in the Particular Verification Process.

Two phase faults	OP 12.3 requirements
ZONE B	
Net consumption $E_r < 40\% P_n \cdot 100 \text{ ms}$	-40 ms.p.u.
Net consumption $Q < 40\% P_n (20 \text{ ms})$	-0.4 p.u.
Net consumption $E_a < 45\% P_n \cdot 100 \text{ ms}$	-45 ms p.u.
Net consumption $P < 30\% P_n (20 \text{ ms})$	-0.3 p.u.

Table 5. Power and energy requirements for isolated two phase voltage dips in the Particular Verification Process.

Where the zones A, B and C are defined in Fig. 17.

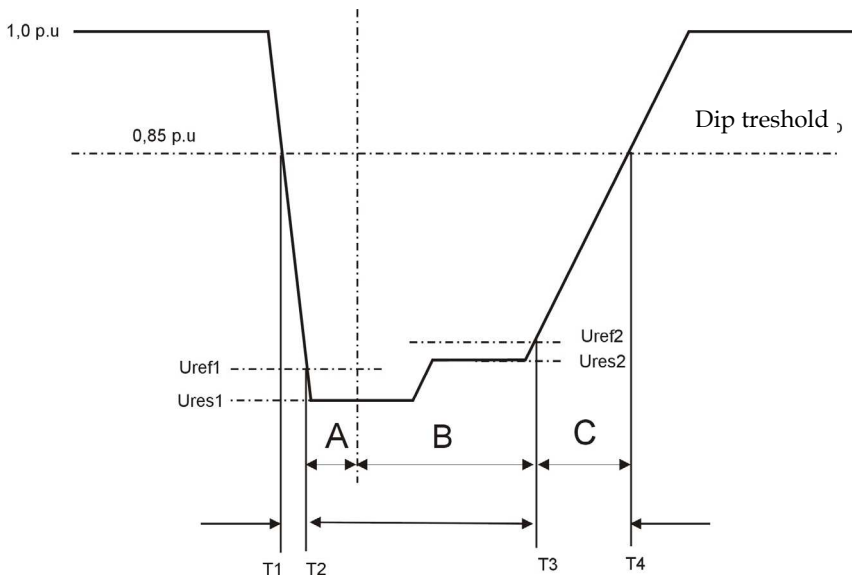

Fig. 17. Classification of the voltage dip in the field test.

5.2.2 Wind turbine test according to the German FGW-TG3

The on-site test should serve the following objectives:

- Validation of the system
- Test the control system and the auxiliary units

For both cases, the wind turbine should be tested for the following operation points:

	Registered Active Power
Partial load	10% - 30% Prated
Full load	> 90% Prated

Table 6. Operation points prior to test.

In this case, the voltage dip generator must have an X/R ratio of at least 3, and the symmetrical fault level on the transformer’s high voltage side must be at least 3.Prated.

The voltage dip generator must be configured in no-load test to obtain the three phase and two phase voltage dips with the different depths shown in Table 7 for directly synchronous generators and Table 8 for the other types, as in the procedure for test according to the Spanish PVVC. Therefore, in the system shown in the Fig. 14, the series inductances (4), the transformer taps (7) and the impedances (11) adjusted with the switch (2) open.

Test number	Ratio of fault voltage to initial voltage (U/U0)	Fault duration (ms)
1	0.05	150
2	0.20-0.25	150
3	0.45-0.55	150
4	0.70-0.80	700

Table 7. Voltage drop test for directly coupled synchronous generators.

Test number	Ratio of fault voltage to initial voltage (U/U0)	Fault duration (ms)
1	0.05	150
2	0.20-0.25	550
3	0.45-0.55	950
4	0.70-0.80	1400

Table 8. Voltage drop test for all the other types of generators.

For three phase voltage dips in accordance with test 3 and 4, minimum proportionality constant (K-factor) is two. This factor is defined in (SDLWindV, 2009) by:

$$\frac{\Delta I_B}{I_N} = K \cdot \frac{\Delta U_r}{U_N} \quad (1)$$

Where I_B is the reactive current, ΔI_B is the reactive current deviation and ΔU_r is the relevant voltage deviation and is calculated as:

$$\Delta U_r = \Delta U + U_t \quad (2)$$

Where ΔU is the voltage deviation and U_t the dead band, that must be kept at a constant maximum of 10% U_N during each test.

6. Model validation

The Spanish PVVC and the German FGW-TG4 (FGW, 2009) give the procedures to validate wind turbine systems by comparing the results obtained by simulation and that obtained from on-site test. PVVC and FGW-TG4 gives the maximum deviation and the specific time intervals for the comparison of the results. The Spanish PVVC establishes a time window of 1 s with 100 ms before the voltage dip, and the German FGW-TG4, 500 ms before the voltage dip and 2 s after the voltage recovery. Fig. 18 shows the different time windows established in each document. It is important to point out that the time window from the PVVC is fixed and does not depend on the voltage dip duration whereas the FGW-TG4 depends on it.

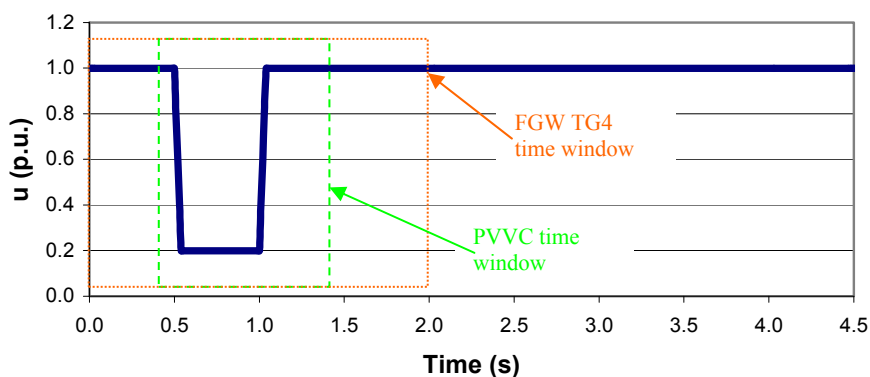

Fig. 18. Time window established in the German FGW-TG4 and the Spanish PVVC.

Respect the maximum deviation, in the Spanish PVVC it is constant and equal to 10% in the time frame, and the German FGW-TG4 establishes these values:

	Deviation F1	Deviation F2	Deviation F3	Total Deviation FG
Active Power $\Delta P/P_n$, Reactive Power $\Delta Q/P_n$	0.07	0.20	0.10	0.15
Reactive current $\Delta I_b/I_r$	0.10	0.20	0.15	0.15

Table 9. Maximum deviation in different stages of voltage dip.

Where F1 is the deviation of the mean of steady state areas, F2 the deviation of the mean of transient areas, F3 the highest deviation in steady state areas and FG the mean of weighted deviations for P, Q and I_b .

Next the validation process followed for a wind turbine generator from in-field testing results according to the Spanish PVVC.

6.1 Voltage dip generator model

In PVVC the system shown in Fig. 19 is proposed. In this system, the voltage measured in the field test is introduced in the simulation and reproduced by a voltage source. Thus, the wind turbine model is subjected to the same voltage than the wind turbine during the field test and only the active and reactive power must be compared to validate the model.

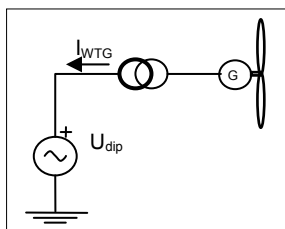

Fig. 19. Voltage dip generator representation in validation simulation.

6.2 Methodology for calculating power

The PVVC explains the following method to calculating power from the test and simulation results.

Using the N samples of the instantaneous values of phase voltage ($u(n)$) and the phase current ($i(n)$) the fundamental harmonic can be obtained using the following expressions:

$$\underline{U}_1 = \frac{\sqrt{2}}{N} \cdot \sum_{n=0}^{N-1} u(n) \cdot e^{-j\left(\frac{2\pi n}{N}\right)} \quad (5)$$

$$\underline{I}_1 = \frac{\sqrt{2}}{N} \cdot \sum_{n=0}^{N-1} i(n) \cdot e^{-j\left(\frac{2\pi n}{N}\right)} \quad (6)$$

To calculate the active and reactive power, only the positive sequence component of the voltage and current are used:

$$\underline{U}^+ = \frac{1}{3} \left(\underline{U}_{1A} + \underline{U}_{1B} \cdot e^{+j\frac{2\pi}{3}} + \underline{U}_{1C} \cdot e^{-j\frac{2\pi}{3}} \right) \quad (7)$$

$$\underline{I}^+ = \frac{1}{3} \left(\underline{I}_{1A} + \underline{I}_{1B} \cdot e^{+j\frac{2\pi}{3}} + \underline{I}_{1C} \cdot e^{-j\frac{2\pi}{3}} \right) \quad (8)$$

The three-phase active and reactive power expressions are obtained from the positive sequence component of the voltage and current as:

$$P = 3 \cdot U^+ \cdot I^+ \cdot \cos(\varphi) \quad (9)$$

$$Q = 3 \cdot U^+ \cdot I^+ \cdot \sin(\varphi) \quad (10)$$

6.3 Model validation

This section describes the model validation process followed for the developed model. Only the three-phase voltage dip for the full load category is shown, the process for the rest of the categories would be the same.

The next figure shows the voltage evolution during the field test and the simulation in phase A. In the simulation, the voltage is introduced by means of a voltage source that reproduces the voltage during the field test. Therefore, there are no significant differences between test and simulation. Voltage in phase B and C are similar to voltage in phase A. In the figure, the blue line represents the voltage obtained during the field test; the red line has been obtained by simulation and the green line the maximum deviation considered in the Spanish PVVC (10%).

Table 10 shows that the model is validated in this category (full load, three phase voltage dip) because the number of the samples with error less than the maximum allowable error for the active and the reactive power are greater than 85%. Fig. 21 shows the comparison of the active power results and Fig. 22 the comparison of the reactive power results. In both figures, the blue line represents the results obtained during the field test; the red line has been obtained by simulation and the green line the maximum deviation considered (10%).

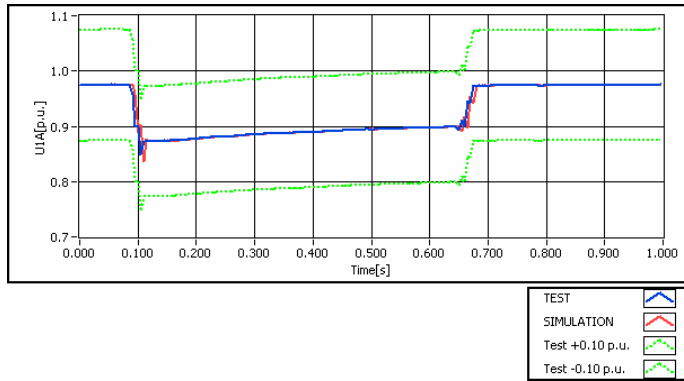

Fig. 20. Voltage evolution during the field test and the simulation in phase A.

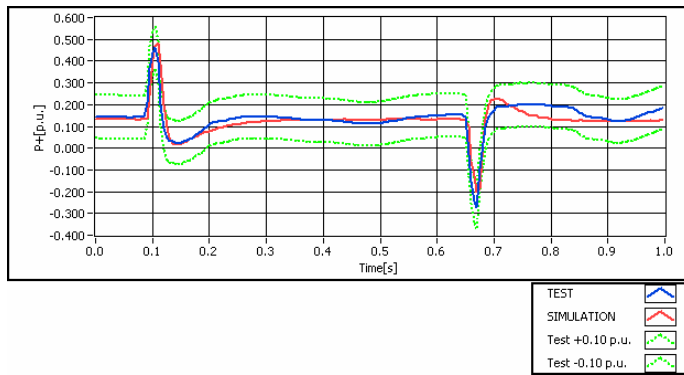

Fig. 21. Comparison of the active power during field test and simulation.

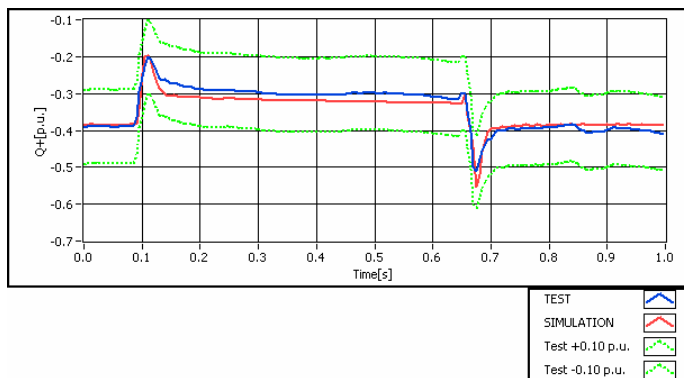

Fig. 22. Comparison of the reactive power during field test and simulation.

¿Is the model validated?	Yes
P samples with error < 0.1 p.u.	97.50
Q samples with error < 0.1 p.u.	100.00

Table 10. Validation results for the example.

7. Wind farm verification

As it has been shown in section 4.1, if the General Verification Process of the PVVC is followed, a simulation study must be performed. The simulation tool used to verify wind installation according to PVVC must permit to model the electrical system components per phase, because balanced and unbalanced perturbances must be analyzed.

The simulated model to verify the installation must take into account the different components of the real system, that is: the wind farm, FACTS and reactive compensating systems, the step-up transformer, the connection line and a equivalent network defined in PVVC. Fig. 23 shows the one line diagram of the network to be simulated.

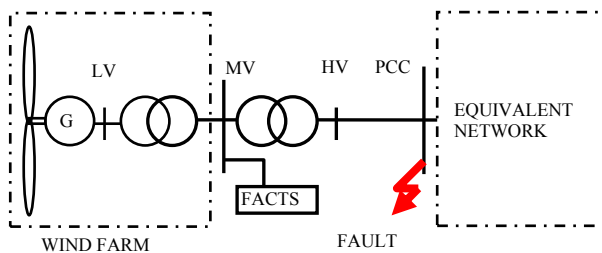

Fig. 23. One line diagram of the wind installation network.

The PVVC establishes the external network model equivalent. This equivalent network reproduces the typical voltage dip profile in the Spanish electrical system, that is a sudden increase in the moment of the clearance and a slower recovery afterwards. The profile for three phase voltage dips is shown in Fig. 24.

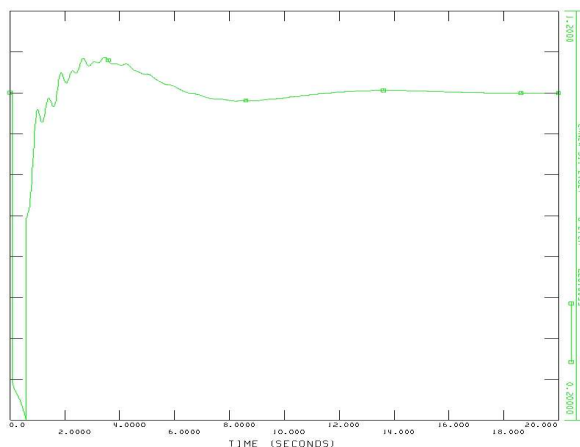

Fig. 24. Voltage profile in the point of connection during the fault and the recovery.

7.1 Wind farm modeling

Wind farm models may be built with different detail levels ranging from one-to-one modeling or by an aggregated model that consists of one or few equivalent wind turbines and an equivalent of the internal network. The aggregated model includes: wind turbine units, compensating capacitors, step-up transformers, etc. Fig. 25 compares the detailed and the aggregated models.

The aggregated model can be used to verify a wind installation according to PVVC when all the wind turbines that form the wind installation are of the same type. If a wind installation is formed by different wind turbines, aggregated model can be done grouping the wind turbines of the same type.

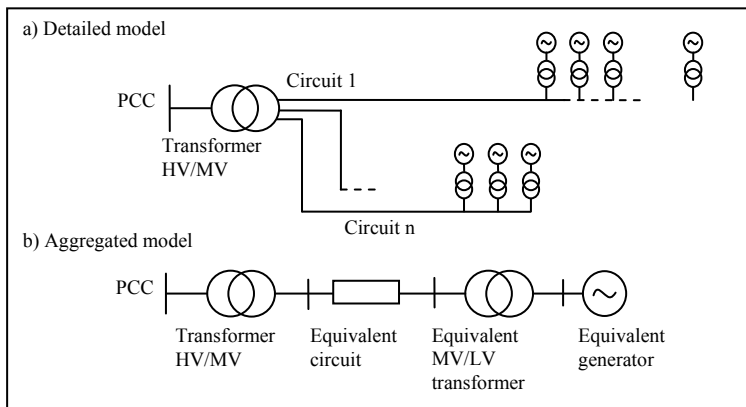

Fig. 25. Wind farm modeling.

Considering identical machines the equivalent generator rating is obtained adding all the machine ratings (García-Gracia et al, 2008):

$$S_{eq} = \sum_{i=1}^n S_i \quad P_{eq} = \sum_{i=1}^n P_i \quad (11)$$

where S_i is the i -th generator apparent power and P_i is the i -th real power.

The inertia H_{eq} and the stiffness coefficient K_{eq} of the equivalent generator are calculated as follows:

$$H_{eq} = \sum_{i=1}^n H_i \quad K_{eq} = \sum_{i=1}^n K_i \quad (12)$$

and the size of the equivalent compensating capacitors is given by:

$$C_{eq} = \sum_{i=1}^n C_i \quad (13)$$

When the aggregated model is used, the difference between the results obtained by the two models must be negligible. Fig. 26 and Fig. 27 show the results obtained in a example wind farm. Fig. 26 shows a comparison between the real power obtained by the simulation of a

detailed and aggregated model. The blue line represents the results of the detailed model, the red line the results of the aggregated model and the green line shows the tolerance (10%). Fig. 27 shows the same comparison for the reactive power. In this case the aggregated model can be used because the differences are negligible during the simulation.

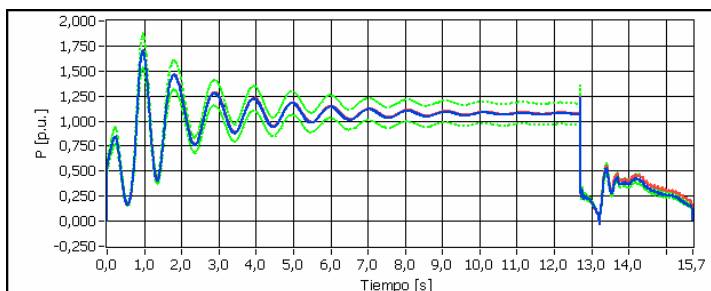

Fig. 26. Real power in the detailed (blue) and the aggregated (red) model.

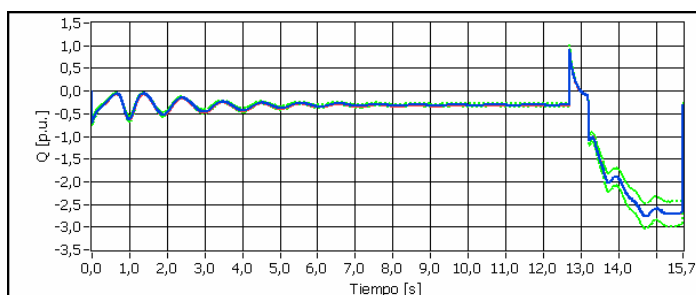

Fig. 27. Reactive power in the detailed (blue) and the aggregated (red) model.

7.2 Modeling wind turbine when there is no available data

Usually, when old installations are going to be verified according to PVVC, there are no available data to model the installation. In these cases, if the rms voltage during the simulation remains above 0.85 p.u., the wind turbines can be represented by a library model that takes into account the generator protections that would disconnect the installation.

If the requirements to use library models are not fulfilled, that is, the voltage falls below 0.85 p.u. during the simulation, validated models of the dynamic parts of the wind installation (wind turbines and FACTS) must be provided by the manufacturers. The model validation must be done according to PVVC (see section 6).

7.2.1 Characteristics of the wind turbine library

Depending on the wind turbine technology, different models must be used.

For squirrel cage induction generator, a fifth order model must be used. If there are manufacturer data available, the behaviour in rated conditions must be checked with a tolerance of 10% for real and reactive power.

If there are not available data, PVVC establishes the data from Table 11, and the rest of the parameters must be calculated to obtain the rated characteristics of the modelled machine.

Stator resistance (p.u.)	0.005 – 0.007
Rotor resistance (p.u.)	0.005 – 0.007
Stator leakage reactance (p.u.)	0.1 – 0.15
Rotor leakage reactance (p.u.)	0.04 – 0.06
Magnetizing reactance (p.u.)	4 – 5

Table 11. Squirrel cage induction generator characteristic parameters.

If there are no manufacturer data for the wind turbine inertia, the value to model the wind turbine is $H = 4$ s.

For the doubly fed induction generator, the simplified model must take into account the rotor dynamics, to determine the overcurrent tripping of the wind turbine during voltage dips.

Finally, the simplified model of the full converter generator consists of a constant current source.

7.3 Evaluation of the wind installation response

Once the system has been modelled, the evaluation simulations must be performed. The test categories and the operation point prior the voltage dip in the verification process are the same of the in-field test, shown in Table 3 and Table 6 (section 5.2), but, in the simulation, the reactive power before the voltage dip must be zero.

In the simulation results, the next requirements must be checked:

1. Continuity of supply. The wind farm must withstand the dips without disconnection. The simulation model must include the protections that determine the disconnection of the wind turbines. As has been shown in section 7.1, there are two possibilities for the wind farm modeling:
 - Detailed model (without aggregation). In this case, the continuity of supply is guaranteed if the real power of the disconnected wind turbines during the simulation does not exceed the 5% of the real power before the dip.
 - Aggregated model. In this case, the continuity of supply is guaranteed if the equivalent generator remains connected during the simulation of the dips.
2. Voltage and current levels at the WTG terminals. Before verification simulations, a no load simulation must be done, in order to check that the depth and the duration of the simulation of the voltage dips fulfil the PVVC requirements (see section 5.2). During the simulation of the four categories shown in Table 3, voltage and current values in each phase must be measured and recorded with a sampling frequency at least of 5 kHz. If a library model is used the voltage must remain above 0.85 p.u. during the simulation
3. Real and reactive power exchanges as described in OP 12.3. The power exchanges must fulfil the requirements shown in Table 12 and Table 13.

The definition of the different zones is shown in Fig. 17.

Three phase faults	OP 12.3 requirements
ZONE A	
Net consumption $Q < 60\% P_n$ (20 ms)	-0.6 p.u.
ZONE B	
Net consumption $P < 10\% P_n$ (20 ms)	-0.1 p.u.
Average I_r/I_{tot}	0.9 p.u.
ZONE C	
Net consumption $E_r < 60\% P_n * 150$ ms	-90 ms*p.u.
Net consumption $I_r < 1.5 I_n$ (20 ms)	-1.5 p.u.

Table 12. Power and energy requirements for three phase voltage dips in the General Verification Process.

Two phase faults	OP 12.3 requirements
ZONE B	
Net consumption $E_r < 40\% P_n * 100$ ms	-40 ms*p.u.
Net consumption $Q < 40\% P_n$ (20 ms)	-0.4 p.u.
Net consumption $E_a < 45\% P_n * 100$ ms	-45 ms*p.u.
Net consumption $P < 30\% P_n$ (20 ms)	-0.3 p.u.

Table 13. Power and energy requirements for isolated two phase voltage dips in the General Verification Process.

8. References

- Amarís, H. (2007). Power Quality Solutions for Voltage dip compensation at Wind Farms, *Power Engineering Society General Meeting*, 2007. IEEE, Issue Date: 24-28 June 2007
- Asociación Empresarial Eólica (AEE). Procedure for verification validation and certification of the requirements of the PO 12.3 on the response of wind farms in the event of voltage dips. November 2007.
http://www.aeolica.es/doc/privado/pvvc_v3_english.pdf
- Bundesministerium der Ordinance on system services by wind energy plants (system services ordinance – SDLWindV), 03 July 2009, published in the Federal Law Gazette 2009, Part I, No. 39
- REE. (2006). Requisitos de respuesta frente a huecos de tensión de las instalaciones de producción de Régimen Especial. Procedimiento de Operación 12.3. Red Eléctrica de España. October 2006.
- Fördergesellschaft Windenergie und andere Erneuerbare Energien (FGW), Technical Guidelines for Power Generating Units. Part 3. Determination of electrical characteristics of power generating units to MV, HV and EHV grids, Revision 20, 01.10.2009
- Fördergesellschaft Windenergie und andere Erneuerbare Energien (FGW), Technical Guidelines for Power Generating Units. Part 4. Requirements for modelling and validation of simulation models of the electrical characteristics of power generating units and systems, Revision 4, 01.10.2009
- Fördergesellschaft Windenergie und andere Erneuerbare Energien (FGW), Technical Guidelines for Power Generating Units. Part 8. Certification of the electrical

- characteristics of power generating units and systems in the medium-, high- and highest-voltage grids, Revision 1, 01.10.2009
- Hingorani, N. G. & Gyugyi, L. (1999). *Understanding FACTS: concepts and technology of flexible AC transmission system*. Wiley-IEEE Press, 1999
- Gamesa Eólica, S.A. Patent WO/2006/108890. Voltage sag generator device. Sag-swell and outage generator for performance test of custom power devices
- Gamesa Innovation and Technology, S.L. Patent WO/2006/106163. Low-Voltage dip generator device.
- García-Gracia, M.; Comech, M.P.; Sallán, J. & Llombart, A. (2008) Modelling wind farms for grid disturbance studies. *Renew Energy* (2008), doi:10.1016/j.renene.2007.12.007.
- García-Gracia, M.; Comech, M.P.; Sallán, J.; Lopez-Andía, D. & Alonso, O. (2009). Voltage dip generator for wind energy systems up to 5 MW, *Applied Energy*, 86 (2009) 565–574, doi:10.1016/j.apenergy.2008.07.006
- Jauch, C.; Sørensen, P.; Norhem, I. & Rasmussen, C. (2007). Simulation of the impact of wind power on the transient fault behaviour of the Nordic power system. *Electric Power Syst Res* 2007;77:135-44.
- Khadkikar, V. ; Aganval, P.; Chandra, A.; Bany A.O. & Nguyen T.D. (2004). A Simple New Control Technique For Unified Power Quality Conditioner (UPQC), *11th International Conference on Harmonics and Quality of Power*
- López, J.; Gubía, E.; Olea, E.; Ruiz, J. & Luis Marroyo, L. (2009). Ride Through of Wind Turbines With Doubly Fed Induction Generator Under Symmetrical Voltage Dips. *IEEE Transactions On Industrial Electronics*, Vol. 56, No. 10, Oct 2009
- Molinas, M.; Suul, J.A. & Undeland, T. (2008). Low Voltage Ride Through of Wind Farms With Cage Generators: STATCOM Versus SVC. *IEEE Transactions On Power Electronics*, Vol. 23, No. 3, May 2008
- Morren, J. & de Haan, S.W.H (2005) .Ridethrough of wind turbines with doubly fed induction generators during a voltage dip. *IEEE Trans. Energy Convers.* vol. 20, no. 2, pp. 435-441, Jun. 2005
- Morren, J. & de Haan, S.W.H. (2007) Short-Circuit current of wind turbines with doubly fed induction generator. *IEEE Trans. On Energy convers*, vol. 22, no. 1, march 2007
- Muyeen, S.M.; Takahashi, R.; Murata, T.; Tamura, J.; Ali, M.H.; Matsumura, Y.; Kuwayama, A. & Matsumoto, T. (2009). Low voltage ride through capability enhancement of wind turbine generator system during network disturbance. *IET Renew. Power Gener.*, 2009, Vol. 3, No. 1, pp. 65–74, ISSN 1752-1416
- Muyeen, S.M. & Rion Takahashi, R. (2010). A Variable Speed Wind Turbine Control Strategy to Meet Wind Farm Grid Code Requirements. *IEEE Transactions On Power Systems*, Vol. 25, No. 1, Feb 2010 331-340
- Niiranen J. Experiences on voltage dip ride through factory testing of synchronous and doubly fed generator drives. *11th European Conference on Power Electronics and Applications*. Dresden 2005
- Rodríguez, J.M.; Fernández, J.L.; Beato, D.; Iturbe, R.; Usaola, J.; Ledesma, P. (2002). Incidence on power system dynamics of high penetration of fixed speed and doubly fed wind energy systems: study of the Spanish case. *IEEE Trans Power Syst* 2002;17(4):1089-95
- Wizmar Wahab, S.; and Mohd Yusof. A. (Elektrika Voltage Sag and Mitigation Using Dynamic Voltage Restorer (DVR) System. VOL. 8, NO. 2, 2006, 32-37

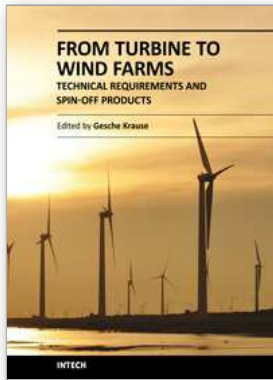

From Turbine to Wind Farms - Technical Requirements and Spin-Off Products

Edited by Dr. Gesche Krause

ISBN 978-953-307-237-1

Hard cover, 218 pages

Publisher InTech

Published online 04, April, 2011

Published in print edition April, 2011

This book is a timely compilation of the different aspects of wind energy power systems. It combines several scientific disciplines to cover the multi-dimensional aspects of this yet young emerging research field. It brings together findings from natural and social science and especially from the extensive field of numerical modelling.

How to reference

In order to correctly reference this scholarly work, feel free to copy and paste the following:

María Paz Comech, Miguel García-Gracia, Susana Martín Arroyo and Miguel Ángel Martínez Guillén (2011). Wind Farms and Grid Codes, From Turbine to Wind Farms - Technical Requirements and Spin-Off Products, Dr. Gesche Krause (Ed.), ISBN: 978-953-307-237-1, InTech, Available from:

<http://www.intechopen.com/books/from-turbine-to-wind-farms-technical-requirements-and-spin-off-products/wind-farms-and-grid-codes>

INTECH

open science | open minds

InTech Europe

University Campus STeP Ri
Slavka Krautzeka 83/A
51000 Rijeka, Croatia
Phone: +385 (51) 770 447
Fax: +385 (51) 686 166
www.intechopen.com

InTech China

Unit 405, Office Block, Hotel Equatorial Shanghai
No.65, Yan An Road (West), Shanghai, 200040, China
中国上海市延安西路65号上海国际贵都大饭店办公楼405单元
Phone: +86-21-62489820
Fax: +86-21-62489821

© 2011 The Author(s). Licensee IntechOpen. This chapter is distributed under the terms of the [Creative Commons Attribution-NonCommercial-ShareAlike-3.0 License](#), which permits use, distribution and reproduction for non-commercial purposes, provided the original is properly cited and derivative works building on this content are distributed under the same license.