

# Fouling of Heat Transfer Surfaces

Mostafa M. Awad

*Mansoura University, Faculty of Engineering, Mech. Power Eng. Dept.,  
Egypt*

## 1. Introduction

Fouling is generally defined as *the accumulation and formation of unwanted materials on the surfaces of processing equipment*, which can seriously deteriorate the capacity of the surface to transfer heat under the temperature difference conditions for which it was designed. Fouling of heat transfer surfaces is one of the most important problems in heat transfer equipment. Fouling is an extremely complex phenomenon. Fundamentally, fouling may be characterized as a combined, unsteady state, momentum, mass and heat transfer problem with chemical, solubility, corrosion and biological processes may also taking place. It has been described as *the major unresolved problem in heat transfer*<sup>1</sup>.

According to many [1-3], fouling can occur on any fluid-solid surface and have other adverse effects besides reduction of heat transfer. It has been recognized as a nearly universal problem in design and operation, and it affects the operation of equipment in two ways: Firstly, the fouling layer has a low thermal conductivity. This increases the resistance to heat transfer and reduces the effectiveness of heat exchangers. Secondly, as deposition occurs, the cross sectional area is reduced, which causes an increase in pressure drop across the apparatus.

In industry, fouling of heat transfer surfaces has always been a recognized phenomenon, although poorly understood. Fouling of heat transfer surfaces occurs in most chemical and process industries, including oil refineries, pulp and paper manufacturing, polymer and fiber production, desalination, food processing, dairy industries, power generation and energy recovery. By many, fouling is considered the single most unknown factor in the design of heat exchangers. This situation exists despite the wealth of operating experience accumulated over the years and accumulation of the fouling literature. This lack of understanding almost reflects the complex nature of the phenomena by which fouling occurs in industrial equipment. The wide range of the process streams and operating conditions present in industry tends to make most fouling situations unique, thus rendering a general analysis of the problem difficult.

In general, the ability to transfer heat efficiently remains a central feature of many industrial processes. As a consequence much attention has been paid to improving the understanding of heat transfer mechanisms and the development of suitable correlations and techniques that may be applied to the design of heat exchangers. On the other hand relatively little consideration has been given to the problem of surface fouling in heat exchangers. The

---

<sup>1</sup> The unresolved problems in heat transfer are: flow induced tube vibration, fouling, mixture boiling, flow distribution in two-phase flow and detailed turbulence flow modelling.

principal purpose of this chapter is to provide some insight into the problem of fouling from a scientific and technological standpoint. A better understanding of the problem and of the mechanisms that lead to the accumulation of deposits on surfaces will provide opportunities to reduce or even eliminate the problem in certain situations.

Fouling can occur as a result of the fluids being handled and their constituents in combination with the operating conditions such as temperature and velocity. Almost any solid or semi solid material can become a heat exchanger foulant, but some materials that are commonly encountered in industrial operations as foulants include:

Inorganic materials

- Airborne dusts and grit
- Waterborne mud and silts
- Calcium and magnesium salts
- Iron oxide

Organic materials

- Biological substances, e.g. bacteria, fungi and algae
- Oils, waxes and greases
- Heavy organic deposits, e.g. polymers, tars
- Carbon

Energy conservation is often a factor in the economics of a particular process. At the same time in relation to the remainder of the process equipment, the proportion of capital that is required to install the exchangers is relatively low. It is probably for this reason that heat exchanger fouling has been neglected as most fouling problems are unique to a particular process and heat exchanger design. The problem of heat exchanger fouling therefore represents a challenge to designers, technologists and scientists, not only in terms of heat transfer technology but also in the wider aspects of economics and environmental acceptability and the human dimension.

## 2. Types of fouling

Many types of fouling can occur on the heat transfer surfaces. The generally favored scheme for the classification of the heat transfer fouling is based on the different physical and chemical processes involved. Nevertheless, it is convenient to classify the fouling main types as:

**1. Particulate fouling:** It is the deposition of suspended particles in the process streams onto the heat transfer surfaces. If the settling occurs due to gravity as well as other deposition mechanisms, the resulting particulate fouling is called "sedimentation" fouling. Hence, particulate fouling may be defined as the accumulation of particles from heat exchanger working fluids (liquids and/or gaseous suspensions) on the heat transfer surface. Most often, this type of fouling involves deposition of corrosion products dispersed in fluids, clay and mineral particles in river water, suspended solids in cooling water, soot particles of incomplete combustion, magnetic particles in economizers, deposition of salts in desalination systems, deposition of dust particles in air coolers, particulates partially present in fire-side (gas-side) fouling of boilers, and so on. The particulate fouling is influenced by the following factors: concentration of suspended particles, fluid flow velocity, temperature conditions on the fouled surface (heated or nonheated), and heat flux at the heat transfer surface.

**2. Crystallization or precipitation fouling:** It is the crystallization of dissolved salts from saturated solutions, due to solubility changes with temperature, and subsequent precipitation onto the heat transfer surface. It generally occurs with aqueous solutions and

other liquids of soluble salts which are either being heated or cooled. The deposition of inverse solubility salts on heated surfaces, usually called "scaling" and its deposited layer is hard and tenacious. The deposition of normal solubility salts on cooled surfaces, usually has porous and mushy deposited layers and it is called "sludge", "softscale", or "powdery deposit". Precipitation/crystallization fouling is common when untreated water, seawater, geothermal water, brine, aqueous solutions of caustic soda, and other salts are used in heat exchangers. The most important phenomena involved with this type of fouling include crystal growth during precipitation require formation of a primary nucleus. The mechanism controlling that process is nucleation, as a rule heterogeneous in the presence of impurities and on the heat transfer surface.

**3. Chemical reaction fouling:** The deposition in this case is the result of one or more chemical reactions between reactants contained in the flowing fluid in which the surface material *itself* is not a reactant or participant. However, the heat transfer surface may act as a catalyst as in cracking, coking, polymerization, and autoxidation. Thermal instabilities of chemical species, such as asphaltenes and proteins, can also induce fouling precursors. This fouling occurs over a wide temperature range from ambient to over 1000°C but is more pronounced at higher temperatures. The mechanism of this type of fouling is a consequence of an unwanted chemical reaction that takes place during the heat transfer process. Chemical reaction fouling is found in many applications of process industry, such as petrochemical industries, oil refining, vapor-phase pyrolysis, cooling of gas and oils, polymerization of process monomers, and so on. Furthermore, fouling of heat transfer surface by biological fluids may involve complex heterogeneous chemical reactions and physicochemical processes. The deposits from chemical reaction fouling may promote corrosion at the surface if the formation of the protective oxide layer is inhibited.

**4. Corrosion fouling:** It involves a chemical or electrochemical reaction between the heat transfer surface *itself* and the fluid stream to produce corrosion products which, in turn, change the surface thermal characteristics and foul it. Corrosion may cause fouling in two ways. First, corrosion products can accumulate and adhere to the surface providing resistance to heat transfer. Second, corrosion products may be transported as particulate materials from the corrosion site and be deposited as particulate fouling on the heat transfer surface in another site of the system. For example, fouling on the water side of boilers may be caused by corrosion products that originate in the condenser or feedtrain. Corrosion fouling is prevalent in many applications where chemical reaction fouling takes place and the protective oxide layer is not formed on the surface. It is of significant importance in the design of the boiler and condenser of a fossil fuel-fired power plant.

**5. Biological fouling:** It is the attachment and growth of macroorganisms and /or microorganisms and their products on the heat transfer surface. It is usually called "Biofouling", and it is generally a problem in water streams. In general, biological fouling can be divided into two main subtypes of fouling: microbial and macrobial. Microbial fouling is accumulation of microorganisms such as algae, fungi, yeasts, bacteria, and molds, and macrobial fouling represents accumulation of macroorganisms such as clams, barnacles, mussels, and vegetation as found in seawater or estuarine cooling water. Microbial fouling precedes macrobial deposition as a rule and may be considered of primary interest. Biological fouling is generally in the form of a biofilm or a slime layer on the surface that is uneven, filamentous, and deformable but difficult to remove. Although biological fouling

could occur in suitable liquid streams, it is generally associated with open recirculation or once-through systems with cooling water. Biological fouling may promote corrosion fouling under the slime layer.

**6. Solidification or freezing fouling:** It is the freezing of a pure liquid or a higher melting point components of a multicomponent solution onto a subcooled surfaces. Separation of waxes from hot streams when it come to contact with cooled surfaces, formation of ice on a heat transfer surface during chilled water production or cooling of moist air, deposits formed in phenol coolers, and deposits formed during cooling of mixtures of substances such as paraffin are some examples of solidification fouling. This fouling mechanism occurs at low temperatures, usually ambient and below depending on local pressure conditions. The main factors affecting solidification fouling are mass flow rate of the working fluid, temperature and crystallization conditions, surface conditions, and concentration of the solid precursor in the fluid.

It should be noted that, in many applications, where more than one fouling mechanism is present, the fouling problem becomes very complex with their synergistic effects. It is obvious that one cannot talk about a single, unified theory to model the fouling process wherein not only the foregoing six types of fouling mechanisms are identified, but in many processes more than one fouling mechanism exists with synergistic effects.

### 3. Fouling processes

The overall fouling process is usually considered to be the net result of two simultaneous sub-processes; a deposition process and a removal (reentrainment) process. A schematic representation of fouling process is given in Fig. (1). All sub-processes can be summarized as:

- Formation of foulant materials in the bulk of the fluid.
- Transport of foulant materials to the deposit-fluid interface.
- Attachment/ formation reaction at the deposit-fluid interface.
- Removal of the fouling deposit ( spalling or sloughing of the deposit layer).
- Transport from the deposit-fluid interface to the bulk of the fluid.

A schematic diagram for the fouling processes is shown in Fig. (2). It must be noted that, some of these sub-processes may not be applicable in certain fouling situations such as corrosion fouling.

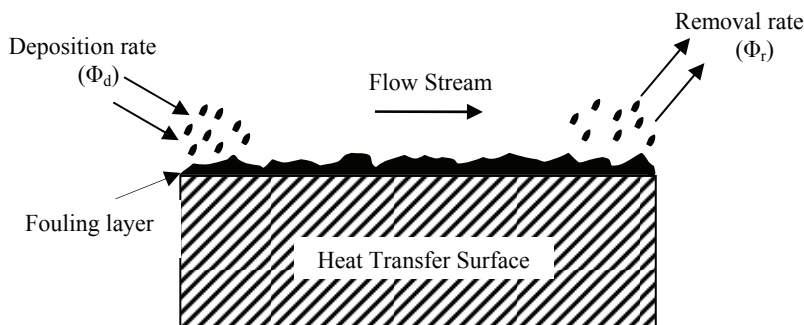

Fig. 1. Fouling processes

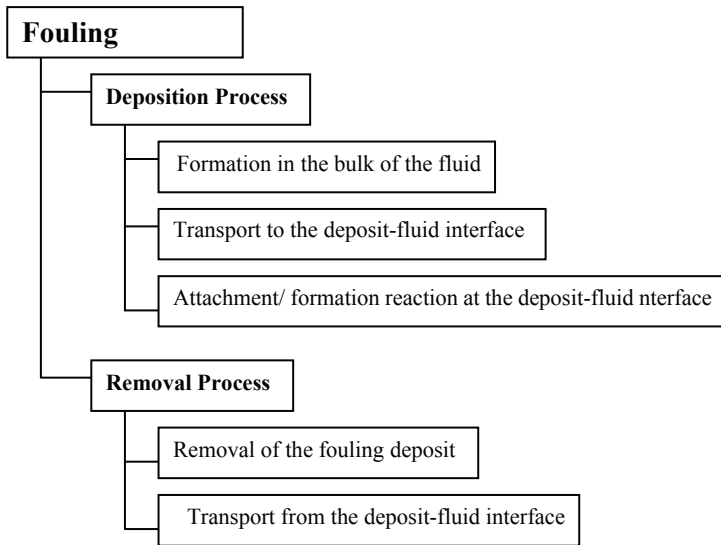

Fig. 2. Schematic diagram for the fouling processes

In another way, three basic stages may be visualized in relation to deposition on surfaces from a moving fluid. They are:

1. The diffusional transport of the foulant or its precursors across the boundary layers adjacent to the solid surface within the flowing fluid.
2. The adhesion of the deposit to the surface and to itself.
3. The transport of material away from the surface.

The sum of these basic components represents the growth of the deposit on the surface.

In mathematical terms the rate of deposit growth (fouling resistance or fouling factor,  $R_f$ ) may be regarded as the difference between the deposition and removal rates as:

$$R_f = \Phi_d - \Phi_r \quad (1)$$

where  $\Phi_d$  and  $\Phi_r$  are the rates of deposition and removal respectively.

The fouling factor,  $R_f$ , as well as the deposition rate,  $\Phi_d$ , and the removal rate,  $\Phi_r$ , can be expressed in the units of thermal resistance as  $m^2 \cdot K/W$  or in the units of the rate of thickness change as  $m/s$  or units of mass change as  $kg/m^2 \cdot s$ .

#### 4. Deposition and removal mechanisms

From the empirical evidence involving various fouling mechanisms discussed in Section 2, it is clear that virtually all these mechanisms are characterized by a similar sequence of events. The successive events occurring in most cases are illustrated in Fig. (2). These events govern the overall fouling process and determine its ultimate impact on heat exchanger performance. In some cases, certain events dominate the fouling process, and they have a direct effect on the type of fouling to be sustained. The main five events can be summarized briefly as following:

1-Formation of foulant materials in the bulk of the fluid or initiation of the fouling, the first event in the fouling process, is preceded by a delay period or induction period,  $t_d$  as shown in Fig. (3), the basic mechanism involved during this period is heterogeneous nucleation, and  $t_d$  is shorter with a higher nucleation rate. The factors affecting  $t_d$  are temperature, fluid velocity, composition of the fouling stream, and nature and condition of the heat exchanger surface. Low-energy surfaces (unwettable) exhibit longer induction periods than those of high-energy surfaces (wetable). In crystallization fouling,  $t_d$  tends to decrease with increasing degree of supersaturation. In chemical reaction fouling,  $t_d$  appears to decrease with increasing surface temperature. In all fouling mechanisms,  $t_d$  decreases as the surface roughness increases due to available suitable sites for nucleation, adsorption, and adhesion.

2-Transport of species means transfer of the fouling species itself from the bulk of the fluid to the heat transfer surface. Transport of species is the best understood of all sequential events. Transport of species takes place through the action of one or more of the following mechanisms:

- *Diffusion*: involves mass transfer of the fouling constituents from the flowing fluid toward the heat transfer surface due to the concentration difference between the bulk of the fluid and the fluid adjacent to the surface.
- *Electrophoresis*: under the action of electric forces, fouling particles carrying an electric charge may move toward or away from a charged surface depending on the polarity of the surface and the particles. Deposition due to electrophoresis increases with decreasing electrical conductivity of the fluid, increasing fluid temperature, and increasing fluid velocity. It also depends on the pH of the solution. Surface forces such as London-van der Waals and electric double layer interaction forces are usually responsible for electrophoretic effects.
- *Thermophoresis*: a phenomenon whereby a "thermal force" moves fine particles in the direction of negative temperature gradient, from a hot zone to a cold zone. Thus, a high-temperature gradient near a hot wall will prevent particles from depositing, but the same absolute value of the gradient near a cold wall will promote particle deposition. The thermophoretic effect is larger for gases than for liquids.
- *Diffusiophoresis*: involves condensation of gaseous streams onto a surface.
- *Sedimentation*: involves the deposition of particulate matters such as rust particles, clay, and dust on the surface due to the action of gravity. For sedimentation to occur, the downward gravitational force must be greater than the upward drag force. Sedimentation is important for large particles and low fluid velocities. It is frequently observed in cooling tower waters and other industrial processes where rust and dust particles may act as catalysts and/or enter complex reactions.
- *Inertial impaction*: a phenomenon whereby "large" particles can have sufficient inertia that they are unable to follow fluid streamlines and as a result, deposit on the surface.
- *Turbulent downsweeps*: since the viscous sublayer in a turbulent boundary layer is not truly steady, the fluid is being transported toward the surface by turbulent downsweeps. These may be thought of as suction areas of measurable strength distributed randomly all over the surface.

3-Attachment of the fouling species to the surface involves both physical and chemical processes, and it is not well understood. Three interrelated factors play a crucial role in the attachment process: surface conditions, surface forces, and sticking probability. It is the combined and simultaneous action of these factors that largely accounts for the event of attachment.

- *Surface properties:* The properties of surface conditions important for attachment are the surface free energy, wettability (contact angle, spreadability), and heat of immersion. Wettability and heat of immersion increase as the difference between the surface free energy of the wall and the adjacent fluid layer increases. Unwettable or low-energy surfaces have longer induction periods than wettable or high-energy surfaces, and suffer less from deposition (such as polymer and ceramic coatings). Surface roughness increases the effective contact area of a surface and provides suitable sites for nucleation and promotes initiation of fouling. Hence, roughness increases the wettability of wettable surfaces and decreases the unwettability of the unwettable ones.
- *Surface forces:* The most important one is the London-van der Waals force, which describes the intermolecular attraction between nonpolar molecules and is always attractive. The electric double layer interaction force can be attractive or repulsive. Viscous hydrodynamic force influences the attachment of a particle moving to the wall, which increases as it moves normal to the plain surface.
- *Sticking probability:* represents the fraction of particles that reach the wall and stay there before any reentrainment occurs. It is a useful statistical concept devised to analyze and explain the complicated event of attachment.

4-Removal of the fouling deposits from the surface may or may not occur simultaneously with deposition. Removal occurs due to the single or simultaneous action of the following mechanisms; shear forces, turbulent bursts, re-solution, and erosion.

- *Shear forces* result from the action of the shear stress exerted by the flowing fluid on the depositing layer. As the fouling deposit builds up, the cross-sectional area for flow decreases, thus causing an increase in the average velocity of the fluid for a constant mass flow rate and increasing the shear stress. Fresh deposits will form only if the deposit bond resistance is greater than the prevailing shear forces at the solid-fluid interface.
- *Randomly distributed* (about less than 0.5% at any instant of time) periodic turbulent bursts act as miniature tornadoes lifting deposited material from the surface. By continuity, these fluid bursts are compensated for by gentler fluid back sweeps, which promote deposition.
- *Re-solution:* The removal of the deposits by re-solution is related directly to the solubility of the material deposited. Since the fouling deposit is presumably insoluble at the time of its formation, dissolution will occur only if there is a change in the properties of the deposit, or in the flowing fluid, or in both, due to local changes in temperature, velocity, alkalinity, and other operational variables. For example, sufficiently high or low temperatures could kill a biological deposit, thus weakening its attachment to a surface and causing sloughing or re-solution. The removal of corrosion deposits in power-generating systems is done by re-solution at low alkalinity. Re-solution is associated with the removal of material in ionic or molecular form.
- *Erosion* is closely identified with the overall removal process. It is highly dependent on the shear strength of the foulant and on the steepness and length of the sloping heat exchanger surfaces, if any. Erosion is associated with the removal of material in particulate form. The removal mechanism becomes largely ineffective if the fouling layer is composed of well-crystallized pure material (strong formations); but it is very effective if it is composed of a large variety of salts each having different crystal properties.

5- Transport from the deposit-fluid interface to the bulk of the fluid, once the deposits are sloughed, it may/may not be transported from the deposit-fluid interface to the bulk of the fluid. This depends on the mass and volume of the sloughed piece and on the hydrodynamic forces of the flowing fluid. If the sloughed piece is large enough, it may be moved on the surface and deposited on another site on the system such as some corrosion products. All deposits which are removed due to erosion effect will be transported to the bulk of the fluid. The removal process is not complete without this action. The important parameter affecting the deposit sloughing is the aging of deposits in which it may strengthen or weaken the fouling deposits.

## 5. Fouling curves

The overall process of fouling is indicated by the fouling factor,  $R_f$  (fouling resistance) which is measured either by a test section or evaluated from the decreased capacity of an operating heat exchanger. The representation of various modes of fouling with reference to time is known as a fouling curve (fouling factor-time curve). Typical fouling curves are shown in Fig. (3).

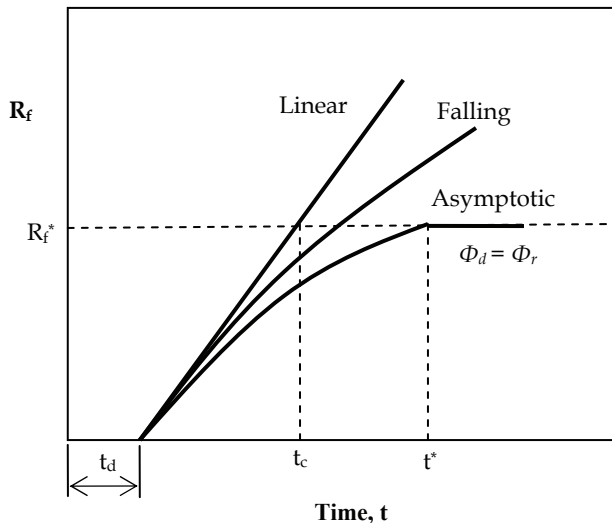

Fig. 3. Fouling Curves

The delay time,  $t_d$  indicates that an initial period of time can elapse where no fouling occurs. The value of  $t_d$  is not predictable, but for a given surface and system, it appears to be somewhat random in nature or having a normal distribution about some mean value or at least dependent upon some frequency factors. After cleaning the fouled surfaces and reusing them, the delay time,  $t_d$  is usually shorter than that of the new surfaces when they are used for the first time. It must be noted that, the nature of the fouling factor-time curve is not a function of  $t_d$ . The most important fouling curves are:

- **Linear fouling curve** is indicative of either a constant deposition rate,  $\Phi_d$  with removal rate,  $\Phi_r$  being negligible (i.e.  $\Phi_d = \text{constant}$ ,  $\Phi_r \approx 0$ ) or the difference between  $\Phi_d$  and  $\Phi_r$



is constant (i.e.  $\Phi_d - \Phi_r = \text{constant}$ ). In this mode, the mass of deposits increases gradually with time and it has a straight line relationship of the form ( $R_f = at$ ) where “a” is the slope of the line.

- **Falling rate fouling curve** results from either decreasing deposition rate,  $\Phi_d$  with removal rate,  $\Phi_r$  being constant or decreasing deposition rate,  $\Phi_d$  and increasing removal rate,  $\Phi_r$ . In this mode, the mass of deposit increases with time but not linearly and does not reach the steady state of asymptotic value.
- **Asymptotic fouling curve** is indicative of a constant deposition rate,  $\Phi_d$  and the removal rate,  $\Phi_r$  being directly proportional to the deposit thickness until  $\Phi_d = \Phi_r$  at the asymptote. In this mode, the rate of fouling gradually falls with time, so that eventually a steady state is reached when there is no net increase of deposition on the surface and there is a possibility of continued operation of the equipments without additional fouling. In practical industrial situations, the asymptote may be reached and the asymptotic fouling factor,  $R_f^*$  is obtained in a matter of minutes or it may take weeks or months to occur depending on the operating conditions. The general equation describing this behavior is given in equation (4). This mode is the most important one in which it is widely existed in the industrial applications. The pure particulate fouling is one of this type.

For all fouling modes, the amount of material deposited per unit area,  $m_f$  is related to the fouling resistance ( $R_f$ ), the density of the foulant ( $\rho_f$ ), the thermal conductivity ( $\lambda_f$ ) and the thickness of the deposit ( $x_f$ ) by the following equation:

$$m_f = \rho_f x_f = \rho_f \lambda_f R_f \tag{2}$$

where

$$R_f = \frac{x_f}{\lambda_f} \tag{3}$$

(values of thermal conductivities for some foulants are given in table 1).

Foulant	Thermal conductivity (W/mK)
Alumina	0.42
Biofilm (effectively water)	0.6
Carbon	1.6
Calcium sulphate	0.74
Calcium carbonate	2.19
Magnesium carbonate	0.43
Titanium oxide	8.0
Wax	0.24

Table 1. Thermal conductivities of some foulants [2]

It should be noted that, the curves represented in Fig. (3) are ideal ones while in the industrial situations, ideality may not be achieved. A closer representation of asymptotic fouling practical curve might be as shown in Fig. (4). The “saw tooth” effect is the result of partial removal of some deposit due to “spalling” or “sloughing” to be followed for a short

time by a rapid build up of deposit. The average curve (represented by the dashed line) can be seen to represent the ideal asymptotic curve on Fig. (3). Similar effects of partial removal and deposition may be experienced with the other types of foulin curves.

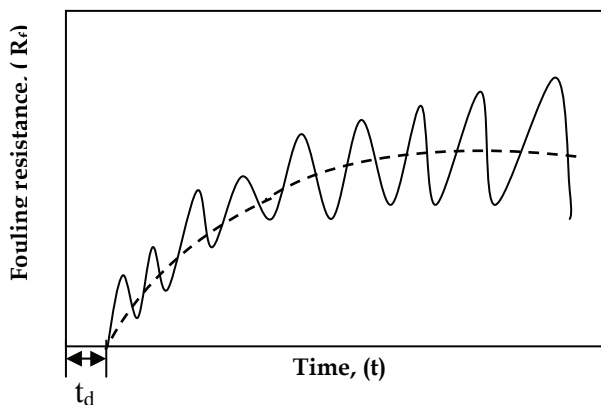

Fig. 4. Practical fouling curve

## 6. Cost of fouling

Fouling affects both capital and operating costs of heat exchangers. The extra surface area required due to fouling in the design of heat exchangers, can be quite substantial. Attempts have been made to make estimates of the overall costs of fouling in terms of particular processes or in particular countries. Reliable knowledge of fouling economics is important when evaluating the cost efficiency of various mitigation strategies. The total fouling-related costs can be broken down into four main areas:

4. Higher capital expenditures for oversized plants which includes excess surface area (10-50%), costs for extra space, increased transport and installation costs.
5. Energy losses due to the decrease in thermal efficiency and increase in the pressure drop.
6. Production losses during planned and unplanned plant shutdowns for fouling cleaning.
7. Maintenance including cleaning of heat transfer equipment and use of antifoulants.

The loss of heat transfer efficiency usually means that somewhere else in the system, additional energy is required to make up for the short fall. The increased pressure drop through a heat exchanger represents an increase in the pumping energy required to maintain the same flow rate. The fouling resistance used in any design brings about 50% increase in the surface area over that required if there is no fouling. The need for additional maintenance as a result of fouling may be manifested in different ways. In general, any extensive fouling means that the heat exchanger will have to be cleaned on a regular basis to restore the loss of its heat transfer capacity. According to Pritchard [4], the total heat exchanger fouling costs for highly industrialized countries are about 0.25% of the countries' Gross National Product (GNP). Table (2) shows the annual costs of fouling in some different countries based on 1992 estimation.

Country	Fouling Costs (million \$)	Fouling Cost /GNP %
US	14175	0.25
UK	2500	0.25
Germany	4875	0.25
France	2400	0.25
Japan	10000	0.25
Australia	463	0.15
New Zealand	64.5	0.15

Table 2. Annual costs of fouling in some countries (1992 estimation) [5].

From this table, it is clear that fouling costs are substantial and any reduction in these costs would be a welcome contribution to profitability and competitiveness. The frequency of cleaning will of course depend upon the severity of the fouling problem and may range between one week and one year or longer. Frequent cleaning involving repeated dismantling and reassembly will inevitably result in damage to the heat exchanger at a lesser or greater degree, which could shorten the useful life of the equipment. Fouling can be very costly in refinery and petrochemical plants since it increases fuel usage, results in interrupted operation and production losses, and increases maintenance costs.

### Increased Capital Investment

In order to make allowance for potential fouling the area for a given heat transfer surface is larger than for clean conditions. To accommodate the fouling-related drop in heat transfer capacity, the tubular exchangers are generally designed with 20-50% excess surface, where the compact heat exchangers are designed with 15-25% excess surface. In addition to the actual size of the heat exchanger other increased capital costs are likely. For instance where it is anticipated that a particular heat exchanger is likely to suffer severe or difficult fouling, provision for off-line cleaning will be required. The location of the heat exchanger for easy access for cleaning may require additional pipe work and larger pumps compared with a similar heat exchanger operating with little or no fouling placed at a more convenient location. Furthermore if the problem of fouling is thought to be excessive it might be necessary to install a standby exchanger, with all the associated pipe work foundations and supports, so that one heat exchanger can be operated while the other is being cleaned and serviced.

Under these circumstances the additional capital cost is likely to more than double and with allowances for heavy deposits the final cost could be 4 - 8 times the cost of the corresponding exchanger running in a clean condition. Additional capital costs may be considered for on-line cleaning such as the Taprogge system (see sec. 12) or other systems. It has to be said however, that on-line cleaning can be very effective and that the additional capital cost can often be justified in terms of reduced operating costs. Furthermore the way in which the additional area is accommodated, can affect the rate of fouling. For instance if the additional area results say, in reduced velocities, the fouling rate may be higher than anticipated and the value of the additional area may be largely offset by the effects of heavy deposits. The indiscriminate use of excess surface area for instance, can lead to high capital costs, especially where exotic and expensive materials of construction are required.

### **Additional Operating Costs**

The presence of fouling on the surface of heat exchangers decreases the ability of the unit to transfer heat. Due to this decrement in the exchanger thermal capacity, neither the hot stream nor the cold stream will approach its target temperature. To compensate this shortage in the heat flow, either additional cooling utility or additional heating utility is required. On the other hand, the presence of deposits on the surface of heat exchangers increases the pressure drop and to recover this increment, an additional pumping work is required and hence a greater pumping cost. Also the fouling may be the cause of additional maintenance costs. The more obvious result of course, is the need to clean the heat exchanger to return it to efficient operation. Not only will this involve labour costs but it may require large quantities of cleaning chemicals and there may be effluent problems to be overcome that add to the cost. If the cleaning agents are hazardous or toxic, elaborate safety precautions with attendant costs, may be required.

The frequent need to dismantle and clean a heat exchanger can affect the continued integrity of the equipment, i.e. components in shell and tube exchangers such as baffles and tubes may be damaged or the gaskets and plates in plate heat exchangers may become faulty. The damage may also aggravate the fouling problem by causing restrictions to flow and upsetting the required temperature distribution.

### **Loss of Production**

The need to restore flow and heat exchanger efficiency will necessitate cleaning. On a planned basis the interruptions to production may be minimized but even so if the remainder of the plant is operating correctly then this will constitute a loss of output that, if the remainder of the equipment is running to capacity still represents a loss of profit and a reduced contribution to the overall costs of the particular site. The consequences of enforced shutdown due to the effects of fouling are of course much more expensive in terms of output. Much depends on recognition of the potential fouling at the design stage so that a proper allowance is made to accommodate a satisfactory cleaning cycle. When the seriousness of a fouling problem goes unrecognized during design then unscheduled or even emergency shutdown, may be necessary. Production time lost through the need to clean a heat exchanger can never be recovered and it could in certain situations, mean the difference between profit and loss.

### **The Cost of Remedial Action**

If the fouling problem cannot be relieved by the use of additives it may be necessary to make modifications to the plant. Modification to allow on-line cleaning of a heat exchanger can represent a considerable capital investment. Before capital can be committed in this way, some assessment of the effectiveness of the modification must be made. In some examples of severe fouling problems the decision is straightforward, and a pay back time of less than a year could be anticipated. In other examples the decision is more complex and the financial risks involved in making the modification will have to be addressed. A number of contributions to the cost of fouling have been identified, however some of the costs will remain hidden. Although the cost of cleaning and loss of production may be recognized and properly assessed, some of the associated costs may not be attributed directly to the fouling problem. For instance the cost of additional maintenance of ancillary equipment such as pumps and pipework, will usually be lost in the overall maintenance charges.

## 7. Parameters affecting fouling

The fouling process is a dynamic and unsteady one in which many operational and design variables have been identified as having most pronounced and well defined effects on fouling. These variables are reviewed in principle to clarify the fouling problems and because the designer has an influence on their modification. Those parameters include the fluid flow velocity, the fluid properties, the surface temperature, the surface geometry, the surface material, the surface roughness, the suspended particles concentration and properties, .....etc. According to many investigators, the most important parameters are:

### 1. Fluid flow velocity

The flow velocity has a strong effect on the fouling rate where it has direct effects on both of the deposition and removal rates through the hydrodynamic effects such as the eddies and shear stress at the surface. On the other hand, the flow velocity has indirect effects on deposit strength ( $\psi$ ), the mass transfer coefficient ( $k_m$ ), and the stickability ( $P$ ). It is well established that, increasing the flow velocity tends to increase the thermal performance of the exchanger and decrease the fouling rate. Uniform and constant flow of process fluids past the heat transfer surface favors less fouling. Foulants suspended in the process fluids will deposit in low-velocity regions, particularly where the velocity changes quickly, as in heat exchanger water boxes and on the shell side. Higher shear stress promotes dislodging of deposits from surfaces. Maintain relatively uniform velocities across the heat exchanger to reduce the incidence of sedimentation and accumulation of deposits.

### 2. Surface temperature

The effect of surface temperature on the fouling rate has been mentioned in several studies. These studies indicated that the role of surface temperature is not well defined. The literatures show that, "*increase surface temperature may increase, decrease, or has no effect on the fouling rates*". This variation in behavior does indicate the importance to improve our understanding about the effect of surface temperature on the fouling process,

A good practical rule to follow is to expect more fouling as the temperature rises. This is due to a "baking on" effect, scaling tendencies, increased corrosion rate, faster reactions, crystal formation and polymerization, and loss in activity by some antifoulants [6]. Lower temperatures produce slower fouling buildup, and usually deposits that are easily removable [7]. However, for some process fluids, low surface temperature promotes crystallization and solidification fouling. To overcome these problems, there is an *optimum surface temperature* which better to use for each situation. For cooling water with a potential to scaling, the desired maximum surface temperature is about 60°C. Biological fouling is a strong function of temperature. At higher temperatures, chemical and enzyme reactions proceed at a higher rate with a consequent increase in cell growth rate [8]. According to Mukherjee [8], for any biological organism, there is a temperature below which reproduction and growth rate are arrested and a temperature above which the organism becomes damaged or killed. If, however, the temperature rises to an even higher level, some heat sensitive cells may die.

### 3. Surface material

The selection of surface material is significant to deal with corrosion fouling. Carbon steel is corrosive but least expensive. Copper exhibits biocidal effects in water. However, its use is limited in certain applications: (1) Copper is attacked by biological organisms including

sulfate-reducing bacteria; this increases fouling. (2) Copper alloys are prohibited in high-pressure steam power plant heat exchangers, since the corrosion deposits of copper alloys are transported and deposited in high-pressure steam generators and subsequently block the turbine blades. (3) Environmental protection limits the use of copper in river, lake, and ocean waters, since copper is poisonous to aquatic life. Noncorrosive materials such as titanium and nickel will prevent corrosion, but they are expensive and have no biocidal effects. Glass, graphite, and teflon tubes often resist fouling and/or improve cleaning but they have low thermal conductivity. Although the construction material is more important to resist fouling, surface treatment by plastics, vitreous enamel, glass, and some polymers will minimize the accumulation of deposits.

#### 4. Surface Roughness

The surface roughness is supposed to have the following effects: (1) The provision of "nucleation sites" that encourage the laying down of the initial deposits. (2) The creation of turbulence effects within the flowing fluid and, probably, instabilities in the viscous sublayer. Better surface finish has been shown to influence the delay of fouling and ease cleaning. Similarly, non-wetting surfaces delay fouling. Rough surfaces encourage particulate deposition and provide a good chance for deposit sticking. After the initiation of fouling, the persistence of the roughness effects will be more a function of the deposit itself. Even smooth surfaces may become rough in due course due to scale formation, formation of corrosion products, or erosion.

#### 5. Fluid Properties

The fluid propensity for fouling is depending on its properties such as viscosity and density. The viscosity is playing an important rule for the sublayer thickness where the deposition process is taking place. On the other side the viscosity and density have a strong effect on the shear stress which is the key element in the removal process.

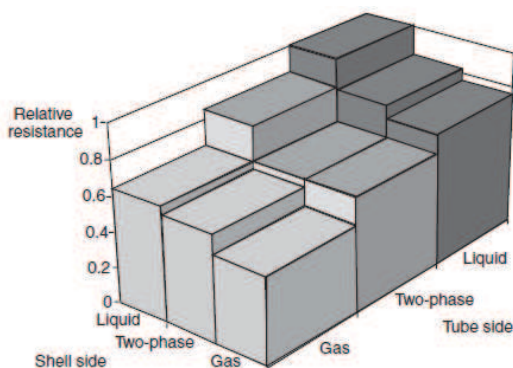

Fig. 5. Effect of the flow fluid type on the fouling

To show the effect of the flow fluid type on the fouling resistance, Chenoweth [7] collected data from over 700 shell and-tube heat exchangers. These data of combined shell- and tube-side fouling resistances (by summing each side entry), have been compiled and divided into nine combinations of liquid, two-phase, and gas on each fluid side regardless of the applications. The arithmetic average of total  $R_f$  of each two-fluid combination value has been taken and analyzed. The results are presented in Fig. (5) with ordinate ranges between 0 and

1.0. From this figure, it is clear that the maximum value is 1.0, that is due to liquid-liquid heat exchanger, where the minimum value is 0.5 which belong to gas-gas heat exchanger. If liquid is on the shell side and gas on the tube side, the relative fouling resistance is 0.65. However, if liquid is on the tube side and gas on the shell side, it is 0.75. Since many process industry applications deal with liquids that are dirtier than gases, the general practice is to specify larger fouling resistances for liquids compared to those for the gases. Also, if fouling is anticipated on the liquid side of a liquid-gas exchanger, it is generally placed in the tubes for cleaning purposes spite a larger fouling resistance is specified. These trends are clear from the figure. It should again be emphasized that Fig. (5) indicates the current practice and has no scientific basis. Specification of larger fouling resistances for liquids (which have higher heat transfer coefficients than those of gases) has even more impact on the surface area requirement for liquid-liquid exchangers than for gas-gas exchangers.

### 6. Impurities and Suspended Solids

Seldom are fluids pure. Intrusion of minute amounts of impurities can initiate or substantially increase fouling. They can either deposit as a fouling layer or acts as catalysts to the fouling processes [6]. For example, chemical reaction fouling or polymerization of refinery hydrocarbon streams is due to oxygen ingress and/or trace elements such as Va and Mo. In crystallization fouling, the presence of small particles of impurities may initiate the deposition process by seeding. The properties of the impurities form the basis of many antifoulant chemicals. Sometimes impurities such as sand or other suspended particles in cooling water may have a scouring action, which will reduce or remove deposits [9]. Suspended solids promote particulate fouling by sedimentation or settling under gravitation onto the heat transfer surfaces. Since particulate fouling is velocity dependent, prevention is achieved if stagnant areas are avoided. For water, high velocities (above 1 m/s) help prevent particulate fouling. Often it is economical to install an upstream filtration.

### 7. Heat Transfer Process

The fouling resistances for the same fluid can be considerably different depending upon whether heat is being transferred through sensible heating or cooling, boiling, or condensing.

### 8. Design Considerations

Equipment design can contribute to increase or decrease fouling. Heat exchanger tubes that extend beyond tube sheet, for example, can cause rapid fouling. Some fouling aspects must be considered through out the equipment design such as:

#### 1. Placing the More Fouling Fluid on the Tube Side

As a general guideline, the fouling fluid is preferably placed on the tube side for ease of cleaning. Also, there is less probability for low-velocity or stagnant regions on the tube side.

#### 2. Shell-Side Flow Velocities

Velocities are generally lower on the shell side than on the tube side, less uniform throughout the bundle, and limited by flow-induced vibration. Zero-or low-velocity regions on the shell side serve as ideal locations for the accumulation of foulants. If fouling is expected on the shell side, then attention should be paid to the selection of baffle design. Segmental baffles have the tendency for poor flow distribution if spacing or baffle cut ratio is not in correct proportions. Too low or too high a ratio results in an unfavorable flow regime that favors fouling.

### 3. Low-Finned Tube Heat Exchanger

There is a general apprehension that low Reynolds number flow heat exchangers with low-finned tubes will be more susceptible to fouling than plain tubes. Fouling is of little concern for finned surfaces operating with moderately clean gases. Fin type does not affect the fouling rate, but the fouling pattern is affected for waste heat recovery exchangers. Plain and serrated fin modules with identical densities and heights have the same fouling thickness increases in the same period of time.

### 4. Gasketed Plate Heat Exchangers

High turbulence, absence of stagnant areas, uniform fluid flow, and the smooth plate surface reduce fouling and the need for frequent cleaning. Hence the fouling factors required in plate heat exchangers are normally 10-25% of those used in shell and tube heat exchangers.

### 5. Spiral Plate Exchangers

High turbulence and scrubbing action minimize fouling on the spiral plate exchanger. This permits the use of low fouling factors.

### 6. Seasonal temperature changes

When cooling tower water is used as coolant, considerations are to be given for winter conditions where the ambient temperature may be near zero or below zero on the Celsius scale. The increased temperature driving force during the cold season contributes to more substantial overdesign and hence over performance problems, unless a control mechanism has been instituted to vary the water/air flow rate as per the ambient temperature. Also the bulk temperature of the cooling water that used in power condensers is changed seasonally. This change influences the fouling rate to some extent.

## 8. Fouling measurements and monitoring

The fouling resistances can be measured either experimentally or analytically. The main measuring methods include;

*1-Direct weighing;* the simplest method for assessing the extent of deposition on test surfaces in the laboratory is by direct weighing. The method requires an accurate balance so that relatively small changes in deposit mass may be detected. It may be necessary to use thin walled tube to reduce the tare mass so as to increase the accuracy of the method.

*2-Thickness measurement;* In many examples of fouling the thickness of the deposit is relatively small, perhaps less than  $50\ \mu\text{m}$ , so that direct measurement is not easy to obtain. A relatively simple technique provided there is reasonable access to the deposit, is to measure the thickness. Using a removable coupon or plate the thickness of a hard deposit such as a scale, may be made by the use of a micrometer or travelling microscope. For a deformable deposit containing a large proportion of water, e.g. a biofilm it is possible to use an electrical conductivity technique

*3-Heat transfer measurements;* In this method, the fouling resistance can be determined from the changes in heat transfer during the deposition process. The basis for subsequent operations will be Equation (14). The data may be reported in terms of changes in overall heat transfer coefficient. A major assumption in this method is that the presence of the deposit does not affect the hydrodynamics of the flowing fluid. However, in the first stages of deposition, the surface of the deposit is usually rougher than the metal surface so that the turbulence within the fluid is greater than when it is flowing over a smooth surface. As a result the fouling resistance calculated from the data will be lower than if the increased level of turbulence had been taken into account. It is possible that the increased turbulence offsets



the thermal resistance of the deposit and negative values of thermal resistance will be calculated.

*4-Pressure drop;* As an alternative to direct heat transfer measurements it is possible to use changes in pressure drop brought about by the presence of the deposit. The pressure drop is increased for a given flow rate by virtue of the reduced flow area in the fouled condition and the rough character of the deposit. The shape of the curve relating pressure drop with time will in general, follow an asymptotic shape so that the time to reach the asymptotic fouling resistance may be determined. The method is often combined with the direct measurement of thickness of the deposit layer. Changes in friction factor may also be used as an indication of fouling of a flow channel.

*5-Other techniques for fouling assessment;* In terms of their effect on heat exchanger performance the measurement of heat transfer reduction or increase in pressure drop provide a direct indication. The simple methods of measuring deposit thickness described earlier are useful, but in general they require that the experiment is terminated so as to provide access to the test sections. Ideally non-intrusive techniques would allow deposition to continue while the experimental conditions are maintained without disturbance. Such techniques include the use of radioactive tracers and optical methods. Laser techniques can be used to investigate the accumulation and removal of deposits. Also, infra red systems are used to investigate the development and removal of biofilms from tubular test sections. Microscopic examination of deposits may provide some further evidence of the mechanisms of fouling, but this is generally a "back up" system rather than to give quantitative data.

### **Gas-Side Fouling Measuring Devices**

The gas-side fouling measuring devices can be classified into five groups: heat flux meters, mass accumulation probes, optical devices, deposition probes, and acid condensation probes. A heat flux meter uses the local heat transfer per unit area to monitor the fouling. The decrease in heat flux as a function of time is thus a measure of the fouling buildup. A mass accumulation device measures the fouling deposit under controlled conditions. Optical measuring devices use optical method to determine the deposition rate. Deposition probes are used to measure the deposit thickness. Acid condensation probes are used to collect liquid acid that accumulates on a surface that is at a temperature below the acid dew point of the gas stream.

### **Instruments for Monitoring of Fouling**

Instruments have been developed to monitor conditions on a tube surface to indicate accumulation of fouling deposits and, in some cases, to indicate the effect on heat exchanger performance. The following is a summary of the different fouling monitors [10, 11]:

1. Removable sections of the fouled surface, which may be used for microscopic examination, mass measurements, and chemical and biological analysis of the deposits.
2. Increase in pressure drop across the heat exchanger length. This method provides a measure of fluid frictional resistance, which usually increases with buildup of fouling deposits. This device is relatively inexpensive and is easy to operate.
3. Thermal resistance monitors, which are used to determine the effect of the deposit on overall heat transfer resistance. The thermal method of monitoring has the advantage over the others of giving directly information that is required for predicting or assessing heat transfer performance.

## 9. Performance data analysis

As mentioned above, fouling has many effects on the heat exchanger performance. It decreases the exchanger thermal capacity and increases the pressure drop through the exchanger as shown in Fig. (6). From the figure it is clear that the total thermal resistance to heat transfer is decreased during the first stages of fouling due to the surface roughness resulting from initial deposition. After that and with deposits building up, the thermal resistance returns to increase again.

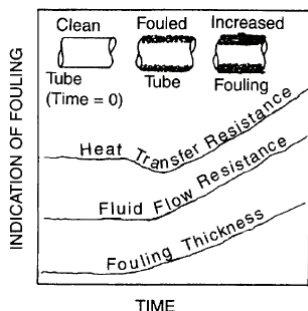

Fig. 6. Fouling effects on exchanger performance

In order to model and predict the industrial processes fouling problems it is first necessary to understand what is happening and what are the causes and effects of fouling. To achieve this, it is necessary to carefully examine and evaluate all the data and operating conditions at various plants in order to understand what the variables which are effective on fouling and what are the mechanisms of such phenomena. The objective of these efforts will be always to minimize the fouling clean-up / remediation shut-down frequency of the plants and to reduce the cost by making the minimum modification in the processes.

The possibility of whether the fouling material is a part of the feed to the system or it is a product of reaction / aggregation / flocculation in the system must be clarified. The role of various operating conditions in the system on fouling (pressures, temperatures, compositions, flow rates, etc. and their variations) must be understood and quantified. Only with appropriate modeling considering all the possible driving forces and mechanisms of fouling one may be able to predict the nature of fouling in each case and develop mitigation techniques to combat that.

The available fouling history data would be useful to test the packages which will be developed. Considering the diversity of the data, care must be taken in their analysis for any universality conclusions. However, in order to make comparisons between fouling data from various plants and test the accuracy of the developed packages, it will be necessary to acquire the compositions data of the feed in each plant as well as characteristics and conditions of operations of the process system used in those plants. Only then one can test the accuracy of the models developed and understand why in one case there is fouling and no fouling in another case.

Empirical data for fouling resistances have been obtained over many decades by industry since its first compilation by TEMA in 1941 for shell-and-tube heat exchangers. TEMA fouling resistances [12] are supposed to be representative values, asymptotic values, or those manifested just before cleaning to be performed.

It should be reiterated that the recommended fouling resistances are believed to represent typical fouling resistances for design. Consequently, sound engineering judgment has to be made for each selection of fouling resistances, keeping in mind that actual values of fouling resistances in any application can be either higher or lower than the resistances calculated. Finally, it must be clear that fouling resistances, although recommended following the empirical data and a sound model, are still constant, independent of time, while fouling is a transient phenomenon. Hence, the value of  $R_f$  selected represents a correct value only at one specific time in the exchanger operation. Therefore, it needs to be emphasized that the tables may not provide the applicable values for a particular design. They are only intended to provide guidance when values from direct experience are unavailable. With the use of finite fouling resistance, the overall U value is reduced, resulting in a larger surface area requirement, larger flow area, and reduced flow velocity which inevitably results in increased fouling. Thus, allowing more surface area for fouling in a clean exchanger may accelerate fouling initially.

Typical fouling resistances are roughly 10 times lower in plate heat exchangers (PHEs) than in shell-and-tube heat exchangers (TEMA values), (see Table 3).

Process Fluid	$R_f$ ( $\text{m}^2 \cdot \text{K}/\text{kW}$ )	
	PHEs	TEMA
Soft water	0.018	0.18–0.35
Cooling tower water	0.044	0.18–0.35
Seawater	0.026	0.18–0.35
River water	0.044	0.35–0.53
Lube oil	0.053	0.36
Organic solvents	0.018–0.053	0.36
Steam (oil bearing)	0.009	0.18

Table 3. Liquid-Side Fouling Resistances for PHEs vs. TEMA Values (from Ref.13)

## 10. Fouling models

Fouling is usually considered to be the net result of two simultaneous processes: a deposition process and a removal process. A schematic representation of fouling process is given in Fig. (1). Mathematically, the net rate of fouling can be expressed as the difference between the deposition and removal rates as given in equation (1). Many attempts have been made to model the fouling process. One of the earliest models of fouling was that by Kern and Seaton [14]. In this model, it was assumed that the rate of deposition mass,  $\dot{m}_d$ , remained constant with time  $t$  but that the rate of removal mass,  $\dot{m}_r$ , was proportional to the accumulated mass,  $m_f$ , and therefore increased with time to approach  $\dot{m}_d$  asymptotically. Thus

Rate of accumulation = Rate of deposition - Rate of removal

$$dm_f/dt = \dot{m}_d - \dot{m}_r \quad (4)$$

then integration of Eqn. (4) from the initial condition  $m_f = 0$  at  $t = 0$  gives

$$m_f = m_f^*(1 - e^{-\beta t}) \quad (5)$$

where  $m_f^*$  is the asymptotic value of  $m_f$  and  $\beta = 1/t_c$ . The time constant  $t_c$  represents the average residence time for an element of fouling material at the heat transfer surface. Referring to Eqn. (2), Eqn. (5) can be expressed in terms of fouling resistance  $R_f$  at time  $t$  in terms of the asymptotic value  $R_f^*$  by

$$R_f = R_f^*(1 - e^{-\beta t}) \quad (6)$$

It is obvious that the real solution would be to find expressions for  $R_f^*$  and  $t_c$  as a function of variables affecting the fouling process.

The purpose of any fouling model is to assist the designer or indeed the operator of heat exchangers, to make an assessment of the impact of fouling on heat exchanger performance given certain operating conditions. Ideally a mathematical interpretation of Eqn. (6) would provide the basis for such an assessment but the inclusion of an extensive set of conditions into one mathematical model would be at best, difficult and even impossible.

Modeling efforts to produce a mathematical model for fouling process have been based on the general material balance given in Eqn. (4) and centered on evaluating the functions  $\dot{m}_d$  and  $\dot{m}_r$  for specific fouling situations, some of these models are:

#### Watkinson Model:

Watkinson [15] reported the effect of fluid velocity on the asymptotic fouling resistance in three cases as;

1. Calcium carbonate scaling (with constant surface temperature and constant composition)

$$R_f^* = 0.101 / (v^{1.33} \cdot D^{0.23}) \quad (7)$$

2. Gas oil fouling (with constant heat flux)

$$R_f^* = 0.55 / v^2 \quad (8)$$

3. Sand deposition from water (with constant heat flux)

$$R_f^* = 0.015 / v^{1.2} \quad (9)$$

where;

$R_f^*$  the asymptotic fouling resistance

$v$  the fluid velocity

$D$  the tube diameter

#### Taborek, et al. Model:

Taborek, et al [16] introduced a water characterization factor to the deposition term to account for the effect of water quality. The deposition term, also involves two processes; (1) Diffusion of the potential depositing substance to the surface and (2) Bonding at the surface. They expressed the deposition rate in an arrhenius type equation as the following:

$$\Phi_d = k_1 P_d \Omega^n \exp\left(\frac{-E_a}{R_g T_s}\right) \quad (10)$$

where

- $k_1$  deposition constant
- $P_d$  deposition probability factor related to velocity and "Stickiness" or adhesion characteristics of the deposit,
- $n$  exponent
- $\Omega$  water characterization factor,
- $(-E_a/R_g T_s)$  the Arrhenius reaction rate function,
- $E_a$  the activation energy,
- $R_g$  the universal gas constant,
- $T_s$  the absolute surface temperature

In this model, the removal rate was postulated to be a function of shear stress, deposit thickness and bonding strength of the deposit. The removal function was given as:

$$\Phi_r = k_2 \left( \frac{\tau}{\psi} \right) x_f \tag{11}$$

where;

- $k_2$  removal constant
- $\tau$  the fluid shear stress exerted on the deposit surface
- $\psi$  the strength or toughness of the deposit layer

Substituting for the deposition rate (Eqn.10) and removal rate (Eqn.11) into material balance Eqn. (1) and taking into account Eqn. (3), the resulting equation yields to;

$$R_f = \frac{x_f}{\lambda_f} = \frac{k_1 P_d \Omega^n e^{-E_a/R_g T_s} (1 - e^{-k_2 \lambda_f \tau / \psi})}{\frac{k_2 \tau \lambda_f}{\psi}} \tag{12}$$

and

$$R_f^* = \frac{k_1 P_d \Omega^n e^{-E_a/R_g T_s}}{\frac{k_2 \tau \lambda_f}{\psi}}, \quad \beta = \frac{k_2 \lambda_f \tau}{\psi} = \frac{1}{t_c} \tag{13}$$

**Knudsen Analysis [17]:**

As it is known, the fouling process is complicated and dynamic. The fouling resistance is not usually measured directly, but must be determined from the degradation of the overall heat transfer coefficient. The fouling factor,  $R_f$ , could be expressed as;

$$R_f = \frac{1}{U_f} - \frac{1}{U_c} \tag{14}$$

Experimental fouling data have been analyzed on the basis of the change in overall heat transfer coefficient of the fouling test section as in equation (16). It is assumed that the thermal hydraulic condition in the test section remains reasonably constant for the duration of the fouling test. The model of Taborek et al. is used and the two parameters  $R_f^*$  and  $t_c$  can be determined for each fouling situation, where;

$R_f^*$  is the asymptotic fouling resistance contains all the factors that influence fouling.

$t_c$  is the time constant of the fouling resistance exponential curve i.e. the time required for the fouling resistance to reach 63% of its asymptotic value (i.e.  $t_c \approx 0.63t^*$ , see Fig. 3), it depends on the shear stress, the deposit strength factor and the deposit thermal conductivity as;

$$t_c = \psi / \tau k_2 \lambda_f \quad (15)$$

From the deposition - removal model, which was first presented by Kern and Seaton [13] (Eqn. 6) and from Eqn. (14), the overall heat transfer coefficient of the fouled surface.  $U_f$ , may be given as;

$$U_f = \frac{U_c}{1 + U_c R_f} \quad (16)$$

then

$$U_f = \frac{1}{\frac{1}{U_c} + R_f^* (1 - e^{-t/t_c})} \quad (17)$$

In equation (17), if the two coefficients  $R_f^*$  and  $t_c$  can be obtained accurately either empirically or analytically, they will be useful for predicting the fouling factor which can be used in practical heat exchanger design.

## 11. Fouling and heat exchanger design

The heat exchanger designer must consider the effect of fouling upon the exchanger performance during the desired operational lifetime and make provision in his design for sufficient extra capacity to insure that the exchanger will meet process specifications up to shutdown for cleaning. The designer must also consider what suitable arrangements are necessary to permit easy cleaning.

In choosing the fouling resistances to be used in a given heat exchanger, the designer has three main sources:

1. Past experience of heat exchanger performance in the same or similar environments.
2. Results from portable test rigs.
3. TEMA values, which are overall values for a very limited number of environments (table 4).

As it is known, the overall thermal resistance for a heat exchanger involves a series of thermal resistances from the hot fluid to the cold fluid, including thermal resistances due to fouling on both fluid sides, as shown in Fig. (7). Based on the inside heat transfer surface area  $A_i$ , the overall heat transfer coefficient is expressed as:

$$\frac{1}{U_i} = \left( \frac{1}{h_i} + R_{f,i} \right) + \frac{\delta_w}{\lambda_w} \frac{A_i}{A_w} + \left( \frac{1}{h_o} + R_{f,o} \right) \frac{A_i}{A_o} \quad (18)$$

In Eqn. (18), it is assumed that the wall thermal resistance is for a flat plate wall. This equation can be rearranged and simplified as

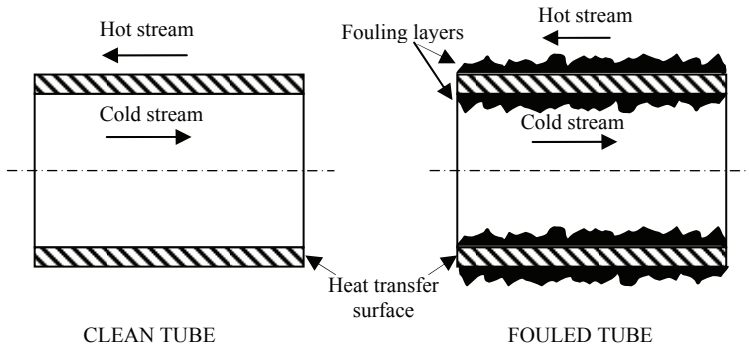

Fig. 7. Thermal resistances for clean and fouled tubes

$$\frac{1}{U_i} = \frac{1}{h_i} + R_{f,i} + R_{f,o} \frac{A_i}{A_o} + \frac{\delta_w}{\lambda_w} \frac{A_i}{A_w} + \frac{1}{h_o} \frac{A_i}{A_o} = \frac{1}{h_i} + R_f + R_w \frac{A_i}{A_w} + \frac{1}{h_o} \frac{A_i}{A_o} \tag{19}$$

Note that  $R_f=R_{f,i}+R_{f,o}(A_i/A_o)$  represents the total fouling resistance, a sum of fouling resistances on both sides of the heat transfer surface, as shown. It should again be reiterated that the aforementioned reduction in the overall heat transfer coefficient due to fouling does not take into consideration the transient nature of the fouling process.

The current practice is to assume a value for the fouling resistance on one or both fluid sides as appropriate and to design a heat exchanger accordingly by providing extra surface area for fouling, together with a cleaning strategy. The complexity in controlling a large number of internal and external factors of a given process makes it very difficult to predict the fouling growth as a function of time using deterministic (well-known) kinetic models.

A note of caution is warranted at this point. There is an ongoing discussion among scholars and engineers from industry as to whether either fouling resistance or fouling rate concepts should be used as the most appropriate tool in resolving design problems incurred by fouling. One suggestion in resolving this dilemma would be that the design fouling-resistance values used for sizing heat exchangers be based on fouling-rate data and estimated cleaning-time intervals.

In current practice, based on application and need, the influence of fouling on exchanger heat transfer performance can be evaluated in terms of either (1) required increased surface area for the same  $q$  and  $\Delta T_m$ , (2) required increased mean temperature difference for the same  $q$  and  $A$ , or (3) reduced heat transfer rate for the same  $A$  and  $\Delta T_m$ . For these approaches, the expressions;  $A_f / A_c$ ,  $\Delta T_{m,f} / \Delta T_{m,c}$  and  $q_f / q_c$  may be determined. In the first two cases, the heat transfer rate in a heat exchanger under clean and fouled conditions are the same. Hence,

$$q = U_c A_c \Delta T_m = U_f A_f \Delta T_m \quad (\text{for constant } \Delta T_m) \tag{20}$$

Therefore,

$$\frac{A_f}{A_c} = \frac{U_c}{U_f} \tag{21}$$

Where, the subscript  $c$  denotes a clean surface and  $f$  the fouled surface.

It must be noted that, the first case of the above mentioned approaches is the design of an exchanger where an allowance for fouling can be made at the design stage by increasing surface area, while the other two cases are for an already designed exchanger in operation, and the purpose is to determine the impact of fouling on exchanger performance.

According to Eqn. (19), the relationships between overall heat transfer coefficients (based on tube outside surface area) and thermal resistances for clean and fouled conditions are defined as follows. For a clean heat transfer surface,

$$\frac{1}{U_c} = \frac{1}{h_{o,f}} + R_w \frac{A_o}{A_w} + \frac{1}{h_{i,f}} \frac{A_o}{A_i} \quad (22)$$

For a fouled heat transfer surface,

$$\frac{1}{U_f} = \frac{1}{h_{o,f}} + R_f + R_w \frac{A_o}{A_w} + \frac{1}{h_{i,f}} \frac{A_o}{A_i} = \frac{1}{h_{o,f}} + R_f + R_w \frac{A_o}{A_w} + \frac{1}{h_{i,c}} \frac{A_o}{A_i} \quad (23)$$

For the ideal conditions that,  $h_{o,f} = h_{o,c}$ ,  $h_{i,f} = h_{i,c}$ ,  $A_{i,f} = A_{i,c} = A_i$  and  $A_{o,f} = A_{o,c} = A_o$ , the difference between Eqns. (22) and (23) yields to Eqn. (14) which is

$$R_f = \frac{1}{U_f} - \frac{1}{U_c} \quad (14)$$

Combining Eqns. (14) and (21), it gets

$$\frac{A_f}{A_c} = U_c R_f + 1 \quad (24)$$

Similarly, when  $q$  and  $A$  are the same and  $\Delta T_m$  is different for clean and fouled exchangers, it has

$$q = U_c A_c \Delta T_{m,c} = U_f A_c \Delta T_{m,f} \quad (\text{for constant } A) \quad (25)$$

Hence,

$$\frac{\Delta T_{m,f}}{\Delta T_{m,c}} = \frac{U_c}{U_f} \quad (26)$$

Combining Eqns. (14) and (26), it gets

$$\frac{\Delta T_{m,f}}{\Delta T_{m,c}} = U_c R_f + 1 \quad (27)$$

Finally, if one assumes that heat transfer area and mean temperature differences are fixed, heat transfer rates for the same heat exchanger under fouled and clean conditions are given by  $q_f = U_f A \Delta T_m$  and  $q_c = U_c A \Delta T_m$ , respectively. Combining these two relationships with Eqn. (14), it gets



$$\frac{q_f}{q_c} = \frac{1}{U_c R_f + 1} \quad (28)$$

Alternatively, Eqn. (28) can be expressed as

$$\frac{q_c}{q_f} = U_c R_f + 1 \quad (29)$$

It is important to be noted that, the right-hand sides of Eqns. (24), (27) and (29) are the same. From this set of equations, it can be concluded that, the percentage increment in  $A$  and  $\Delta T_m$  and the percentage reduction in  $q$  due to the presence of fouling are increased by increasing  $U_c$  and/or  $R_f$ . For this reason and to mitigate and attenuate the effects of fouling, the heat exchanger must be operated with low  $U_c$ . That is completely contrary to the well postulated conceptions in the field of heat exchangers design that mostly recommend using high values of  $U_c$ . As an example for this fact, in Eqn. (24), if  $R_f$  is of order  $4 \times 10^{-4} \text{ m}^2 \cdot \text{K}/\text{W}$ , and  $U_c$  of order  $1000 \text{ W}/\text{m}^2 \cdot \text{K}$ , then the excess surface area will be 40%, where this excess ratio will be reduced to only 20% if the  $U_c$  was  $500 \text{ W}/\text{m}^2 \cdot \text{K}$  with the same  $R_f$ . Therefore, the low overall heat transfer coefficients have been used in some processes in which the fouling resistances are severe such as petrochemical industries to avoid the fouling impact on the exchanger performance. Another important factor which related to the fouling resistance is the cleanliness factor, CF and is given as

$$CF = \frac{U_f}{U_c} = \frac{1}{U_c R_f + 1} \quad (30)$$

TEMA fouling resistance values [12] for water and other fluids are given in Table (4).

Fluid	Fouling Resistance ( $10^4$ $\text{m}^2 \cdot \text{K}/\text{W}$ )	Fluid	Fouling Resistance ( $10^4$ $\text{m}^2 \cdot \text{K}/\text{W}$ )
LIQUID WATER STREAMS		CHEMICAL PROCESS STREAMS	
Artificial spray pond water	1.75–3.5	Acid gas	3.5–5.3
Boiler blowdown water	3.5–5.3	Natural gas	1.75–3.5
Brackish water	3.5–5.3	Solvent vapor	1.75
Closed-cycle condensate	0.9–1.75	Stable overhead products	1.75
Closed-loop treated water	1.75	CRUDE OIL REFINERY	
Distilled water	0.9–1.75	STREAMS	
Engine jacket water	1.75	Temperature $\approx 120^\circ\text{C}$	3.5–7
River water	3.5–5.3	Temperature $\approx 120$ – $180^\circ\text{C}$	5.25–7
Seawater	1.75–3.5	Temperature $\approx 180$ – $230^\circ\text{C}$	7–9
Treated boiler feedwater	0.9	Temperature $> 230^\circ\text{C}$	9–10.5
Treated cooling tower water	1.75–3.5	PETROLEUM STREAMS	
INDUSTRIAL LIQUID		Lean oil	3.5
STREAMS		Liquefied petroleum gases	1.75–3
Ammonia (oil bearing)	5.25		

Engine lube oil	1.75	Natural gasolene	1.75-3.5
Ethanol	3.5	Rich oil	1.75-3.5
Ethylene glycol	3.5	PROCESS LIQUID STREAMS	
Hydraulic fluid	1.75	Bottom products	1.75-3.5
Industrial organic fluids	1.75-3.5	Caustic solutions	3.5
Methanol	3.5	DEA solutions	3.5
Refrigerants	1.75	DEG solutions	3.5
Transformer oil	1.75	MEA solutions	3.5
No. 2 fuel oil	3.5	TEG solutions	3.5
No. 6 fuel oil	0.9	CRUDE AND VACUUM	
CRACKING AND COKING		LIQUIDS	12.3
UNIT STREAMS		Atmospheric tower bottoms	3.5
Bottom slurry oils	5.3	Gasolene	5.3-12.3
Heavy coker gas oil	7-9	Heavy fuel oil	5.3-9
Heavy cycle oil	5.3-7	Heavy gas oil	3.5-5.3
Light coker gas oil	5.3-7	Kerosene	3.5-5.3
Light cycle oil	3.5-5.3	Light distillates and gas oil	3.5-5.3
Light liquid products	3.5	Naphtha	17.6
Overhead vapors	3.5	Vacuum tower bottoms	
LIGHT-END PROCESSING		INDUSTRIAL GAS OR VAPOR	
STREAMS		STREAMS	1.75
Absorption oils	3.5-5.3	Ammonia	3.5
Alkylation trace acid streams	3.5	Carbon dioxide	17.5
Overhead gas	1.75	Coal flue gas	1.75
Overhead liquid products	1.75	Compressed air	2.6-3.5
Overhead vapors	1.75	Exhaust steam (oil bearing)	9
Reboiler streams	3-5.5	Natural gas flue gas	3.5
		Refrigerant (oil bearing)	9
		Steam (non-oil bearing)	

Table 4. TEMA fouling resistance values for water and other fluids [12]

## 12. Heat exchanger cleaning

In most applications, fouling is known to occur in spite of good design, effective operation, and maintenance. Hence, heat exchangers and associated equipment must be cleaned to restore the heat exchanger to efficient operation. The time between cleaning operations will depend upon the severity of the fouling problem. In some instances, cleaning can be carried out during periodical maintenance programs (say, twice yearly or annually) but in other cases frequent cleaning will be required, perhaps as frequently as monthly or quarterly. For example, locomotive radiators are air blown during their fortnightly schedules.

### Cleaning Techniques [18-20]

In general, the techniques used to remove the foulants from the heat exchanger surfaces can be broadly classified into two categories: *mechanical cleaning* and *chemical cleaning*. The cleaning process may be employed while the plant is still in operation, that is named, *on-line* cleaning, but in most situations it will be necessary to shutdown the plant to clean the

heat exchangers, known as *off-line* cleaning. In some instances combinations of these cleaning methods may be necessary. Each method of cleaning has advantages and disadvantages with specific equipment types and materials of construction.

### Deposit Analysis

Information about the composition of fouling deposits through deposit analysis is extremely helpful to identify the source of the major foulants, to develop proper treatment, and as an aid in developing a cleaning method for a fouling control program. The sample should represent the most critical fouling area. For heat exchangers and boilers, this is the highest heat transfer area. Many analytical techniques are used to characterize deposit analysis. Typical methods include x-ray diffraction analysis, x-ray spectrometry, and optical emission spectroscopy.

### Selection of Appropriate Cleaning Method

Before attempting to clean a heat exchanger, the need should be carefully examined. Consider the following factors for selecting a cleaning method:

- Degree of fouling.
- Nature of the foulant, known through deposit analysis.
- The compatibility of the heat exchanger material and system components in contact with the cleaning chemicals (in the case of chemical cleaning which associated with pumping hot corrosives through temporary connections).
- Regulations against environmental discharges.
- Accessibility of the surfaces for cleaning.
- Cost factors.
- Precautions to be taken while undertaking a cleaning operation.

These precautions are listed in TEMA [12] as:

1. Individual tubes should not be steam blown because this heats the tube and may result in severe thermal strain and deformation of the tube, or loosening of the tube to tube sheet joint.
2. When mechanically cleaning a tube bundle, care should be exercised to avoid damaging the tubes. Tubes should not be hammered with a metallic tool.

### Off-Line Mechanical Cleaning

Techniques using mechanical means for the removal of deposits are common throughout the industry. The various off-line mechanical cleaning methods are

1. Manual cleaning
2. Jet cleaning
3. Drilling and Roding of tubes
4. Blasting
5. Soot blowing
6. Thermal cleaning
7. Turbining

#### 1. Manual Cleaning

Where there is good access, as with a plate or spiral heat exchanger, or a removable tube bundle, and the deposit is soft, hand scrubbing and washing may be employed, although the labor costs are high.

#### 2. Jet Cleaning

Jet cleaning or hydraulic cleaning with high pressure water jets can be used mostly on external surfaces where there is an easy accessibility for passing the high pressure jet. Jet washing can be used to clean foulants such as: (1) airborne contaminants of air-cooled exchangers at a

pressure of 2-4 bar, (2) soft deposits, mud, loose rust, and biological growths in shell and tube exchangers at a pressure of 40-120 bar, (3) heavy organic deposits, polymers, tars in condensers and other heat exchangers at a pressure of 300-400 bar, and (4) scales on the tube side and fire side of boilers, pre-heaters, and economizers at a pressure of 300-700 bar. This method consists of directing powerful water jets at fouled surfaces through special guns or lances. A variety of nozzles and tips is used to make most effective use of the hydraulic force. The effectiveness of this cleaning procedure depends on accessibility, and care is needed in application to prevent damage to the tubes and injury to the personnel. Similar to water jet cleaning, pneumatic descaling is employed on the fire side of coal-fired boiler tubes.

### 3. Drilling and Roding of Tubes

Drilling is employed for tightly plugged tubes and roding for lightly plugged tubes. Drilling of tightly plugged tubes is known as bulleting. For removing deposits, good access is required, and care is again required to prevent damage to the equipment. A typical example is roding of radiator tubes plugged by solder bloom corrosion products.

### 4. Blast Cleaning

Blast cleaning involves propelling suitable abrasive material at high velocity by a blast of air or water (hydroblasting) to impinge on the fouled surface. Hydroblasting is seldom used to clean tube bundles because the tubes are very thin. However, the technique is suitable to descale and clean tube-sheet faces, shells, channel covers, bonnets, and return covers inside and outside.

### 5. Soot Blowing

Soot blowing is a technique employed for boiler plants, and the combustion or flue gas heat exchangers of fired equipment. The removal of particles is achieved by the use of air or steam blasts directed on the fin side. Water washing may also be used to remove carbonaceous deposits from boiler plants. A similar cleaning procedure is followed for air blowing of radiators on the fin side during periodical schedule attention.

### 6. Thermal Cleaning

Thermal cleaning involves steam cleaning, with or without chemicals. This method is also known as hydrosteaming. It can be used to clean waxes and greases in condensers and other heat exchangers.

### 7. Turbining

Turbining is a tube-side cleaning method that uses air, steam, or water to send motor-driven cutters, brushes, or knockers in order to remove deposits.

## Merits and Demerits of Mechanical Cleaning

The merits of mechanical cleaning methods include simplicity and ease of operation, and capability to clean even completely blocked tubes. However, the demerits of this method may be due to the damage of the equipment, particularly tubes, it does not produce a chemically clean surface and the use of high pressure water jet or air jet may cause injury and/or accidents to personnel engaged in the cleaning operation hence the personnel are to be well protected against injuries.

## Chemical Cleaning

The usual practice is to resort to chemical cleaning of heat exchangers only when other methods are not satisfactory. Chemical cleaning involves the use of chemicals to dissolve or loosen deposits. The chemical cleaning methods are mostly off-line. Chemical cleaning methods must take into account a number of factors such as:

1. Compatibility of the system components with the chemical cleaning solutions. If required, inhibitors are added to the cleaning solutions.
2. Information relating to the deposit must be known beforehand.
3. Chemical cleaning solvents must be assessed by a corrosion test before beginning cleaning operation.
4. Adequate protection of personnel employed in the cleaning of the equipment must be provided.
5. Chemical cleaning poses the real possibility of equipment damage from corrosion. Precautions may be taken to reduce the corrosion rate to acceptable levels. On-line corrosion monitoring during cleaning is necessary. Postcleaning inspection is extremely important to check for corrosion damage due to cleaning solvents and to gauge the cleaning effectiveness.
6. Disposal of the spent solution.

### Chemical Cleaning Solutions

Chemical cleaning solutions include mineral acids, organic acids, alkaline bases, complexing agents, oxidizing agents, reducing agents, and organic solvents. Inhibitors and surfactant are added to reduce corrosion and to improve cleaning efficiency. Common foulants and cleaning solvents are given in Table (5) and common solvents and the compatible base materials are given in Table (6).

Foulant	Cleaning solvent
Iron oxides	Inhibited hydrofluoric acid, hydrochloric acid, monoammoniated citric acid or sulfamic acid, EDTA
Calcium and magnesium scale	Inhibited hydrochloric acid, citric acid, EDTA
Oils or light greases	Sodium hydroxide, trisodium phosphate with or without detergents, water-oil emulsion
Heavy organic deposits such as tars, asphalts, polymers	Chlorinated or aromatic solvents followed by a thorough rinsing
Coke/carbonaceous deposits	Alkaline solutions of potassium permanganate or steam air decoking

Table 5. Foulants and Common Solvents [2]

### General Procedure for Chemical Cleaning

The majority of chemical cleaning procedures follow these steps:

1. Flush to remove loose debris.
2. Heating and circulation of water.
3. Injection of cleaning chemical and inhibitor if necessary in the circulating water.
4. After sufficient time, discharge cleaning solution and flush the system thoroughly.
5. Passivate the metal surfaces.
6. Flush to remove all traces of cleaning chemicals.

It is suggested that one employ qualified personnel or a qualified organization for cleaning services.

Solvent	Base metal/foulant
Hydrochloric acid	Water-side deposits on steels. Inhibited acid can be used for cleaning carbon steels, cast iron, brasses, bronzes, copper-nickels, and Monel 400. This acid is not recommended for austenitic stainless steels, Inconel600, Incoloy 800, and luminum.
Hydrofluoric acid	To remove mill scale.
Inhibited sulfuric acid	Carbon steel, austenitic stainless steels, copper-nickels, admiralty brass, aluminum bronze, and Monel 400. It should not be used on aluminum.
Nitric acid	Stainless steel, titanium, and zirconium.
Sulfamic acid	To remove calcium and other carbonate scales and iron oxides. Inhibited acid can be used on carbon steel, copper, admiralty brass, cast iron, and Monel400.
Formic acid with citric acid or HCl.	To remove iron oxide deposit. Can be used on stainless steels.
Acetic acid	To remove calcium carbonate scale.
Citric acid	To clean iron oxide deposit from aluminum or titanium.
Chromic acid	To remove iron pyrite and certain carbonaceous deposits that are insoluble in HCl on carbon steel and stainless steels. It should not be used on copper, brass, bronze, aluminum, and cast iron.

Table 6. Solvent and Compatible Base Metals [2]

### Off-Line Chemical Cleaning

Major off-line chemical cleaning methods are

1. Circulation
2. Acid cleaning
3. Fill and soak cleaning
4. Vapor-phase organic cleaning
5. Steam injection cleaning

1) *Circulation*; This method involves the filling of the equipment with cleaning solution and circulating it by a pump. While cleaning is in progress, the concentration and temperature of the solution are monitored.

2) *Acid Cleaning*; Scales due to cooling water are removed by circulating a dilute hydrochloric acid solution. This is discussed in detail with the discussion of cooling-water fouling.

3) *Fill and Soak Cleaning*; In this method, the equipment is filled with a chemical cleaning solution and drained after a period of time. This may be repeated several times until satisfactory results are achieved. However, this method is limited to small units only.

4) *Vapor-Phase Organic Cleaning*; This method is used to remove deposits that are organic in nature.

5) *Steam Injection Cleaning*; This method involves an injection of a concentrated mix of cleaning solution and steam into a fast-moving stream. The steam atomizes the chemicals, increasing their effectiveness and ensuring good contact with metal surfaces.

### Merits of Chemical Cleaning

Chemical cleaning offers the following advantages over the mechanical cleaning:

1. Uniform cleaning and sometimes complete cleaning.
2. Sometimes chemical cleaning is the only possible method.

3. No need to dismantle the unit, but it must be isolated from the system.
4. Capable of cleaning inaccessible areas.
5. Moderate cleaning cost and longer intervals between cleaning.

### Demerits of Chemical Cleaning

Chemicals used for cleaning are often hazardous to use and require elaborate disposal procedures. Noxious gases can be emitted from the cleaning solution from unexpected reactions. Chemical cleaning corrodes the base metal and the possibility of excess corrosion cannot be ruled out. Complete washing of the equipment is a must to eliminate corrosion due to residual chemicals.

### On-Line Cleaning Methods

There is an obvious need for an industrial on-line cleaning procedure that can remove fouling deposits without interfering with a plant's normal operation. On-line cleaning methods can be either mechanical or chemical. On-line chemical cleaning is normally achieved by dosing with chemical additives.

### On-Line Mechanical Cleaning Methods

Various on-line mechanical cleaning methods to control fouling in practice are:

1. Upstream filtration
2. Flow excursion
3. Air bumping of heat exchangers
4. Reversing flow in heat exchangers
5. Passing brushes through exchanger tubes
6. Sponge rubber balls cleaning system
7. Brush and cage system
8. Grit cleaning
9. Use of inserts
10. Self-cleaning fluidized-bed exchangers
11. Magnetic devices
12. Use of sonic technology

1) *Upstream filtration (Debris Filter)*; Cooling water fouling can be controlled, and in some cases eliminated, by adequately filtering the intake water. Power station condensers are more vulnerable to the intake of debris and biological organisms. One solution to prevent the blockage of condenser tubes is the installation of an upstream filtration system. All particles in the cooling water larger than 10 mm are kept in the filter and rinsed away through the debris discharge.

2) *Flow excursion*; in this method the instantaneous flow is increased to remove the fouling deposits. This method is particularly applicable to a heat exchanger fouled badly due to the effects of low velocity either on the shell side or the tube side.

3) *Air bumping*; this technique involves the creation of slugs of air, thereby creating localized turbulence as slugs pass through the equipment. The technique has been applied to the liquid system on the shell side of heat exchangers. Care has to be taken to avoid the possibility of producing explosive mixtures of gases if the process fluid is volatile and flammable.

4) *Reversing flow in heat exchangers*; this is followed on the water side of the cooling water system by intermittent reversal of flow and intermittent air injection.

5) *Passing brushes through exchanger tubes*; the ram brush has been developed to clean fouled heat exchanger tubes. The unit consists of a 2.5-in long plastic dowel wrapped with 1.5-in nylon bristles. The brushes are propelled through the tube by an air and water gun and shot right through the tube. Water pressure of 0.3-4.0 bar and air pressure of 6.0-7.0 bar are sufficient to send the ram brush through standard heat exchanger tubes.

6) *Sponge rubber ball cleaning system*; A large number of sponge rubber balls, slightly larger in diameter than the inner diameter of the tubes and having about the same specific gravity as sea water, are passed continuously into the inlet water box (for instance, the Amertap or Taprogge system). The cooling water flow forces the balls through the tubes and the deposits on the tube walls are wiped out. The method may not be effective on longer runs once hard deposits are formed, or pitted. The balls used for normal operation should have the right surface roughness to gently clean the tubes, without scoring the tube surface. To remove heavy deposits, special abrasive balls that have a coating of carborundum are available.

7) *Brush and cage system*; The brush and cage or the Mesroc automatic on-load tube cleaning system used for cleaning heat exchangers consists of cleaning sets each containing two baskets and a brush, all within the tubes of the heat exchanger. The baskets are fixed to the ends of the heat exchanger tubes and every tube has its own brush. By reversing the flow direction, every brush is being moved from one end of the tube to the other, where it is retained by the basket. The brushes moving to and fro keep the inner walls clean. An actuator and a control system initiate the cleaning cycles. A major advantage of the system is that it does not require a recirculation system as for rubber ball system and an important disadvantage is the interruption of the flow in the heat exchanger and consequent disturbance of steady state conditions. Unlike the rubber ball circulation system, the brush and cage system has not been used to any extent in power plant condensers. However, it has been applied to single exchangers in process industries.

8) *Grit cleaning*; in this method, abrasive material, such as sand, glass, or metal spheres, is passed through the tubes. The scouring action removes the deposits from the inside of the tubes. The method has found application in cooling water systems, but it could be used in conjunction with any fouling fluids. A special grit blasting nozzle accelerates the grit and causes it to follow a sinusoidal path through the tube, dislodging the deposits. Velocities more than 3 m/s are probably required for the technique to be effective.

9) *Use of inserts*; Inserts, as a means of heat transfer augmentation device, located on the inside of tubes, often reduce the incidence of fouling. Wire-wound inserts and twisted tape turbulence promoters have been found to reduce fouling by vibrating axially and radially under the influence of the fluid motion. However, in some instances with the use of wire-wound inserts, the fouling rate has increased with excessive pressure drop due to accumulation of deposits on wire inserts.

10) *Self-cleaning fluidized-bed exchangers*; A variation of the abrasive cleaning method is to use a fluidized bed of particles to control fouling on the outside or inside of tubular exchangers, known as self-cleaning exchangers. A fluidized-bed exchanger consists of a large number of parallel vertical tubes, in which small solid particles are kept in a fluidized condition by the liquid velocities. The particles have a slightly abrasive effect on the tube walls, so that they remove the deposits. A typical example for fin-side foulant control is the fluidized-bed waste heat recovery (FBWHR) heat exchanger used to preheat combustion air for industrial furnaces. Fluidized-bed heat exchangers consists of horizontal finned heat exchanger tubes with a shallow bed of fine inert particles, which move upward with gas flow and give up heat to the finned tubes. Similarly on the tube side, the fine particles scrub the tube surfaces to minimize fouling deposit.

11) *Magnetic devices*; the use of magnetic fields to reduce or eliminate scale formation in pipes has been attempted for many years. It could be supposed that slightly soluble compounds



such as  $\text{CaCO}_3$  existing in solution as charged ions, would be affected by the application of an electric field, and that this could form the basis of a technique to alleviate fouling.

12) *Use of sonic technology*; the principle underlying the application of sound is that the vibration created by the energy associated with the transmission of sound will disturb and dislodge deposits on surfaces, i.e. "to shake" the deposit free. Cavitation produced by the propagation of sonic waves in the continuous phase near the deposit surface, can also assist the removal process. In general the technique has been used for problems in gas systems, particularly flue gases from combustors, i.e. very similar to the application of soot blowers.

#### **Merits of On-Line Cleaning**

The merits of on-line cleaning are that it

1. Is more convenient.
2. Does not require any plant shutdown.
3. Can save time and labor.

However, the initial cost may be very high in certain cases.

### **13. Fouling MITIGATION AND control**

Specifying the fouling resistances or oversizing result in added heat transfer surface, the excess surface area can result in problems during startup and bring about conditions that can, in fact, encourage excess fouling due to low velocity. There are a number of techniques that can overcome or mitigate the effects of fouling in heat exchangers, and they include, [21, 22]:

1. Designing the plant or process in such a way that the condition leading to the fouling is limited or reduced.
2. Instituting an on-line mechanical cleaning system, or cleaning the equipment when the effects of the fouling can no longer be tolerated to restore its effectiveness by various offline cleaning techniques.
3. The use of chemical additives or antifoulants in the fouling stream.

#### **Measures to Be Taken During the Design Stages**

No hard and fast rules can be applied for heat exchanger design in relation to fouling, but the following points should be kept in mind during the conception and design of a heat exchanger:

1. Make the design simple.
2. Select the heat exchanger type with point 1 in mind. Heat exchangers other than shell and tube units may be better suited to fouling applications. Gasketed plate exchangers and spiral plate exchangers offer better resistance to fouling because of increased turbulence, higher shear, or other factors. Before commissioning a heat exchanger, carry out design checks and ensure that all constructional details and clearances conform to specification.
3. Prevent the possibility of corrosion and fouling during and subsequent to hydrostatic testing.
4. Startup conditions should avoid temperatures higher or velocities lower than the design values.
5. Maximize the flow velocities of process fluids to enhance the removal of the fouling deposits, provided that the fluid velocity is not high enough to cause excessive pressure

- drop or flow induced vibration on the shell side. Ensure that velocities in tubes are in general above 2 m/s and about 1 m/s on the shell side. Avoid stagnant areas where the flow velocities are less than those in the bulk of the core.
6. Assume nominal fouling resistance either from past experience or from published standards and design the heat exchanger with nominal oversizing. The oversizing may be of the order of 20-40%. It is generally prudent to avoid large fouling factors, which result in larger equipment. Larger equipment generally results in lower velocities and hence may accelerate fouling.
  7. To minimize fouling of finned tube or plate fin heat exchangers, use optimum fin density. Otherwise the initial benefit of increased heat transfer will be offset by fouling in the long run. This is most appropriate for industrial air coolers, radiators of automobiles, and diesel locomotives. Compact heat exchangers functioning in outdoor unit are most prone to fouling due to airborne dirt, flying objects, leaves, and fibrous objects. Other considerations are in-line layouts to provide cleaning lanes for soot blowers, and wide pitches for dirty flue gases.
  8. Fouling fluid on the tube side: When the fouling fluid is on the tube side, there are some recommended measures such as (1) using larger diameter tubes (a minimum of 25 mm OD), (2) maintaining high velocity (for cooling water, a minimum velocity of 1.5 m/s for mild steel, 1.2 m/s for nonferrous tubes, and as high as 5 m/s for titanium tubes is recommended), (3) leaving sufficient margin in pressure drop (for high fouling services, leave a margin of 30-40% between the allowable and calculated pressure drop), (4) using a spare tube bundle or spare exchanger, (5) using two shells in parallel (each with 60-70% of total capacity), (6) using wire-fin tube inserts, and (7) using on-line cleaning methods.
  9. Fouling fluid on the shell side: When the fouling fluid is on the shell side, use a square or rotated square tube layout, minimize dead spaces by optimum baffle design, and maintain high velocity.
  10. If severe fouling is inevitable, it is frequently better to install spare units. Installed spares will permit cleaning while the other unit is in service.
  11. Proper selection of cooling medium can frequently avoid problems associated with fouling. For example, air cooling in place of cooling water solves many of the corrosion and fouling problems such as scaling, biological growth, and many of the aqueous corrosion. The cleaning of bare tube or finned tube surfaces fouled by air is easier than surfaces fouled by water.
  12. Particulate fouling, scaling, and trace-metal-catalyzed hydrocarbon reaction fouling can often be prevented by pretreatment of the feed streams to a heat exchanger by filtration, softening, and desalting, respectively.
  13. Once the unit is onstream, operate at the design conditions of velocity and temperature.

#### **14. Fouling in heat exchanger networks**

As mentioned in the previous sections, the presence of fouling in a unique heat exchanger has dramatically serious effects on its performance. In the case of heat exchanger networks (HEN), these effects become more dramatic in which they transferred from one exchanger to another growing up and multiplying through out the network. As an example for the effect of fouling on heat exchanger networks is as the following:

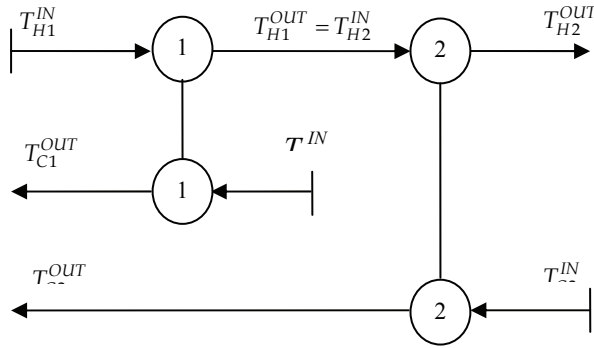

Fig. 8. section of a HEN shows the change in  $(T_{H2})^{OUT}$  due to the presence of fouling in exchangers (1) and (2).

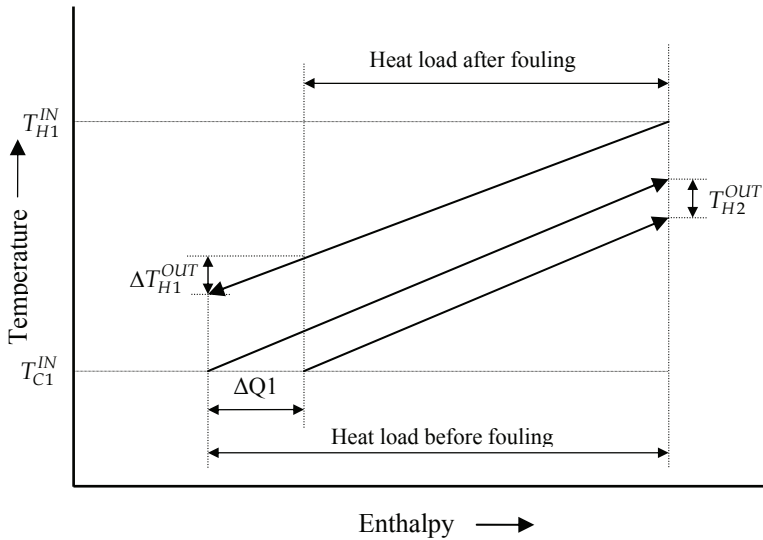

Fig. 9. Fouling effects on the outlet temperatures of cold and hot streams in a single heat exchanger (exchanger 1 in Fig. 8).

Figure (8) represents a part of a big HEN with two heat exchangers and four streams ( two cold and two hot). The presence of fouling in exchanger (1) will decrease the outlet temperature of cold stream (1) by  $(\Delta T_{C1})^{OUT}$ , as shown in Fig. (9), and will increase the outlet temperature of hot stream (1) by  $(\Delta T_{H1})^{OUT}$ . As  $(T_{H1})^{OUT} = (T_{H2})^{IN}$ , then the inlet temperature of hot stream (2),  $(T_{H2})^{IN}$ , will be changed by the value of  $(\Delta T_{H1})^{OUT}$  and subsequently the outlet temperature of hot stream (2) will also be changed due the fouling presents in exchanger(1). Beside to this effect, the presence of fouling in exchanger (2) will change the outlet temperature of hot stream (2). Therefore, the outlet temperature of hot stream (2) is affected by the presence of fouling in both heat exchangers, (For details, see Ref. 25).

## 15. Recently researches in the fouling area

Much research is in underway for fouling. This research will some day enable us to understand the parameters responsible for fouling and hence to devise means to control or eliminate fouling. Today, however, we largely rely upon experience.

Important cooperative research is being done by groups such as Heat Transfer Research, Inc. (USA), and the Heat Transfer and Fluid Flow Service (UK). May be in the near future, it is likely that a number of usable models will be available that are somewhat better than the TEMA fouling resistances.

By using the modern technologies and facilities, the recent researches in the fouling area are aimed to well understanding this phenomenon and subsequently, the fouling problem may be defined as "*unsolved problem*" not as "*unresolved problem*" as mentioned in section (1).

## 16. Nomenclature

A	heat transfer surface area, $m^2$	$T_s$	surface temperature, $^{\circ}C$
$A_c$	heat transfer surface area for clean condition, $m^2$	t	time, s
$A_f$	heat transfer surface area for fouled condition, $m^2$	$t_c$	time constant ( $1/\beta$ ), s
$\Delta A$	percentage change A due to fouling, %	$t_d$	delay time, s
c	concentration, $kg/m^3$	$t^*$	required time to achieve asymptote, s
$c_b$	concentration at fluid bulk, $kg/m^3$	U	overall heat transfer coefficient. $W/m^2 \cdot K$
$c_s$	concentration at surface, $kg/m^3$	$\Delta U$	percentage reduction in U due to fouling, %
$c_p$	specific heat, $kJ/kg \cdot K$	$U_c$	overall heat transfer coefficient in clean condition. $W/m^2 \cdot K$
$d_i$	tube inner diameter, m	$U_f$	overall heat transfer coefficient in fouled condition. $W/m^2 \cdot K$
$d_o$	tube outer diameter, m	v	fluid flow velocity, m/s
$E_a$	activation energy, $kJ/kmol$	$x_f$	fouling layer thickness, m
f	friction factor	<b>Greek letters:</b>	
h	heat transfer coefficient of flowing fluid, $W/m^2 \cdot K$	$\beta$	f actor = $1/t_c$ , $s^{-1}$
$h_i$	heat transfer coefficient on the tube inside, $W/m^2 \cdot K$	$\lambda$	thermal conductivity, $W/m \cdot K$
$h_o$	heat transfer coefficient on the tube outside, $W/m^2 \cdot K$	$\lambda_f$	thermal conductivity of fouling layer, $W/m \cdot K$
k	transfer coefficient or constant	$\lambda_w$	thermal conductivity of wall material, $W/m \cdot K$
$k_1$	deposition coefficient (equation 10)	$\mu$	fluid viscosity, $N \cdot s/m^2$
$k_2$	removal coefficient (equation 11)	$\rho$	density, $kg/m^3$
$k_m$	mass transfer coefficient, m/s	$\rho_f$	density of fouling layer, $kg/m^3$
$m_f$	accumulated mass, $kg/m^2$	$\tau$	fluid shear stress, $N/m^2$
$\dot{m}_f$	rate of mass accumulation, $kg/m^2 \cdot s$	$\Phi_d$	deposition rate (thermal resistance unit), $m^2 \cdot K/W$
$\dot{m}_d$	deposition rate (mass unit), $kg/m^2 \cdot s$	$\Phi_r$	removal rate (thermal resistance unit), $m^2 \cdot K/W$
$\dot{m}_r$	removal rate (mass unit), $kg/m^2 \cdot s$	$\Psi$	deposit strength factor, $N/m^2$
$m_f^*$	asymptotic value of $m_f$ , $kg/m^2$		
Nu	Nusselt number		
	sticking probability		

P	pressure drop	$\Omega$	water characterization factor
$\Delta p$	Prandtl number	<b>Subscripts :</b>	
Pr	heat transfer rate, W	b	bulk
Q	heat flux, $W/m^2$	c	clean condition
q	percentage reduction in $q$ due to	d	deposition
$\Delta q$	fouling, %	f	fouled condition
	Reynolds number	i	inner
Re	fouling resistance, $m^2 \cdot K/W$	o	outer
$R_f$	asymptotic fouling resistance,	p	particle
$R_f^*$	$m^2 \cdot K/W$	r	removal
	universal gas constant, $kJ/kmol \cdot K$	s	surface
$R_g$	total thermal resistance to heat	w	wall
$R_t$	transfer		
	temperature, $^{\circ}C$		
T	fluid bulk temperature, $^{\circ}C$		
$T_b$	logarithmic mean temperature		
$\Delta T_m$	difference, $^{\circ}C$		

## 17. References

- [1] Bott, T. R., "Fouling of Heat Exchangers", Elsevier Science & Technology Books, 1995.
- [2] Kuppan, T., "Heat Exchanger Design Handbook", Marcel Dekker, Inc., New York, 2000.
- [3] Shah, R. K. and D. P. Sekulić, "Fundamentals of Heat Exchanger Design", John Wiley & Sons, Inc., 2003.
- [4] Pritchard, A. M., "The Economics of Fouling", in Fouling Science and Technology, (L. F. Melo et al, eds.), Kluwer Academic Publishers, Netherlands, pp 31-45, 1988.
- [5] Tay S. N. and C. Yang, "Assessment of The Hydro-Ball Condenser Tube Cleaning System", Hydro-Ball Technics Sea Pte. Ltd, Singapore, 2006.
- [6] Puckorius, P. R., "Controlling Deposits in Cooling Water Systems", *Mater. Protect. Perform.*, November, pp19-22, 1972.
- [7] Chenoweth, J. M., "Final Report of the HTRI/TEMA Joint Committee to Review the Fouling Section of the TEMA Standards", Heat Transfer Research, Inc., Alhambra, Calif., 1988.
- [8] Mukherjee, R., "Conquer heat exchanger fouling", *Hydrocarbon Processing*, January, pp 121-127, 1996.
- [9] Bott, T. R., "Fouling Notebook", Institution of Chemical Engineers, Rugby, UK, 1990.
- [10] Knudsen, J. G., "Apparatus and Techniques for Measurement of Fouling of Heat Transfer Surface", in *Fouling of Heat Transfer Equipment* (E. F. C. Somerscales and J. G. Knudson, eds.), Proceedings of the International Conference on the Fouling of Heat Transfer Equipment, Hemisphere, Washington, D.C., pp. 57-81, 1981.
- [11] Zelter, N., Roe, F. L., and Characklis, W. G., "Monitoring of Fouling Deposits in Heat Transfer Tubes: Case Studies", in *Industrial Heat Exchangers Conference Proceedings* (A. J. Hayes, W. W. Liang, S. L. Richlen, and E. S. Tabb, eds.), American Society for Metals, Metals Park, Ohio, pp 201-208, 1985.

- [12] TEMA, "Standard of the Tubular Exchanger Manufacturers Association", 8th ed., Tubular Exchanger Manufacturers Association, New York, 1999.
- [13] Zubair, S. M., and R. K. Shah, "Fouling in Plate-and-Frame Heat Exchangers and Cleaning Strategies", in Compact Heat Exchangers and Enhancement Technology for the Process Industries, (R. K. Shah, A. Deakin, H. Honda and T. M. Rudy, eds.), Begell House, New York, pp. 553-565, 2001.
- [14] Kern, D.Q. and Seaton, R.E., "A Theoretical Analysis of Thermal Surface Fouling", Brit. Chem. Eng. 14, No. 5, 258, 1959.
- [15] Watkinson, A.p., "Process Heat Transfer: Some Practical Problems", Can. J. Chem. Eng., 58, pp 553-559, 1980.
- [16] Taborek, J., Aoki, T., Ritter, R.B., Palen, J.W. and Knudsen, J.G., "Predictive Methods for Fouling Behavior". Chem. Eng. Prog. 68, No. 7, 69 - 78, 1972.
- [17] Knudsen, J.G. "Fouling of Heat Transfer Surface: An Overview", in Power condenser - Heat transfer technology, (P.J. Marto and R.H . Nunn, eds.), pp 375-424, Hemisphere, London, 1981.
- [18] Stegelman, A. F., and Renffltlen, R., "On-Line Mechanical Cleaning of Heat Exchangers", *Hydrocarbon Processing*, 95-97, 1983.
- [19] Crittenden, B.D., Kolaczkowski, S.T. and Takemoto, T., "Use of in Tube Inserts to Reduce Fouling from Crude Oils". AIChE Symp. Series, 295, 89, 300- 307, Atlanta, 1993.
- [20] Hughes, D.T., Bott, T.R. and Pratt, D.C.F., "Plastic Tube Heat Transfer Surfaces in Falling Film Evaporators". Proc. Second UK Nat. Conf. on Heat Transfer, Vol. 2, 1101 - 1113, 1988.
- [21] Epstein, N., "On Minimizing Fouling of Heat Transfer Surfaces", in *Low Reynolds Number Flow Heat Exchangers* (S. Kakac, R. K. Shah, and A. E. Bergles, eds.), Hemisphere, Washington, D.C., pp. 973-979, 1982.
- [22] Kim, W.T., Y. I. Cho, and C. Bai, "Effect of Electronic Anti-Fouling Treatment on Fouling Mitigation with Circulating Cooling Tower Water", Int. Comm. Heat and Mass Transfer, vol. 28, No.5, pp. 671-680, 2001.
- [23] Knudsen, J. G., "Fouling in Heat Exchangers", in Heat Exchanger Design Handbook, G. F.Hewitt, ed., Begell House, New York, Sec. 3.17,1998.
- [24] Epstien, N., "Particulate Fouling of Heat Transfer Surfaces: Mechanisms and Models", in Fouling Science and Technology, (L.F. Melo et al, eds.), 143-164, Kluwer Academic publishers, Netherlands, 1988.
- [25] Fryer, P. J., "Modelling Heat Exchanger Fouling", Ph.D Thesis, University of Cambridge, UK., 1986.
- [26] Awad, M. M., "Effect of Flow Oscillation on Surface Fouling", Mansoura Engineering Journal (MEJ), Vol.28, No2, pp M47-M56, June 2003.
- [27] Awad, M. M., I. Fathy and H. E. Gad "Effect of Surface Temperature on the Fouling of Heat Transfer Surfaces", 11<sup>th</sup> International Water Technology Conference, Sharm El Sheikh, Egypt, March, 2007.
- [28] Awad, M. M., S. M. Abd El-Samad, H.E. Gad and F.I. Asfour "Effect of Flow Velocity on the Surface Fouling", Mansoura Engineering Journal (MEJ), Vol.32, No1, pp M27-M37, March, 2007.

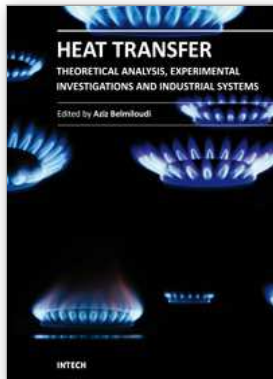

## Heat Transfer - Theoretical Analysis, Experimental Investigations and Industrial Systems

Edited by Prof. Aziz Belmiloudi

ISBN 978-953-307-226-5

Hard cover, 654 pages

**Publisher** InTech

**Published online** 28, January, 2011

**Published in print edition** January, 2011

Over the past few decades there has been a prolific increase in research and development in area of heat transfer, heat exchangers and their associated technologies. This book is a collection of current research in the above mentioned areas and discusses experimental, theoretical and calculation approaches and industrial utilizations with modern ideas and methods to study heat transfer for single and multiphase systems. The topics considered include various basic concepts of heat transfer, the fundamental modes of heat transfer (namely conduction, convection and radiation), thermophysical properties, condensation, boiling, freezing, innovative experiments, measurement analysis, theoretical models and simulations, with many real-world problems and important modern applications. The book is divided in four sections : "Heat Transfer in Micro Systems", "Boiling, Freezing and Condensation Heat Transfer", "Heat Transfer and its Assessment", "Heat Transfer Calculations", and each section discusses a wide variety of techniques, methods and applications in accordance with the subjects. The combination of theoretical and experimental investigations with many important practical applications of current interest will make this book of interest to researchers, scientists, engineers and graduate students, who make use of experimental and theoretical investigations, assessment and enhancement techniques in this multidisciplinary field as well as to researchers in mathematical modelling, computer simulations and information sciences, who make use of experimental and theoretical investigations as a means of critical assessment of models and results derived from advanced numerical simulations and improvement of the developed models and numerical methods.

### How to reference

In order to correctly reference this scholarly work, feel free to copy and paste the following:

Mostafa M. Awad (2011). Fouling of Heat Transfer Surfaces, Heat Transfer - Theoretical Analysis, Experimental Investigations and Industrial Systems, Prof. Aziz Belmiloudi (Ed.), ISBN: 978-953-307-226-5, InTech, Available from: <http://www.intechopen.com/books/heat-transfer-theoretical-analysis-experimental-investigations-and-industrial-systems/fouling-of-heat-transfer-surfaces>

**INTECH**  
open science | open minds

### InTech Europe

University Campus STeP Ri  
Slavka Krautzeka 83/A  
51000 Rijeka, Croatia

### InTech China

Unit 405, Office Block, Hotel Equatorial Shanghai  
No.65, Yan An Road (West), Shanghai, 200040, China  
中国上海市延安西路65号上海国际贵都大饭店办公楼405单元

Phone: +385 (51) 770 447  
Fax: +385 (51) 686 166  
[www.intechopen.com](http://www.intechopen.com)

Phone: +86-21-62489820  
Fax: +86-21-62489821



© 2011 The Author(s). Licensee IntechOpen. This chapter is distributed under the terms of the [Creative Commons Attribution-NonCommercial-ShareAlike-3.0 License](#), which permits use, distribution and reproduction for non-commercial purposes, provided the original is properly cited and derivative works building on this content are distributed under the same license.