

# Motion Control of Robots Based on Sensings of Human Forces and Movements

Tao Liu, Chunguang Li, Kyoko Shibata and Yoshio Inoue  
*Kochi University of Technology*  
*Japan*

## 1. Introduction

### 1.1 Requirement for arm therapy and clinical background

The percentage of aged persons is continuously increasing in many countries, which is becoming a social problem demanding concern from different fields including social science, medical science and engineering. This trend is particularly rigorous in Japan where the aged (over 65 years old) accounted for 20.8% of the total population up to 2006 (Statistics Bureau, 2007). In the elderly, the prevalence of physical deterioration is sharply high, and their physical deterioration generally leads to degeneration of some motor functions. Besides, Hemiplegic limb impairment after a stroke which is a common disease among the aged, is becoming a global issue. Both motor function deterioration and disability have an indirect influence on brain degeneration. Thereby, strength enhancement and function recovery are necessary in the aging society. Moreover, physical therapy resources are quite limited, and the rehabilitation therapy places a large economic burden on patients. Under these conditions, considerable interest has been stimulated in the development of upper limb rehabilitation robots which can act as a therapeutic aid for therapists in rehabilitation training.

### 1.2 Related rehabilitation robots and problems

Among the numerous robots designed to deliver arm therapy, MIT-MANUS (Hogan & Krebs, 2004; Krebs et al., 2000), ARM-GUIDE (Reinkensmeyer et al., 1999 & 2000), and MIME (Burgar et al., 2000; Lum et al., 2002 & 2004) are three representative devices that have been tested extensively on hemiplegic patients. MIT-MANUS can support patients in executing reaching movements in a horizontal plane; ARM-GUIDE and MIME can give training in a three-dimensional workspace. ARM-GUIDE allows the subject to exercise against the gravity and can be used as a diagnostic tool and a treatment tool for addressing the arm impairment in hemiparetics. With MIME the limb's position can be inferred from the robot's position based on measurements of the interaction forces. It was verified that the subjects who received MIME therapy had statistically higher gains in arm motor function by having the both upper limbs execute movements that mirror one another. ARMin (Nef et al., 2007) is another representative robotic device which can deliver patient-cooperative arm therapy. However, these robotic arms are heavy in weight and must be fixed on walls and

poles, so the motion space is limited and patients are easily to feel excess fatigue. Otherwise, these robots are too complex to set up by patients themselves, thus, they are not suitable for carrying out rehabilitation training at home (Zheng et al., 2006).

A home environment makes it possible to increase duration that patients spend in rehabilitation activities, thus it can ensure a high level of intervention with adequate intensity and frequency that can improve the motor recovery (van Exel et al., 2005). In addition, the home-based rehabilitation can reduce economic burden to a certain extent. Therefore, the development of wearable robots which can be easily used in patients' home is a new tendency recently. For example, a new human motion tracking system using two body-mounted inertial sensors to measure upper limb motion (Zhou et al., 2008) was developed for home-based therapy. In this system, motion tracking is implemented with a pure position control and a visual feedback but without a sensible force feedback, thus operators can not be well informed about the exact status of the impaired limb. Since interaction conditions between the robot and the patient can vary considerably depending on the patient's kinetic capabilities and unpredictable reactions to therapeutic stimuli (Reinkensmeyer et al., 2000), the security and reliability of the system can not be ensured.

A force assistant master-slave tele-rehabilitation robotic system (Li & Song, 2008), which realizes impedance transfer by means of force transducers, enables therapists to experience the interaction force between the robot and the impaired limb, and thus increases the adaptability of the system. The systems introduced by Song & Guo (2006) and Peng et al. (2005) are also capable of force feedback. However, the force feedback control in these robotic systems is realized with force sensors, which has the drawbacks of introducing control complexity (both the force control and position control are needed), high system cost, and mounting difficulty. Otherwise, the operators of the above robots are the therapists rather than the patients themselves. That is, the patient is trained passively. Even though the therapist can optimize the therapy scheme according to the feedback force, but the degree of comfort of the patients can not be sensed. This is unfavourable to acquire good recovery effect.

RoboWear (Jeong et al., 2001), a wearable robotic arm with high force-reflection capability, can be operated by the patient himself/herself, but it needs two pressure sensors to realize force-reflection. The system introduced by Gang & Shuxiang (2006) realized self-assisted rehabilitation, but the training program is based on a virtual reality environment and the system is only suitable for training mildly affected limbs.

### 1.3 Research aims

Working from the above realization, a master-slave control scheme utilizing the healthy limbs of hemiplegic patients is presented for home-based wearable rehabilitation robots. With this control system, the patient can directly feel the interaction force between the robot and the impaired limb without force sensors, and can make a timely and proper adjustment to input force of the healthy limb according to the reflected force as well as the degree of comfort of the impaired limb. Besides, the movement trajectory is controlled by the patient himself/herself, this can increase the patient's motivation and activity, and can further enhance the recover progress (Hogan et al., 2006; Jack et al., 2001). Moreover, the energy generated by the master site is transmitted to the slave site, which can realize a kind of energy recycling.

## 2. Methods and materials

### 2.1 Theoretical analysis: force sensing

The master-slave control system contains two identical DC motors with the master motor being operated by the healthy limb and the slave one behaving in the same manner as the master. The master motor as a generator powers the slave motor which works as an actuator, to rotate and support the impaired limb in rehabilitation activities. The equivalent closed-loop circuit of the master-slave control system is given in Fig. 1, in which  $M_1$  and  $M_2$  represent the master motor and slave motor respectively.

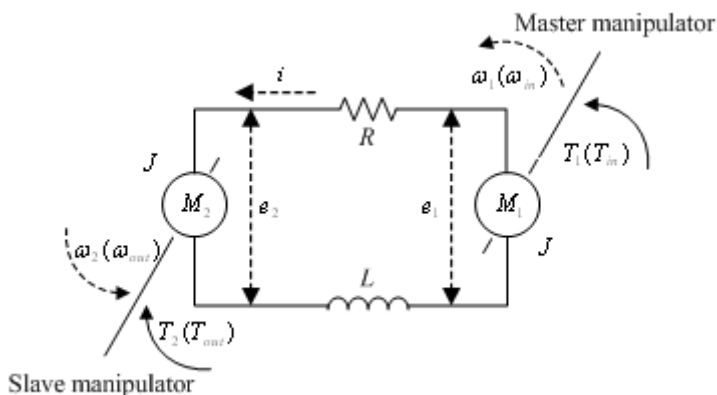

Fig. 1. Equivalent circuit of the master-slave control system

Based on the dynamics mechanism, the motion equation is written as

$$\begin{cases} T_1 = T_{M1} + T_0 \\ T_{M2} = T_2 + T_0 \\ T_{M1} = T_{M2} = C_T i \end{cases} \tag{1}$$

where  $T_1$  and  $T_2$  are the mechanical torques in the master and slave motor shafts, also represent the input torque obtained from the operator and the output torque used to drive workload ( $T_{in}$  and  $T_{out}$ );  $T_{M1}$  and  $T_{M2}$  are the electromagnetic torques, which equals to the multiplication of the motor torque constant  $C_T$  and the closed-loop current  $i$ , and has the same magnitude;  $T_0$  is the unload torque caused by unload losses including mechanical energy loss, magnetic core loss, and added loss. According to (1), the relationship between the input and output torque can be re-expressed as

$$T_1 = T_2 + 2T_0 \tag{2}$$

This suggests that in order to drive the workload exerting the torque  $T_2$  on the slave motor shaft, the input torque provided for the master motor should be no less than the summation of  $T_2$  and  $2T_0$ . If the input torque is less than this summation, the operator can feel the

difficulty and increase input force accordingly. This means that the system is capable of realizing force sensing without a force sensor. Thus, both the hardware and software design can be simplified to a great extent. In fact, since the two motors possess the same current, the master electromagnetic torque equals to the slave electromagnetic torque and varies following load variation. Then the input force can be adjusted according to the variation of the master electromagnetic torque. As well, unload torque,  $T_0$ , which mainly depends on the rotational speed, also has reflection in the master site. That is, the operator can regulate the input force according to the variation of workload and the perception of velocity. The force and velocity sensing characteristic enables the operator to control the movement trajectory of the two limbs by himself/herself without a trajectory definition program, so this simplifies the software design greatly.

## 2.2 Theoretical analysis: energy recycling

Based on the electrical mechanism, the dynamic voltage balance equation of the master-slave circuit can be written as

$$Ri + L \frac{di}{dt} = e_1 - e_2 = C_T \omega_1 - C_T \omega_2 \quad (3)$$

where  $R$  and  $L$  denote the armature resistance summation and inductance summation, respectively;  $\omega_1$  and  $\omega_2$  are the rotor speeds of the master and slave motors, also are the input and output speeds ( $\omega_{in}$  and  $\omega_{out}$ ) here; and  $e_1$  and  $e_2$  are the armature voltages, which depend on the motor torque constant and rotor speed.  $e_2$  is called as reverse EMF (electromotive force) since it has an opposite-directional current. As can be seen from (3), the energy generated by the master motor is transmitted to the slave motor except the energy loss in the resistance and inductance, thus the system can realize a kind of energy recycling. Furthermore, the smaller the current, the smaller the energy loss in the closed-loop (energy recycling) circuit will be, leading to  $\omega_2$  with a nearer approach to  $\omega_1$ . Therefore, a small current is helpful for achieving an accurate motion tracking.

## 2.3 Master-slave control system design

During rehabilitation operation, in order to drive the impaired limb to imitate the motion of healthy limb correctly, a high motion tracking performance is necessary. As the analysis above, a small closed-loop current is preferable. However, it is difficult to achieve a small current to drive the impaired limb (a relatively large workload) with a DC motor directly. Otherwise, it is almost impossible to find motors with sufficient torques to support the impaired limb directly. Even if it is possible, the hemiplegic patients will be unable to wear the rehabilitation robot because high-power motors tend to be heavy. Thus, the gearbox mechanism is adopted here to reduce the closed-loop current for enhancing the motion tracking performance, and to increase the driving power of the system with small DC motors. On the other hand, even though the inside energy loss can be reduced by the gearbox mechanism, the yet existent energy loss makes it impossible to realize an acceptable motion tracking performance. Hence, the appropriate amount of energy is compensated for the closed-loop circuit to offset the inside energy loss, further achieving a high motion tracking property. The corresponding introduction is given below:

1) Gearbox mechanism: In order to acquire a symmetric mechanism, two identical gearboxes are employed in the master and slave sites. An equivalent circuit is shown in Fig. 2. The gear transmission relationship can be expressed as

$$\begin{cases} \omega_1 = N\omega_{in}, \omega_2 = N\omega_{out} \\ T_{in} = NT_1, T_{out} = NT_2 \end{cases} \quad (4)$$

where  $N$  is the gear ratio of the two gearboxes;  $\omega_1, \omega_2$  and  $T_1, T_2$  are still used to indicate the rotor speeds and the mechanical torques in the two motor shafts;  $\omega_{in}$  and  $\omega_{out}$  stand for the input and output speeds;  $T_{in}$  and  $T_{out}$  represent the input and output (load) torques of the system. The gear ratio can be selected by dividing the motor rated torque into the load torque, which can be estimated with the radius of the force arm in the slave site and the mass of the unhealthy limb.

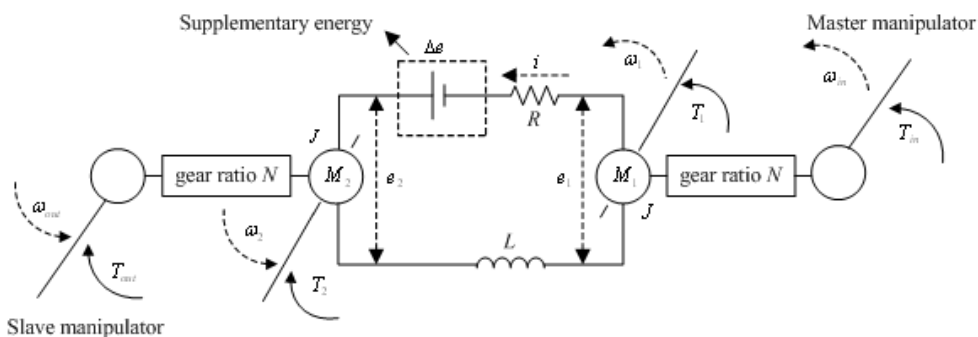

Fig. 2. Equivalent circuit of the system with gearbox mechanism

As can be seen from (4), the torques in motor shafts are minified  $N$  times compared to the input/output torques, and the rotor speeds are magnified  $N$  times compared to the input/output speeds. This leads the armature voltage generated by the master motor to be  $N$ -times magnified, and the current to be  $N$ -times minified (refer to (1) and (3)), while the electric power to be kept nearly constant. Thus, the energy loss in the energy transfer circuit (closed-loop circuit) can be reduced. This can increase the energy recycling efficiency in the electronic circuit, and is advantageous to realize motion tracking. However, the unload loss will be increased slightly due to the magnified speeds in motor shafts. Additionally, there is energy loss in the gearboxes. That is, in order to enhance the energy recycling efficiency in the closed-loop circuit, the operator should deliver a larger input power to drive the system. Besides, the gearbox mechanism can also increase the load-bearing capability, making the system have enough driving power to motivate the impaired limb without high-power motors, and being advantageous to reduce the weight as well as the volume of the system. By combining (1) and (4), the relationship of the input electric power and output torque can be re-expressed as

$$T_{in} = T_{out} + 2NT_0 \quad (5)$$

The difference between the input and output torques is magnified  $N$  times, thus a larger input torque is required for driving the same load. But this does not impact the force sensing capability towards load variation so long as  $2NT_0$  is not much larger than  $T_{out}$ . However, the variation of the unload torque, which relies on rotational speed variation, has a greater reflection in the master site. Based on the analysis above, we can conclude that the gearboxes with appropriate gear ratio have small impact on force sensing ability, but have a relatively large influence on the motion sensing ability. The gearboxes should be decided based on test experiments.

2) Energy supplement: The gearboxes can enhance energy recycling efficiency, whereas the reduced energy loss makes it impossible to realize an acceptable motion tracking performance yet. Therefore, the appropriate amount of energy is compensated for the closed-loop circuit to offset the inside energy loss, further achieving a high motion tracking property. The supplementary energy is added to the system as shown in the dashed line frame of the Fig. 2. The supplementary energy is regulated by adjusting the duty cycle of a pulse-width modulated (PWM) signal that is fed to an H-bridge driver and enables the driver to provide moderate energy for the closed-loop circuit. The compensated voltage,  $e_{sup}$ , can be calculated as

$$e_{sup} = \alpha U_s \quad (6)$$

where  $U_s$  is the supply voltage of the H-bridge driver, and  $\alpha$  is the duty cycle of the PWM signal.

During operation, it is hoped that the input and output sites have the same movement behaviour. Here, based on the position difference and speed difference between the two motors, a motion tracking control (position-speed control) is carried out to calculate the required supplementary energy for the circuit. This controller can regulate the direction of compensated energy in accordance with the amplitude and direction of the rotational speeds, thus can assure the two motors to possess the same motion trajectory no matter in which side the master motor is located.

The power transmission flowchart of the master-slave control system is shown in Fig. 3, in which master/gear unit and slave/gear unit represent the side exerted with an active force and the side attached with a resistant force,  $P_{in}$  and  $P_{out}$  denote the input power and output power of the system;  $P_{1\_in}$ ,  $P_{1\_M}$ , and  $P_{1\_out}$  represent the input mechanical power, the electromagnetic power, and the output electric power of the master motor, respectively;  $P_{2\_in}$ ,  $P_{2\_M}$ , and  $P_{2\_out}$  are the input electric power, the electromagnetic power, and the output mechanical power of the slave motor, respectively; and  $p_{sup}$  is the compensated energy power for the inside closed-loop circuit. The various energy losses in the system are listed in Table 1. Mechanical loss, magnetic core loss and excitation loss are mainly caused by the mechanical friction and alternative magnetic field towards armature core, and they are called as unload loss in general and primarily related to the rotational speed. Resistance loss and contact loss called as load loss are losses caused by the current in the armature circuit, and they change mainly following the current variation.

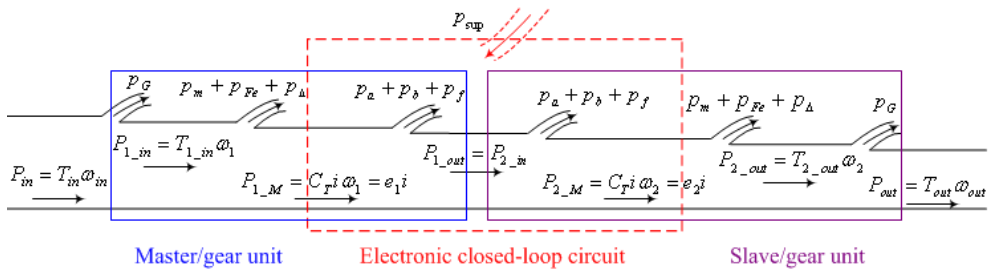

Fig. 3. The power transmission flowchart of the master-slave system

gear loss	mechanical loss	core loss	added loss	resistance loss	contact loss	excitation loss
$p_G$	$p_m$	$p_{Fe}$	$p_\Delta$	$p_a$	$p_b$	$p_f$

Table 1. Various losses in the control system

As shown in Fig. 3, the relationship between the input power from the operator and the output electric power of the master motor is given by:

$$P_{1\_out} = P_{in} - p_G - (p_m + p_{Fe} + p_\Delta) - (p_a + p_b + p_f) \tag{7}$$

In the slave site, there is a reverse energy transmission flow, with the relationship between the input and output power expressed as

$$P_{out} = P_{1\_out} - (p_a + p_b + p_f) - (p_m + p_{Fe} + p_\Delta) - p_G \tag{8}$$

The supplementary energy,  $p_{sup}$ , is used to offset energy losses  $p_a$ ,  $p_b$ , and  $p_f$  in the two motors. When the system achieves motion tracking accurately,  $\omega_{out}$  equals to  $\omega_{in}$ . According to (4), we can obtain

$$P_{1\_M} = P_{2\_M} \tag{9}$$

Thus the supplementary energy can be expressed as

$$p_{sup} = 2(p_a + p_b + p_f) \tag{10}$$

where  $p_a$  is the main part of the energy losses in the closed-loop circuit. When the energy loss in the closed-loop circuit is fully compensated, overall system efficiency depends upon the gearbox efficiency and the energy losses including  $p_m$ ,  $p_{Fe}$ , and  $p_\Delta$ .

### 2.4 Working modes

The force sensing capability and the symmetric mechanism make the system has no limitation in the orientation of the master and slave manipulators. That is, each side can act as the master manipulator; accordingly, the other site will act as the slave manipulator. This suggests that the system can work well no matter in which side the limb is unhealthy. With this master-slave control system, a patient's impaired limb can be exercised in different modes by coordinating the two limbs. The different training modes are explained as follows:

1) Passive mode: one motor is operated by the healthy limb and deemed as the master motor to drive the other motor which is connected with the impaired limb and deemed as the slave motor. When the healthy limb rotates the master motor, the slave motor imitates the trajectory of the master and supports the impaired limb to exercise. The movement trajectory and velocity are controlled by the healthy limb, and are subject to the acceptable motor capacity of the impaired limb. During the operation, the patient feels resistant force from the impaired limb, and adjusts input force of the healthy limb properly to achieve an expected movement trajectory and velocity within the range of motor capacity of the impaired limb. This control mode can be adopted when the motor capacity of the unhealthy limb is extremely weak.

2) Active-assistive mode: the impaired limb tries to rotate the slave motor; on the other side, the healthy limb feels the reflected force (amplitude and direction) in the master site and provides an auxiliary force to help the impaired limb complete the movement. In this mode, both the motors work in the generating state. The electric power generated by the master as auxiliary input electric energy is provided for the slave motor, to reduce the input force requirement of the affected arm, and to accomplish the movement even if the motor capacity of the affected arm is not strong enough. That is, when the impaired limb has insufficient ability to move, the auxiliary force can offer positive power to assist the impaired limb to carry on movement with an expected trajectory and speed. The movement trajectory and speed is dependent on the impaired limb's motor capacity as well as the auxiliary force from the healthy limb. This control mode can be used when the impaired limb has a mild motor capacity.

3) Active-resistive mode: the impaired limb tries to rotate the slave motor, and the healthy limb provides a reverse force to resist this movement. In this mode, the two motors still work in the generating state, but the master motor provides negative electric power for the slave to resist movement of the affected limb. Similarly, the movement trajectory and speed relies on the forces from the unhealthy and healthy limbs. This control mode can be used when the unhealthy limb has a certain recover in motor function and should be trained with an opposite acting force.

With the above working modes, the valid limb can provide a varying force to the movement of the affected one, ranging from full assistance, where the affected limb only can behave passively, to resistance, if the impaired limb has sufficient voluntary control ability.

### 3. Experimental study

#### 3.1 Experimental platform

In order to verify the viability of the above approach, a preliminary test platform, as shown in Fig. 4, was built for experiments. Fig. 5 is the corresponding schematic diagram. The platform is composed of two identical motors (A-max 32 motor, combined with Planetary Gearhead GP 32 A, N=4.8 and Encoder HEDL 5540, maxon co. Switzerland), an H-bridge driver (LMD18200, National Semiconductor co. America), two torque transducers (TP-20KCE, Kyowa co. Japan), a torque signal amplifier, and a dSPACE control platform (CLP1104, dSPACE Inc, Germany). Here, the torque transducers and the torque signal amplifier are adopted to measure the input and output torques for verifying the force sensing ability of the system in our test experiments.



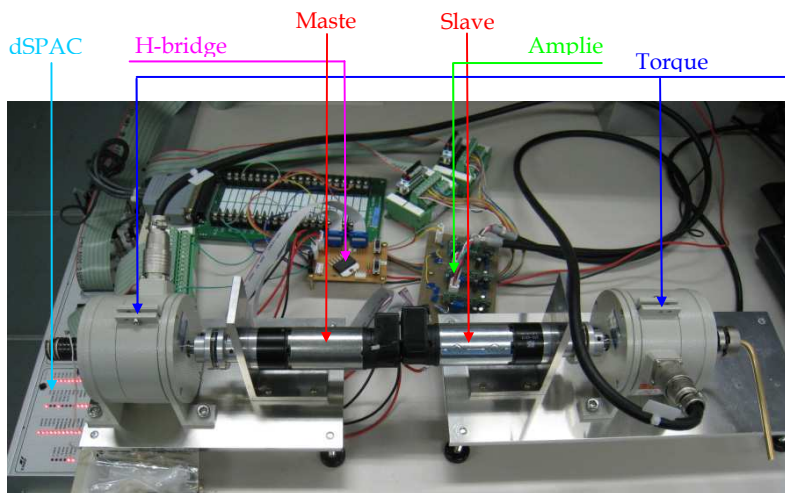

Fig. 4. The experimental platform of the master-slave control system

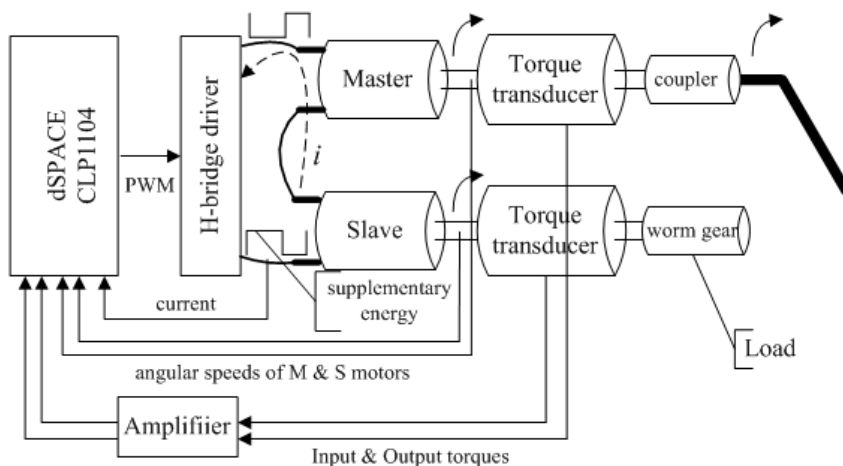

Fig. 5. Schematic diagram of the master-slave motor control system

**3.2 Control flow**

In the experiment system, the operator used the left hand to exert a force in the slave site and sensed this force reflected in the master site, then used the right hand to provide a moderate force (a driving force to overcome the resistance of the left hand or an auxiliary force to assist the left hand) to rotate the left hand. The speed and position information was detected with the incremental encoders, and the torque information was detected with the torque transducers. The CLP1104 collected the speed and position information through the incremental encoder interface, and worked out the control quantity  $\alpha$  of the PWM signal

with the motion control strategy, then through the PWM generation module in the slave DSP of the CLP1104 to offer PWM signal for the H-bridge driver, enabling the driver to supply the compensatory energy for the master-slave motor circuit. Simultaneously, the CLP1104 collected the datas of the current in the electronic closed-loop circuit and the torques in two sites through the AD module in the slave DSP system.

In each control period (one millisecond), the regulated duty cycle of the PWM signal, the rotational speed, and the corresponding current were used to calculate the energy loss in the electronic circuit, the supplementary energy provided by the H-bridge driver, and the electromagnetic power of the slave motor (equals to master electromagnetic power in balance state). The corresponding calculation formula is

$$\begin{cases} p_{\text{sup}} = \alpha U_s i \\ p_a = i^2 R \\ P_{2\_M} = e_2 i = C_T \omega_2 i \end{cases} \quad (11)$$

To ensure the global stability, a PID (proportional-integral-differential) control module was built in the DSP system for the position-speed feedback (motion tracking) control. Since the input speed (controlled by the operator) is not a constant, if the differential operation is applied to the speed difference between the input and output sites, the variation of the input speed may lead to overshoot and fluctuation of the whole system. Therefore, the differential operation is applied only to the output speed of the slave motor.

## 4. Evaluation experiment

### 4.1 Force sensing test

In this experiment, a variable resistant force was imposed on the slave motor site with the left hand; and in the master site, the operator felt this force and used the right hand to provide a reaction force to overcome the resistance and to rotate the left hand. The corresponding results are given in Fig. 7.

The curves of the input torque and the load torque have the same trend (see Fig. 7 (a)), which verifies that the system has force sensing capability. The operator sensed the load torque variation reflected in the master site, and adjusted the input force accordingly to maintain the speed with a certain variation regulation. The large difference between the input and output torque was caused by the unload torque and the torque amplification function of the gearboxes (refer to (5)). And the difference was almost constant when there was a small variation in the rotational speeds, because the unload torque mainly varies following the changes of the speeds. When the input force in the master site is considered as the driving force and the force attached in the slave site is deemed as resistance, we can say that the system worked in the passive mode; while when the force in the slave site is considered as the input force and the force added in the master site is deemed as the resistant force, we can say that the system worked in the active-resistance mode.

From Fig. 7 (b) and (c), we noted that the system possessed a good motion tracking performance. The maximum steady-state errors were 2.2950 rad/s in speeds and 0.0538 rad in position for the two DC motors. While the maximum steady-state errors in the input and output sides were minified 4.8-times (gear ratio) by the gearboxes. That is, the maximum steady-state errors of the system were 0.4781 rad/s in speeds and 0.0112 rad in position. Figure 7 (d) manifests that the supplementary energy was approximately coincident with

the resistance loss. However, the former was slightly larger than the latter because the contact loss and excitation loss also occurred in the energy recycling circuit (refer to (10)). We noted that the energy loss was much larger than the electromagnetic power. This situation will be changed when we use gearboxes with a larger gear ratio which can further reduce the closed-loop current and increase the speeds of the motors.

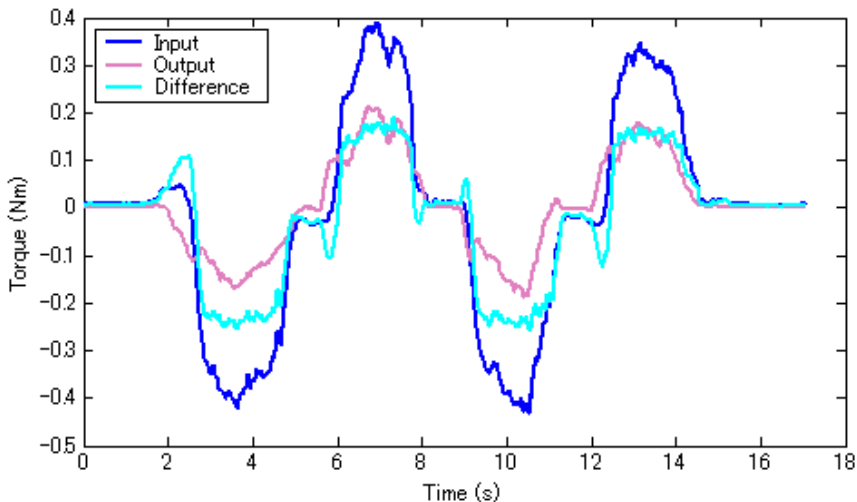

(a) A representative results of the input torque, the output torque and the difference between the input and output torques

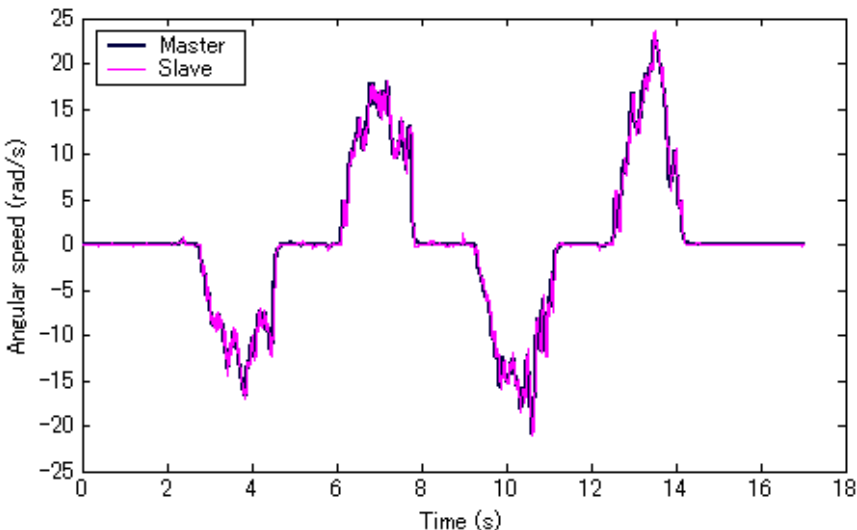

(b) Speed tracking curves of the motors

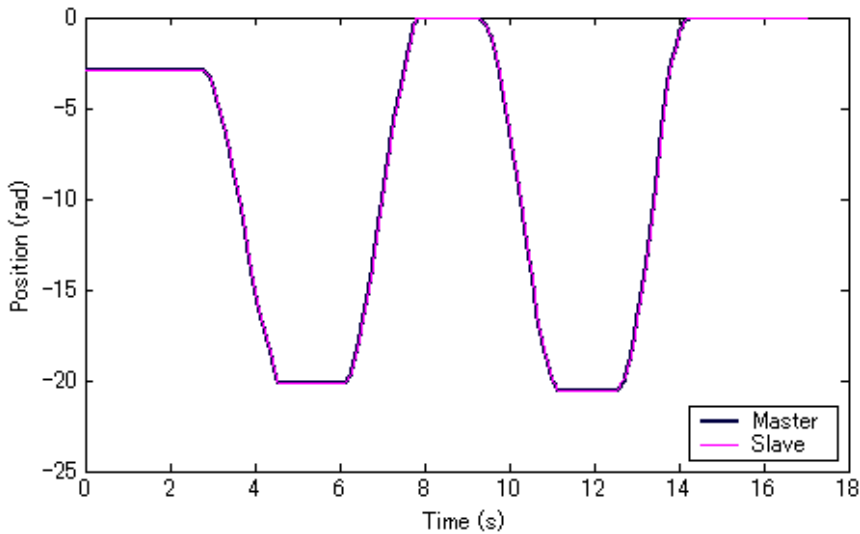

(c) Position tracking curves of the motors

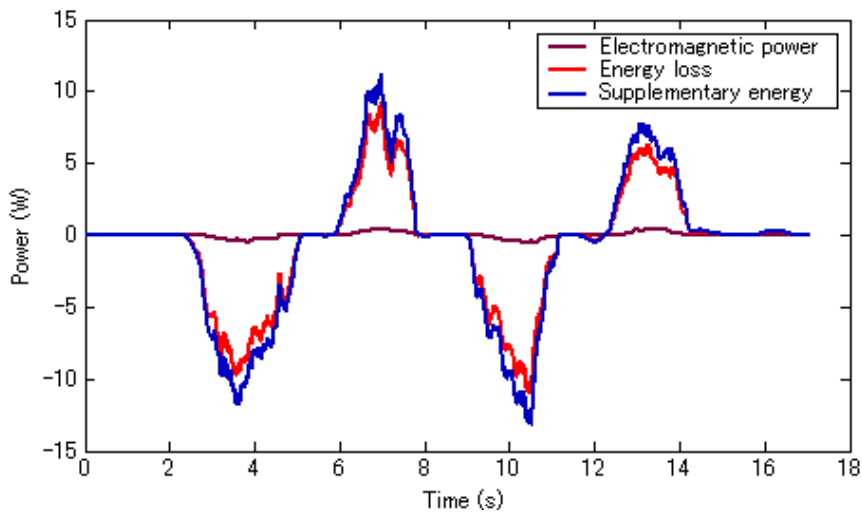

(d) The relation curve of resistance loss, compensated energy and electromagnetic power  
Fig. 6. The results of the force sensing test

#### 4.2 Active-assistance exercise test

In this experiment, the left hand exerted a force in the slave motor site; and in the master site, the right hand sensed this force, and provided an auxiliary force to assist the left hand to move. The corresponding results are given in Fig. 8.

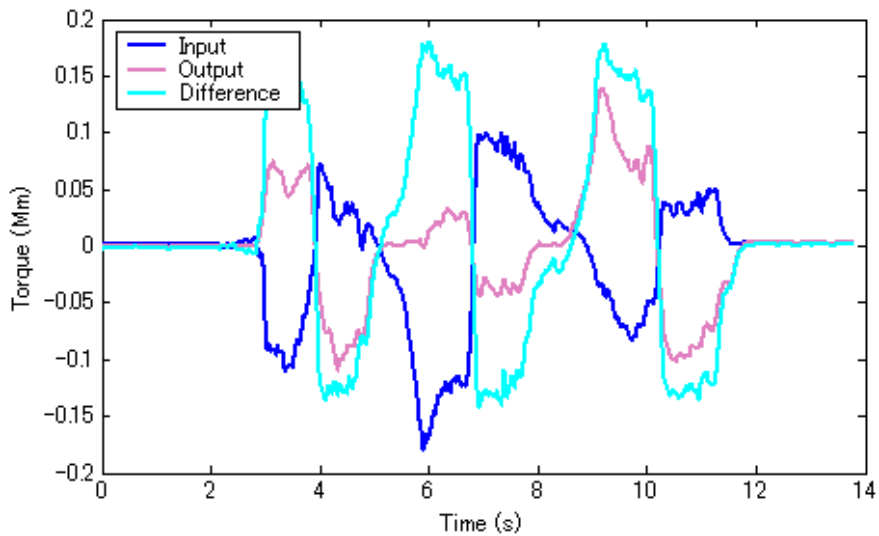

(a) A representative results of the input torque, the output torque and the difference between the input and output torques

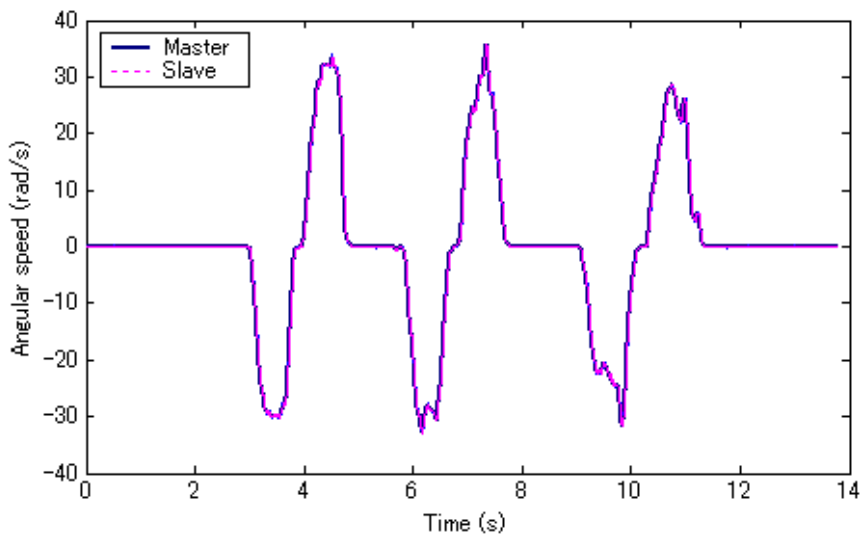

(b) Speed tracking curves of the motors

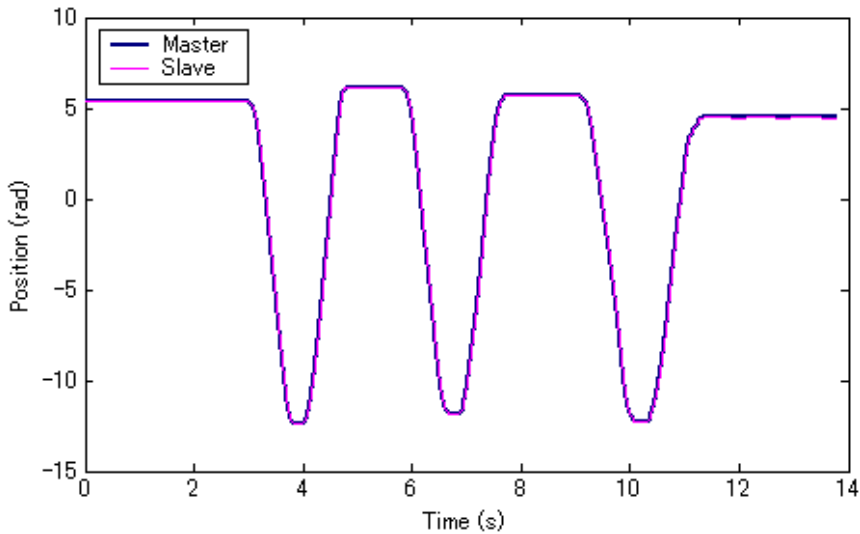

(c) Position tracking curves of the motors

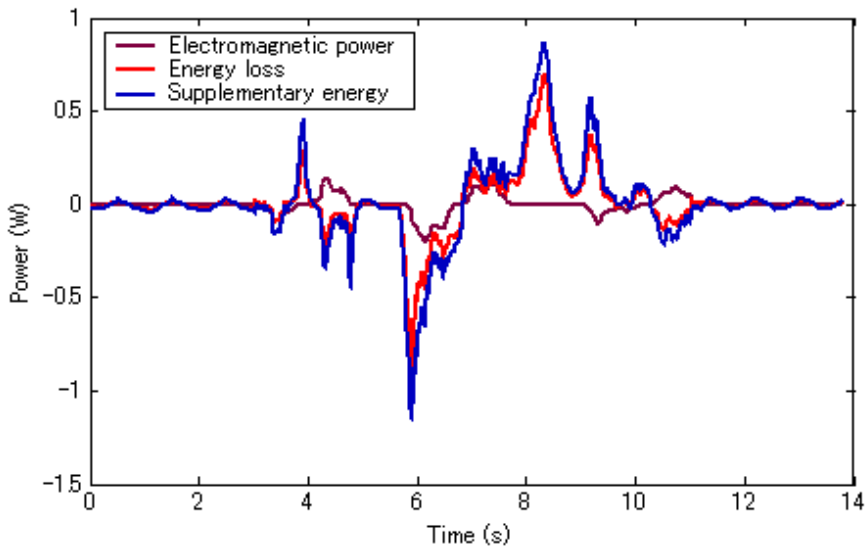

(d) The relation curve of resistance loss, compensated energy and electromagnetic power Fig. 7. The results of the active-assistive working mode test

It can be seen from Fig. 8 (a), in order to keep the speed with almost the same variation trend, the input force provided for the master part was increased or decreased following the reduction or increase of the force exerted in the slave part (In order to test force sensing capability in the precious experiment, the forces in both sites with the opposite direction

were defined to have the same sign symbol. Thus the assistive force here possessed an opposite sign symbol compared to the active force in the slave site). However, the difference between the two forces, which represents the summation of the two forces actually, had the same variation trend and was coincident with the speed variation. This verifies that the operator can regulate the input force moderately based on expected rotational speed and the reflected force of the slave site. Therefore, the system is capable of carrying out the active-assistive training. In this working mode, the system also possessed a good motion tracking performance. The maximum steady-state errors of the system were 0.2657 rad/s in speeds and 0.0067 rad in position. Meanwhile, figure 7 (d) manifests that the supplementary energy was used to offset the energy loss in the electronic circuit, in which the resistance loss accounts for the mainly part. As well, it is obvious that the supplementary energy had no relation to the electromagnetic power. This verified that except the portion used to compensate the resistance loss, the supplementary energy was used to compensate the contact loss and excitation loss in the circuit, rather than to provide power for the two motors.

## 5. Discussion

The experimental results verify the theory introduced above, and confirm the feasibility of the proposed control method. However, there are some drawbacks as follows:

- 1) Even though the driving energy is saved somewhat, the demand for energy supplement is rather high. In order to reduce the demand for supplementary energy, we can use motors with larger torque constant and smaller resistance to reduce energy loss (refer to (1) and (3)). Alternatively, we can increase the gear ratio of the gearbox in the master site. With  $N_1$  and  $N_2$  ( $N_1 > N_2$ ) denoting the gear ratios of the gearboxes in the master and slave sites, the electromagnetic power of the master and slave motors can be written as

$$\begin{cases} P_{1\_M} = C_T i N_1 \omega_{in} \\ P_{2\_M} = C_T i N_2 \omega_{out} \end{cases} \quad (12)$$

which suggests that the master motor generates more electromagnetic power than the power required in the slave site when  $\omega_{out}$  equals to  $\omega_{in}$ . If the two gear ratios are matched appropriately, the following relationship can be achieved

$$P_{1\_M} - P_{2\_M} \approx 2(p_a + p_b + p_f) \quad (13)$$

Thus the demand for energy supplement can be reduced greatly. The viability of this method has been verified by practical tests employing geared DC motors of 1271 series (McLennan co. UK) with  $N_1 = 43$  and  $N_2 = 21$  in our experiments.

However, an asymmetric mechanism makes the system is limited to the collocation of master and slave parts, especially when the system works in passive mode. If the great amount of supplementary energy is needed to achieve motion tracking.

The healthy limb to drive the impaired limb. Moreover, the gearbox with a larger gear ratio in the slave site is easily to be destroyed, because it works in the back drivable state in our experiments. In conclusion, when the gearbox with a larger gear ratio is located in the healthy limb side, this

system can work well with a small demand for supplementary energy; however, when the gearbox with a larger gear ratio is located in the impaired limb side, it cannot work ideally, especially in a passive

exercise application. However, if the designed master and slave units can exchange the physical position flexibly, this scheme will be more preferable for rehabilitation robots.

- 2) The system has a perfect motion tracking ability. However, the errors are relatively large at the point of changing the rotational direction. This problem is considered to be resolved by improving the control program.
- 3) In the experiment, encoders were employed to detect the speeds of the master and slave motors, and to calculate requirements of supplementary energy. Actually, we can formulate the relationship between supplementary energy and closed-loop current and apply the formulation along with detected current to calculate the required supplementary energy in practical applications. Hence, the system will do not require any sensors. We can further improve the system's performance, and can enhance the potential for an extensive application in control fields.
- 4) The load-bearing capability of the experimental platform is not enough to drive an impaired limb especially with extremely weak motor function. Therefore, in real applications, the gearboxes with a larger gear ratio should be adopted to increase load-bearing capability. However, the gear ratio should not be too large, because a larger gear ratio will increase the difficulty of driving the impaired limb, and may destroy the gearbox in the slave site where the motor/gear unit is required to be back drivable during the passive training. Gearboxes with the gear ratio of 51 or 66 (Planetary Gearhead GP 32 A) may be able to provide enough driving force to drive the forearm limb to perform a flexion/extension action. The feasibility of these gear ratios should be confirmed with testing experiments in the next step. If the gear ratio is too large to work well in the back driving mode, motors with a relatively high power can be adopted to replace the ones used in this experiment.
- 5) In order to make the system more suitable for the application in rehabilitation robots, a new system with multi-DOF mechanism will be developed using a multi-motor combination in the future work.

## 6. Conclusion

The master-slave control system has several characteristics that make it suitable for application in wearable rehabilitation robots. First, the system realizes force sensing without a force sensor. The patient can feel the resistant or active force of the impaired limb and adjust the input force accordingly to accomplish the movement. Second, the system achieves a kind of energy recycling. Therefore, a lightweight battery will probably supply enough power for the system. This may address the power problem, and relatively reduce the weight of the wearable robots, further make it favorable for the operator wearing a portable robot so as to move around freely in future applications. Third, the equivalent configuration of the master and slave sites enables the system to realize bilateral control, and eliminates the direction limitation for the master and slave manipulator. Furthermore, in the active-assistive exercise or the active-resistive exercise, the assistive force or the resistant force provided by the healthy limb can be regulated in time under the action of motion



consciousness, because the motion is controlled by the patient himself/herself. For example, when the patient want to change the motion trajectory, he/she will make a preparation for changing the force direction of the healthy limb, and making a timely regulation to assist or resist the motion of the unhealthy limb. Otherwise, this scheme also has a great potential for applications in the fields of micro-manipulation, micro-assembly and medical surgery assistant.

## 7. References

- Burgar, C.G.; Lum, P.S.; Shor, P.C. & Van Der Loos, H.F.M. (2000). Development of robots for rehabilitation therapy: the Palo Alto VA/Stanford experience, *Journal of Rehabilitation Research and Development*, Vol. 37, No. 6/2000, pp. 663-673
- Gang, S. & Shuxiang, G. (2006). Development of an active self-assisted rehabilitation simulator for upper limbs, *Proceedings of the World Congress on Intelligent Control and Automation (WCICA)*, Vol. 2, 2006, pp. 9444-9448
- Hogan, N. & Krebs, H.I. (2004). Interactive robots for neuro-rehabilitation. *Restorative Neurology and Neuroscience*, Vol. 22, No. 3, 5/2004, pp. 349-358, 0922-6028
- Hogan, N.; Krebs, H.I.; Rohrer, B.; Palazzolo, J.J.; Dipietro, L.; Fasoli, S.E.; Stein, J. & Volpe, B.T. (2006). Motions or muscles? Some behavioral factors underlying robotic assistance of motor recovery, *Journal of Rehabilitation Research and Development*, Vol. 43, No. 5, pp. 605-618
- Jack, D.; Boian, R.; Merians, A.S.; Tremaine, M.; Burdea, G.C.; Adamovich, S.V.; Recce, M. & Poizner, H. (2001). Virtual reality enhanced stroke rehabilitation, *IEEE Transactions on Neural Systems and Rehabilitation Engineering*, Vol. 9, No. 3, 9/2001, pp. 308-318
- Jeong, Y.; Kim, Y.K.; Kim, K. & Park, J.-O. (2001). Design and control of a wearable robot, *Robot and Human Communication - Proceedings of the IEEE International Workshop*, pp. 636-641
- Krebs, H.I.; Volpe, B.T.; Aisen, M.L. & Hogan, N. (2000). Increasing productivity and quality of care: Robot-aided neuro-rehabilitation, *Journal of Rehabilitation Research and Development*, Vol. 37, No. 6/2000, pp. 639-652
- Li, H. & Song, A. (2008). Force assistant master-slave telerehabilitation robotic system, *Journal of Southeast University*, Vol. 24, No. 1, 3/2008, pp. 42-45
- Lum, P.S.; Burgar, C.G.; Shor, P.C.; Majmundar, M. & Van der Loos, M. (2002). Robot-assisted movement training compared with conventional therapy techniques for the rehabilitation of upper-limb motor function after stroke, *Arch Phys Med Rehabil*, Vol. 83, No. 7, pp. 952-959
- Lum, P.S.; Burgar, C.G. & Shor, P.C. (2004). Evidence for improved muscle activation patterns after retraining of reaching movements with the MIME robotic system in subjects with post-stroke hemiparesis, *IEEE Transactions on Neural Systems and Rehabilitation Engineering*, Vol. 12, No. 2, 6/2004, pp. 186-194
- Nef, T.; Mihelj, M. & Riener, R. (2007). ARMin: A robot for patient-cooperative arm therapy, *Medical and Biological Engineering and Computing*, Vol. 45, No. 9, 9/2007, pp. 887-900
- Peng, Q.; Park, H.-S. & Zhang, L.-Q. (2005). A low-cost portable tele-rehabilitation system for the treatment and assessment of the elbow deformity of stroke patients, *Proceedings of the 2005 IEEE 9th International Conference on Rehabilitation Robotics*, Vol. 28, 7/2005, pp. 149-151

- Reinkensmeyer, D.J.; Dewald, J.P.A. & Rymer, W.Z. (1999). Guidance-based quantification of arm impairment following brain injury: a pilot study, *IEEE Transactions on Rehabilitation Engineering*, Vol. 7, No. 1, 3/1999, pp. 1-11,
- Reinkensmeyer, D.J.; Kahn, L.E.; Averbuch, M.; McKenna-Cole, A.; Schmit, B.D. & Zev Rymer, W. (2000). Understanding and treating arm movement impairment after chronic brain injury: progress with the ARM Guide, *Journal of Rehabilitation Research and Development*, Vol. 37, No. 6/2000, pp. 653-662
- Reinkensmeyer, D.J.; Hogan, N.; Krebs, H.I.; Lehman, S.L. & Lum, P.S. (2000). Rehabilitators, Robots and Guides: New Tools for Neurological Rehabilitation, *Biomechanics and Neural Control of Posture and Movement*, pp. 516-533
- Song, G. & Guo, S. (2006). Development of a novel tele-rehabilitation system, *IEEE International Conference on Robotics and Biomimetics, ROBIO*, 17-20 Dec.2006, pp. 785-789
- Statistics Bureau, Japan. (2007). Statistical handbook of Japan. Available: <http://www.stat.go.jp/english/data/handbook/c02cont.htm>
- van Exel, N.J.A.; Koopmanschap, M.A.; Scholte op Reimer, W.; Niessen, L.W. & Huijsman, R. (2005). Cost-effectiveness of integrated stroke services, *QJM-J. Association of Physician*, Vol. 98, No. 6, 1/2005, pp. 415-425
- Zheng, H.; Davies, R.; Zhou, H.; Hammerton, J.; Mawson, S.J.; Ware, P.M.; Black, N.D. & Harris, N.D. (2006). SMART project: Application of emerging information and communication technology to home-based rehabilitation for stroke patients, *Int.J. Disability and Human Development*, Vol. 5, No. 3, 7/2006, pp. 271-276
- Zhou, H.; Stone, T.; Hu, H. & Harris, N. (2008). Use of multiple wearable inertial sensors in upper limb motion tracking, *Medical Engineering and Physics*, Vol. 30, No. 1, pp. 123-133

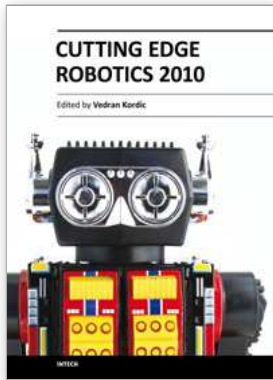

## **Cutting Edge Robotics 2010**

Edited by Vedran Kordic

ISBN 978-953-307-062-9

Hard cover, 440 pages

**Publisher** InTech

**Published online** 01, September, 2010

**Published in print edition** September, 2010

Robotics research, especially mobile robotics is a young field. Its roots include many engineering and scientific disciplines from mechanical, electrical and electronics engineering to computer, cognitive and social sciences. Each of this parent fields is exciting in its own way and has its share in different books. This book is a result of inspirations and contributions from many researchers worldwide. It presents a collection of a wide range of research results in robotics scientific community. We hope you will enjoy reading the book as much as we have enjoyed bringing it together for you.

### **How to reference**

In order to correctly reference this scholarly work, feel free to copy and paste the following:

Tao Liu, Chunguang Li, Kyoko Shibata and Yoshio Inoue (2010). Motion Control of Robots Based on Sensings of Human Forces and Movements, Cutting Edge Robotics 2010, Vedran Kordic (Ed.), ISBN: 978-953-307-062-9, InTech, Available from: <http://www.intechopen.com/books/cutting-edge-robotics-2010/motion-control-of-robots-based-on-sensings-of-human-forces-and-movements>

# **INTECH**

open science | open minds

### **InTech Europe**

University Campus STeP Ri  
Slavka Krautzeka 83/A  
51000 Rijeka, Croatia  
Phone: +385 (51) 770 447  
Fax: +385 (51) 686 166  
[www.intechopen.com](http://www.intechopen.com)

### **InTech China**

Unit 405, Office Block, Hotel Equatorial Shanghai  
No.65, Yan An Road (West), Shanghai, 200040, China  
中国上海市延安西路65号上海国际贵都大饭店办公楼405单元  
Phone: +86-21-62489820  
Fax: +86-21-62489821

© 2010 The Author(s). Licensee IntechOpen. This chapter is distributed under the terms of the [Creative Commons Attribution-NonCommercial-ShareAlike-3.0 License](#), which permits use, distribution and reproduction for non-commercial purposes, provided the original is properly cited and derivative works building on this content are distributed under the same license.