

PUBLISHED BY

INTECH

open science | open minds

World's largest Science,
Technology & Medicine
Open Access book publisher



3,350+
OPEN ACCESS BOOKS



108,000+
INTERNATIONAL
AUTHORS AND EDITORS



115+ MILLION
DOWNLOADS



BOOKS
DELIVERED TO
151 COUNTRIES

AUTHORS AMONG
TOP 1%
MOST CITED SCIENTIST



12.2%
AUTHORS AND EDITORS
FROM TOP 500 UNIVERSITIES



Selection of our books indexed in the
Book Citation Index in Web of Science™
Core Collection (BKCI)

WEB OF SCIENCE™

Chapter from the book *Type 1 Diabetes*

Downloaded from: <http://www.intechopen.com/books/type-1-diabetes>

Interested in publishing with IntechOpen?
Contact us at book.department@intechopen.com

Viruses and Type 1 Diabetes: Focus on the Enteroviruses

Didier Hober, Famara Sané, Karena Riedweg,
Ilham Moumna, Anne Goffard, Laura Choteau,
Enagnon Kazali Alidjinou and Rachel Desaillood

Additional information is available at the end of the chapter

<http://dx.doi.org/10.5772/52087>

1. Introduction

Type 1 diabetes (T1D) is one of the most common chronic diseases in developed countries and represents about 10% of all cases of diabetes. It is caused by a selective destruction of insulin-producing β cells in the pancreas. The disease has two subtypes: 1A, which includes the common, immune-mediated forms of the disease; and 1B, which includes nonimmune forms. In this review, we focus on subtype 1A, which for simplicity will be referred to as type 1 diabetes. [81, 34]. An increasing incidence rate of T1D has been observed for the last few decades especially in young individuals (less than five years old) [163]. The cause of T1D is still unknown. Several factors interact and lead to the development of the disease. An inflammatory islet infiltrate (insulinitis) can be observed at the symptomatic onset of T1D, and reflects the immune response to β -cells [45]. T1D is an autoimmune disease, which implies a role of immune response effectors in the pathogenic processes and a failure of tolerance towards β -cell antigens. The susceptibility to T1D is influenced by genetic factors. More than 20 loci in addition to those located in the human leukocyte antigen (HLA) class II locus (especially DQ and DR) on chromosome 6 are involved. Another contribution to the pathogenesis of the disease could rely on epigenetic modifications (such as DNA methylation) and parent-of-origin effects [11]. Genetic modifications in the population cannot explain the rapidly increased incidence of T1D in most populations. Altogether, the incidence variation from one season to another, the relationship between immigration and disease development, and the differences in incidence in different parts of the world in neighboring populations with similar genetic profiles, suggest that the disease is a result of interaction of genetic and environmental factors [94].

Interplay between immune response, genetic and environmental factors such as nutriment, drugs, toxin and viruses play a role in the pathogenesis of the disease. Several teams paid attention to the relationship between viruses and type 1 diabetes, and their role in the pathogenesis of the disease. A novel subtype of type 1 diabetes called fulminant type 1 diabetes, without evidence of autoimmunity has been observed [61]. In that disease the role of viruses is strongly suspected as well, but is out of the scope of this chapter.

The relationship between type 1 diabetes in human beings and animals and various viruses belonging to different families has been investigated. Enteroviruses are among the viruses most able to be involved in the pathogenesis of autoimmune type 1 diabetes.

After a presentation of the role of various viruses in the disease we will focus on enteroviruses, and then the clinical studies that were conducted to assess the relationship between enteroviruses and autoimmune T1D will be detailed. Thereafter the results of experimental investigations aimed to elucidate the link between these viruses and the disease will be analyzed.

2. Various viruses have been associated with the development of type 1 diabetes

The role of viral infections in the pathogenesis of T1D has long been suspected and several viruses have been associated with T1D in various studies [160, 162]. In humans, observations of acute diabetes succeeding to destruction of β -cells by cytopathic effect of viral infection remain exceptional. Some viruses, as mumps, influenza B virus or human herpes virus 6 have already been reported in cases of acute T1D. Nevertheless, the fact that T1D developed after the infection by such common viruses suggest that factors within the host play more important roles than virus itself in the etiology of T1D [27, 59, 126].

The relationship between viral infection and T1D is mainly based on epidemiological arguments. The incidence of many allergic and autoimmune diseases has increased in developed countries (North-South gradient) over the past three decades, particularly in young children. Concomitantly, there was a clear decrease in the incidence of many infectious diseases in these countries, probably explained by the introduction of antibiotics, vaccination, and an improved hygiene and better socioeconomic conditions [6, 163].

Interestingly, viruses have been reported to be associated with T1D occurrence in animals. Experimental animal models, as BioBreeding (BB)-rat, nonobese diabetic (NOD) mouse or specific transgenic mouse strains, were used to investigate the mechanism by which viruses can modulate diabetogenesis.

2.1. Viruses and human type 1 diabetes

2.1.1. Rubella

Several reports have shown that congenital rubella was associated with induction of islet autoantibodies in 10% to 20% of cases of congenital rubella, within 5 to 25 years [18, 56, 71].

The serum levels of antibodies against measles, mumps, and rubella (MMR) and autoantibodies against pancreas islet cells (ICA), islet cell surface, glutamic acid decarboxylase autoantibodies (GADA), and insulin were determined in 386 school children between 11 and 13 years of age, before and 3 months after vaccination with combined MMR vaccine. It has been shown that children with rubella antibodies before vaccination had higher levels of ICA than seronegative children [98]. However, a study conducted in 2003 showed inconsistent results: in fact, no signs of β -cells autoimmunity (ie detection of ICA, insulin autoantibodies (IAA), antibodies to the tyrosine phosphatase related IA-2 molecule (IA-2 A) and glutamic acid decarboxylase (GADA)) were detected in 37 subjects with congenital rubella syndrome or exposed to rubella virus during fetal life [165]. The role of rubella in the triggering of T1D has been determined in hamsters. This study revealed that an autoimmune process and diabetes developed after rubella virus infection in neonatal hamsters [121]. Some authors suggested the molecular mimicry as a mechanism for rubella virus causing T1D, on the basis of co-recognition of β -cell protein determinants, such as GAD, and various rubella peptides by T-cells [118]. Recently, a clinical study has confirmed a significant association between type 1 diabetes incidence and rubella in children in Italia [120].

2.1.2. Rotavirus

Rotavirus (RV), the most common cause of childhood gastroenteritis, has been suspected to trigger or exacerbate T1D in a few studies. Honeyman *et al.* showed a specific and highly significant association between RV seroconversion and increases in autoantibodies. Serum of 360 children with a parent or sibling with type 1 diabetes had been assayed for IAA, GADA, and IA-2A every 6 months from birth. In all children, 24 children had been classified as high-risk children because they developed diabetes or had at least 2 islet antibodies or 1 islet antibody detected on at least 2 occasions within the study period. In high-risk children, 86% developed antibodies to IA-2, 62% developed insulin autoantibodies, and 50% developed antibodies to GAD in association with first appearance or increase in RV IgG or IgA [70]. In 2002, Coulson *et al.* demonstrated that rotavirus could infect pancreas *in vivo* [35]. In this study, nonobese diabetic (NOD) mice were shown to be susceptible to rhesus rotavirus infection. Pancreatic islets from NOD mice, nonobese diabetes-resistant mice, fetal pigs, and macaque monkeys supported various degrees of rotavirus growth. Human rotaviruses that were propagated in African green monkey kidney epithelial (MA104) cells in the presence of trypsin as previously described [128] replicated in monkey islets only [35]. In another study, the effect of RV infection on diabetes development, once diabetes was established, was determined on NOD and NOD8.3 TCR (transgenic for a T-cell receptor (TCR)) mice. The degree of diabetes acceleration was related to the serum antibody titer to RV. Thus, rotavirus infection aggravated insulinitis and exacerbated diabetes, after β -cell autoimmunity was established [60]. Furthermore, rotavirus was also suspected to contain peptide sequences, in VP7 (viral protein 7), highly similar to T-cell epitopes in the islet autoantigens GAD and tyrosine phosphatase IA-2, suggesting that T-cells directed against RV could induce or amplify islet autoimmunity by molecular mimicry, in children with genetic susceptibility. Honeyman *et al.* also demonstrated that peptides in RV-VP7, similar to T-cell epitopes in IA-2 and GAD65, bound strongly to HLA-DRB1*04. The proliferative responses of T-cells to

rotavirus peptide and islet autoantigen-derived peptides were significantly correlated [72]. Altogether, these observations suggested that RV infection could trigger or exacerbate islet autoimmunity by molecular mimicry.

2.1.3. Mumps

In 1992, Parkkonen et al showed that mumps virus was able to infect β -cells, leading to a minor decrease in insulin secretion in human fetal islet cultures [119]. The infection was invariably associated with an increase in the expression of human leucocyte antigen (HLA) class I molecules, mediated by soluble factors secreted by infected T cells, which could exaggerate the autoimmune process in pre-diabetic individuals by increasing the activity of autoreactive cytotoxic T cells [119]. Moreover, ICA have been observed in 14 out of 30 sera of children with mumps. In most children, the ICA persisted for no more than 2-4 months, although 2 children have been positive for 15 months. Nevertheless, no ICA-positive child acquired diabetic glucose metabolism, apart from one child who had persistent ICA and acquired diabetes mellitus three weeks after mumps infection [62]. Since the introduction of vaccination against MMR in most of occidental countries, several studies have reported on the relation between vaccination at childhood and the development of T1D [41, 78, 79]. Hyoty *et al.* demonstrated that vaccination against MMR in Finland was followed by a plateau in the rising incidence of T1D 6–8 years later suggesting a causal relation between these viral infections and the development of T1D [79]. However, the incidence of T1D continued to rise after the plateau. Other studies hypothesized that childhood vaccination would rather promote the development of T1D. No evidence has been found for the triggering effect of childhood vaccination on the development of T1D later in life [41, 78]. Hyoty et al. described a shared epitope, a 7 amino acid-long sequence (YQQQGRL), in mumps virus nucleocapsid and in MHC class II-associated invariant chain, which might cause immunological cross-reactivity between these molecules [80].

2.1.4. Human Endogenous Retroviruses

Human Endogenous Retroviruses (HERVs) are sequences which occupy about 10% of the human genome and are thought to be derived from ancient viral infections of germ cells. In some medical conditions, HERVs genes could be transcribed, expressed in protein and could be responsible of the development of autoantibodies that might react against host proteins. As a result, these mechanisms could lead to autoimmune diseases, such as T1D. HERVs may also dysregulate the immune response by being moved and inserted next to certain genes involved in immune regulation whose expression would be consequentially altered. Finally, HERVs are known to induce proinflammatory cytokines production, as IL-1 β , IL-6, or TNF- α , by cells, such as monocytes [10]. The HERV-K18 variant has been shown to encode for a superantigen (SAg) that is recognized by T-cells with TCR V β 7 chains and causes dysregulation of the immune system. HERV-K18 mRNA has been found to be enriched in tissues of patients with acute T1D. HERV-K18 transcription and SAg function in cells capable of efficient presentation are induced by proinflammatory stimuli and may trigger progression of disease to insulinitis or from insulinitis to overt diabetes [101]. The HERV-

K18 variant, which is transcriptionally silent, could be directly transactivated by EBV (Epstein Barr Virus) or HHV-6 (human herpes virus 6), or alternatively through the EBV or HHV-6- induced production of the IFN- α [143, 144].

Rubella virus, rotavirus, mumps virus and endogenous retroviruses are RNA viruses whose role in type 1 diabetes has been suspected. In addition to RNA viruses, it has been reported that DNA viruses as well could be involved in the development of the disease as described in the following paragraphs.

2.1.5. Cytomegalovirus

In 1988, Numazaki et al showed that cytomegalovirus (CMV) was able to infect tissue monolayer cultures of human fetal islets [112]. CMV infection apparently did not cause direct destruction of β -cells but was leading to changes in production of insulin [112]. Hillebrands *et al.* demonstrated that R(at)-CMV accelerated onset of diabetes without infecting pancreatic islets in BB-rats and suggested that virus-induced recruitment of peritoneal macrophages to the pancreas triggered the accelerated development of insulinitis by enhancing activation of T-cells in pancreas [65]. In 2003, van der Werf et al indicated that R-CMV induced a very strong T-cell proliferative response in BB-rats suggesting that R-CMV might directly activate autoreactive T-cells resulting in accelerated onset of diabetes [161]. In 2010, Smelt et al demonstrated that RCMV induced a low, persistent infection in rat β -cells, associated with an increasing β -cell immunogenicity, which might be an essential step in β -cells destruction and in the development or the acceleration of the onset of T1D [137].

Concerning the role of Human CMV (HCMV) in diabetogenesis, [64] postulated that there is T-cell cross-reactivity between Human CMV (HCMV) and GAD65 in pancreatic islet β -cell. HCMV-derived epitope could be naturally processed by dendritic cells and recognized by GAD65 reactive T-cells. Thus, HCMV may be involved in the loss of T-cell tolerance to autoantigen GAD65 by a mechanism of molecular mimicry leading to autoimmunity [64]. In 2008, Aarnisalo et al analysed specific anti-CMV IgG antibodies in 169 serum samples from children who had developed the first T1D-associated autoantibody by the age of 2 years, and, in parallel, in 791 serum control from healthy children [1]. No association between perinatal CMV infection and progression to T1D was observed. This study concluded that perinatal CMV infections were not particularly associated with early serological signs of beta cell autoimmunity or progression to T1D in children with diabetes risk-associated HLA genotype [1]. However, serological, immunological, histological signs of autoimmunity and allograft rejection appeared concomitantly with early CMV infections in one type 1 diabetic patient receiving pancreas allograft. This observation suggests that persistent CMV infections might be relevant to the pathogenesis of type 1 diabetes [177].

2.1.6. Parvovirus B19

Several cases of autoimmune disease occurrence after an acute infection with parvovirus B19 have been reported. Kasuga *et al.* reported a case of a young adult who developed new onset T1D after an infection with parvovirus B19. Serum levels of B19 IgM and antibodies to the diabetic autoantigen IA-2 were significantly elevated. The authors noted homology in amino acid sequences between B19 and the extracellular domain of IA-2 [88, 113]. Munakata

et al described the case of a 40-year-old Japanese woman, in which three autoimmune diseases occurred after acute parvovirus B19 infection: rheumatoid arthritis, T1D and Graves' disease [106]. Some authors attempted to explain these observations. Parvovirus B19 is known to promote a T-cell-mediated lymphoproliferative response, through the presentation by HLA class II antigen to CD4 cells and thus could theoretically generate T-cell-mediated autoimmunity [166]. Vigeant et al suggested that parvovirus B19 infection may lead to chronic modulation of the autoimmune response in predisposed individuals [164].

Although correlations between T1D and the occurrence of a viral infection that precedes the development of the autoimmune disease have been recognized, mechanisms by which viruses activate diabetogenic processes are still elusive and difficult to prove in humans. Studies of animal virus-induced T1D provide a lot of information concerning the possible role of virus infections in the induction of T1D.

2.2. Viruses and animal type 1 diabetes

2.2.1. *Encephalomyocarditis virus*

A number of studies provide clear evidence that encephalomyocarditis virus (EMCV), belonging to the *Cardiovirus* genus of the *Picornaviridae* family, is able to induce very rapid onset of diabetes in mice. Based upon this evidence, EMCV-induced diabetes model has been proposed as a model of fulminant T1D [135]. Several studies determined the existence of two main variants of EMCV: the nondiabetogenic variant EMC-B virus, and the diabetogenic variant EMC-D virus. EMCV-D has preferential tropism for pancreatic β -cells and can induce diabetes in selective mouse strains, such as DBA/2 [102]. Nucleotide sequence analysis showed that EMC-D virus (7829 bases) differs from EMC-B virus (7825 bases) by only 14 nucleotides: two deletions of 5 nucleotides, 1 base insertion, and 8 point mutations. Further studies revealed that only the 776th amino acid, alanine (Ala-776), of the EMC virus polypeptide, located at position 152 of the major capsid protein VP1, is common to all diabetogenic variants. In contrast, threonine in this position (Thr-776) is common to all nondiabetogenic variants [176]. A single point mutation at nucleotide position 3155 or 3156 of the recombinant EMC viral genome, resulting in an amino acid change (Ala-776 in Thr-776), leads to the gain or loss of viral diabetogenicity [84]. A three-dimensional molecular modeling of the binding site of the EMC viral capsid protein VP1 revealed that the surface areas surrounding alanine (or glycine) at position 152 of the VP1 was more accessible, thus increasing the availability of the binding sites for attachment to β -cell receptors, resulting in viral infection and the development of diabetes [85]. Baek et al. showed that macrophages, especially mac-2 positive macrophages, were rapidly recruited in pancreas at the early stage of EMC-D virus infection, playing a central role in the process of pancreatic islets destruction in SJL/J mice [8, 9]. Recently, Mc Cartney et al. found that melanoma differentiation associated gene-5 (MDA5), a sensor of viral RNA eliciting IFN-I responses, IFN- α , and Toll-Like Receptor 3 (TLR3) were both required to prevent diabetes in mice infected with EMCV-D. In Tlr3^{-/-} mice, a diabetes occurred due to impaired type 1 IFN responses and β cell damage induced directly by virus, rather than autoimmune T cells. Mice lacking just 1 copy

of Mda5 developed transient hyperglycemia when infected with EMCV-D. Thus, in the case of EMCV-D which infects and damages directly the pancreatic β cells, optimal functioning of viral sensors and type 1 IFN responses are required to prevent diabetes [102].

2.2.2. *Kilham rat virus*

Ellerman et al. demonstrated the ability of Kilham rat virus (KRV), an environmentally ubiquitous rat parvovirus, to precipitate autoimmune diabetes in BioBreeding Diabetes-Resistant (BBDR) rats that were not susceptible to spontaneous diabetes [47]. Chung et al. showed the important role of macrophages and macrophage-derived cytokines (IL-12, TNF- α , and IL-1 β) in the KRV-induced autoimmune diabetes in the BBDR rats [29]. As it had been previously shown, KRV did not directly infect β -cells. Thus, Choung et al. investigated the process by which KRV induced autoimmune pancreatic cells destruction. They discovered that it was rather due to a disrupted immune balance: Th1-like CD45RC+CD4+ and cytotoxic CD8+ T-cells were up-regulated whereas Th2-like CD45RC-CD4+ T-cells were down-regulated. Thus, KRV might be responsible for the activation of autoreactive T cells that are cytotoxic to beta cells, resulting in T cell-mediated autoimmune diabetes. In the same study, this group demonstrated that KRV-induced autoimmune diabetes in BBDR rats was not due to molecular mimicry [30]. Zipris et al. reported that infection by KRV or H-1, a close homologue virus of KRV, induced similar humoral and cellular immune responses in BBDR rats and Wistar Furth (WF) rats. Nevertheless, only KRV induced a decrease in splenic CD4+CD25+ T cells (regulatory T cells or Treg) able to suppress autoreactivity, in both rat strains. KRV was able to induce diabetes in BBDR rats but not in WF rats. The disease was associated with accumulation of non proliferating Treg in pancreatic lymph nodes. Together these data suggest a virus- and rat strain- specific mechanism of KRV-induced diabetes in genetically susceptible rats as BBDR rats, through an alteration of T cell regulation. It appears that Treg are no longer able to inhibit autoreactive T cells activation [178]. It has also been shown that proinflammatory cytokines IL-6 and IL-12p40 were produced by spleen cells cultured *in vitro* in the presence of KRV in BBDR and WF rats. Ligation of TLR9 with CpG DNA induced the same pattern of cytokine production. In response to both KRV and CpG DNA, spleen cell populations enriched for B cells (CD45R+) secreted significantly more IL-12p40 than populations enriched for non B-cells (CD45R-). KRV was also able to stimulate Flt-3L bone marrow-derived dendritic cells (DCs) to produce IL-12p40 *in vitro*. Moreover, genomic DNA isolated from KRV, which is a single-strand DNA, induced the production of IL-12p40 in spleen cells from BBDR rats. Thus, the ligand within KRV that induces IL-12p40 secretion in spleen cells is viral DNA. Using appropriate inhibitors of TLR-signaling pathways, Zipris et al. indicated that the cytokine production by splenic cells was Protein Kinase R (PKR) and NF- κ B dependent, whose activation leads to type I IFN production. KRV-induced secretion of IL-12p40 by BBDR spleen cells was inhibited by specific TLR9 inhibitors, as iCpG, and by chloroquine, which is a known inhibitor of endosomal acidification, essential step for the recruitment of TLR9 in the lysosomal compartment. Moreover, genomic DNA isolated from KRV induced the production of IL-12p40 in Flt-3L-induced DCs derived from wild-type BBDR rats but not TLR9-deficient mice. Finally, administration of chloroquine to virus-infected BBDR rats decreased the incidence of diabetes

and decreased blood levels of IL-12p40. These data indicates that the TLR9 -signaling pathway is implicated in the KRV-induced innate immune activation and participates to the development of autoimmune diabetes in the BBDR rat [179, 13].

EMC and KRV are natural viral pathogens of rodent that brought a lot of information as far as the virus-induced pathogenesis of T1D. The role of these viruses in the human T1D has not been reported, however, the Ljungan virus is another rodent virus that has been suspected to be involved in human type 1 diabetes.

2.2.3. *Ljungan virus and human parechoviruses*

The Ljungan virus (LV) is a RNA virus discovered in Sweden in the mid-1990s in rodents (*Myodes glareolus*; formerly *Clethrionomys glareolus* called "bank vole"). This virus belongs to the Parechovirus genus within the Picornaviridae family. Niklasson et al. described the occurrence of T1D in 67 wild bank voles after 1 month of captivity in laboratory: diabetic animals showed clinic signs of diabetes (persistent hyperglycemia with weight loss, ketosis, and hyperlipidemia) and specific β -cell destruction associated with signs of autoimmunity: increased levels of autoantibodies to GAD65, IA-2, and insulin. The disease was correlated with LV antibodies. Moreover, LV antigen was detected by immunocytochemistry in the islets of diabetic bank voles. In parallel, two groups of new onset diabetic children were studied: the first group represented a total of 53 children which were diagnosed with T1D between 1992 and 1995, and the second group was composed of 289 children with newly diagnosed T1D between 1995 and 2000. The study showed increased levels of LV antibodies in newly diagnosed T1D children indicating a possible zoonotic relationship between LV infection and human T1D [109].

In addition to type 1 diabetes, viruses could be involved in the development of type 2 diabetes. Indeed, Niklasson et al. demonstrated that a type 2 diabetes-like disease could be induced by LV in a CD-1 mouse model. Pregnant CD-1 mice were infected with LV and kept under not stressful conditions. After weaning, puberty male mice were kept under stress (all males in the same cage) or not (animals in individual cage). All male mice received glucose (100 g/l) in the drinking water. Only animals infected in utero and kept under stress developed diabetes. Thus, in these animals, viral infection in utero, in combination with stress in adult life could induce diabetes in males [110]. In 2007, Blixt et al. investigated the functional characteristics of pancreatic islets, isolated from female and male bank voles considered as infected by LV. About 20% of all specimens were classified as glucose intolerance/diabetes (GINT/D) following a glucose tolerance test. Of these animals the majority became diabetic by 20 weeks of age, and GINT/D animals had increased serum insulin levels. Functional differences, concerning insulin content, capacity to synthesize (pro) insulin, secrete insulin and metabolize glucose, were observed between normal and GINT/D animals as well as between genders. The increased serum insulin level and the increased basal islet insulin secretion in GINT/D animals suggests that the animals had developed a type 2 diabetes probably due to LV infection associated with stress in laboratory [12].

Human parechoviruses, like LV, belong to the Parechovirus genus; they have also been implicated in the development of T1D in humans. In a recent nested case-control study, the

“Environmental Triggers of Type 1 Diabetes: The MIDIA study”, stool samples from 27 children who developed islet autoimmunity (repeatedly positive for two or three autoantibodies) and 53 children matched for age and community of residence (control group) were analyzed for human parechovirus using a semi-quantitative real-time polymerase chain reaction every month from the 3rd to the 35th month. Sera of children were tested for autoantibodies against GAD, IA-2, and insulin every 3 months until the age of 1 year and every 12 months thereafter. There was no significant difference in the number of infection episodes between the two groups. There was also no significant difference in the prevalence of human parechovirus in stool samples throughout the study period, except in samples collected 3 months prior to seroconversion, in which 16/77 samples (20.8%) from cases had an infection as opposed to 16/182 (8.8%) samples from controls (OR = 3.17, p = 0.022) [148].

Various viruses were reported to be associated with human T1D: rubella and mumps virus, rotavirus, retrovirus, human parechovirus, cytomegalovirus and parvovirus B19 (table 1). In addition, viruses were reported to be associated with animal T1D: EMCV, KRV and LV, the role of which in human type 1 diabetes has also been studied (figure 2). Using animal models, as BB-rats, NOD mice or specific transgenic mouse strains, studies suggested different mechanisms by which viruses may be involved in the initiation or modulation of autoimmune process. These models suggested that a direct infection of islets, responsible for the release of autoantigens, could explain the activation of T-cells and the development of autoimmunity. Another hypothesis supported by some studies was the concept of molecular mimicry between virus and β -cells: a normal immune response against a viral antigen would become pathogenic for β cells due to the existence of structural homologies with the pancreatic antigen. In addition to their possible role in the activation of β -cell-reactive T cells, viruses can reduce the capacity of Treg cells to maintain tolerance. Together, these studies suggest that viruses through different mechanisms may trigger T1D and/or may participate in the amplification of the autoimmune process. In addition to the viruses presented in this section, the major candidates are enteroviruses. Therefore the rest of this review will be focused on these viruses.

| | RNA virus | DNA virus | |
|------------------------|--|--|--|
| Human type 1 diabetes | <i>Togaviridae</i> Rubella virus <i>Paramyxoviridae</i> Mumps virus <i>Picornaviridae</i> Parechovirus Enterovirus | <i>Reoviridae</i> Rotavirus <i>Retroviridae</i> HERVs | <i>Herpesviridae</i> Cytomegalovirus <i>Parvoviridae</i> Parvovirus B19 |
| Animal type 1 diabetes | Encephalomyocarditis virus Ljungan virus | | Kilham rat virus |

Table 1. Viruses involved in human and animal type 1 diabetes grouped according to their genome and their family (in red).

3. Presentation of enteroviruses

3.1. Classification of human enteroviruses

The Picornaviridae family consists of 9 genera: Erbovirus, Kobuvirus, Teschovirus, Aphovirus, Cardiovirus Hepatovirus, Parechovirus, Enterovirus. Human pathogens are in the four last-mentioned genera. Human enteroviruses were previously classified on the basis of serologic criteria into 64 serotypes distributed as: poliovirus (PV), coxsackievirus A (CV-A), coxsackievirus B (CV-B), echovirus and other enteroviruses. The International Committee on Taxonomy of Viruses (ICTV) proposed a classification based on their phylogenetic relations encompassing 4 species, HEV-A, B, C, D, which include various serotypes (table 2). Recently, the former human rhinovirus species have been moved to the Enterovirus genus.

| Species (number of serotypes) | Representatives |
|--------------------------------------|---|
| Human enteroviruses A (12) | Human coxsackievirus A2-8, A10, A12, A14, A16 Human enterovirus 71 |
| Human enteroviruses B (36) | Human coxsackievirus A9 Human coxsackievirus B1-6 Human echovirus 1-7, 9, 11-21, 24-27, 29-33 Human enterovirus 69 |
| Human enteroviruses C (11) | Human polioviruses 1-3 Human coxsackieviruses A1, A11, A13, A15, A17-22, A24 |
| Human enteroviruses D (2) | Human enterovirus 68, 70 |
| Human rhinoviruses A (75) | |
| Human rhinoviruses B (25) | |
| Human rhinoviruses C (48) | |
| Unclassified enteroviruses (over 50) | |

Table 2. Classification of human enteroviruses, adapted from www.picornaviridae.com

3.2. Structure of enterovirus particles

Picornaviridae particles are small (30 nm), icosahedral, non-enveloped viruses with a single-strand positive RNA genome (approximately 7 000- 8 500 nucleotides) (figure 1). The crystal structure of diverse representatives of the family have been solved [69, 2]. The fundamental capsid architecture is the same in all members of the family. The capsid is composed of 60 copies of each four structural proteins VP1 to VP4 in icosahedral symmetry and protects the single strand genomic RNA and associated viral proteins [138]. In each case, VP1, VP2 and VP3 made of 240 to 290 residues (32.4-39.1 kDaltons) constitute the outer surface of the capsid. They are taking the form of eight-stranded antiparallel β sheet structures with a “jelly

roll" topology. In the case of enteroviruses and rhinoviruses, VP1 contains a cavity, or pocket, accessible from a depression on the outer surface of the virus capsid. VP4 is a shorter protein around 70 residues (7 kDaltons) lies across the inner face of the capsid with its N-terminus close to the icosahedral fivefold axis and its C-terminal close to the threefold axis [105]. The N-terminal residue of VP4 in all picornaviruses is covalently linked to the inner surface of the capsid defining a channel through the inner and outer surfaces.

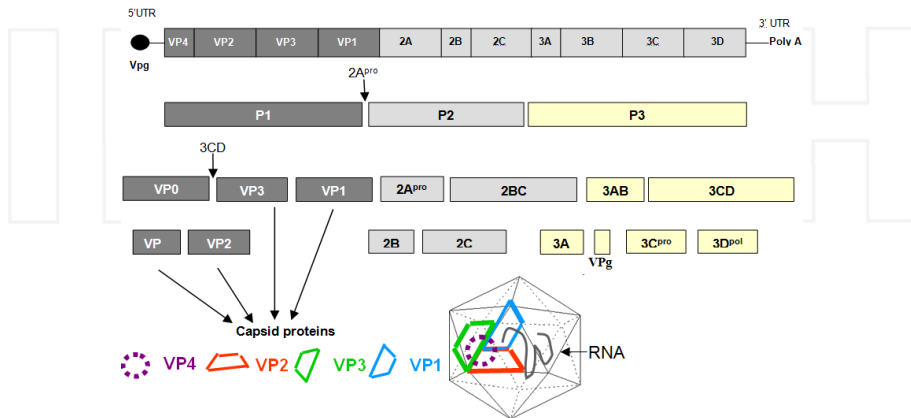

Figure 1. Organisation of the enterovirus genome, polyprotein processing cascade and architecture of enterovirus capsid The genome of enteroviruses contains one single open reading frame flanked by a 5'- and 3' untranslated regions (UTR). A small viral protein, VPg, is covalently linked to the 5' UTR. The 3'UTR encoded poly(A) tail. The translation of the genome results in a polyprotein which is cleaved into four structural proteins (dark gray) and seven non-structural proteins (light gray and yellow). The sites of cleavage by viral proteinases are indicated by arrows. The four structural proteins adopt an icosahedral symmetry with VP1, VP2 and VP3 located at the outer surface of the capsid and VP4 at the inner surface. The single strand genomic RNA is located inside the capsid.

3.3. Viral proteins of enterovirus: synthesis and functions

All picornaviruses have a similar genome organization consisting of a molecule of approximately 7,500 to 8,000 nucleotides (figure 1). The RNA genome is organized with one single large open reading frame preceded by a long 5'-untranslated region (5' UTR) [97]. It contains a 3' poly(A) tail with a variable length from 65 to 100 nt. The virion RNA has a virus-encoded peptide, VPg, covalently linked to the 5' end of the viral genome. Translation of the RNA genome yields a polyprotein of approximately 2,200 amino acids. An early cotranslational cleavage of the polyprotein by the viral 2A protease ($2A^{pro}$) releases a precursor protein P1 from the N terminus of the polyprotein. The P1 protein contains all the capsid protein sequences. Subsequent cleavage of P1 by the viral 3CD protease ($3CD^{pro}$) produces the capsid proteins VP1 and VP3 and the immature capsid protein VP0. Finally, the immature protein VP0 is cleaved to VP4 and VP2. There is no known protease requirement for this cleavage. From the P2 region, protein 2A may have an unidentified function in viral RNA synthesis. Protein 2B and its pre-

cursor 2BC have been suggested to be responsible for membranous alteration in infected cells. From the P3 region, two precursors are synthesized: 3AB and 3BC. The precursor 3AB is a multifunctional protein principally involved in the membrane association of replication complex. Protein 3A is a membrane binding protein that plays a role in inhibiting cellular protein secretion. Protein 3B (VPg) is a small peptide containing 21 to 23 amino acids, which is covalently linked with the 5'UTR. The precursor 3CD exhibits protease activity and is capable of processing the P1 precursor region. Protein 3C is the protease responsible for the majority of polyprotein cleavages. Protein 3D has the RNA-dependent-RNA polymerase activity and is one of the major components of the viral RNA replication complex.

3.4. Enterovirus lifecycle

The first stage of picornavirus infection of susceptible cells is mediated by the interactions of viral capsid with specific receptor on the cell membrane (figure 2). Receptors used by different picornaviruses include members of the immunoglobulin-like family, the low density lipoprotein receptor (LDLR) family (used by minor group of rhinovirus), the complement control family (used by certain rhinovirus), the integrin family of cell adhesion molecules (receptors for aphthovirus family) and the T cell immunoglobulin domain mucin-like domain receptors (TIM-1), receptor for hepatitis A virus, [159].

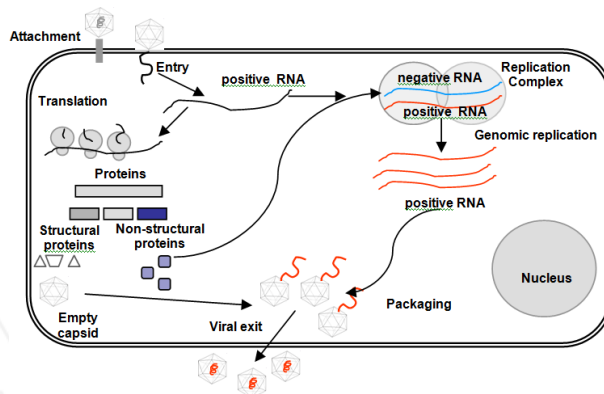

Figure 2. Enterovirus lifecycle.

The group of immunoglobulin-like molecules includes several well characterized receptors for viruses of the enterovirus genus. For example, intercellular adhesion molecule-1 (ICAM-1) is the receptor for major group human rhinoviruses (HRVs), the Coxsackie and adenovirus receptor (CAR), a component of the tight junction between cells in intact epithelium, is the common receptor for Adenoviruses and Coxsackieviruses. These molecules are all type 1 membrane glycoproteins encompassing, for CAR, two extracellular immunoglobulin-like (Ig-like) domains, a transmembrane domain, and a cytoplasmic domain. The first Ig-like domain is responsible for virus binding. The interactions of the re-

ceptor with virus capsid induce conformational modifications of capsid proteins and cellular receptor that initiate the process of viral entry and genome delivery to the cytoplasm. In brief, receptor binding triggers capsid rearrangements that result in the externalization of VP4 and the N-terminus of VP1. At the same time, released VP4 also interacts with the membrane. VP1 and/or VP4 form a membrane pore through which the genomic RNA is transported into the cytoplasm [159].

The enterovirus genome is a positive stranded RNA that can be used as messenger RNA and immediately translated by the host cell to produce specific viral proteins. The viral genomic RNA is then transcribed into a complementary negative RNA, which is used as a template to synthesize new strands of genomic positive RNA. Enterovirus infection induces vesicles in infected cell that are localized in the perinuclear region of the cell and are thought to be the sites of RNA replication. These vesicles clusters where viral RNA can be detected have been referred to as replication complexes (RCs). Viral RNA replication occurs at the surface of vesicles. RCs derive from cellular membranes participating to endoplasmic reticulum-to-golgi traffick, hijacked by viral proteins [19]. The viral protein 3A plays a role in the formation of the RCs. Viral proteins synthesis and genomic RNA replication are catalyzed by RNA-dependent RNA polymerase 3D and several other viral proteins, 2B, 2C and 3AB, also participate in RNA replication [4]. It has been suggested that genome replication and encapsidation are coupled [111]. To date, the VPg protein has been implicated as a determinant of encapsidation. The encapsidation of the RNA is associated to the processing of the immature protein VP0 to yield VP4 and VP2. There is no known protease requirement for this cleavage, and it is thought to be autocatalytic, depending only on the capsid proteins themselves and perhaps the viral RNA. The cleavage of VP0 to form the virion is associated with a significant increase in the stability of the particle [68]. It is commonly accepted that enteroviruses exits the cell by lysis of the host cell. However, newly synthesized virus can be detected long before lysis. In addition, enteroviruses are able to establish persistent infection without killing the cell [32]. Both observations argue in favor of alternative exit pathways probably with activation of the apoptotic program in enterovirus-infected cells. Enteroviruses have a large distribution in the world. Fecal-oral route via the ingestion of contaminated water or food is the major way of enterovirus transmission. Enterovirus infections are generally asymptomatic, but some of them, especially the one due to coxsackievirus B (CV-B), have been associated with acute manifestations (around 20 diseases such as non-specific febrile disease, cutaneous symptoms, meningitis, encephalitis, pericarditis etc.). In addition, their role in chronic diseases, like chronic myocarditis, dilated cardiomyopathy, and T1D is strongly suspected [81].

4. Relationship between enteroviruses and autoimmune type 1 diabetes: clinical studies

Enterovirus infections are among the main environmental risk factors for autoimmune T1D and they have been diagnosed more frequently in T1D patients than in healthy subjects. In this section we report the different studies conducted to investigate the relationship between

enteroviral infection and T1D. These studies have used different techniques to detect enteroviruses or their components (RT-PCR, cell culture, immunohistochemistry, in situ hybridization...) in blood (serum, plasma and leucocytes), stools, pancreas, intestine. Several studies throughout the world have displayed a relationship between enterovirus infection and the development of T1D (table 3).

We will present the detection of enteroviruses and/or their components in various biological samples in patients with clinical type 1 diabetes first, and thereafter in patients with signs of autoimmunity and/or risk of developing the disease.

4.1. Enterovirus in biological samples from patients with type 1 diabetes

4.1.1. Whole blood

The presence of enteroviral RNA in whole blood of adult patients with T1D has been reported by our group [5]. Viral RNA was detected by RT-PCR in 42% (5/12) of patients with newly diagnosed T1D ($p < 0.01$ vs healthy subjects) and in 8% (1/12) of previously diagnosed T1D patients suffering from metabolic ketosis decompensation ($P = 0.07$ vs patients with newly diagnosed T1D). RT-PCR was negative in the group of healthy subjects and patients with type 2 diabetes. Sequencing of amplified cDNA displayed that circulating enteroviral RNA in these patients had strong homologies with CVB (CVB3 in 4 patients with newly diagnosed T1D, CVB4 in another one, and in one previously diagnosed patient). This study demonstrated that enteroviral RNA could be detected in blood of adult patients at the onset or in the course of T1D.

An other study, performed also by our group, encompassed 56 patients with T1D (25 children whose average age was 13 years and 31 adults with an average age of 37 years), and 37 control subjects divided into 2 groups: the first comprising 24 subjects without any infectious, immunological or metabolic disease, the second group includes 13 patients with T2D [23]. The presence of IFN- α mRNA was detected by RT-PCR in whole blood of 42 out of 56 patients (75%) but in none of controls, and IFN- α was detected by a sensitive immunoassay in serum of 39 out of 56 patients. Enteroviruses-RNA sequences were detected in 50% (21/42) of patients with IFN- α in their blood, but not in patients without any IFN- α in their blood. The detection of enteroviral RNA was positive in 25% (3/12) of children with newly diagnosed T1D, 30% (4/13) of children with previously diagnosed T1D, 50% (10/20) of adult patients with newly diagnosed T1D and 36% (4/11) of adult patients with previously diagnosed T1D. Sequencing of amplified cDNA displayed that circulating enteroviral RNA in these 21 patients had strong homologies with CVB (CVB3 in 8 patients; CVB4 in 8 patients; CVB2 in 5 patients). The results of sequencing of circulating enteroviral RNA were concordant with the results of anti-CVB neutralizing antibodies assay. Otherwise, there was no significant relationship between enterovirus detection and age of patients or the pattern of disease (metabolic decompensation or not)

In Sweden, blood spots are routinely taken on days 2-4 of life for analysis of inherited metabolic diseases in all newborns and are stored in a biobank. From this biobank, a Swedish study investigated enteroviral RNA in blood spots from 600 children in the Swedish child-

hood diabetes register [39]. Six hundred healthy children were included as controls. Viral RNA was found in 27 out of 600 (4.5%) diabetic children compared to 14 out of 600 (2.3%) control children ($p=0.04$).

4.1.2. Serum and plasma

The polymerase chain reaction, targeting the 5' non coding region of enteroviral RNA was first used in an English study to detect viral genome in serum taken from 14 children at the onset of T1D and 45 control children matched for age, sex, date of specimen receipt and, as far as possible, geographic area [31]. In this study, a significant greater number of diabetic children had positive PCR results compared with controls (64% vs. 4%). Sequencing of enterovirus PCR products from six positive patients showed a significant homology with coxsackie B3 and B4 viruses, and some common patterns were observed among the sequences from infected diabetic children.

An English team investigated the relationship between enterovirus RNA and T1D in children [108]. One hundred ten children (aged 0-15 years with an average of 7.1 years) with newly diagnosed T1D were recruited. Detection of enterovirus RNA in serum collected in the week after diagnosis was based on a RT-PCR amplifying the 5' noncoding region of enterovirus genome. Hundred and eighty-two control children were matched to cases by age (average age: 6.6 years), sex and date of serum collection at the same hospital. The number of newly diagnosed children with a positive RT-PCR was significantly higher than in the control group (27% versus 4.9%, $p < 0.005$). Moreover, a significant proportion of diabetic children with a positive RT-PCR were of very young age. Indeed, enteroviruses were detected in 37% (20/54) of T1D children aged under 7 years, whereas only 4.6% (5/111) of corresponding control children were positive for enterovirus RNA ($p < 0.005$). For diabetic children older than 7 years, 17.8% (10/56) were found to be positive for enterovirus RNA sequences, while viral RNA was detected in only 5.6% (4/71) of corresponding controls ($p < 0.05$).

A French study evaluated the possible role of enteroviruses infections in the pathogenesis of T1D (Coutant et al., 2002). Sixteen newly diagnosed T1D children were included in this study. Forty nine control children matched for age, sex, date of venous collection and geographic area. A highly sensitive RT-PCR was used to investigate RNA in serum from patients and controls. Neutralization antibodies to coxsackies viruses B1 to B6 were used to characterize the positive PCR samples. Enterovirus RNA was detected by PCR in only 2 of the 16 newly diagnosed T1D children and in only one of the 49 matched controls ($p < 0.1$). Neutralization assay could not detect antibodies against coxsackiesviruses B1 to B6.

Two hundred and six newly diagnosed T1D children and 160 controls were included in an Australian study [37]. Enterovirus-RNA was found in either plasma or stool in 30% (62/206) of newly diagnosed T1D but only in 4% (6/160) of controls ($p < 0.001$). Case patients, positive for enterovirus RNA had lower C-peptide levels ($p = 0.04$). Case children with enterovirus RNA levels were more likely to have a severe diabetic ketoacidosis ($p = 0.03$). Enteroviruses were detected in fewer children with HLA haplotype DRB1 * 03 DQB1 * 02 ($p = 0.02$) sug-

gesting that the likely role of enteroviruses in the development of diabetes is important in some patients with specific genetic risk.

An Egyptian study included 70 diabetic children who were classified into 2 groups: the first group (I), 40 patients with newly diagnosed diabetic patients (less than one year), the second group (II), 30 children with diabetic patients with more than one year duration of disease [100]. In the control group there were 30 normal healthy children. Enterovirus infection was detected by viral culture of serum samples and confirmation of the results of tissue culture isolation was done by RT-PCR. In addition, anti-CVB IgM and IgG antibodies were searched by enzyme immuno assay. Enterovirus was isolated in group I (47.5%) and group II (23.3%). Neutralization test revealed that most of cases were coxsackievirus B4. In this study, coxsackievirus B IgM antibodies were significantly higher in diabetic patients of group I than those in group II ($p < 0.01$) but there was no significant difference between group I and group II regarding IgG positivity.

A Japanese case-control study encompassed 61 patients with T1D aged 9 months to 40 years and 58 non diabetic subjects aged 1 month to 40 years whose serum was collected the same year [90]. A highly sensitive RT-PCR was used to investigate enterovirus RNA in serum samples. Moreover, neutralizing antibodies against Coxsackievirus and antibodies to GAD were measured and compared with the viral load and the enterovirus genotype. The detection of enterovirus was positive in 23 out of 61 patients (37.7%) and in 2 out of 58 controls (3.4%). The positivity of RT-PCR was decreasing by years gradually after the occurrence of T1D, there was neither gender nor age tendency. The sequence analysis of PCR amplicons displayed strong homologies with coxsackievirus B4 in 13 patients out of 23, and the level of neutralizing anti-CVB4 antibodies was significantly high in positive patients in RT-PCR. There was no relationship between the viral load in serum and antibodies against GAD.

A German group searched the enterovirus RNA by RT-PCR in the serum of diabetic children taken soon after the diagnosis of diabetes [104]. Seventeen out of 47 (36%) newly diagnosed diabetic cases were positive for enteroviral RNA whereas 2 out of 50 control subjects were positive ($p < 0.001$).

Cuba is a country with a low incidence of T1D and with a high circulation of enteroviruses. In a Cuban study, the frequency of enteroviral RNA detection by RT-PCR was significantly higher in newly diagnosed T1D children whose diagnosis was made within 10 days before inclusion [26.5% (9/34)] compared to controls [2.9% (2/68)], matched for age, gender, geographic origin and date of serum collection ($p = 0.0007$) [127]. Enterovirus detection was more likely associated with severe diabetic ketoacidosis at onset ($\text{pH} < 7.1$, $p = 0.03$) and high titres of autoantibodies against ICA ($p < 0.05$).

4.1.3. Leucocytes and other biological samples

An English study included 17 newly diagnosed patients with T1D, 38 previously diagnosed patients with T1D (the median duration of T1D was 4 years) and 43 age and sex matched non-diabetic controls [53]. Enterovirus RNA was detected by PCR in peripheral blood mononuclear cells in 41 % of newly diagnosed patients with T1D, 39% of previously diagnosed

patients and 31% of non diabetic controls. This study showed no difference between diabetic patients and controls regarding the frequency of infection by enterovirus. Whether enteroviruses acted as non-specific agents with an abnormal immune response of the host, is a question raised by the authors of this study.

In a Swedish group, Yin and colleagues used RT-PCR to detect enterovirus RNA in PBMC (peripheral blood mononuclear cells) from 24 newly diagnosed children patients [171]. The 24 control children were matched for age, sex and geographical location without evidence of ongoing infection. RT-PCR was performed with primers (groups A and B) corresponding to conserved areas in the 5' non-coding region. With group A primers, 50% (12/24) of newly diagnosed patients had a positive enterovirus RT-PCR, however, control children were negative ($p < 0.001$). With group B primers, enterovirus sequences were detected in 46% (11/24) of newly diagnosed patients, and in 29% (7/24) of control children, but the difference was not statistically significant. Taking into account the results obtained with the two sets of primers, the detection of enterovirus RNA was positive in 75% (18/24) of newly diagnosed patients and only in 29% (7/24) of control children.

One hundred and twelve diabetic children and 56 healthy controls have been included in an Italian study [154]. Enterovirus common capsid antigens were detected by immunofluorescence in a panel of cell lines inoculated with total leucocytes from peripheral blood, and enteroviral RNA was detected in these cultures as well. Enteroviruses were detected by RT-PCR in 93/112 case children (83%) and 4/56 control children (7%), and directly in leukocytes at lower frequency. Thirteen cases of familial enterovirus infection were observed.

Enteroviral RNA has been searched in PBMC, plasma, throat and stools of 10 newly diagnosed children and 20 control children [132]. Viral RNA was found in PBMC of 4 patients (40%), in plasma of 2 patients (20%), and in stools in 1 patient, in contrast, no sample was positive in control children. All throat swabs from patients and controls were negative. According to the authors, a prolonged enteroviral infection could be suspected in these patients in front of a positive detection of viral RNA in PBMC and/or plasma together with a negative detection of viral RNA in stool and throat swabs.

4.1.4. *Pancreas*

A 10 years old child with a flu-like illness within 3 days prior to admission in hospital for diabetic ketoacidosis died on the 7th day of admission [175]. The autopsy showed infiltration of the pancreas islets by lymphocytes with necrosis of beta cells. The inoculation of mouse, monkey and human cell cultures with a homogenate of the patient's pancreas had led to the isolation of a CVB4. Serology showed an 8 fold increase in titer of neutralizing antibody to this virus between the second hospital day and day of death. Inoculation of mice with this viral isolate led to hyperglycemia, inflammation of the islets of Langerhans and necrosis of beta cells. Immunofluorescence detected viral antigen in beta cells of mouse pancreatic section. The virus isolate obtained from this patient is known as CVB4 E2.

A few years later, a British group [52], did not find VP1 by immunohistochemistry in pancreas beta cells of 88 patients who had died at clinical presentation of T1D. In contrast, by

using the same method VP1 protein was found in cardiac myocytes from 12 of the 20 patients whose cause of death was an acute coxsackievirus B myocarditis, and in seven of these positive cases, insulinitis was observed and VP1 was detected in islet endocrine cells, but rarely in exocrine pancreas. Together, these data suggested that the beta cell destruction in patients with fatal diabetes was unlikely related to a direct cytopathic effect of coxsackievirus B, however the role of viruses in the destruction of beta cells through an autoimmune mechanism can not be excluded.

A few years later, another group investigated the presence of enteroviral RNA in the pancreas of 2 children patients with fatal acute-onset T1D and 5 controls by using RT-PCR and Southern blot hybridization [17]. The detection of Enteroviral RNA, and other viral genome (cytomegalovirus, mumps and rubella) was negative in every case.

The relationship between enterovirus and T1D and the type of pancreatic cells infected with enteroviruses has been investigated by a Finnish group [172]. The study included 12 newborn infants who died of fulminant infection with enteroviruses (myocarditis in most cases). Autopsy pancreases from 65 patients with T1D and 40 control subjects matched for age and sex were also studied for presence of enteroviral RNA by in situ hybridisation. Enteroviral RNA was detected in pancreas of 58% (7/12) of the 12 newborns; the enterovirus-positive cells were detected in numerous pancreatic islets and in some duct cells but not in exocrine pancreas. In situ hybridisation identified enteroviruses in 6% (4/65) of diabetic patients. Enteroviral RNA was located exclusively in islets. None of the control subjects was positive for enteroviral RNA.

More recently, an Italian team studied the relationship between enterovirus infection, inflammation of pancreatic beta cells, autoimmunity and beta cell function [43]. Six newly diagnosed T1D patients (1 week to 9 months) and 26 control organ donors were included in this study. Immunohistochemistry, electron microscopy, RT-PCR and sequencing, and virus isolation in cell culture were used to detect enteroviruses in pancreatic autopsic tissue. Enteroviral RNA was detected in 3 out of 6 diabetic patients but not in controls. Infection was specific of beta cells with non-destructive insulinitis and with natural killer cell infiltration. There was not apparent reduction of islet beta cells in these patients. The virus isolated from one of these 3 patients, identified as CVB4 was able to infect human pancreatic beta cells of nondiabetic multiorgan donors. Viral inclusions and signs of pyknosis were observed by electronic microscopy, and a loss of beta cell function was assessed by insulin secretion response to glucose, arginine and glibenclamide. These data show that enterovirus could infect beta cells in patients with T1D and that these viruses could be responsible for inflammation and functional abnormalities of these cells.

Recently, authors raised the issue of the relevance of pancreas tissue samples to display the relationship between enterovirus infection and type 1 diabetes, since no enteroviral RNA was detected by RT-PCR in samples from pancreatic organ donors with diabetes [158]. Further investigation with pancreas from additional donors are needed to address the issue of the persistence of enteroviruses in this organ. Whether enteroviruses are present in pancreas tissue at the time of symptom onset should be investigated but tissue samples can not be easily obtained by biopsy in the case of this organ.

The prevalence of enteroviral capsid protein (VP1) in pancreatic autopsy tissue from 72 newly diagnosed T1D children and a large cohort of controls has been studied by immunohistochemical staining by a british group [122]. The cell subtypes infected with enteroviruses were identified by immunofluorescence. The criterion of positivity was the presence of at least one intensely stained endocrine cell in an islet within any given section. According to this criterion, 61% (44/72) of diabetic children were positive in immunohistochemistry versus 7.7% (3/39) of control children ($p < 0.001$). There was no significant difference regarding age or gender between the VP1-positive and VP1-negative groups however the duration of diabetes seemed to be lower in the VP1-positive group (2.32 months vs 16.5 months; $p=0.06$).

4.1.5. Stools

Enteroviruses are present in stools of infected individuals [125]. The hypothesis of the role of enteroviruses in T1D prompted researchers to look for these viruses in stools of patients.

An Italian group investigated enteroviruses in stools from 43 newly diagnosed diabetic children and 22 control children [42]. Stools and serum samples were collected within 2 months from the beginning of diabetes symptoms. In order to isolate enterovirus, stools were inoculated to cell cultures and in suckling mice. Neutralizing antibodies to coxsackie virus B4 and anti-coxsackie viruses B1 to B6 complement fixing antibodies were measured. There was one case with high antibodies against coxsackie B4 virus but no enterovirus was isolated from stools.

A 16 month-old child with a predisposing HLA group (B18 DRw3) developed diabetes [21]. The disease outcame at hospital on the third day of steroid therapy for febrile purpura within the week of diphtheria/pertussis/tetanus and polio vaccination. Coxsackievirus B5 was isolated from stools and serologic studies showed a rise in titer of neutralizing antibodies directed to that isolate from less than 10 on the first day to 640 on the eleventh day. The sudden onset of T1D in the course an acute coxsackievirus B5 infection suggests the potential involvement of this virus in the disease in that case.

4.1.6. Intestine

Different virological methods were used in a Finnish study to evaluate whether enteroviruses can be found in small intestinal mucosa of 12 patients with T1D (age: 18 to 53, 2 out of them were male) and 10 non-diabetic subjects (age 23 to 71, 3 out of them were male) [114]. These individuals underwent gastroscopy for gastrointestinal symptoms and intestinal mucosa biopsies were taken for morphological analysis, which did not reveal any abnormality. To analyse the presence of enteroviruses in intestinal biopsy samples, immunohistochemistry was used for detecting the viral protein VP1, and in situ hybridization. RT-PCR were used for detecting viral RNA. Six out of 12 (50%) diabetic patients were positive for enteroviral RNA by in situ hybridization, whereas all control subjects were negative ($p = 0.015$). Two of these positive patients had enteroviral RNA in the cells of lamina propria; four were positive in the epithelial cells of villi, in the crypts and in the cells of lamina propria. Immunohistochemistry was positive in 9 out of 12 (75%) of diabetic patients but only in 10% (1/10) of control subjects ($p = 0.004$): the protein VP1 was mainly localized in the epithelium. Viral RNA was found by RT-PCR in a frozen sample from one of the 4 diabetic patients who were

positive in both in situ hybridization and immunohistochemistry. There was no relationship between the detection of enteroviral RNA in gut mucosa of diabetic patients and duration of diabetes, gender, HLA type or hyperglycemia.

The discrepancy in results obtained by RT-PCR and in situ hybridization could be explained by the fact that intestinal biopsy samples were obtained from two sites of the intestine, and by differences in samples preparation. These results display that subjects with T1D have enteroviral components in their gut mucosa.

4.2. Enterovirus in biological samples from individuals at high-risk of diabetes

A Finnish prospective study concerned children with prediabetic state, which were derived from a previous study "Childhood Diabetes in Finland" (DiMe) [99]. The study investigated enterovirus RNA in 93 serum samples from 11 prediabetic children who progressed to T1D during the follow-up. One hundred and eight serum samples from 34 control children who participated in the same cohort but did not develop autoimmunity against beta cells or T1D were examined. In this study, serum samples from 47 children with newly diagnosed T1D were also analysed. Antibodies against islet cells (ICA), glutamic acid decarboxylase (GADA), insulin (IAA) and the protein tyrosine phosphatase-related IA-2 protein (IA2-A) were analysed. Antibodies against coxsackie viruses B1 to B6 were measured by neutralization assay. Enterovirus RNA was found in 12 % (11/93) of follow-up samples from prediabetic children compared to only 2% (2/108) of follow-up samples from matched controls ($p < 0.01$). Viral RNA was detected in none (0/47) of the serum samples obtained from diabetic children. The presence of enteroviral RNA was associated with a concomitant increase in ICA ($p < 0.01$) and GADA ($p < 0.05$), whereas no increase was observed in the rates of IAA and IA-2A. This study suggests that enterovirus genome can be found in serum of individuals and that it is associated with the induction of autoimmunity several years before the onset of symptoms. The presence of enterovirus RNA in serum of prediabetic children has been studied in Cuba [127]. This study encompassed 32 children positive for antibodies against ICA having a first-degree relative with T1D, 31 children, negative for antibodies against ICA having a diabetic first-degree relative, and 194 controls, who were matched for age, gender, geographic origin and date of serum collection. Enterovirus RNA was found in 15.6% (5/32) of islet autoantibody-positive first-degree relatives children, whereas all controls were negative for enteroviral genome ($P = 0.003$). Enterovirus RNA was found in 3.2% of 31 children, negative for antibodies against ICA having a diabetic first-degree relative, and in 1.6% of controls.

After seroconversion for islet antibodies (against GAD, insulin, IA-2), serum and rectal swabs were collected every 3-6 months until diagnosis of diabetes in the Diabetes and Autoimmunity Study in the Young (DAISY) encompassing 2,365 american genetically predisposed children for islet autoimmunity and T1D, according to HLA, and siblings or offspring of people with T1D (regardless of their genotype) [141]. Fifty of the 140 children who seroconverted to positivity for islet autoantibodies progressed to T1D. The prevalence of enteroviral RNA in serum and rectal swabs as displayed by RT-PCR declined with age and seemed to be higher at visits positive for multiple islet autoantibodies. The risk of progres-

sion to T1D following detection of enteroviral RNA in serum, in a 4-month interval, was significantly increased compared with negative detection. In contrast, the presence of enteroviral RNA in rectal swabs did not predict progression to T1D, which is in agreement with the results of the MIDIA study including 911 Norwegian children identified at birth with a HLA genotype conferring a risk of T1D [149].

Thirty height children with an increased genetic susceptibility to diabetes followed-up from birth who have progressed to T1D and 140 control children matched for sexe, date of birth, hospital district and HLA-DQ-conferred genetic susceptibility to T1D were included in the finnish type 1 Diabetes Prediction and Prevention study (DiPP) [115]. Serum samples were analysed for enterovirus RNA by RT-PCR: 5.1% of samples were enterovirus RNA positive in case children but only 1, 9% in control children ($p < 0.01$). In boys, the detection of enterovirus RNA during the 6 months preceding the discovery of autoantibodies was associated with a risk of diabetes ($p < 0.01$).

| Biological samples | Number of Cases/ Controls | Children/ adults patients | Positives cases/ Controls p value | Methods of detection | Reference | country |
|--------------------|---------------------------|---------------------------|---|----------------------|--------------------------|-----------|
| Whole blood | 24/27 | 0/24 | 6/0 $p < 0.01$ | RT-PCR | Andréoletti et al., 1997 | France |
| Whole blood | 56/37 | 25/31 | 21/0 p^* | RT-PCR | Chehadeh et al., 2000 | France |
| Woole Blood | 600/600 | 600/0 | 27/14 $p=0.04$ | RT-PCR | Dahlquist et al., 2004 | Sweden |
| Serum | 14/45 | 14/0 | 9/2 p^* | RT-PCR | Clements et al., 1995 | England |
| Serum | 110/182 | 110/0 | 30/9 $p < 0.005$ | RT-PCR | Nairn et al., 1999 | England |
| Serum | 16/49 | 16/0 | 2/1 $p > 0.05$ | RT-PCR | Coutant et al., 2002 | France |
| Serum | 70/30 | 70/0 | 26/0 $p < 0.05$ | Cell culture | Maha et al., 2003 | Egypt |
| Serum | 61/58 | NI | 23/2 $p < 0.05$ | RT-PCR | Kawashima et al., 2004 | Japan |
| Serum | 47/50 | 47/0 | 17/2 $p < 0.001$ | RT-PCR | Moya-Suri et al., 2005 | Germany |
| Serum | 34/68 | 34/0 | 9/2 $p=0.0007$ | RT-PCR | Sarmiento et al., 2007 | Cuba |
| Plasma stools | 206/160 | 206/0 | 62/6 plasma or stools $p < 0.001$ | RT-PCR | Craig et al., 2003 | Australia |

| Biological samples | Number of Cases/ Controls | Children/ adults patients | Positives cases/ Controls p value | Methods of detection | Reference | country |
|--------------------|---------------------------|---------------------------|--------------------------------------|--|-------------------------|-------------|
| PBMC | 24/24 | 24/0 | 18/7 p* | RT-PCR | Yin et al., 2002 | Sweden |
| leucocytes | 112/56 | 112/0 | 93/4 p* | RT-PCR | Toniolo et al., 2010 | Italy |
| PBMC | 10/20 | 10/0 | 4/0 p>0.05 | RT-PCR | Schulte et al., 2010 | Netherlands |
| plasma | 10/20 | | 2/0 | | | |
| stools | 10/20 | | 1/0 | | | |
| throat | 10/20 | | 0/0 | | | |
| Pancreas | 149/21 | NI | 0/7 p* | IHC | Foulis et al., 1990 | England |
| Pancreas | 65/40 | 0/65 | 4/0 p* | HIS | Ylipaasto et al., 2004 | Finland |
| Pancreas | 6/26 | 2/4 | 3/0 | IHC Electronic microscope Cell culture RT-PCR | Dotta et al., 2007 | Italy |
| Pancreas | 72/39 | NI | 44/3 p<0.001 | IHC | Richardson et al., 2009 | England |
| Intestine | 12/10 | 0/12 | 6/0 p=0.015 9/1 p=0.004 | HIS IHC | Oikarinen et al., 2007 | Finland |

Table 3. Detection of enterovirus and/or their components (RNA, proteins) in biological samples of patients with type 1 diabetes. PBMC: Peripheral Blood Mononuclear Cells, RT-PCR: Retrotranscription Polymerase Chain Reaction, IHC: Immunohistochemistry, HIS: Hybridization in situ, NI: Not Indicated, p*: p value not mentioned.

5. Enterovirus and type 1 diabetes: Experimental approach

In previous sections of this review, clinical studies that were conducted to assess the relationship between enteroviruses and T1D have been presented. A significant association between enterovirus infection and T1D, particularly for studies that used molecular methods, has been displayed, and when identified the most often involved enteroviruses were coxsackieviruses B. Experimental studies have been performed to understand the possible link between enterovirus and T1D. In the present section, the results of in vivo studies on one hand and those of in vitro studies on the other hand are presented and analyzed.

5.1. In vivo studies in animal models

In order to analyse the hypothesis that enterovirus infections enhance or elicit autoimmune disorders such as T1D, a significant body of evidence is derived from investigations using animal models. Most of them used to explore research hypotheses regarding the relationship between enteroviruses and type 1 diabetes are mouse models (NOD, C57BL/k, C57BL/6, SJL/J, DBA/2, SWR/J, BALB/c, B10, CD-1...) [83]. Despite their limitation in diseases investigations, experimental models have greatly contributed to our knowledge of human diseases. The predominance of murine models for the investigation of the relationship between enteroviruses and T1D is due, among others, to a physiology relatively similar to that of human beings and the presence of specific receptors, the more prominent of them could be the coxsackievirus and adenovirus receptor (CAR) which is a receptor for coxsackievirus B [86]. Therefore experimental datas have been obtained from models based on infection with coxsackievirus B (CVB) (figure 3).

5.1.1. Enterovirus and immune system

Experimental in vivo studies have contributed improving our understanding of genetic and immunological implications, enteroviral tropism and mechanisms of pancreatic β -cells destruction in the context of enteroviral infection [83]. Enteroviruses generally infect the exocrine pancreas, but some strains preferentially infect islets. Some studies have addressed the role of CAR, the main receptor for CVB entry into host cell, in enteroviral tropism and target organ infection. CAR is expressed by intestine, pancreas and heart epithelial cells, as well as cardiomyocytes [54]. In transgenic mice CVB3 titers were markedly reduced in CAR-deficient tissues and pancreatic CAR deletion induced a strong attenuation of pancreatic CVB3 infection and pancreatitis [86].

The development of innate and adaptive immune responses is mediated by type I interferons (IFNs) produced early during viral infection to induce an antiviral state within target cells. Experimental studies have shown that mice deficient in type I IFNs receptor are more susceptible and die more rapidly than controls when infected with CVB3 [169, 40]. An efficient immune response depends on rapid recognition of viruses by the innate immune system and this recognition is primarily achieved by pattern-recognition receptors such as toll-like receptors (TLRs), retinoid-inducible gene 1-like receptors (RIG-1) and NOD-like receptors. It is noteworthy that interactions between NOD-like receptors and enteroviruses are still poorly understood.

Toll-like receptors are transmembrane glycoproteins expressed on the cytoplasmic membrane or in intracellular vesicals of several immune and non-immune cell populations; while RIG-I-like receptors, represented by RIG-I and the interferon-induced with helicase C domain 1 (IFIH-1), also called melanoma differentiation-associated gene 5 (MDA5) are expressed in the cytosol of most cell types [91]. Among TLRs, TLR3, known to be double-stranded RNA sensor on monocytes, is known to be crucial for the survival of mice infected with CVB4 [123]; and the production of cytokines by murine plasmacytoid dendritic cells have been shown to be closely linked with CVB detection and recognition by TLR7 [168]. The MDA5 is in turn essential for type I IFNs responses to CVB, since MDA5 knockout mice

are deficient to type I IFN and are prone to early death when infected with CVB (Wang et al., 2010). Thus, pattern-recognition receptors activation by enteroviruses results on IFNs and chemokines production which could lead to an inflammatory state in infected tissues. Moreover, these inflammatory factors enhance the overexpression of MHC-I molecules, which could result in an increased exposure of infected cells to the immune system and could initiate an autoimmune process that could directly contribute to islet cells damage [173]. However an activation of MDA-5 with any other factor can not initiate autoimmunity, whereas IFN-I-induced MDA-5 accelerated a preexistent autoimmune process in an animal model [38].

Some studies in animals have highlighted the potent role of antibodies and immune cells during enteroviral infection. Results on mice have shown that gammaglobulins are essential in limiting the scope and severity of enteroviral infection by preventing viral persistence in infected tissues [103] and T lymphocytes can deeply limit virus replication in CVB3-induced myocarditis and pancreatitis [63].

5.1.2. Enteroviruses can induce diabetes in mice

Experiments have been conducted to evaluate the ability of CVB4 to elicit diabetes in mice. These studies have shown that the pancreas was a predominant site of virus replication and the target of a strong immune response.

A CVB4 strain isolated by Yoon et al. from the pancreas of a 10-year-old boy who died of diabetic ketoacidosis and called CVB4E2, have induced hyperglycaemia with inflammation of the Langerhans islets and β -cell necrosis when inoculated to susceptible mice SJL/J [175]. A similar result was obtain in the same SJL/J mice strain when inoculated with a CVB5 strain isolated from stools of a diabetic patient [121]. In another study, CVB4E2 has led to hyperglycaemia and the appearance of anti-GAD antibodies in the vast majority of mice, suggesting a potent role of enteroviruses in initiating or accelerating autoimmunity against β -cells [57]. Diabetes with viral replication in β -cells has been also obtained when CVB4 JVB strain was inoculated to susceptible mice [174]. In addition, diabetes has been obtained in mice infected by CVB3 and CVB5 when animals were first treated with sub-diabetogenic doses of streptozotocin, a highly specific β -cell toxin. Findings from that study have revealed that virus-induced diabetes can be facilitated by cumulative effects induced by genetic factors or environmental insults (chemicals, drugs, toxins), since CVB strains (B3 and B5) used in that study ordinarily produce little if any β -cell damage [153]. Furthermore, CVB4-induced abnormal thymic, splenic and peripheral lymphocytes repertoire maturation has been described in mice and these lymphocyte maturation disorders have preceded the onset of hyperglycemia in animals [22].

In a study, CD-1 mice have been infected with the diabetogenic strain CVB4E2 and followed during one year. Results from this study have revealed a prolonged presence of viral RNA in pancreas tissue, a significant decrease in insulin levels and islets cells destruction by two mechanisms: directly by cytotoxic effects of IFN- γ -stimulated peritoneal macrophages and by an antibody-dependent mechanism through islet cell autoantibody (ICA) [133]. In another study, infection of mice with CVB4 has led to a rapid development of the disease mediat-

ed by bystander activation of T cells [73], which would tend to confirm early findings that have shown that infection of normal mice with CVB4 causes an overt diabetes associated with low insulin levels consistent with islet cells destruction [33].

The mechanism behind this β -cell destruction has been explored in some studies. Analysis of the results from these studies reveals that the spontaneous development of diabetes in NOD mice can be accelerated by CVB4 infection though a “bystander” effect only if a sufficient number of pre-existing autoreactive T-cells was already present [134]. This observation was in agreement with another study which has shown that the overexpression of a TCR transgene specific to an islet autoantigen has induced diabetes onset 2-4 weeks after CVB4 inoculation in mice that do not develop diabetes spontaneously [73]. Islet cell destruction by autoreactive T-cells was the result of the release of sequestered islet antigens which followed β -cell inflammation and destruction caused by CVB infection [73, 2001]. Other studies have stated that β -cells are phagocytosed by antigen-presenting cells like macrophages, rather than directly destroyed by a CVB-induced process [75, 133], because antigen-presenting cells isolated from CVB4-infected mice can induce diabetes if inoculated to non-infected mice [75].

Among T1D animal models, the NOD mouse remains far the most used and studied model. The NOD mice are susceptible to spontaneous T1D that develops over several weeks and share most aspects of human T1D [83]. In NOD mice, the disease occurs after T-cell-mediated destruction of β -cells [87, 170]. Some studies have revealed that CVB infection effects in NOD mice appear to be contingent upon the precise moment at which infection occurs [134, 156]. Thus, rapid T1D induction can be obtained when older NOD mice are inoculated with CVB and the disease occurs much more rapidly when mice islets are already developing autoimmune insulinitis and high islet cells lytic viral replication are observed when a virulent strain is inoculated [156]. These findings suggest that CVB replicate more readily in aged NOD mice islet cells, especially if there is inflammation, than in those of younger animals.

Another factor seems to be the magnitude of effects of CVB4 infection onto β -cells, depending on the permissiveness of target cells, which is closely related to their sensitivity to IFNs. Indeed, coxsackievirus B4-infected-NOD mice which had defective IFNs responses have developed an acute form of type 1 diabetes, similar to the one in humans following severe enteroviral infection. Interferons act by inducing an antiviral state in target cells, including pancreatic β -cells, by reducing their permissiveness to viral entry and replication. The effect of IFNs is transmitted as an intracellular signal through the Jack-STAT signaling pathway [140]. In transgenic NOD mice that express the suppressor of cytokine signaling 1 (SOCS-1), a negative regulator of IFN action which inhibits the Jack-STAT signaling pathway, CVB4 infection has resulted in β -cell loss and diabetes onset. Similar results have been obtained during the same study in transgenic NOD mice of which β -cells were lacking IFN receptors. In addition to inducing on β -cells a lower permissiveness to CVB4 infection, IFNs contributed also to deeply decrease their sensitivity to NK cell-mediated destruction [50].

5.1.3. Molecular mimicry hypothesis

Glutamic acid decarboxylase 65kD (GAD65), a candidate autoantigen in the pathogenesis of T1D, is expressed in pancreatic β -cells. Some findings from mice have shown that CTL (cyto-

toxic T lymphocytes) are cytotoxic to islet cells [44] and that T cell responses to GAD65 were detectable in prediabetic NOD mice spleens prior to disease onset [89, 152]. One of the mechanisms proposed to explain enterovirus-induced autoimmunity in T1D model is based on the cross-reactivity between CVB antigens and β -cell endogenous proteins through molecular mimicry. Pancreatic β -cells infection by CVB will be followed by inflammatory response resulting in β -cell destruction and increased self-antigen presentation due to their phagocytosis by antigen-presenting cells (APCs). Since P2-C protein sequence of CVB partially resembles that of human GAD65, both autoreactive and antiviral T-cells activated upon CVB infection, might act as strong enhancers that may accelerate or aggravate the ongoing autoimmune process [28, 151].

Regardless T-cells cross reactivity effects, experiments on CVB4-infected NOD mice have provided the evidence that the release of β -cell antigens followed by their presentation by APCs (antigen presentation cells) such as macrophages can initiate or promote β -cell autoimmunity [75].

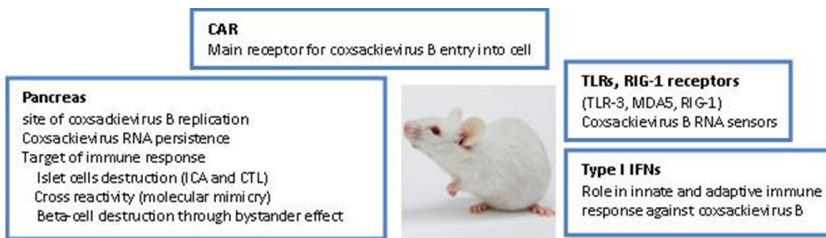

Figure 3. Information brought by animal models regarding coxsackievirus B infection and some aspects of type 1 diabetes pathogenesis

5.2. In vitro infection of β -cells and other cells with enteroviruses

Experiments have been conducted in vitro in order to analyse the hypotheses in favour of an association between enterovirus infections and T1D. Whether enteroviruses were able to infect the pancreatic tissue is a key issue concerning the relationship between enteroviruses and T1D. It has been shown that enteroviruses may be involved in the pathogenesis of T1D, either through direct β -cell infection or as triggers of the autoimmune processes. In particular, some results from in vitro experiments have suggested that enteroviruses, and especially CVB, may infect human β -cells and the infection may result in no apparent immediate effect or in functional impairment of β -cell [175, 174, 167, 124]. Most common enteroviruses in the environment can infect cultured human islets with β -cell destruction [93]. The figure 4 summarizes information brought by in vitro studies regarding coxsackievirus B infection which can be relevant for type 1 diabetes pathogenesis.

5.2.1. Enterovirus infection of β -cells

Persistent infection of human pancreatic islets by CVB associated with alpha interferon (IFN) synthesis was observed [23]. In this study conducted by our team, human pancreatic islets obtained from adult brain-dead donors and cultured in noncoated membrane inserts were infected with CVB3 and a diabetogenic (CVB4 E2) and a non-diabetogenic (CVB4 JVB) strain of CVB4. It was displayed that both α and β cells in human pancreatic islet can be persistently infected and long term CVB replication has been observed through the presence of infectious particles in culture supernatant fluids and intracellular viral negative-strand RNA up to 30 days post infection. This study showed that human islets challenged with CVB can synthesize IFN- α which is produced by infected β -cells only. These data support the hypothesis of a role of CVB in the high levels of type I IFNs that have been detected in pancreas or islets of patients with T1D [51, 76]. The viral persistence accompanied by synthesis of IFN- α can enhance autoimmune processes leading to diabetes onset. The possibility that IFN- α could take part in T1D onset in genetically predisposed host have been tested in transgenic mice of which β -cells express this cytokine. It revealed that IFN- α was able to provoke the onset of the disease in transgenic animals, and that neutralizing IFN- α prevented inflammation and diabetes [142]. The expression of IFN- α in β -cells may lead to the development of diabetes in transgenic mice through the activation of autoimmune (islet-reactive) CD4+ TH1 cells [20].

Recent findings have shown that type I IFNs production can be induced in CVB infected human islet cells by intracellular viral RNA sensors such as TLR3, MDA-5 and RIG-1 genes [77]. These pattern-recognition receptors have also been told to upregulate the synthesis and production of chemokines. The sustaining of this process - IFNs and chemokines production - could be deleterious and involved in the development of autoimmunity, especially since persistent infection of islets cells in vitro by some CVB strains has been reported [23].

The infection of β -cells with CVB and the molecular pathways leading to CVB-induced β -cell death have been investigated. One study was aimed to evaluate the effects of different CVB4 strains on islets morphology and insulin release and another one compared inflammatory-related genes expression in CVB4-infected and uninfected isolated human islets. Results from these studies have revealed that even though the outcome of the infection differed, islet cells can be infected by all CVB4 strains. However, significant differences in viral titers and cell morphology were observed according to the phenotype of the strain: one with no cytopathic effect despite high virus titres (VD2921 stain), and the other with a pronounced cytopathic effect (V89-4557 strain), whereas a third one (JVB strain) have induced a significant increase of insulin release [55]. A microarray analysis of RNA from CVB4-infected human islets have shown specific induction of several inflammatory genes, some of them encoding proteins with potent biological activity such as IL-1 β , IL-6, IL-8, MCP-1 and RANTES [117]. Recently, it has been reported that, except CVB1 and CVB3, all other CVB viruses induced a dose-dependent production of pro-inflammatory cytokines and chemokines in a rat insulinoma β -cell line (INS-1) [107].

The release of proinflammatory cytokines may strongly contribute to maintain a local pancreatic-islet inflammation that could result in an amplification of the immune attack against

β -cells. In addition, the activation of MHC molecules in human fetal islet cells cultures infected by CVB4 could result in an increase exposure of infected cells to the immune system and support the autoimmune response against β -cells [119].

The inflammation of β -cells is supposed to be an early event in the pathogenesis of type 1 diabetes [45]. An exaggerated inflammatory response to enterovirus may contribute to induce a prolonged inflammation state and β -cell loss, and could initiate or aggravate pathogenic processes of type 1 diabetes.

5.2.2. Enterovirus infection of thymus

It has been shown in mouse that CVB could infect the thymus with a disruption of organ functions that was associated with diabetes [22]. Further studies have been conducted to investigate the mechanisms and consequences of infection of thymus with CVB. The establishment of central T-cell tolerance is ensured by the thymus. Thymic epithelial cells (TEC) participate actively in the development of a biochemical environment needed for the maturation of immunocompetent T cells. Thymic epithelial cells are actively involved in the promotion of T-cell maturation by mediating negative and positive selection of thymocytes and by participating to the induction of tolerance [136].

In collaboration with Pr Vincent Geenen and his team (University of Liège, Belgium) we investigated the hypothesis that T1D which is an autoimmune disease, can result from the disturbance of the central tolerance. Due to the role of thymus in induction and establishment of self-tolerance, enteroviral infection of TEC may result in interference and disturbance of T-cell ontogeny, which can induce or enhance the immune process leading to T1D. The infection of human TEC primary cultures with CVB4 and the resulting consequences on TEC function have been studied. Human TEC, isolated from thymus fragments obtained from children undergoing corrective surgery, were infected with CVB4 JVB and E2 strains. Findings from this study have revealed that a cytolytic virus such as CVB4 can infect persistently human TEC cultures without obvious cytopathic effect and this infection have led to a continuous increased production of cytokines IL-6, GM-CSF and LIF [14]. In order to evaluate the effect of enterovirus infection onto fetal thymus during pregnancy, intact explanted human foetal thymic organ cultures were infected with CVB4E2 strain. Results from this study have shown progressive thymocyte depletion and upregulation of MHC-I molecules expression on CD4+CD8+ double positive cells [15]. Another study was conducted on mouse to assess the effect of CVB infection on thymocytes maturation and differentiation. In this study, whole foetal thymus organ cultures obtained from 14 days foetal CD-1 mice were infected with CVB4E2 strain. Findings from that study have revealed in infected culture a disturbance of maturation and differentiation of T cells characterized by increased levels of mature CD4+ and CD8+ cells associated with decreased percentage of double positive cells [16].

Furthermore it was reported that CVB4 RNA can be found in thymus up to 70 days after per os infection of mice with CVB4E2. In vitro, CVB4 was able to infect and replicate in primary cultures of adult murine splenic and thymic cells [81].

The ability of enteroviruses such as CVB4 to infect the thymus during fetal life could have deleterious effects on thymus functions, since neonatal exposure to thymotropic virus could

induce a virus-specific nonresponsiveness [95]. A global analysis of all these findings suggests that thymus organ can be infected by coxsackievirus B which can disturb the organ function with possible effects on the autoimmune processes leading to T1D.

5.2.3. *Antibody-dependent enhancement of enterovirus infection*

The antibody-dependent enhancement (ADE) of infection is a mechanism observed in vitro with various viruses and which can intervene in pathogenic processes induced by these viruses [145]. The ADE of CVB4 infection has been discovered by our group. It is caused by enhancing antibodies devoid of neutralizing activity and has been found in serum /plasma of T1D patients and controls. These antibodies, isolated from plasma by affinity chromatography, increase the CVB4-induced synthesis of IFN- α by human peripheral blood mononuclear cells (PBMC) in vitro [25]. It has been demonstrated that IFN- α synthesis by PBMC infected with CVB4 preably incubated with specific antibodies is a result of the infection of monocytes that occurs by a mechanism involving the receptors CAR and those for the Fc portion of IgG molecule, Fc γ RII (Fc γ receptor II) and Fc γ RIII localised at the cell surface membrane [66]. CVB4 can strongly induce the production of IFN- α by PBMCs from patients with T1D compared with PBMC from healthy controls, which is due to anti-CVB4 enhancing antibodies bound to the cell surface membrane. In addition, a higher level of IFN- α was produced by PBMC of patients inoculated with CVB4 preably incubated with plasma of patients [67]. The target of these antibodies has been identified as the enteroviral protein VP4 and it has been shown that the prevalence and the titres of anti-VP4 antibodies were higher in patients with T1D than in control subjects [26]. Specific anti-VP4 antibodies enhance the infection of PBMC with CVB4 [129]. The sequence of VP4 recognized by these antibodies was investigated and identified in competition experiments as amino acids 11 to 30 by using synthetic overlapping peptides spanning CVB4E2 VP4 protein [130]. The VP4 protein and a VP4 peptide have been used to detect anti-CVB4 enhancing antibodies by ELISA [26, 130]. The fact that enhancing anti-CVB4 antibodies bind the viral particles through VP4 is challenging, since, according the structural analysis of frozen enteroviruses by X-ray diffraction, the capsid protein VP4 is localized along the inner virion surface, like the amino-terminal sequences of the three external proteins VP1, VP2 and VP3. The explanation lies in the dynamic character of the virus structure at 37°C that would allow an exposure of these normally internal sequences and making a piece of the VP4 protein accessible to antibodies, as it has been shown in the case of the amino-terminal part of VP1 in the poliovirus system [96].

The increased infection of monocytes with CVB4 due to enhancing antibodies could lead, in vivo, in dissemination and worsening of histological lesions that may contribute to CVB4-induced disease, as described in a model of CVB3-induced myocarditis [131, 58, 92]. Furthermore, the enterovirus -induced production of IFN- α enhanced by antibodies, can play a pathogenic role. Indeed, chronic IFN- α synthesis or its abnormal activation in response to recurrent or repeated enteroviral infections can be associated with disorders leading to autoimmune diseases [23].

Further studies are needed to investigate the role of enhancing antibodies in the CVB-induced pathogenesis of T1D.

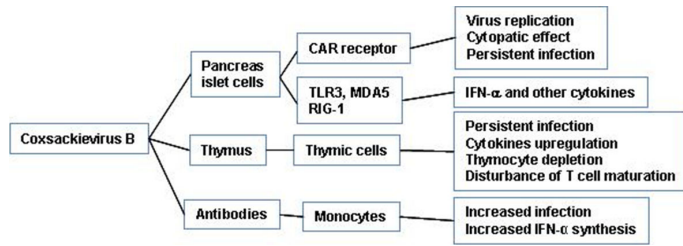

Figure 4. Information brought by in vitro studies regarding coxsackievirus B infection

5.3. Complex relationship between enteroviruses and type 1 diabetes

As mentioned above, the role of enteroviruses in T1D disease is strongly suspected. In contrast, a protective role of enteroviruses is suggested as well. Experimental data in favour of a protective role of these viruses have been reported. Indeed, some studies have shown that, rather than triggering an autoimmune process, CVB infections can provide significant protection against the development of T1D [155, 48]. Cocksackievirus B4, the human enterovirus most associated with an etiologic role in human T1D, has been reported to increase the rate of diabetes onset in older NOD mice but not in younger mice [134]. This result has been confirmed by other groups who provided evidence that disease induction required a pre-existing accumulation of β -cell specific autoreactive T cells within the pancreas, a phenomenon observed in older NOD mice, but not in younger mice [74, 156]. This protective effect may involve the virus strain, its virulence and replication rate, as well as the stage of autoimmune development, and the mechanism relies in long-term tolerance due to an increase in protective regulatory T cells with TGF- β production [49].

These findings support the concept that virus infections occurring early in childhood had a protective effect against T1D and are in agreement with the hygiene hypothesis [7, 157]. Indeed, it should be emphasized that there are significantly more enterovirus infections annually than new cases of T1D in population. The decreased enterovirus exposure rates following the increased hygiene levels might explain the high risk of developing the disease, since it has been revealed in epidemiological studies that T1D incidence is higher in developed countries than in developing ones, from less than 1 per 100,000 inhabitants in Asia to 14 in US and even more than 30 per 100,000 in Scandinavia [139].

6. Conclusion

Type 1 diabetes is a complex multifactorial disease. The involvement of enteroviruses as a major non-genetic etiological factor is a topic of reflexion for several research teams worldwide. Studies from these teams have shown that enteroviral infections, especially coxsackievirus B infections, are closely linked with T1D. Findings from experimental in vitro and in vivo studies have lightened the potent role that can play enteroviruses in inducing and/or worsening the disease. However, in certain particular conditions, enteroviruses can induce a

protective effect in mouse model. Therefore, further studies are needed to understand the mechanisms behind this complex relationship between enteroviruses and T1D.

Declaration of interest

No conflict of interest

Acknowledgements

The authors thank Delphine Caloone for technical assistance and all their collaborators. The studies performed by the authors or in progress have been or are supported by EU FP5 VIR-DIAB Project (Contract QLK 2-CT-2001-01910), EU FP6 Integrated Project EURO-THY-MAIDE, (Contract LSHB-CT-2003-503410), EU FP7 PEVNET Project (FP7-HEALTH-2010-single-stage N° 261441), grants from Nord-Pas-de-Calais Région (ArCir convention 2004/018; BBS 2006), CHRU Lille, the ministère de l'Éducation nationale de la recherche et de la technologie, Université de Lille 2, France, and the comité mixte de coopération universitaire franco-tunisienne (CMCU 2004 N° 04/G0810 and CMCU 2008N808/G0808). Didier Hober was Fondation pour la Recherche Médicale 2008 prize winner. Didier Hober is a member of the Virus in Diabetes International Study group (VIDIS group).

Author details

Didier Hober^{1*}, Famara Sané¹, Karena Riedweg¹, Ilham Mounna¹, Anne Goffard¹, Laura Choteau¹, Enagnon Kazali Alidjinou¹ and Rachel Desaillood²

*Address all correspondence to: didier.hober@chru-lille.fr

1 Université Lille 2, CHRU, Laboratoire de Virologie/ EA3610, 59037 Lille, France

2 UPJV CHU, Service d'Endocrinologie-Diabétologie-Nutrition, 80054 Amiens, France

References

- [1] Aarnisalo, J., Veijola, R., Vainionpaa, R., Simell, O., Knip, M., & Ilonen, J. (2008). Cytomegalovirus infection in early infancy: risk of induction and progression of autoimmunity associated with type 1 diabetes. *Diabetologia* 51(5), 769-72.
- [2] Acharya, R., Fry, E., Stuart, D., Fox, G., Rowlands, D., & Brown, F. (1989). The three-dimensional structure of foot-and-mouth disease virus at 2.9 Å resolution. *Nature* 337(6209), 709-16.

- [3] Ahmad, N., & Abraham, A. A. (1982). Pancreatic isletitis with coxsackie virus B5 infection. *Hum Pathol.* 13(7), 661-2.
- [4] Andino, R., Boddeker, N., Silvera, D., & Gamarnik, A. V. (1999). Intracellular determinants of picornavirus replication. *Trends Microbiol.* 7(2), 76-82.
- [5] Andreoletti, L., Hober, D., Hober-Vandenberghe, C., Belaich, S., Vantyghem, M. C., Lefebvre, J., & Wattre, P. (1997). Detection of coxsackie B virus RNA sequences in whole blood samples from adult patients at the onset of type I diabetes mellitus. *J Med Virol.* 52(2), 121-7.
- [6] Bach, J.F. (2002). The effect of infections on susceptibility to autoimmune and allergic diseases. *N Engl J Med.* 347(12), 911 EOF-20 EOF.
- [7] Bach, J.F. (2005). Infections and autoimmune diseases. *J Autoimmun* 25 Suppl., 74-80.
- [8] Baek, H. S., & Yoon, J. W. (1990). Role of macrophages in the pathogenesis of encephalomyocarditis virus-induced diabetes in mice. *J Virol* 64(12), 5708-15.
- [9] Baek, H. S., & Yoon, J. W. (1991). Direct involvement of macrophages in destruction of beta-cells leading to development of diabetes in virus-infected mice. *Diabetes* 40(12), 1586-97.
- [10] Balada, E., Vilardell-Tarres, M., & Ordi-Ros, J. (2010). Implication of human endogenous retroviruses in the development of autoimmune diseases. *Int Rev Immunol* 29(4), 351-70.
- [11] Beyan, H., Drexhage, R. C., van der Heul, Nieuwenhuijsen. L., de Wit, H., Padmos, R. C., Schloot, N. C., Drexhage, H. A., & Leslie, R. D. (2010). Monocyte gene-expression profiles associated with childhood-onset type 1 diabetes and disease risk: a study of identical twins. *Diabetes* 59(7), 1751-5.
- [12] Blixt, M., Niklasson, B., & Sandler, S. (2007). Characterization of beta-cell function of pancreatic islets isolated from bank voles developing glucose intolerance/diabetes: an animal model showing features of both type 1 and type 2 diabetes mellitus, and a possible role of the Ljungman virus. *Gen Comp Endocrinol* 154(1-3), 41-7.
- [13] Bortell, R., Pino, S. C., Greiner, D. L., Zipris, D., & Rossini, A. A. (2008). Closing the circle between the bedside and the bench: Toll-like receptors in models of virally induced diabetes. *Ann N Y Acad Sci*, 1150, 112-22.
- [14] Brilot, F., Chehadeh, W., Charlet-Renard, C., Martens, H., Geenen, V., & Hober, D. (2002). Persistent infection of human thymic epithelial cells by coxsackievirus B4. *J Virol.* 76(10), 5260-5.
- [15] Brilot, F., Geenen, V., Hober, D., & Stoddart, C. A. (2004). Coxsackievirus B4 infection of human fetal thymus cells. *J Virol.* 78(18), 9854-61.
- [16] Brilot, F., Jaidane, H., Geenen, V., & Hober, D. (2008). Coxsackievirus B4 infection of murine foetal thymus organ cultures. *J Med Virol.* 80(4), 659-66.

- [17] Buesa-Gomez, J., de la Torre, J. C., Dyrberg, T., Landin-Olsson, M., Mauseth, R. S., Lernmark, A., & Oldstone, M. B. (1994). Failure to detect genomic viral sequences in pancreatic tissues from two children with acute-onset diabetes mellitus. *J Med Virol.* 42(2), 193-7.
- [18] Burgess, M. A., & Forrest, J. M. (2009). Congenital rubella and diabetes mellitus. *Diabetologia* 52(2), 369-70; author reply 373.
- [19] Cameron, C. E., Suk, Oh. H., & Moustafa, I. M. (2010). Expanding knowledge of 3 proteins in the poliovirus lifecycle. *Future Microbiol.* 5(6), 867-81.
- [20] Chakrabarti, D., Hultgren, B., & Stewart, T. A. (1996). IFN-alpha induces autoimmune T cells through the induction of intracellular adhesion molecule-1 and B7.2. *J Immunol.* 157(2), 522-8.
- [21] Champsaur, H., Dussaix, E., Samolyk, D., Fabre, M., Bach, C., & Assan, R. (1980). Diabetes and Coxsackie virus B5 infection. *Lancet* 1(8162), 251.
- [22] Chatterjee, N. K., Hou, J., Dockstader, P., & Charbonneau, T. (1992). Coxsackievirus B4 infection alters thymic, splenic, and peripheral lymphocyte repertoire preceding onset of hyperglycemia in mice. *J Med Virol.* 38(2), 124-31.
- [23] Chehadeh, W., Kerr-Conte, J., Pattou, F., Alm, G., Lefebvre, J., Wattré, P., & Hober, D. (2000a). Persistent infection of human pancreatic islets by coxsackievirus B is associated with alpha interferon synthesis in beta cells. *J Virol.* 74(21), 10153-64.
- [24] Chehadeh, W., Weill, J., Vantyghem, M. C., Alm, G., Lefebvre, J., Wattré, P., & Hober, D. (2000b). Increased level of interferon-alpha in blood of patients with insulin-dependent diabetes mellitus: relationship with coxsackievirus B infection. *J Infect Dis.* 181(6), 1929-39.
- [25] Chehadeh, W., Bouzidi, A., Alm, G., Wattré, P., & Hober, D. (2001). Human antibodies isolated from plasma by affinity chromatography increase the coxsackievirus B4-induced synthesis of interferon-alpha by human peripheral blood mononuclear cells in vitro. *J Gen Virol.* 82(Pt 8), 1899-907.
- [26] Chehadeh, W., Lobert, P. E., Sauter, P., Goffard, A., Lucas, B., Weill, J., Vantyghem, M. C., Alm, G., Pigny, P., & Hober, D. (2005). Viral protein VP4 is a target of human antibodies enhancing coxsackievirus B4 and B3-induced synthesis of alpha interferon. *J Virol.* 79(22), 13882-91.
- [27] Chiou, C. C., Chung, W. H., Hung, S. I., Yang, L. C., & Hong, H. S. (2006). Fulminant type 1 diabetes mellitus caused by drug hypersensitivity syndrome with human herpesvirus 6 infection. *J Am Acad Dermatol.* 54 (2 Suppl), S, 14-7.
- [28] Christen, U., Edelmann, K. H., Mc Gavern, D. B., Wolfe, T., Coon, B., Teague, M. K., Miller, S. D., Oldstone, M. B., & von Herrath, M. G. (2004). A viral epitope that mimics a self antigen can accelerate but not initiate autoimmune diabetes. *J Clin Invest.* 114(9), 1290-8.

- [29] Chung, Y. H., Jun, H. S., Kang, Y., Hirasawa, K., Lee, B. R., Van Rooijen, N., & Yoon, J. W. (1997). Role of macrophages and macrophage-derived cytokines in the pathogenesis of Kilham rat virus-induced autoimmune diabetes in diabetes-resistant Bio-Breeding rats. *J Immunol.* 159(1), 466-71.
- [30] Chung, Y. H., Jun, H. S., Son, M., Bao, M., Bae, H. Y., Kang, Y., & Yoon, J. W. (2000). Cellular and molecular mechanism for Kilham rat virus-induced autoimmune diabetes in DR-BB rats. *J. Immunol* 165(5), 2866-76.
- [31] Clements, G. B., Galbraith, D. N., & Taylor, K. W. (1995). Coxsackie B virus infection and onset of childhood diabetes. *Lancet* 346(8969), 221-3.
- [32] Colbere-Garapin, F., Christodoulou, C., Crainic, R., & Pelletier, I. (1989). Persistent poliovirus infection of human neuroblastoma cells. *Proc Natl Acad Sci U S A* 86(19), 7590-4.
- [33] Coleman, T. J., Gamble, D. R., & Taylor, K. W. (1973). Diabetes in mice after Coxsackie B 4 virus infection. *Br Med J.* 3(5870), 25-7.
- [34] Concannon, P., Rich, S. S., & Nepom, G. T. (2009). Genetics of type 1A diabetes. *N Engl J Med.* 360(16), 1646-54.
- [35] Coulson, B. S., Witterick, P. D., Tan, Y., Hewish, M. J., Mountford, J. N., Harrison, L. C., & Honeyman, M. C. (2002). Growth of rotaviruses in primary pancreatic cells. *J Virol* 76(18), 9537-44.
- [36] Coutant, R., Carel, J. C., Lebon, P., Bougnères, P. F., Palmer, P., & Cantero-Aguilar, L. (2000). Detection of enterovirus RNA sequences in serum samples from autoantibody-positive subjects at risk for diabetes. *Diabet Med.* 19(11), 968-9.
- [37] Craig, M. E., Howard, N. J., Silink, M., & Rawlinson, W. D. (2003). Reduced frequency of HLA DRB1*03DQB1*02 in children with type 1 diabetes associated with enterovirus RNA. *J Infect Dis.* 187(10), 1562-70.
- [38] Crampton, S. P., Deane, J. A., Feigenbaum, L., & Bolland, S. (2011). IFIH1 gene dose effect reveals MDA-5 mediated chronic type I IFN gene signature, viral resistance and accelerated autoimmunity. *J Immunol, DOI:In Press.*
- [39] Dahlquist, G. G., Forsberg, J., Hagenfeldt, L., Boman, J., & Juto, P. (2004). Increased prevalence of enteroviral RNA in blood spots from newborn children who later developed type 1 diabetes: a population-based case-control study. *Diabetes Care* 27(1), 285-6.
- [40] Deonarain, R., Cerullo, D., Fuse, K., Liu, P. P., & Fish, E. N. (2004). Protective role for interferon-beta in coxsackievirus B3 infection. *Circulation* 110(23), 3540-3.
- [41] De Stefano, F., Mullooly, J. P., Okoro, C. A., Chen, R. T., Marcy, S. M., Ward, J. I., Vadheim, C. M., Black, S. B., Shinefield, H. R., Davis, R. L., & Bohlke, K. (2001). Childhood vaccinations, vaccination timing, and risk of type 1 diabetes mellitus. *Pediatrics* 108(6), E112.

- [42] Di Pietro, C., Del Guercio, M. J., Paolino, G. P., Barbi, M., Ferrante, P., & Chiumello, G. (1979). Type 1 diabetes and Coxsackie virus infection. *Helv Paediatr Acta* 34(6), 557-61.
- [43] Dotta, F., Censini, S., van Halteren, A. G., Marselli, L., Masini, M., Dionisi, S., Mosca, F., Boggi, U., Muda, A. O., Prato, S. D., Elliott, J. F., Covacci, A., Rappuoli, R., Roep, B. O., & Marchetti, P. (2007). Coxsackie B4 virus infection of beta cells and natural killer cell insulinitis in recent-onset type 1 diabetic patients. *Proc Natl Acad Sci U S A* 104(12), 5115-20.
- [44] Dudek, N. L., Thomas, H. E., Mariana, L., Sutherland, R. M., Allison, J., Estella, E., Angstetra, E., Trapani, J. A., Santamaria, P., Lew, A. M., & Kay, T. W. (2006). Cytotoxic T-cells from T-cell receptor transgenic NOD8.3 mice destroy beta-cells via the perforin and Fas pathways. *Diabetes* 55(9), 2412-8.
- [45] Eizirik, D. L., Colli, M. L., & Ortis, F. (2009). The role of inflammation in insulinitis and beta-cell loss in type 1 diabetes. *Nat Rev Endocrinol.* 5(4), 219-26.
- [46] Ejrnaes, M., von Herrath, M. G., & Christen, U. (2006). Cure of chronic viral infection and virus-induced type 1 diabetes by neutralizing antibodies. *Clin Dev Immunol.* 13(2-4), 337-47.
- [47] Ellerman, K. E., Richards, C. A., Guberski, D. L., Shek, W. R., & Like, A. A. (1996). Kilham rat triggers T-cell-dependent autoimmune diabetes in multiple strains of rat. *Diabetes* 45(5), 557-62.
- [48] Filippi, C.M., & von Herrath, M.G. (2008). Viral trigger for type 1 diabetes: pros and cons. *Diabetes* 57(11), 2863-71.
- [49] Filippi, C. M., Estes, E. A., Oldham, J. E., & von Herrath, M. G. (2009). Immunoregulatory mechanisms triggered by viral infections protect from type 1 diabetes in mice. *J Clin Invest* 119(6), 1515-23.
- [50] Flodstrom, M., Maday, A., Balakrishna, D., Cleary, M. M., Yoshimura, A., & Sarvetnick, N. (2002). Target cell defense prevents the development of diabetes after viral infection. *Nat Immunol.* 3(4), 373-82.
- [51] Foulis, A. K., Farquharson, M. A., & Meager, A. (1987). Immunoreactive alpha-interferon in insulin-secreting beta cells in type 1 diabetes mellitus. *Lancet* 2 (8573), 1423-7.
- [52] Foulis, A. K., Farquharson, M. A., Cameron, S. O., Mc Gill, M., Schonke, H., & Kandolf, R. (1990). A search for the presence of the enteroviral capsid protein VP1 in pancreases of patients with type 1 (insulin-dependent) diabetes and pancreases and hearts of infants who died of coxsackieviral myocarditis. *Diabetologia* 33(5), 290-8.
- [53] Foy, C. A., Quirke, P., Lewis, F. A., Futers, T. S., & Bodansky, H. J. (1995). Detection of common viruses using the polymerase chain reaction to assess levels of viral presence in type 1 (insulin-dependent) diabetic patients. *Diabet Med.* 12(11), 1002-8.

- [54] Freimuth, P., Philipson, L., & Carson, S. D. (2008). The coxsackievirus and adenovirus receptor. *Curr Top Microbiol Immunol.* , 323, 67-87.
- [55] Frisk, G., & Diderholm, H. (2000). Tissue culture of isolated human pancreatic islets infected with different strains of coxsackievirus B4: assessment of virus replication and effects on islet morphology and insulin release. *Int J Exp Diabetes Res.* 1(3), 165-75.
- [56] Gale, E.A. (2008). Congenital rubella: citation virus or viral cause of type 1 diabetes? *Diabetologia* 51(9), 1559-66.
- [57] Gerling, I., Chatterjee, N. K., & Nejman, C. (1991). Coxsackievirus B4-induced development of antibodies to 64000Mr islet autoantigen and hyperglycemia in mice. *Autoimmunity* 10(1), 49-56.
- [58] Girn, J., Kavooosi, M., & Chantler, J. (2002). Enhancement of coxsackievirus B3 infection by antibody to a different coxsackievirus strain. *J Gen Virol.* 83(Pt 2), 351-8.
- [59] Goto, A., Takahashi, Y., Kishimoto, M., Nakajima, Y., Nakanishi, K., Kajio, H., & No-da, M. (2008). A case of fulminant type 1 diabetes associated with significant elevation of mumps titers. *Endocr J.* 55(3), 561-4.
- [60] Graham, K. L., Sanders, N., Tan, Y., Allison, J., Kay, T. W., & Coulson, B. S. (2008). Rotavirus infection accelerates type 1 diabetes in mice with established insulinitis. *J Virol.* 82(13), 6139-49.
- [61] Hanafusa, T., & Imagawa, A. (2007). Fulminant type 1 diabetes: a novel clinical entity requiring special attention by all medical practitioners. *Nat Clin Pract Endocrinol Metab* 3(1), 36-45; quiz 2p following 69.
- [62] Helmke, K., Otten, A., & Willems, W. (1980). Islet cell antibodies in children with mumps infection. *Lancet* 2(8187), 211-2.
- [63] Henke, A., Huber, S., Stelzner, A., & Whitton, J. L. (1995). The role of CD8+ T lymphocytes in coxsackievirus B3-induced myocarditis. *J Virol.* 69(11), 6720-8.
- [64] Hiemstra, H. S., Schloot, N. C., van Veelen, P. A., Willemsen, S. J., Franken, K. L., van Rood, J. J., de Vries, R. R., Chaudhuri, A., Behan, P. O., Drijfhout, J. W., & Roep, B. O. (2001). Cytomegalovirus in autoimmunity: T cell crossreactivity to viral antigen and autoantigen glutamic acid decarboxylase. *Proc Natl Acad Sci U S A* 98(7), 3988-91.
- [65] Hillebrands, J. L., van der Werf, N., Klatter, F. A., Bruggeman, C. A., & Rozing, J. (2003). Role of peritoneal macrophages in cytomegalovirus-induced acceleration of autoimmune diabetes in BB-rats. *Clin Dev Immunol.* 10(2-4), 133-9.
- [66] Hober, D., Chehadeh, W., Bouzidi, A., & Wattré, P. (2001). Antibody-dependent enhancement of coxsackievirus B4 infectivity of human peripheral blood mononuclear cells results in increased interferon-alpha synthesis. *J Infect Dis.* 184(9), 1098-108.
- [67] Hober, D., Chehadeh, W., Weill, J., Hober, C., Vantuyghem, M. C., Gronnier, P., & Wattré, P. (2002). Circulating and cell-bound antibodies increase coxsackievirus B4 in-

- duced production of IFN- α by peripheral blood mononuclear cells from patients with type 1 diabetes. *J Gen Virol.* 83(Pt 9), 2169-76.
- [68] Hogle, J.M. (2002). Poliovirus cell entry: common structural themes in viral cell entry pathways. *Annu Rev Microbiol.*, 56, 677-702.
- [69] Hogle, J. M., Chow, M., & Filman, D. J. (1985). Three-dimensional structure of poliovirus at 2.9 Å resolution. *Science* 229(4720), 1358-65.
- [70] Honeyman, M. C., Coulson, B. S., Stone, N. L., Gellert, S. A., Goldwater, P. N., Steele, C. E., Couper, J. J., Tait, B. D., Colman, P. G., & Harrison, L. C. (2000). Association between rotavirus infection and pancreatic islet autoimmunity in children at risk of developing type 1 diabetes. *Diabetes* 49(8), 1319-24.
- [71] Honeyman, M. C., & Harrison, L. C. (2009). Congenital rubella, diabetes and HLA. *Diabetologia* 52(2), 371-2; author reply 373.
- [72] Honeyman, M. C., Stone, N. L., Falk, B. A., Nepom, G., & Harrison, L. C. (2010). Evidence for molecular mimicry between human T cell epitopes in rotavirus and pancreatic islet autoantigens. *J Immunol.* 184(4), 2204-10.
- [73] Horwitz, M. S., Bradley, L. M., Harbertson, J., Krahl, T., Lee, J., & Sarvetnick, N. (1998). Diabetes induced by Coxsackie virus: initiation by bystander damage and not molecular mimicry. *Nat Med.* 4(7), 781-5.
- [74] Horwitz, M. S., Fine, C., Ilic, A., & Sarvetnick, N. (2001). Requirements for viral-mediated autoimmune diabetes: beta-cell damage and immune infiltration. *J Autoimmun.* 16(3), 211-7.
- [75] Horwitz, M. S., Ilic, A., Fine, C., Balasa, B., & Sarvetnick, N. (2004). Coxsackieviral-mediated diabetes: induction requires antigen-presenting cells and is accompanied by phagocytosis of beta cells. *Clin Immunol.* 110(2), 134-44.
- [76] Huang, X., Yuang, J., Goddard, A., Foulis, A., James, R. F., Lernmark, A., Pujol-Borrell, R., Rabinovitch, A., Somoza, N., & Stewart, T. A. (1995). Interferon expression in the pancreases of patients with type I diabetes. *Diabetes* 44(6), 658-64.
- [77] Hultcrantz, M., Huhn, M. H., Wolf, M., Olsson, A., Jacobson, S., Williams, B. R., Korsgren, O., & Flodstrom-Tullberg, M. (2007). Interferons induce an antiviral state in human pancreatic islet cells. *Virology* 367(1), 92-101.
- [78] Hviid, A., Stellfeld, M., Wohlfahrt, J., & Melbye, M. (2004). Childhood vaccination and type 1 diabetes. *N Engl J Med.* 350(14), 1398-404.
- [79] Hyoty, H., Hiltunen, M., Reunanen, A., Leinikki, P., Vesikari, T., Lounamaa, R., Tuomilehto, J., & Akerblom, H. K. (1993a). Decline of mumps antibodies in type 1 (insulin-dependent) diabetic children and a plateau in the rising incidence of type 1 diabetes after introduction of the mumps-measles-rubella vaccine in Finland. Childhood Diabetes in Finland Study Group. *Diabetologia* 36(12), 1303-8.

- [80] Hyoty, H., Parkkonen, P., Rode, M., Bakke, O., & Leinikki, P. (1993b). Common peptide epitope in mumps virus nucleocapsid protein and MHC class II-associated invariant chain. *Scand J Immunol.* 37(5), 550-8.
- [81] Jaidane, H., Gharbi, J., Lobert, P. E., Caloone, D., Lucas, B., Sane, F., Idziorek, T., Romond, M. B., Aouni, M., & Hober, D. (2008). Infection of primary cultures of murine splenic and thymic cells with coxsackievirus B4. *Microbiol Immunol.* 52(1), 40-6.
- [82] Jaidane, H., & Hober, D. (2008). Role of coxsackievirus B4 in the pathogenesis of type 1 diabetes. *Diabetes Metab.* 34(6 Pt 1), 537-48.
- [83] Jaidane, H., Sane, F., Gharbi, J., Aouni, M., Romond, M. B., & Hober, D. (2009). Coxsackievirus B4 and type 1 diabetes pathogenesis: contribution of animal models. *Diabetes Metab Res Rev.* 25(7), 591-603.
- [84] Jun, H. S., Kang, Y., Notkins, A. L., & Yoon, J. W. (1997). Gain or loss of diabetogenicity resulting from a single point mutation in recombinant encephalomyocarditis virus. *J Virol.* 71(12), 9782-5.
- [85] Jun, H. S., Kang, Y., Yoon, H. S., Kim, K. H., Notkins, A. L., & Yoon, J. W. (1998). Determination of encephalomyocarditis viral diabetogenicity by a putative binding site of the viral capsid protein. *Diabetes* 47(4), 576-82.
- [86] Kallewaard, N. L., Zhang, L., Chen, J. W., Guttenberg, M., Sanchez, M. D., & Bergelson, J. M. (2009). Tissue-specific deletion of the coxsackievirus and adenovirus receptor protects mice from virus-induced pancreatitis and myocarditis. *Cell Host Microbe* 6(1), 91-8.
- [87] Kanazawa, Y., Komeda, K., Sato, S., Mori, S., Akanuma, K., & Takaku, F. (1984). Non-obese-diabetic mice: immune mechanisms of pancreatic beta-cell destruction. *Diabetologia* 27 Suppl., 113-5.
- [88] Kasuga, A., Harada, R., & Saruta, T. (1996). Insulin-dependent diabetes mellitus associated with parvovirus B19 infection. *Ann Intern Med.* 125(8), 700-1.
- [89] Kaufman, D. L., Clare-Salzler, M., Tian, J., Forsthuber, T., Ting, G. S., Robinson, P., Atkinson, M. A., Sercarz, E. E., Tobin, A. J., & Lehmann, P. V. (1993). Spontaneous loss of T-cell tolerance to glutamic acid decarboxylase in murine insulin-dependent diabetes. *Nature*, 69-72.
- [90] Kawashima, H., Ihara, T., Ioi, H., Oana, S., Sato, S., Kato, N., Takami, T., Kashiwagi, Y., Takekuma, K., Hoshika, A., & Mori, T. (2004). Enterovirus-related type 1 diabetes mellitus and antibodies to glutamic acid decarboxylase in Japan. *J Infect.* 49(2), 147-51.
- [91] Kembal, C. C., Alirezaei, M., & Whitton, J. L. (2010). Type B coxsackieviruses and their interactions with the innate and adaptive immune systems. *Future Microbiol.* 5(9), 1329-1347.

- [92] Kishimoto, C., Kurokawa, M., & Ochiai, H. (2002). Antibody-mediated immune enhancement in coxsackievirus B3 myocarditis. *J Mol Cell Cardiol* 34(9), 1227 -1238 .
- [93] Klemola, P., Kaijalainen, S., Ylipaasto, P., & Roivainen, M. (2008). Diabetogenic effects of the most prevalent enteroviruses in Finnish sewage. *Ann N Y Acad Sci.*, 1150, 210-2.
- [94] Kondrashova, A., Reunanen, A., Romanov, A., Karvonen, A., Viskari, H., Vesikari, T., Ilonen, J., Knip, M., & Hyoty, H. (2005). A six-fold gradient in the incidence of type 1 diabetes at the eastern border of Finland. *Ann Med.* 37(1), 67 -72 .
- [95] Korostoff, J. M., Nakada, M. T., Faas, S. J., Blank, K. J., & Gaulton, G. N. (1990). Neonatal exposure to thymotropic gross murine leukemia virus induces virus-specific immunologic nonresponsiveness. *J Exp Med.* 172(6), 1765-75.
- [96] Li, Q., Yafal, A. G., Lee, Y. M., Hogle, J., & Chow, M. (1994). Poliovirus neutralization by antibodies to internal epitopes of VP4 and VP1 results from reversible exposure of these sequences at physiological temperature. *J Virol.* 68(6), 3965-70.
- [97] Lin, J. Y., Chen, T. C., Weng, K. F., Chang, S. C., Chen, L. L., & Shih, S. R. (2009). Viral and host proteins involved in picornavirus life cycle. *J Biomed Sci.* 16, 103.
- [98] Lindberg, B., Ahlfors, K., Carlsson, A., Ericsson, U. B., Landin-Olsson, M., Lernmark, A., Ludvigsson, J., Sundkvist, G., & Ivarsson, S. A. (1999). Previous exposure to measles, mumps, and rubella--but not vaccination during adolescence--correlates to the prevalence of pancreatic and thyroid autoantibodies. *Pediatrics* 104(1), e12.
- [99] Lonrot, M., Salminen, K., Knip, M., Savola, K., Kulmala, P., Leinikki, P., Hyypia, T., Akerblom, H. K., & Hyoty, H. (2000). Enterovirus RNA in serum is a risk factor for beta-cell autoimmunity and clinical type 1 diabetes: a prospective study. Childhood Diabetes in Finland (DiMe) Study Group. *J Med Virol.* 61(2), 214-20.
- [100] Maha, M. M., Ali, M. A., Abdel-Rehim, S. E., Abu-Shady, E. A., El -Naggar, B. M., & Maha, Y. Z. (2003). The role of coxsackieviruses infection in the children of insulin dependent diabetes mellitus. *J Egypt Public Health Assoc.* 78(3-4), 305-18.
- [101] Marguerat, S., Wang, W. Y., Todd, J. A., & Conrad, B. (2004). Association of human endogenous retrovirus K-18 polymorphisms with type 1 diabetes. *Diabetes* 53(3), 852-4.
- [102] Mc Cartney, S. A., Vermi, W., Lonardi, S., Rossini, C., Otero, K., Calderon, B., Gilfillan, S., Diamond, M. S., Unanue, E. R., & Colonna, M. (2011). RNA sensor-induced type I IFN prevents diabetes caused by a beta cell-tropic virus in mice. *J Clin Invest.*
- [103] Mena, I., Perry, C. M., Harkins, S., Rodriguez, F., Gebhard, J., & Whitton, J. L. (1999). The role of B lymphocytes in coxsackievirus B3 infection. *Am J Pathol.* 155(4), 1205-15.
- [104] Moya-Suri, V., Schlosser, M., Zimmermann, K., Rjasanowski, I., Gurtler, L., & Mentel, R. (2005). Enterovirus RNA sequences in sera of schoolchildren in the general popu-

- lation and their association with type 1 diabetes-associated autoantibodies. *J Med Microbiol.* 54(Pt 9), 879-83.
- [105] Muckelbauer, J. K., Kremer, M., Minor, I., Diana, G., Dutko, F. J., Groarke, J., Pevear, D. C., & Rossmann, M. G. (1995). The structure of coxsackievirus B3 at 3.5 Å resolution. *Structure* 3(7), 653-67.
- [106] Munakata, Y., Koderu, T., Saito, T., & Sasaki, T. (2005). Rheumatoid arthritis, type 1 diabetes, and Graves' disease after acute parvovirus B19 infection. *Lancet* 366(9487), 780.
- [107] Nair, S., Leung, K. C., Rawlinson, W. D., Naing, Z., & Craig, M. E. (2010). Enterovirus infection induces cytokine and chemokine expression in insulin-producing cells. *J Med Virol.* 82(11), 1950-7.
- [108] Nairn, C., Galbraith, D. N., Taylor, K. W., & Clements, G. B. (1999). Enterovirus variants in the serum of children at the onset of Type 1 diabetes mellitus. *Diabet Med.* 16(6), 509-13.
- [109] Niklasson, B., Heller, K. E., Schonecker, B., Bildsoe, M., Daniels, T., Hampe, C. S., Wildlund, P., Simonson, W. T., Schaefer, J. B., Rutledge, E., Bekris, L., Lindberg, A. M., Johansson, S., Ortqvist, E., Persson, B., & Lernmark, A. (2003). Development of type 1 diabetes in wild bank voles associated with islet autoantibodies and the novel ljun-gan virus. *Int J Exp Diabetes Res.* 4(1), 35-44.
- [110] Niklasson, B., Samsioe, A., Blixt, M., Sandler, S., Sjöholm, A., Lagerquist, E., Lernmark, A., & Klitz, W. (2006). Prenatal viral exposure followed by adult stress produces glucose intolerance in a mouse model. *Diabetologia* 49(9), 2192-9.
- [111] Nugent, C. I., Johnson, K. L., Sarnow, P., & Kirkegaard, K. (1999). Functional coupling between replication and packaging of poliovirus replicon RNA. *J Virol.* 73(1), 427-35.
- [112] Numazaki, K., Goldman, H., Wong, I., & Wainberg, M. A. (1988). Viral infection of human fetal islets of Langerhans. Replication of human cytomegalovirus in cultured human fetal pancreatic islets. *Am J Clin Pathol.* 90(1), 52-7.
- [113] O'Brayan, T. A., Beck, M. J., Demers, L. M., & Naides, S. J. (2005). Human parvovirus B19 infection in children with new onset Type 1 diabetes mellitus. *Diabet Med.* 22(12), 1778-9.
- [114] Oikarinen, M., Tauriainen, S., Honkanen, T., Oikarinen, S., Vuori, K., Kaukinen, K., Rantala, I., Maki, M., & Hyoty, H. (2008). Detection of enteroviruses in the intestine of type 1 diabetic patients. *Clin Exp Immunol.* 151(1), 71-5.
- [115] Oikarinen, S., Martiskainen, M., Tauriainen, S., Huhtala, H., Ilonen, J., Veijola, R., Simell, O., Knip, M., & Hyoty, H. (2011). Enterovirus RNA in blood is linked to the development of type 1 diabetes. *Diabetes* 60(1), 276-9.

- [116] Oldstone, M. B., Nerenberg, M., Southern, P., Price, J., & Lewicki, H. (1991). Virus infection triggers insulin-dependent diabetes mellitus in a transgenic model: role of anti-self (virus) immune response. *Cell* 65(2), 319-31.
- [117] Olsson, A., Johansson, U., Korsgren, O., & Frisk, G. (2005). Inflammatory gene expression in Coxsackievirus B-4infected human islets of Langerhans. *Biochem Biophys Res Commun* 330(2), 571-6.
- [118] Ou, D., Mitchell, L. A., Metzger, D. L., Gillam, S., & Tingle, A. J. (2000). Cross-reactive rubella virus and glutamic acid decarboxylase (65 and 67) protein determinants recognised by T cells of patients with type I diabetes mellitus. *Diabetologia* 43(6), 750-62.
- [119] Parkkonen, P., Hyoty, H., Koskinen, L., & Leinikki, P. (1992). Mumps virus infects beta cells in human fetal islet cell cultures upregulating the expression of HLA class I molecules. *Diabetologia* 35(1), 63-9.
- [120] Ramondetti, F., Sacco, S., Comelli, M., Bruno, G., Falorni, A., Iannilli, A., D'Annunzio, G., Iafusco, D., Songini, M., Toni, S., Cherubini, V., & Carle, F. (2011). RIDI study group. Type 1 diabetes and measles, mumps and rubella childhood infections within the Italian Insulin-dependent diabetes Registry. *Diabet Med*, 1464-5491.
- [121] Rayfield, E. J., Kelly, K. J., & Yoon, J. W. (1986). Rubella virus-induced diabetes in the hamster. *Diabetes* 35(11), 1278-81.
- [122] Richardson, S. J., Willcox, A., Bone, A. J., Foulis, A. K., & Morgan, N. G. (2009). The prevalence of enteroviral capsid protein vp1 immunostaining in pancreatic islets in human type 1 diabetes. *Diabetologia* 52(6), 1143-51.
- [123] Richer, M. J., Lavallee, D. J., Shanina, I., & Horwitz, M. S. (2009). Toll-like receptor 3 signaling on macrophages is required for survival following coxsackievirus B4 infection. *PLoS One* 4(1), e4127.
- [124] Roivainen, M., Rasilainen, S., Ylipaasto, P., Nissinen, R., Ustinov, J., Bouwens, L., Eizirik, D. L., Hovi, T., & Otonkoski, T. (2000). Mechanisms of coxsackievirus-induced damage to human pancreatic beta-cells. *J Clin Endocrinol Metab* 85(1), 432-40.
- [125] Salminen, K. K., Vuorinen, T., Oikarinen, S., Helminen, M., Simell, S., Knip, M., Ilonen, J., Simell, O., & Hyoty, H. (2004). Isolation of enterovirus strains from children with preclinical Type 1 diabetes. *Diabet Med*. 21(2), 156-64.
- [126] Sano, H., Terasaki, J., Tsutsumi, C., Imagawa, A., & Hanafusa, T. (2008). A case of fulminant type 1 diabetes mellitus after influenza B infection. *Diabetes Res Clin Pract*. 79(3), e, 8-9.
- [127] Sarmiento, L., Cabrera-Rode, E., Lekuleni, L., Cuba, I., Molina, G., Fonseca, M., Heng-Hung, L., Borroto, A. D., Gonzalez, P., Mas-Lago, P., & Diaz-Horta, O. (2007). Occurrence of enterovirus RNA in serum of children with newly diagnosed type 1 diabetes and islet cell autoantibody-positive subjects in a population with a low incidence of type 1 diabetes. *Autoimmunity* 40(7), 540-5.

- [128] Sato, K., Inaba, Y., Shinozaki, T., Fujii, R., & Matumoto, M. (1981). Isolation of human rotavirus in cell cultures: brief report. *Arch Virol.* 69(2), 155-60.
- [129] Sauter, P., Lobert, P. E., Lucas, B., Varela-Calvino, R., Alm, G., Wattre, P., & Hober, D. (2007). Role of the capsid protein VP4 in the plasma-dependent enhancement of the Coxsackievirus B4E2infection of human peripheral blood cells. *Virus Res.* 125(2), 183-90.
- [130] Sauter, P., Chehadeh, W., Lobert, P. E., Lazrek, M., Goffard, A., Soumillon, M., Caloone, D., Vantyghe, M. C., Weill, J., Fajardy, I., Alm, G., Lucas, B., & Hober, D. (2008). A part of the VP4 capsid protein exhibited by coxsackievirus B4 E2 is the target of antibodies contained in plasma from patients with type 1 diabetes. *J Med Virol.* 80(5), 866-78.
- [131] Sauter, P., & Hober, D. (2009). Mechanisms and results of the antibody-dependent enhancement of viral infections and role in the pathogenesis of coxsackievirus B-induced diseases. *Microbes Infect.* 11(4), 443-51.
- [132] Schulte, B. M., Bakkens, J., Lanke, K. H., Melchers, W. J., Westerlaken, C., Allebes, W., Aanstoot, H. J., Bruining, G. J., Adema, G. J., Van Kuppeveld, F. J., & Galama, J. M. (2010). Detection of enterovirus RNA in peripheral blood mononuclear cells of type 1 diabetic patients beyond the stage of acute infection. *Viral Immunol.* 23(1), 99-104.
- [133] See, D. M., & Tilles, J. G. (1995). Pathogenesis of virus-induced diabetes in mice. *J Infect Dis.* 171(5), 1131-8.
- [134] Serreze, D. V., Ottendorfer, E. W., Ellis, T. M., Gauntt, C. J., & Atkinson, M. A. (2000). Acceleration of type 1 diabetes by a coxsackievirus infection requires a preexisting critical mass of autoreactive T-cells in pancreatic islets. *Diabetes* 49(5), 708-11.
- [135] Shimada, A., & Maruyama, T. (2004). Encephalomyocarditis-virus-induced diabetes model resembles "fulminant" type 1 diabetes in humans. *Diabetologia* 47(10), 1854-5.
- [136] Singer, K. H., & Haynes, B. F. (1987). Epithelial-thymocyte interactions in human thymus. *Hum Immunol* 20(2), 127-44.
- [137] Smelt, M. J., Faas, M. M., de Haan, B. J., Hofstede, J., Cheung, C. W., van der Iest, H., de Haan, A., & de Vos, P. (2010). Rat pancreatic beta cells and cytomegalovirus infection. *Pancreas* 39(1), 47-56.
- [138] Smyth, M.S., & Martin, J.H. (2002). Picornavirus uncoating. *Mol Pathol.* 55(4), 214-9.
- [139] Soltesz, G., Patterson, C. C., & Dahlquist, G. (2007). Worldwide childhood type 1 diabetes incidence--what can we learn from epidemiology? *Pediatr Diabetes* 8 Suppl., 6, 6-14.
- [140] Stark, G.R. (2007). How cells respond to interferons revisited: from early history to current complexity. *Cytokine Growth Factor Rev.* 18(5-6), 419 -423 .
- [141] Stene, L. C., Oikarinen, S., Hyoty, H., Barriga, K. J., Norris, J. M., Klingensmith, G., Hutton, J. C., Erlich, H. A., Eisenbarth, G. S., & Rewers, M. (2010). Enterovirus infec-

tion and progression from islet autoimmunity to type 1 diabetes: the Diabetes and Autoimmunity Study in the Young (DAISY). *Diabetes* 59(12), 3174-80.

- [142] Stewart, T. A., Hultgren, B., Huang, X., Pitts-Meek, S., Hully, J., & MacLachlan, N. J. (1993). Induction of type I diabetes by interferon-alpha in transgenic mice. *Science* 260(5116), 1942-6.
- [143] Sutkowski, N., Conrad, B., Thorley-Lawson, D. A., & Huber, B. T. (2001). Epstein-Barr virus transactivates the human endogenous retrovirus HERV-K18 that encodes a superantigen. *Immunity* 15(4), 579-89.
- [144] Tai, A. K., Luka, J., Ablashi, D., & Huber, B. T. (2009). HHV-6A infection induces expression of HERV-K18 encoded superantigen. *J Clin Virol.* 46(1), 47-8.
- [145] Takada, A., & Kawaoka, Y. (2003). Antibody-dependent enhancement of viral infection: molecular mechanisms and in vivo implications. *Rev Med Virol.* 13(6), 387-98.
- [146] Takeuchi, O., & Akira, S. (2008). MDA5/RIG-I and virus recognition. *Curr Opin Immunol.* 20(1), 17-22.
- [147] Taniguchi, T., Okazaki, K., Okamoto, M., Seko, S., Nagashima, K., Yamada, Y., Iwakura, T., & Seino, Y. (2005). Autoantibodies against the exocrine pancreas in fulminant type 1 diabetes. *Pancreas* 30(2), 191-2.
- [148] Tapia, G., Cinek, O., Rasmussen, T., Grinde, B., Stene, L. C., & Ronningen, K. S. (2011a). Longitudinal study of parechovirus infection in infancy and risk of repeated positivity for multiple islet autoantibodies: the MIDIA study. *Pediatr Diabetes* 12(1), 58-62.
- [149] Tapia, G., Cinek, O., Rasmussen, T., Witso, E., Grinde, B., Stene, L. C., & Ronningen, K. S. (2011b). Human enterovirus RNA in monthly fecal samples and islet autoimmunity in Norwegian children with high genetic risk for type 1 diabetes: the MIDIA study. *Diabetes Care* 34(1), 151-5.
- [150] The Juvenile Diabetes Research Foundation: The Network for Pancreatic Organ Donors with Diabetes. www.jdrfnpod.org.
- [151] Tian, J., Lehmann, P. V., & Kaufman, D. L. (1994). T cell cross-reactivity between coxsackievirus and glutamate decarboxylase is associated with a murine diabetes susceptibility allele. *J Exp Med.* 180(5), 1979-84.
- [152] Tisch, R., Yang, X. D., Singer, S. M., Liblau, R. S., Fugger, L., & McDevitt, H. O. (1993). Immune response to glutamic acid decarboxylase correlates with insulinitis in non-obese diabetic mice. *Nature* 366(6450), 72-5.
- [153] Toniolo, A., Onodera, T., Yoon, J. W., & Notkins, A. L. (1980). Induction of diabetes by cumulative environmental insults from viruses and chemicals. *Nature* 288(5789), 383-5.

- [154] Toniolo, A., Maccari, G., Federico, G., Salvatori, A., Bianchi, G., & Baj, A. (2010). Are enterovirus infections linked to the early stages of type 1 diabetes? *American Society for Microbiology Meeting, San Diego, CA*.
- [155] Tracy, S., Drescher, K. M., Chapman, N. M., Kim, K. S., Carson, S. D., Pirruccello, S., Lane, P. H., Romero, J. R., & Leser, J. S. (2002). Toward testing the hypothesis that group B coxsackieviruses (CVB) trigger insulin-dependent diabetes: inoculating non-obese diabetic mice with CVB markedly lowers diabetes incidence. *J Virol.* 76(23), 12097-111.
- [156] Tracy, S., & Drescher, K. M. (2007). Coxsackievirus infections and NOD mice: relevant models of protection from, and induction of, type 1 diabetes. *Ann N Y Acad Sci.*, 1103, 143-51.
- [157] Tracy, S., Drescher, K. M., Jackson, J. D., Kim, K., & Kono, K. (2010). Enteroviruses, type 1 diabetes and hygiene: a complex relationship. *Rev Med Virol.* 20(2), 106-16.
- [158] Tracy, S., Drescher, K. M., & Chapman, N. M. (2011). Enteroviruses and type 1 diabetes. *Diabetes metab Res rev.* 27(8), 820-3.
- [159] Tuthill, T. J., Groppelli, E., Hogle, J. M., & Rowlands, D. J. (2010). Picornaviruses. *Curr Top Microbiol Immunol*, 343, 43-89.
- [160] van Belle, T.L., Coppieters, K.T., & von Herrath, M.G. (2011). Type 1 diabetes: etiology, immunology, and therapeutic strategies. *Physiol Rev.* 91(1), 79-118.
- [161] van der Werf, N., Hillebrands, J. L., Klatter, F. A., Bos, I., Bruggeman, C. A., & Rozing, J. (2003). Cytomegalovirus infection modulates cellular immunity in an experimental model for autoimmune diabetes. *Clin Dev Immunol.* 10(2-4), 153-60.
- [162] van der Werf, N., Kroese, F. G. M., Rozing, J., & Hillebrands, J. L. (2007). Viral infections as potential triggers of type 1 diabetes. *Diabetes Metab Res Rev.* (23), 169-83.
- [163] Vehik, K., & Dabelea, D. (2011). The changing epidemiology of type 1 diabetes: why is it going through the roof? *Diabetes Metab Res Rev.* 27(1), 3-13.
- [164] Vigeant, P., Menard, H. A., & Boire, G. (1994). Chronic modulation of the autoimmune response following parvovirus B19 infection. *J Rheumatol* 21(6), 1165-7.
- [165] Viskari, H., Paronen, J., Keskinen, P., Simell, S., Zawilinska, B., Zgorniak-Nowosielska, I., Korhonen, S., Ilonen, J., Simell, O., Haapala, A. M., Knip, M., & Hyoty, H. (2003). Humoral beta-cell autoimmunity is rare in patients with the congenital rubella syndrome. *Clin Exp Immunol.* 133(3), 378-83.
- [166] von, Poblitzki. A., Gerdes, C., Reischl, U., Wolf, H., & Modrow, S. (1996). Lymphoproliferative responses after infection with human parvovirus B19. *J Virol* 70(10), 7327-30.
- [167] Vuorinen, T., Nikolakaros, G., Simell, O., Hyypia, T., & Vainionpaa, R. (1992). Mumps and Coxsackie B3 virus infection of human fetal pancreatic islet-like cell clusters. *Pancreas* 7(4), 460-4.

- [168] Wang, J. P., Asher, D. R., Chan, M., Kurt-Jones, E. A., & Finberg, R. W. (2007). Cutting Edge: Antibody-mediated TLR7-dependent recognition of viral RNA. *J Immunol.* 178(6), 3363-7.
- [169] Wessely, R., Klingel, K., Knowlton, K. U., & Kandolf, R. (2001). Cardiospecific infection with coxsackievirus B3 requires intact type I interferon signaling: implications for mortality and early viral replication. *Circulation* 103(5), 756-61.
- [170] Wicker, L. S., Todd, J. A., & Peterson, L. B. (1995). Genetic control of autoimmune diabetes in the NOD mouse. *Annu Rev Immunol.*, 13, 179-200.
- [171] Yin, H., Berg, A. K., Tuvemo, T., & Frisk, G. (2002). Enterovirus RNA is found in peripheral blood mononuclear cells in a majority of type 1 diabetic children at onset. *Diabetes* 51(6), 1964-71.
- [172] Ylipaasto, P., Klingel, K., Lindberg, A. M., Otonkoski, T., Kandolf, R., Hovi, T., & Roivainen, M. (2004). Enterovirus infection in human pancreatic islet cells, islet tropism in vivo and receptor involvement in cultured islet beta cells. *Diabetologia* 47(2), 225-39.
- [173] Ylipaasto, P., Kutlu, B., Rasilainen, S., Rasschaert, J., Salmela, K., Teerijoki, H., Korsgren, O., Lahesmaa, R., Hovi, T., Eizirik, D. L., Otonkoski, T., & Roivainen, M. (2005). Global profiling of coxsackievirus- and cytokine-induced gene expression in human pancreatic islets. *Diabetologia* 48(8), 1510-22.
- [174] Yoon, J. W., Onodera, T., & Notkins, A. L. (1978). Virus-induced diabetes mellitus. XV. Beta cell damage and insulin-dependent hyperglycemia in mice infected with coxsackie virus B4. *J Exp Med.* 148(4), 1068-80.
- [175] Yoon, J. W., Austin, M., Onodera, T., & Notkins, A. L. (1979). Isolation of a virus from the pancreas of a child with diabetic ketoacidosis. *N Engl J Med.* 300(21), 1173-9.
- [176] Yoon, J. W., & Jun, H. S. (2006). Viruses cause type 1 diabetes in animals. *Ann N Y Acad Sci.*, 1079, 138-46.
- [177] Zanone, M. M., Favaro, E., Quadri, R., Miceli, I., Giaretta, F., Romagnoli, R., David, E., Perin, P. C., Salizzoni, M., & Camussi, G. (2010). Association of cytomegalovirus infections with recurrence of humoral and cellular autoimmunity to islet autoantigens and of type 1 diabetes in a pancreas transplanted patient. *Transpl Int.* 23(3), 333-7.
- [178] Zipris, D., Hillebrands, J. L., Welsh, R. M., Rozing, J., Xie, J. X., Mordes, J. P., Greiner, D. L., & Rossini, A. A. (2003). Infections that induce autoimmune diabetes in BBDR rats modulate CD4+CD25+ T cell populations. *J Immunol.* 170(7), 3592-602.
- [179] Zipris, D., Lien, E., Nair, A., Xie, J. X., Greiner, D. L., Mordes, J. P., & Rossini, A. A. (2007). TLR9 signaling pathways are involved in Kilham rat virus-induced autoimmune diabetes in the biobreeding diabetes-resistant rat. *J Immunol.* 178(2), 693-701.

