Micro Gas Turbine Engine: A Review

Marco Antônio Rosa do Nascimento,
Lucilene de Oliveira Rodrigues,
Eraldo Cruz dos Santos, Eli Eber Batista Gomes,
Fagner Luis Goulart Dias,
Elkin Iván Gutiérrez Velásques and
Rubén Alexis Miranda Carrillo

Additional information is available at the end of the chapter

<http://dx.doi.org/10.5772/54444>

1. Introduction

Microturbines are energy generators whose capacity ranges from 15 to 300 kW. Their basic principle comes from open cycle gas turbines, although they present several typical features, such as: variable speed, high speed operation, compact size, simple operability, easy installation, low maintenance, air bearings, low NO_x emissions and usually a recuperator (Hamilton, 2001).

Microturbines came into the automotive market between 1950 and 1970. The first microturbines were based on gas turbine designed to be used in generators of missile launching stations, aircraft and bus engines, among other commercial means of transport. The use of this equipment in the energy market increased between 1980 and 1990, when the demand for distributed generating technologies increased as well (LISS, 1999).

Distributed generation systems may prove more attractive in a competitive market to those seeking to increase reliability and gain independence by self-generating. Manufacturers of gas and liquid-fueled microturbines and advanced turbine systems have bench test results showing that they will either meet or beat current emission goals for nitrogen oxides (NOX) and other pollutants (Hamilton, 2001). Air quality regulation agencies need to account for this technological innovation. Emission control technologies and regulations for distributed generation system are not yet precisely defined. However, control technologies that could

reduce emissions from fossil-fueled components of a distributed generation system to levels similar to other traditional fossil-fueled generation equipment are already available.

Combustion processes can result in the formation of significant amounts of nitrogen dioxide (NO₂) and carbon monoxide (CO). Some manufacturers of microturbines have developed advanced combustion technologies to minimize the formation of these pollutants. They have assured low emissions levels from microturbines fueled with gaseous and liquid fuels.

2. History

In fact, the technology of microturbines is not new, as researches on this subject can be found since 1970, when the automotive industry viewed the possibility of using microturbines to replace traditional reciprocating piston engines. However, for a variety of reasons, microturbines did not achieve great success in the automotive segment. The first generation of microturbines was based on turbines originally designed for commercial applications in generating electricity for airplanes, buses, and other means of commercial transportation.

The interest in the market for stationary power spread in the mid-1980 and accelerated in the 1990s, with its reuse in the automobile market in hybrid vehicles and when demand for distributed generation increased (Liss, 1999). Currently, the operation of hybrid vehicles through a microturbine connected to an electric motor, have received special attention from some of the major car manufacturers such as Ford, and research centers (Barker, 1997).

In 1978, Allison began a project aimed at the development and construction of generating groups for military applications, driven by small gas turbines. The main results obtained during testing of these generators revealed: reduction in fuel consumption of 180 l/h to 60 l/h, compared with previous models, frequency stability of about 1%, noise levels below 90 dB and the possibility of using different fuels (diesel, gasoline, etc.). In 1981, a batch with 200 generators was delivered to the U.S. Army, and since then, more than 2,000 units have been provided to integrate the system of electricity generation for Patriot missile launchers (Patriot Systems) (Scott, 2000).

The deregulation of the electricity market in the United States began in 1978 when the Power Utility Regulatory Policy Act (PURPA) revolutionized the energy market in the United States, breaking the monopoly of the electricity generation sector, enabling the beginning of the expansion of distributed generation. Since then there has been a significant increase in the proportion of independent generation in the country and, according to a projection made in 1999 by the Gas Research Institute (GRI), this in-house production should reach 35% in 2015 (Gri, 1999).

With a new market structure, i.e., with the possibility of attracting small consumers of energy, microturbines began to be the target of intense research. Already in 1980, under the support of the Gas Research Institute, a program entitled Advanced Energy System (AES) was initiated with a view to develop a small gas turbine, with typical features of aviation turbine, rated at 50 kW and equipped with a heat recovery for a system cogen-

eration. The program was abandoned around 1990 by the Gas Research Institute, on the grounds of problems with the final cost of the product (Watts, 1999). Since then, the Gas Research Institute began to support new projects in partnership with several companies, such as the Northern Research & Engineering Energy Systems, also supporting the first efforts of Capstone Turbine Corporation (still under the name of its precursor, NoMac Energy Systems) (Gri, 1999).

Some companies in the United States, England and Sweden have recently introduced in the world market commercial units of microturbines. Among these companies are: AlliedSignal, Elliott Energy Systems, Capstone, Ingersoll-Rand Energy Systems & Power Recuperators WorksTM, Turbec, Browman Power and ABB Distributed Generation & Volvo Aero Corporation.

3. State-of-the-art microturbines

AlliedSignal microturbine has shaft configuration, works with cycle Regenerative open Brayton, its bearings are pneumatic and it has a drive direct current - alternating current (DC/AC) 50/60 Hz (the frequency is reduced from about 1,200 to 50 Hz or 60 Hz) and the compressor and turbine are the radial single stage. The heat transfer efficiency of this stainless steel regenerator is 80-90%. Besides working with diesel oil and natural gas, this microturbine can burn naphtha, methane, propane, gasoline, and synthetic gas. Its noise level is estimated at 65 dB. A commercial prototype of 75 kW was designed for a 30% efficiency and its installed cost is estimated from \$ 22,500 to 30,000 (Biasi, 1998).

Elliott Energy Systems (a subsidiary of Elliott Turbomachinery Company) has a manufacturing and assembly unit in Stuart, Florida with a production capacity of 4,000 units per year. According to Richard Sanders, executive vice president of sales and marketing, Elliott has launched two commercial prototypes: a 45 kW microturbine (TA-45 model) and another 80 kW (TA-80), and later, a 200 kW microturbine (TA-200). The TA-45 model is rated at 45 kW (Figure 1) at ISO conditions and its main difference from other manufacturers is that it has oil lubricated bearings and a system starting at 24 volts, which, according to Sanders, is unique to microturbines. The TA-80 and TA-200 microturbines models are similar to the TA-45 model. All three can generate electricity in 120/208/240V and can work with different fuels: natural gas, diesel, kerosene, alcohol, gasoline, propane, methanol and ethanol (Biasi, 1998).

The development works of the components has taken the Capstone in the 90's, build and tested a prototype of a 24 kW microturbine in 1994. And in 1996, Capstone made a project consisting of 37 prototypes for field testing. According to Biasi, 1998, Paul Craig, the President of Capstone Turbine Corporation, expected the 30-kW business model to have a cost of about \$ 500/kW (installed microturbine) and a generation cost of \$ 45-50/MWh. Figure 2 shows Capstone microturbine, model C65, which is already commercially available.



Figure 1. Elliott Energy Systems Microturbine, TA-45 model.



Figure 2. Capstone microturbine, model C65 (Capstone, 2012).

Four Honeywell Power Systems microturbines of 70 kW each were, until 2001, being tested in the Jamacha Landfill in New Hampshire - United States. The gas produced in the landfills was about 37% methane, carbon dioxide and air. The gas was cooled to about 14 °C to remove moisture and impurities and then compressed to about 550 kPa for the microturbine power. For the first 3 minutes of turbine operation, the fuel feed was carried out with propane. The system operated in parallel and exported electricity to San Diego Gas & Electric. In September 2001, Honeywell decided to stop manufacturing microturbines and uninstalled the four microturbines from the Jamacha Landfill, Figure 3. Until that time, the microturbines operated for 2000 hours, without showing degradation in performance. Then, the microturbines from Honeywell Microturbines were replaced by turbines with the same capacity from Ingersoll-Rand Power Works™, as shown in Figure 4 (Pierce, 2002).

In order to develop a new generation of microturbines, in 1998 ABB Distributed Generation established a 50/50 joint venture with Volvo Aero Corporation. This partnership joined the experience of Volvo gas turbine for hybrid electric vehicles with the experience of ABB in the generation and energy conversion at high frequency. This joint venture resulted in the development of a microturbine for cogeneration. Operating on natural gas, the MT100 microturbine generates 100 kW of electricity and 152 kW of thermal energy (hot water). As other manufacturers of microturbines, the MT100 has a frequency converter that allows the generator to operate at variable speed.

Table 1. brings is a summary of the main features of microturbine leading manufacturers.



Figure 3. Ingersoll-Rand Power Works™ installed on the Jamacha Landfill - United States.



Figure 4. Prototype Ingersoll-Rand Power Works™ installed on Jamacha Landfill - United States.

Model	Manufacturers	Power Output	Set	Total Efficiency (LHV)	Pressure Ratio	TET	Nominal Speed
		kW		%		°C	Rpm
-	AlliedSignal	75	A Shaft	30 (HHV)	3.8	871	85,000
TA 45	Elliott Energy System	45	A Shaft	30	-	871	-
TA 80	Elliott Energy System	80	A Shaft	30	-	871	68,000
TA 200	Elliott Energy System	200	A Shaft	30	-	871	43,000
C30	Capstone	30	A Shaft	28		871	96,000
C65	Capstone	65	A Shaft	29		871	85,000
C200 HP	Capstone	200	A Shaft	33		870	45,000
-	Power Works™	70	Two Shafts	30 (HHV)	3	704	-
MT 100	ABB	100	A Shaft	30	4.5	950	70,000

Table 1. Technical characteristics of leading microturbine manufacturers.

Microturbines are lower power machines with different applications than larger gas turbines, having typically the following characteristics:

- Variable rotation: the turbine variable speed is between 30,000 and 120,000 rpm depending on the manufacturer;
- High frequency electric alternator: the generator operates with a converter for AC/DC. In addition, the alternator itself is the engine starter;
- Reliability: some microturbines have already reached 25,000 hours of operation (approximately three years) including shutdown and maintenance;
- Simplicity: the generator is placed in the same turbine shaft being relatively easy to be manufactured and maintained. Moreover, it presents a great potential for inexpensive and large scale manufacturing;
- Compact: easy installation and maintenance;
- High noise levels: to reduce noise levels during operation, microturbines require a specific acoustic system;
- Air-cooled bearings: the use of air bearings avoid lubricants contamination by combustion products, prolongs the equipment useful life and reduces maintenance costs;
- Retrieve: microturbine manufacturers generally use heat recovery of exhaust gas to heat the air intake of the combustion chamber, thus achieving a thermal efficiency of 30%.

4. Configuration

Microturbines have similar set-up of small, medium and large size gas turbines, as described by Nascimento and Santos (2011), i.e., microturbines are formed by an assembly of a compressor, a combustion chamber and a turbine, as shown in the simplified scheme of Figure 5.

State-of-the-art microturbines have markedly improved in the last years. Several microturbines have been developed by manufacturers with different configurations. Their configuration depends on the application, although they usually consist of a single-shaft microturbine, annular combustor, single stage radial flow compressor and expander, and a recuperator or not. The optimum microturbine rotational speeds at typical power ratings are between 60 to 90,000 rpm and pressure ratio of 3 or 4 : 1, in a single stage.

Gas microturbines have the same basic operation principle as open cycle gas turbines (Brayton open cycle). Figure 5 shows the Brayton open cycle. In this cycle the air is compressed by the compressor, going through the combustion chamber where it receives energy from the fuel and thus raising its temperature. Leaving the combustion chamber, the high temperature working fluid is directed to the turbine, where it is expanded by supplying power to the compressor and for the electric generator or other equipment available.

Microturbines are a technology based cycle with or without recuperation. To produce an acceptable efficiency, the heat in the turbine exhaust system must be partially recovered and used to preheat the turbine air supply before it enters the combustor, using an air-to-air heat exchanger called recuperator or regenerator. This allows the net cycle efficiency to be increased to as much as 30% while the average net efficiency of unrecovered microturbines is 17 % (Rodgers et. al., 2001a).

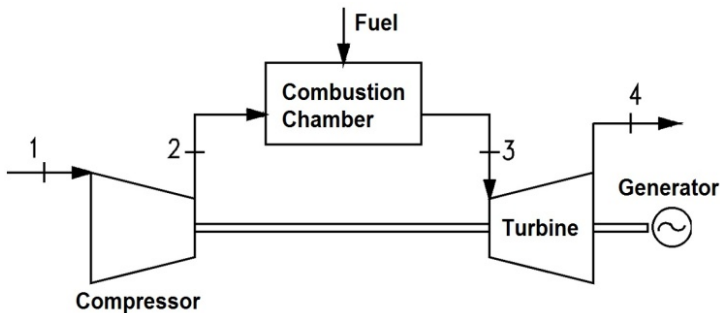

Figure 5. Gas turbine system scheme of a simple open cycle.

As well as in gas turbines, the maximum net power provided by a microturbine is limited by the temperature the material of the turbine can support, associated with the cooling technology and service life required. The two main factors affecting the performance of microturbines are: components efficiency and gases temperature at the turbine inlet.

Furthermore, microturbines usually employ permanent magnet variable-speed alternators generating very high frequency alternating current which must be first rectified and then converted to AC to match the required supply frequency.

Capstone Microturbines, shown in Figure 6, uses a lean premix combustion system to achieve low emissions levels at a full power range. Lean premix operation requires operating at high air-fuel ratio within the primary combustion zone. The large amount of air is thoroughly mixed with fuel before combustion. This premixing of air and fuel enables clean combustion to occur at a relatively low temperature. Injectors control the air-fuel ratio and the air-fuel mixture in the primary zone to ensure that the optimal temperature is achieved for the NO_x minimization. The higher air-fuel ratio results in a lower flame temperature, which leads to lower NO_x levels. In order to achieve low levels of CO and Hydrocarbons simultaneously with low NO_x levels, the air-fuel mixture is retained in the combustion chamber for a relatively long period. This process allows for a more complete combustion of CO and Hydrocarbons (Capstone, 2000).

In addition, the exhaust of microturbines can be used in direct heating or as an air pre-heater for downstream burners, once it has a high concentration of oxygen. Clean burning combustion is the key to both low emissions and highly durable recuperator designs.

The most effective fuel to minimize emissions is clearly natural gas. Natural gas is also the fuel choice for small businesses. Usually the natural gas requires compression to the ambient pressure at the compressor inlet of the microturbine. The compressor outlet pressure is nominally three to four atmospheres.

Capstone microturbine control and power electronic systems allow for different operation modes, such as: grid connect, stand-alone, dual mode and multiple units for potentially enhanced reliability, operating with gas, liquid fuels and biogas. In grid connect, the system follows the voltage and the frequency from the grid. Grid connect applications include base load, peak shaving and load following. One of the key aspects of a grid connect system is that the synchronization and the protective relay functions required to reliably and safely interconnect with the grid can be integrated directly into the microturbine control and power electronic systems. This capability eliminates the need for very expensive and cumbersome external equipment needed in conventional generation technologies (Rodgers et. al., 2001a). In the stand-alone mode, the system behaves as an independent voltage source and supplies the current demanded by the load. Capstone microturbine when equipped with the stand-alone option includes a large battery used for unassisted black start of the turbine engine and for transient electrical load management.

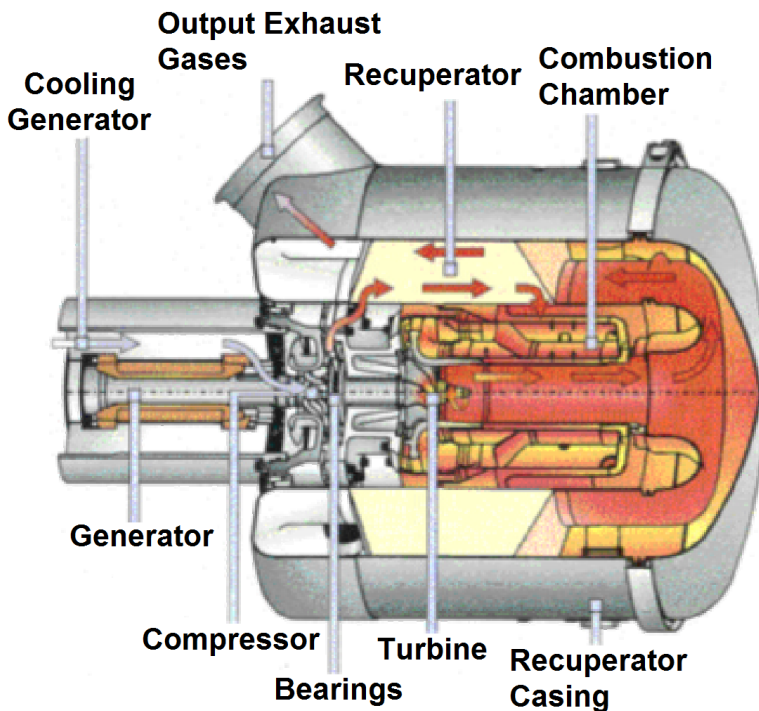

Figure 6. Parts of a Capstone microturbine.

In both operational mode, that is, the grid connect and the stand-alone, the microturbine can also be designed to automatically switch between these two modes. This type of functionality is extremely useful in a wide variety of applications, and is commonly referred to as dual mode operation. Besides, the microturbines can be configured to operate in parallel with other distributed generation systems in order to obtain a larger power generation system. This capability can be built directly into the system and does not require the use of any external synchronizing equipment.

Some microturbines can operate with different fuels. The flexibility and the adaptability enabled by digital control software allow this to happen with no significant changes to the hardware. Power generation systems create large amounts of heat in the process of converting fuel into electricity. For the average utility-size power plant, more than two-thirds of the energy content of the input fuel is converted into heat. Conventional power plants discard this waste heat, however, distributed generation technologies, due to their load-appropriate size and siting, enable this heat to be recovered. Cogeneration systems can produce heat and electricity at or near the load side. Cogeneration plants usually have up to 85% of efficiency and operation cost lower than other applications. Small cogeneration systems usually use reciprocating engines although microturbines have showed to be a good option for this application. The hot exhaust gas from microturbines is available for cogeneration applications. Recovered heat can be used for hot water heating or low-pressure steam applications.

5. Experimental set-up for microturbine

To perform tests in microturbines, a test bench was built in the Laboratory of Gas Turbines and Gasification of the Institute of Mechanical Engineering, Federal University of Itajubá - IEM/UNIFEI. This bench was composed of a 30 kW regenerative cycle diesel single shaft gas microturbine engine with annular combustion chamber and radial turbomachineries, as shown in Figure 7, and was configured to operate with liquid fuel.

The microturbine engine was tested while in operation with automotive ethanol and pure diesel, respectively. Thermal and electrical parameters, such as mass flows, temperature, composition of exhaust gases and generated power were constantly measured during the tests.

Figure 8 shows the scheme of the microturbine with the measuring points. The microturbine engine was tested during operation with ethanol and diesel at steady state condition and at partial, medium and full loads.

As can be seen in Figure 8, all parameters assessed, during laboratory tests, were acquired and post-processed in a supervisory system developed in the laboratory UNIFEI.

In order to establish whether the fuels were able to feed the engine without presenting any problems regarding the fuel injection system, the kinematic viscosity of each fuel was measured. The composition of the emission gases and the thermal variables were also measured at medium and full loads for each fuel, and their results are presented below. All tests were performed in the grid connection mode.



Figure 7. Capstone microturbine in the laboratory at UNIFEI.

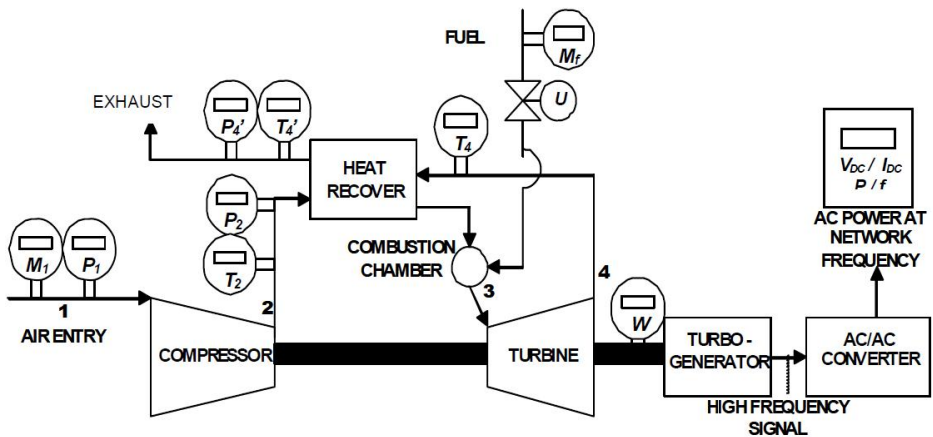

Figure 8. Schematic representation of the test rig and the data acquisition system.

This microturbine is mainly used for primer power generation or emergency and can work with a variety of liquid fuels. This microturbine uses a recovery cycle to improve its efficiency during operation, due to a relatively low pressure, what facilitates the use of a single shaft radial compression and expansion [Cohen, *et. al.*, (1996), Capstone, (2001), Roger, *et. al.*, (2001b), Bolszo (2009)]. Table 2 shows the engine design characteristics at ISO condition.

Fuel Pressure	350 kPa
Power Output	29 kW NET (± 1)
Thermal Efficiency	26% (± 2)
Fuel HHV	45,144 kJ/kg
Fuel Flow	12 l/h
Exhaust Temperature	260 °C
Inlet Air Flow	16 Nm ³ /min
Rotational Speed	96000 rpm
Pressure Ratio	4

Table 2. Engine Performance data at ISO Condition.

For tracking and measuring the tests parameters a type of supervisory software was used in the test bench (given by the turbine manufacturer) along with the data acquisition and the post processing obtained during the tests.

The composition of the exhaust gases was measured in real time using an Ecoline 6000 gas analyzer, reporting the concentration of O₂, CO₂ and hydrocarbons (HC) in volume percentage (%v/v) and NO, CO, NO₂ and SO₂ (ppm) (Sierra, 2008). The fuel high heating value (HHV) was determined by a C-2000 IKA WORKS calorimeter. The accuracy, range and resolution of each instrument used during the tests are shown in Table 3.

Instrument	Range	Resolution	Accuracy
Fuel Flow	0-100 (l/h)	1.0 (ml)	± 1.0 (%) scale
Temperature	0-350 (°C)	0.31 (°C)	± 0.8 (%) scale
Pressure	0-10 (bar)	0.01 (bar)	± 1.0 (%) scale
Power	0-45 (kW)	0.05 (kW)	± 0.5 (%) scale
Calorimeter	--	--	± 0.5 (%)
Gas Analyzer	CO (ppm)	0 - 20000	$\pm 10 < 300$
			± 4 (%) rdg < 2000
			± 10 (%) rdg ≥ 2000
Gas Analyzer	NOx (ppm)	0 - 4000	$\pm 5 < 100$
			± 4 (%) rdg < 3000

Table 3. Accuracy of the measuring instruments.

5.1. Adjustments to the microturbine

Due to impurities in the gas or fuel, for instance, in the synthesis or biofuel, a redesign of the gas turbine combustor was necessary. For each type of fuel, a different kind of optimization was needed, in relation to the fuel low heating value (LHV).

To compensate for the lower heating value (LHV) of fuel gases, the fuel injection system must provide a much higher fuel rate than when operating with high heating values. Due to the high rate of mass flow of gas with LHV, the passage of fuel has a much larger cross section than the section corresponding to natural gas. Fuel pipes, control valves and stop valves have larger diameters and shall be designed to include an additional fuel blend, which consists of the final mixture of the recovered gas with natural gas and steam. The pressure drops and the size of the air spiral entering the flame tube must be adjusted to optimize the combustion process. The system must have high safety standards, so the flanges and the gaskets of the combustor and its connections must be safely welded. The system for low LHV must include:

- Fuel line for a LHV;
- Natural gas line;
- Steam line to reduce NO_x ;
- Line blending of fuel for LHV;
- Line of nitrogen to purge;
- Lines pilot;
- Compressor;
- Combustion Chamber.

For safety reasons, the loading of the gas turbine to the rated load is accomplished through the use of the fuel reserve. The procedure for replacing the fuel reserve to the main tank is done automatically.

5.2. Tests on gas turbine using liquid fuel

The performance of a gas turbine is related to the local conditions of the installation and the environment, where pressure and temperature conditions are of great importance.

Due to the diesel low solubility at low temperature, tests with ethanol were performed without premix, and without the use of additives, which increased the cost of fuel.

According to the measuring methodology to be adopted to test gas turbines operating on liquids fuels, the physical-chemical properties of ethanol and diesel are shown in Table 4.

Table 4 also shows the fuel requirements established by the manufacturer of the tested gas turbine along with ASTM D6751 standard specifications for the testing of thermal performance. Regarding emissions a standard ISO 11042-1:1996 was used (NWAFOR, 2004).

Properties	Ethanol	Diesel	Fuel Limits	ASTM D6751
Sulfur (% mass)	0	0.20	0.05 <	< 0.05
Kinematic Viscosity @40 °C (mm ² /s)	1.08	1.54	1.9 – 4.1	1.9 – 6
Density @ 25 °C (g/cm ³)	0.786	0.838	0.75 – 0.95	-
Flash Point (°C)	13	60	38 - 66	"/> 130
Water (% Volume)	0.05	0.05	0.05	0.05
LHV (kJ/kg)	23,985.00	42,179.27		

Table 4. Ethanol and diesel physical-chemical characteristics.

The experimental determination of the ethanol heating value, kinematic viscosity and density were carried out according to ISO 1928-1976 and ASTM D1989-91 standards (ASME, 1997).

The use of different fuels implies the need of mass flow rate adjustments, according to its LHV and density, as without these adjustments, once established a load, the supply system would feed a quantity of fuel depending on the characteristics of the standard fuel (diesel). If the LHV of the new fuel is lower than standard, the gas turbine power could not reach the required demand.

Initially, the engine operated with conventional diesel fuel for a period of 20 minutes to reach a steady state condition for a load of 10 kW. After 20 minutes, the mass flow rates were changed to the fuel corresponding values. At this stage the fuel started to be replaced in order to increase the content of ethanol, by closing the diesel inlet valve and opening the ethanol valve. In order to ensure that all existing diesel power on the engine internal circuitry would be consumed, the engine was left running for 10 minutes with the same load operation, that is, 10 kW.

In order to check if the fuels were able to supply the engine, without causing problems to the fuel injection system, the kinematic viscosity of each fuel was measured. The composition of gas emissions and thermal parameters were also measured in total and average load for each fuel. This whole procedure was performed for the engine operating with loads of 5, 10, 15, 20, 25 and 30 kW in a grid connection mode.

Afterwards the emissions were measured with a gas analyzer, and the load of 5 kW increased. Ten minutes were necessary until it reached steady state again. Exhaust emissions were measured from the exhaust gases and, as mentioned before, the thermal performance data were stored in a personal computer (PC) unit coupled with a PLC (Programmable Logic Controller) data acquisition system, which carried out the data reading at every second.

When tests with ethanol were over, the engine was left running, in order to accomplish the purging of the remaining fuel. After that the engine was once again operated with diesel for ten minutes, and then disconnected and stopped.

6. Performance evaluation

The performance showed in this study was obtained from experimental tests at the Gas Turbine Laboratory of the Federal University of Itajubá (GOMES, 2002). Both natural gas and liquid fuel Capstone microturbines and their respective fuel supplying and electrical connection systems were installed and a property measurement was used to obtain the behavior of microturbines operating at partial and full load.

6.1. Natural gas

The microturbine tested on natural gas was a Capstone 330 High Pressure. Table 5 gives the technical information of this machine and the features of the natural gas used in the tests. The natural gas microturbine was tested on the stand-alone mode supplying a resistive load. These microturbines can record operational parameters (temperatures, pressures, fuel usage, turbine speed, internal voltages/currents, status, and many others). Such data can be accessed with a computer or modem connected to an RS-232 port on the microturbine. To supplement these data, additional instrumentation was installed for the tests.

CAPSTONE Microturbine Features		
Model	330 (High Pressure)	
Full-Load Power (ISO Conditions)	30 kW	
Fuel	Natural Gas	
Fuel Pressure	358 – 379 kPa	
Fuel Flow*	12 m ³ /h	
Efficiency (LHV)*	27%	
Proprieties of Natural Gas (20 °C and 1 atm)		
Specific Mass	0.6165	
Low Heat Value	36,145	kJ/m ³
High Heat Value	40,025	kJ/m ³
Ambient Conditions		
Elevation	800	meters
Average Temperature	30	°C

Table 5. General conditions of the analysis

A large battery started the microturbine when disconnected from the grid, preventing any sudden load increase or decrease in the electrical buffer during the stand-alone operation (Capstone, 2001). The start-up took about 2 minutes and the speed was increased from 0 (zero) to 45,000 rpm, occasion when the microturbine started generating electricity. The ro-

tating components of the microturbine were mounted on a single shaft supported by air bearings and a spin at up 96,000 rpm. Figure 9 shows the speed behavior with the microturbine power output.

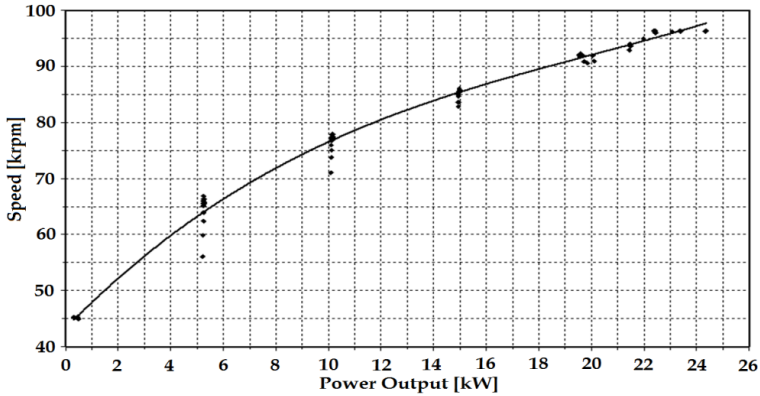

Figure 9. Microturbine speed at partial loads.

Capstone microturbine includes a recuperator which allows the microturbine efficiency to be improved. Figure 10 and 11 show respectively, the exhaust temperature and the efficiency behavior at partial loads. 27 % efficiency is possible at full load.

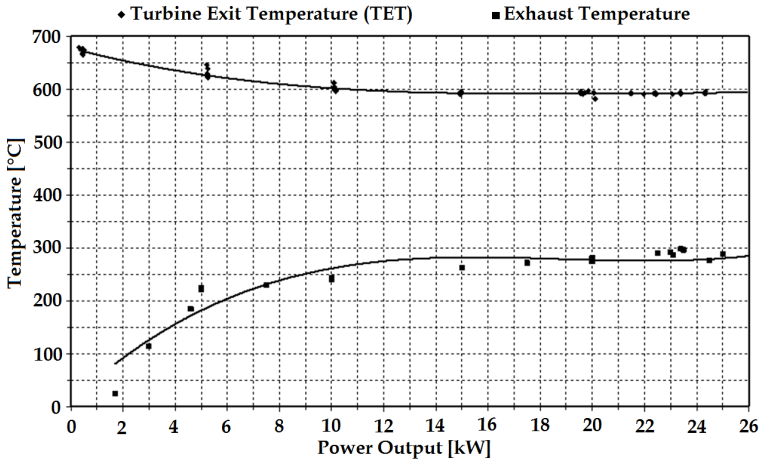

Figure 10. Microturbines exhaust temperature at partial loads.

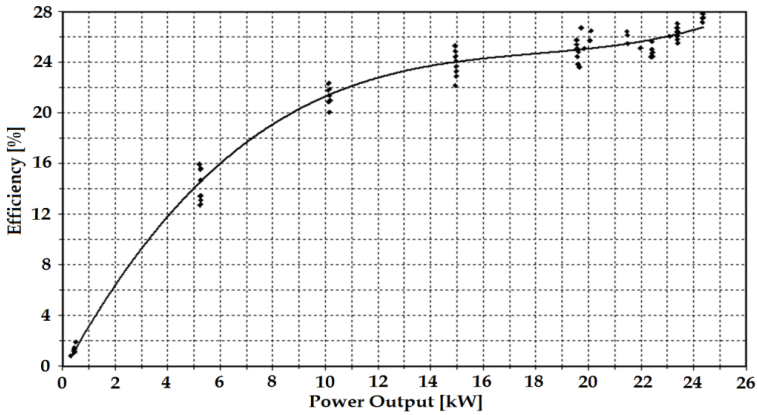

Figure 11. Microturbine efficiency at partial loads.

Figure 12 shows CO and NO_x emissions behavior of a Capstone natural gas microturbine. Combustion occurs in three different steps. The first step is from start-up to about 5 kW. At this step CO formation decreases and emissions of NO_x increase quickly.

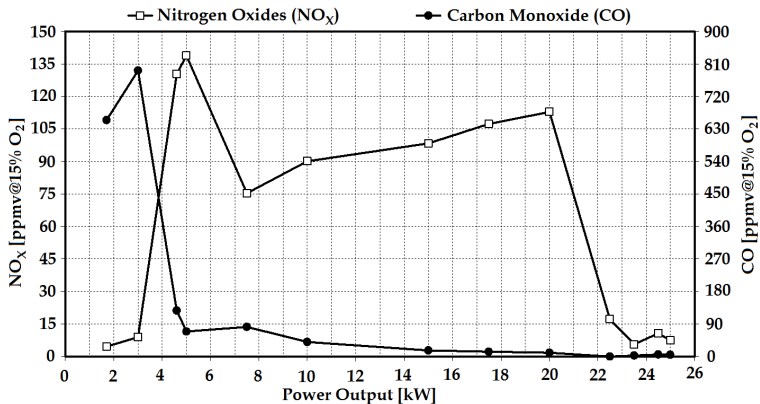

Figure 12. CO and NO_x emissions of a natural gas microturbine at partial loads.

The second step is between 5 and 20 kW, as shown in Figure 12. In the second step the CO formation decreases continuously while emissions of NO_x decrease at first, though increasing but it returns to increase softly slightly up to 113 ppmv. The last step begins at this point. At this step the lean-premix combustion occurs and the NO_x formation diminishes to 5 ppmv.

Emissions of CO₂ depend on the fuel type and the system efficiency. Figure 13 shows CO₂ emissions of a Capstone natural gas microturbine.

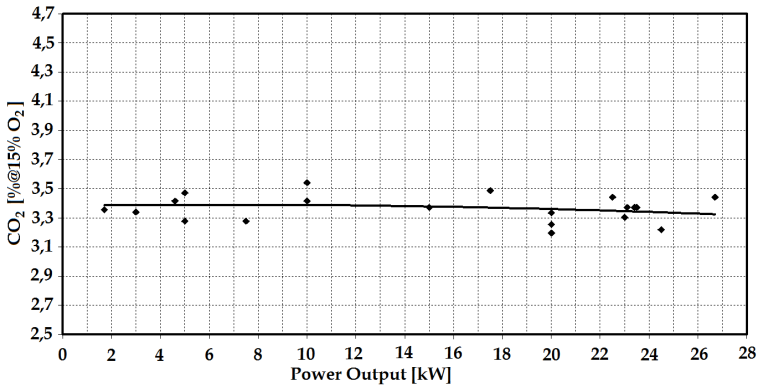

Figure 13. CO₂ emissions of a natural gas microturbine at partial loads.

6.2. Liquid fuel

The microturbine tested on diesel was a Capstone 330 Liquid Fuel. Table 6 gives the technical information of this machine and the features of the diesel used in the tests.

CAPSTONE Microturbine Features		
Model	330 (Liquid Fuel)	
Full-Load Power*	29 kW	
Fuel	Diesel #2 (ASTM D975)	
Fuel Pressure	35 – 70 kPa	
Fuel Flow*	12.5 l/h	
Efficiency (LHV)*	26%	
Proprieties of Liquid Fuel (20 °C and 1 atm)		
Specific Mass	0.848	
Low Heat Value	42,923	kJ/kg
High Heat Value	45,810	kJ/kg
Ambient Conditions		
Elevation	800	meters
Average Temperature	30	°C
* ISO Conditions		

Table 6. General conditions of the analysis

The liquid fuel microturbine was tested on the grid connect mode. These data can be accessed with a computer or modem connected to an RS-232 port on the microturbine. To supplement these data, additional instrumentation was installed for the tests. Figure 14 shows the turbine exit temperature and the exhaust temperature at partial loads. These temperatures are before and after the recuperator were used and their difference ranges from 300 to 450 °C.

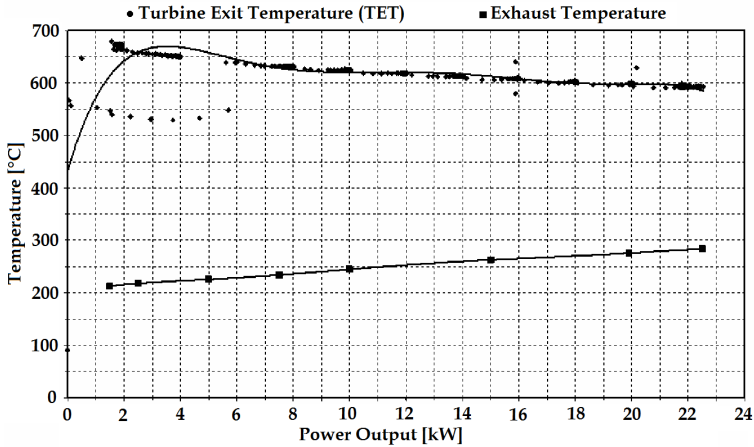

Figure 14. Microturbine exit and exhaust temperature at partial loads.

Figure 15 shows the liquid fuel microturbine efficiency at partial loads. Up to 24.5 % efficiency is possible at full load while the microturbine efficiency is at its highest when Capstone microturbines operate over an output range between 12 kW and full load.

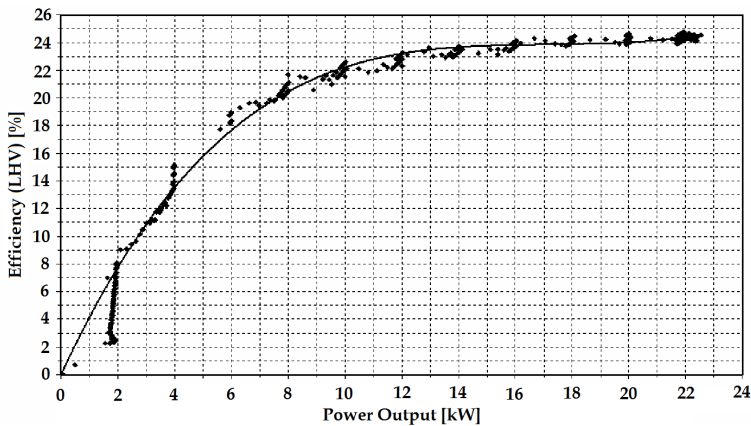

Figure 15. Microturbine efficiency at partial loads

Figure 16 shows the CO and NO_x emissions behavior of a Capstone liquid fuel microturbine. The CO formation decreases, whereas emissions of NO_x increase as the power output increases due to a rise in the flame temperature.

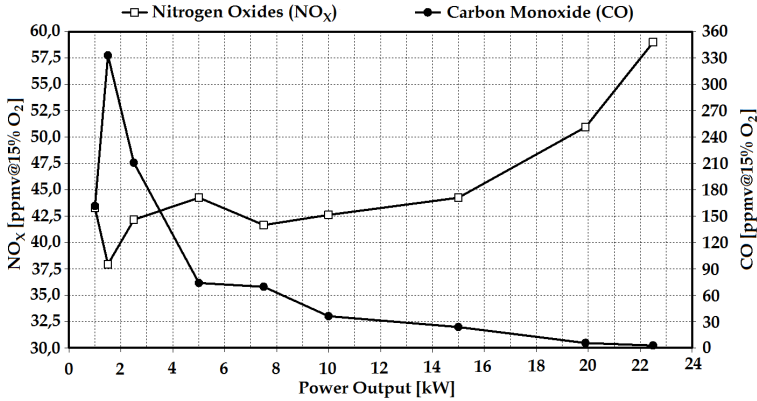

Figure 16. CO and NO_x emissions from liquid fuel microturbine at partial loads.

Figure 17 shows the CO₂ and SO₂ emissions of a Capstone liquid fuel microturbine. The emissions depend considerably on the liquid fuel features. While SO₂ emissions are an important emission category for traditional electric utility companies, they are expected to be negligible for distributed generation technologies.

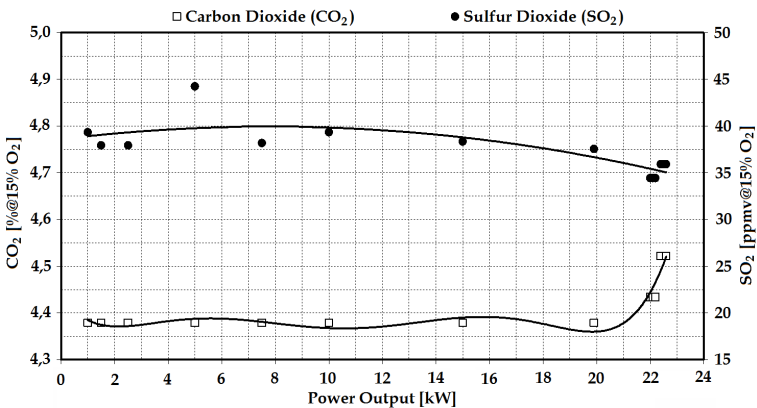

Figure 17. CO₂ and SO₂ emissions from liquid fuel microturbine at partial loads.

7. Microturbines and Internal combustion engine’s emissions

Table 7 and 8 compare emissions data from internal combustion engines and microturbines. In the absence of a post combustion device, such as a catalytic converter, reciprocating engines can have very high emission levels. Emission levels of microturbines are lower than levels of internal combustion engines as microturbines combustion is a continuous process which allows for a complete burning.

		ICE Natural Gas Without Control	ICE Natural Gas SCR	ICE Diesel Without Control	ICE Diesel SCR
Efficiency	% (HHV)	36%	29%	38%	38%
Nominal Power	kW	1,000	1,000	1,000	1,000
NO _x (@15%O ₂)	g/MWh	998	227	9,888	2,132

SCR: Selective Catalytic Reduction.

Table 7. NO_x emissions of internal combustion engines (ICE) (Weston, et. al., 2001)

FUEL		Natural Gas	Diesel
Efficiency*	% (LHV)	27	26
Nominal Power*	kW	30	29
CO (@15%O ₂)**	g/MWh	210	80
NO _x (@15%O ₂)**	g/MWh	520	280

* ISO Conditions; ** On Site Conditions (See Table 1)

Table 8. CO and NO_x emissions of Capstone microturbines

8. Case studies under Brazilian conditions

Due to the Brazilian governmental incentive to develop the gas industry, the feasibility of many natural gas applications has been doubted. Consequently, the demand for efficiently and environmentally friendly power generation technologies has increased. Many electricity consumers are considering producing their own electricity (Gomes, 2002).

This study analyses the possibility of natural gas application with Capstone microturbines in three cases of power generation: peak shaving in a small industry, base load in a gas station and a cogeneration system supplying buildings in a residential segment

Nowadays it is a trend on microturbines market to reduce investments. This paper analyses the influence of the investment cost of microturbines on the feasibility and cost of the gener-

ated electricity, being the cost of fuel a significant part of the electricity final price. The feasibility and the cost of the electricity generated with fuel were also assessed. This study used electric energy and natural gas prices charged by several electric power utility companies and gas distributors in Brazil at the time this study was being carried out (November, 2002). Table 9 shows the general conditions used in the cases studies.

Currency rate	2.6	R\$/US\$
Interest rate	10	% per year
CAPSTONE Microturbine Features		
Model	330 (High Pressure)	
Fuel	Natural Gas	
Proprieties of Natural Gas (20 °C and 1 atm)		
Specific Mass	0.602	
High Heat Value	39,304	kJ/m ³

Table 9. General conditions of the analysis

8.1. Peak shaving case

Many consumers try to reduce their electricity consumption at peak hours due to its high price. If they can produce their electricity, they will reduce the amount of electricity purchased from utility companies at peak hours, without having to reduce their electricity consumption. Besides, power generation systems can improve the quality and reliability of the energy supplied by utility companies.

A study was carried out in four Brazilian regions, classified according to the price of natural gas charged by gas distributors of these regions, as shown in Table 10. Table 11 and Figure 18 show the conditions studied and the electricity demand supplied by utility companies with and without peak shaving.

Brazilian States	
1 st Region	São Paulo (SP) and Rio de Janeiro (RJ)
2 nd Region	Ceará (CE), Pernambuco (PE) and Paraíba (PB)
3 rd Region	Rio Grande do Norte (RN)
4 th Region	Others

Table 10. Brazilian regions analyzed in the peak shaving case

Commercial microturbines available in the Brazilian market are imported from the USA and investments feasibility depends on the currency rate, as can be seen in Table 9.

Model of microturbine	Capstone 330	
Number of microturbines	1	
Life time of microturbines	20	years
Net power (peak load)	28	kW
Microturbine installed cost	1.538	US\$/kW
Natural gas consumption (HHV)	650	m ³ /month
Average price of natural gas (taxes included)	0.33-1.32	R\$/m ³

Table 11. Conditions of the peak shaving case

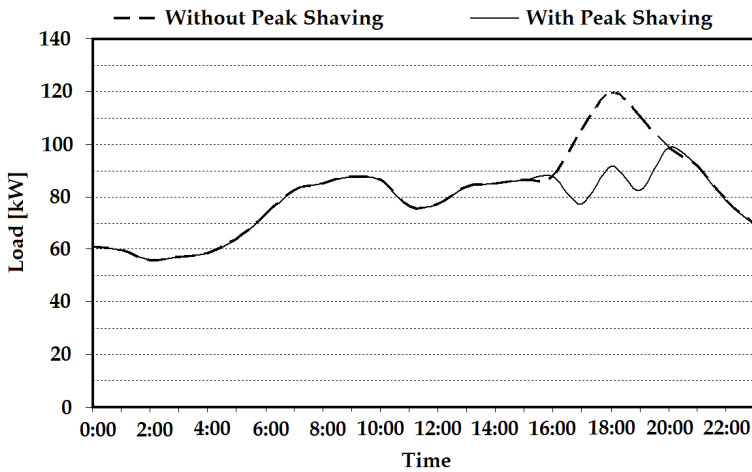

Figure 18. Electricity demand supplied by utility companies.

Table 12 displays the economical analysis of the peak shaving case. The investment is not feasible yet, as the payback period is very long. Rio Grande do Norte is the state where this business would be most interesting as payback is 8 years.

		SP - RJ	CE-PE-PB	RN	Other States
Total Investment *	US\$	46,827	46,827	46,827	46,827
Annual cost**	US\$/year	53,827	44,906	55,718	51,102
Annual cost*	US\$/year	55,323	45,231	53,950	51,479
Annual savings	US\$/year	-1,497	-325	1,769	-378
Electricity generated	US\$/MWh	435	321	301	366
Payback Period	years	32	15	8	15

* With peak shaving; ** Without peak shaving

Table 12. Economical analysis of the peak shaving case

Figure 19 shows payback period in relation to microturbine cost. There is a strong fall on the payback period of the states of SP and RJ, due to a decrease in the microturbine cost.

A few manufactures intend to decrease microturbine costs to about 400 US\$/kW until 2005 (Dunn & Flavin, 2000). If the microturbine cost is 400 US\$/kW, the payback period will be between 2.5 and 5 years, as shown in Figure 19.

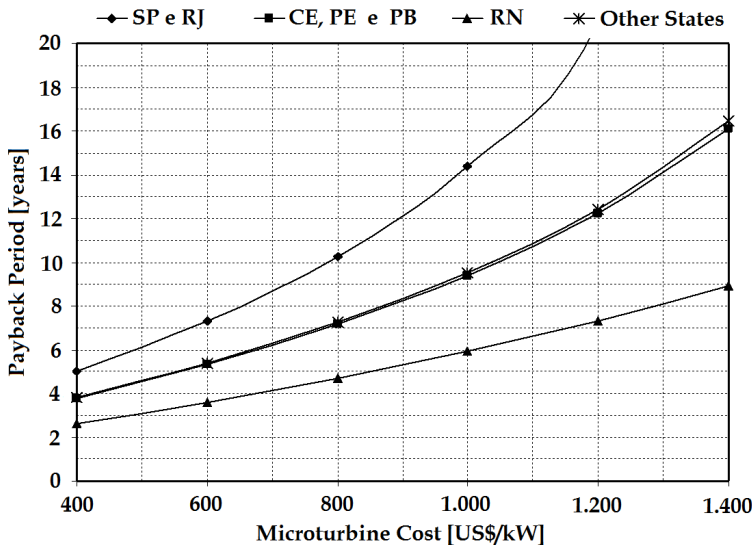

Figure 19. The influence of the microturbine cost on the return on investments.

8.2. Base load case

In this case, a microturbine produces electricity to a gas station according to the base load demand, as shows Figure 20. The conditions of this case are in table 13, whereas Table 14 shows the Brazilian regions analyzed in the base load case.

Model of microturbine	Capstone 330	
Number of microturbines	1	
Life time of microturbines	10	years
Net power	27,5	kW
Microturbine installed cost	1,538	US\$/kW
Natural gas consumption (HHV)	6,918	m ³ /month
Average price of natural gas (taxes included)	0.24 - 1.02	R\$/m ³

Table 13. Conditions of the base load case.

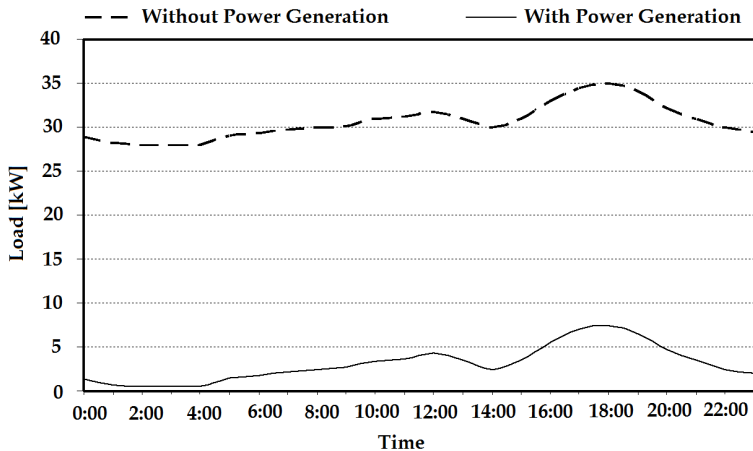

Figure 20. Electricity demand supplied by utility companies.

Brazilian States	
1 st Region	São Paulo (SP) and Rio de Janeiro (RJ)
2 nd Region	Rio Grande do Sul (RS) and Paraná (PR)
3 rd Region	Rio Grande do Norte (RN)
4 th Region	Others

Table 14. Brazilian regions analyzed in the base load case.

Table 15 displays the economical analysis of the base load case for gas stations. Up to the present moment this kind of business is not feasible, except in the state of Rio Grande do Norte (RN) where payback period can be 3.1 years, once local gas distribution companies have encouraged thermoelectric small scale power generation, according to natural gas price lower than others kind of fuels.

		SP e RJ	RS e PR	RN	Other States
Total Investment	US\$	46827	46827	46827	46827
Annual cost**	US\$/year	28748	28117	27956	24389
Annual cost*	US\$/year	45699	33898	20707	26002
Annual savings	US\$/year	- 16951	- 5780	7249	- 1614
Electricity generated	US\$/MWh	181	131	75	99
Payback Period	years	Not Feasible	Not Feasible	3,1	8,2

* With power generation; ** Without power generation

Table 15. Economical analysis of the base load case.

Figure 21 shows the behavior of the cost of the electricity generated for different micro-turbine costs and natural gas average price. Some natural gas distribution companies in Brazil have encouraged the creation of small thermal power generation units, as the cost of natural gas coming from these companies would be about 0.24 R\$/m³. Based on this fact and on the perspective of microturbine manufactures, Figure 21 shows the cost of the electricity generated could be 58 US\$/MWh. For each 1 US\$/kW decreased from the microturbine cost, the cost of the electricity generated decreases about 0,021 US\$/MWh, for every natural gas average price range, and for each 1 R\$/m³ decreased from the natural gas average price, the cost of the electricity generated decreases about 135 US\$/MWh, for every microturbine cost range.

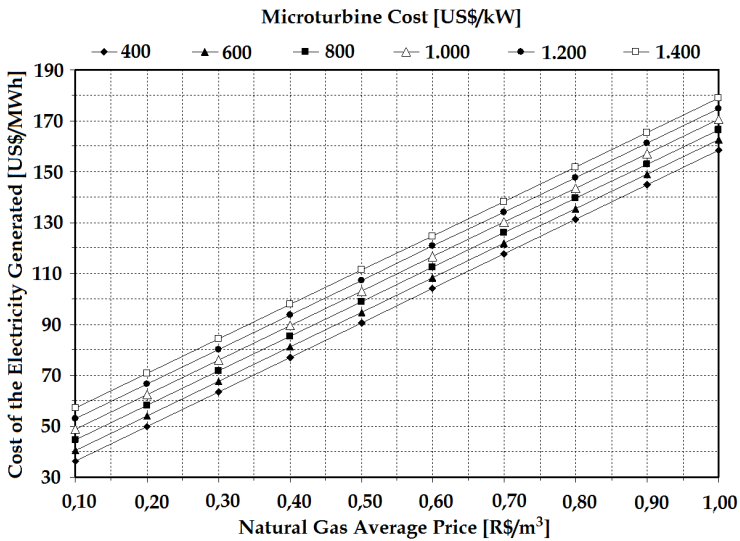

Figure 21. Cost of the electricity generated for different microturbine costs and natural gas average prices.

In the base load case, the natural gas average price is the most influential component in the return on investments. Figure 22 shows this conclusion for the microturbine cost at this moment, since natural gas average price of 0.24 R\$/m³ can result in a payback period between 3 and 4 years.

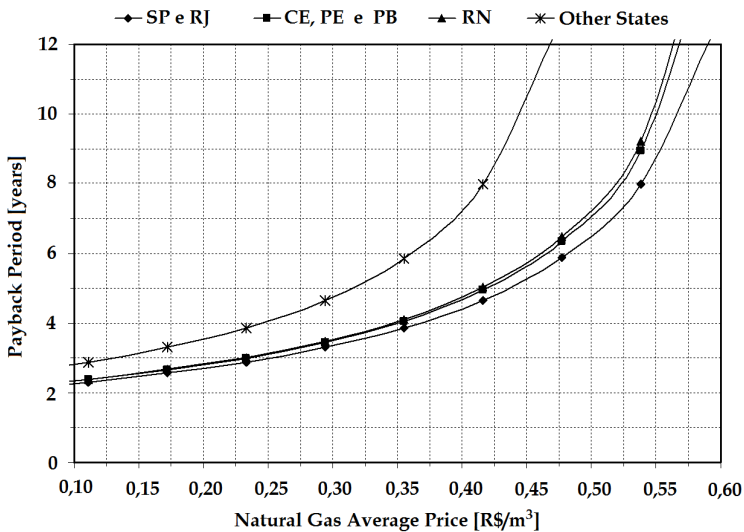

Figure 22. The natural gas average price influence on the payback period.

8.3. Cogeneration case

In this case, two microturbines and a heat recovery system produced electricity and hot water to buildings in a residential segment, according to the base load demand, as can be seen in Figure 23.

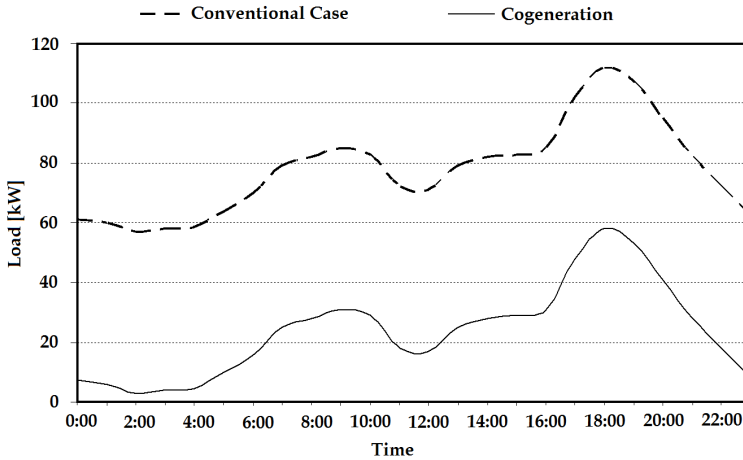

Figure 23. Electric demand supplied by utility companies to consumers with and without cogeneration.

A cogeneration plant can result in substantial savings of energy. However, these systems usually result in greater capital expenditures than non-cogeneration plants. This incremental capital investment for cogeneration must be justified by reduced annual energy costs and reduced payback periods.

A course of action involving minimum capital expenditures can be determined as the conventional case. In this study a low pressure boiler supplying process heat and the purchase of all electric power from utility system is the conventional case. Although the conventional case has the lowest investment cost, it usually has annual operating costs significantly higher than those available with cogeneration alternatives. Table 16 shows the conditions of this case, while Table 17 shows the Brazilian regions analyzed in the base load case.

System cogeneration model	MG2-C1	
Number of Capstone microturbines	2	
Number of heat recovery systems	1	
Life time of microturbines	10	years
Power output	54	kW
Heat recovery systems (hot water generation)		
Water pressure	10	bar
Water flow	2.22	t/h
Inlet water temperature	25	°C
Outlet water temperature	67	°C
Outlet exit gas temperature	93	°C
Net power	53	kW
System cogeneration installed cost	1,872	US\$/kW
Natural gas consumption (HHV)	13,653	m ³ /day
Average price of natural gas (taxes included)	0.24 - 0.90	R\$/m ³

Table 16. Conditions of the cogeneration case.

Brazilian States	
1 st Region	Rio de Janeiro (RJ)
2 nd Region	Paraná (PR)
3 rd Region	Rio Grande do Norte (RN)
4 th Region	Others

Table 17. Brazilian regions analyzed in the cogeneration case.

Table 18 displays the economical analysis of the cogeneration case. Investments costs are lower in the conventional case than in the cogeneration system, and, although the annual cost is higher, savings can be up to US\$ 24,907 per year. The payback period is between 2.8 and 3.8 years and the minimal cost of the electricity generated is 84 US\$/MWh.

		RJ	PR	RN	Other States
Total Investment*	US\$	23077	23077	23077	23077
Total Investment**	US\$	136797	136797	136797	136797
Annual cost*	US\$/year	128566	110022	90323	98328
Annual cost**	US\$/year	110337	96655	65416	77534
Annual savings	US\$/year	18228	13367	24907	20795
Electricity generated	US\$/MWh	174	146	84	112
Payback Period	years	3,3	3,8	2,8	3,1

* Conventional; ** Cogeneration

Table 18. Economical analysis of the cogeneration case.

In the cogeneration case, the fuel cost is the most influential component on the return on investment, similar to the base load case. Figure 24 shows fuel costs can represent up to 71% of the cost of the electricity generated.

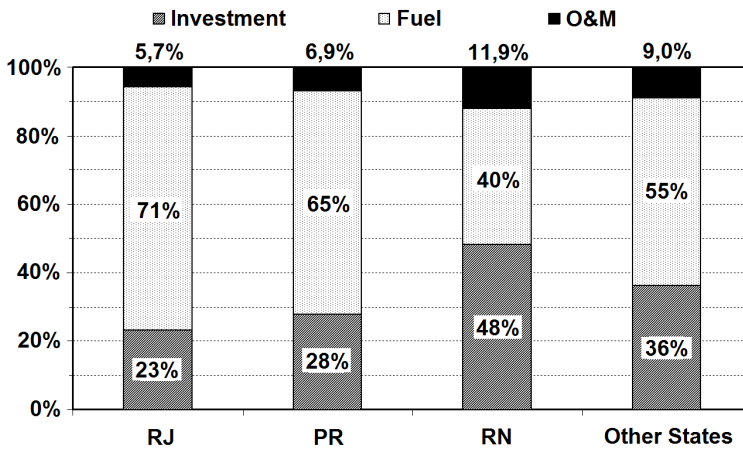

Figure 24. Components of the cost of the electricity generated.

Figure 25, Figure 26 and Figure 27 show the combined influence of microturbine cost and the average price of natural gas on the return on investment in the states of Rio de Janeiro and Paraná (Figure 25), Rio Grande do Norte (Figure 26) and the other states (Figure 27). Based on the perspective of microturbine manufactures and with natural gas average price of 0.25 R\$/m³, the payback period can be between 1.5 and 3 years.

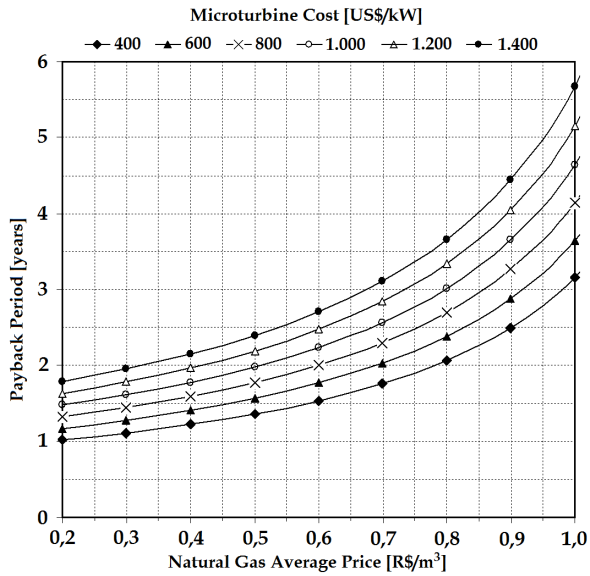

Figure 25. Combined influence of microturbine cost and average price of natural gas on the payback period in the states of Rio de Janeiro and Paraná.

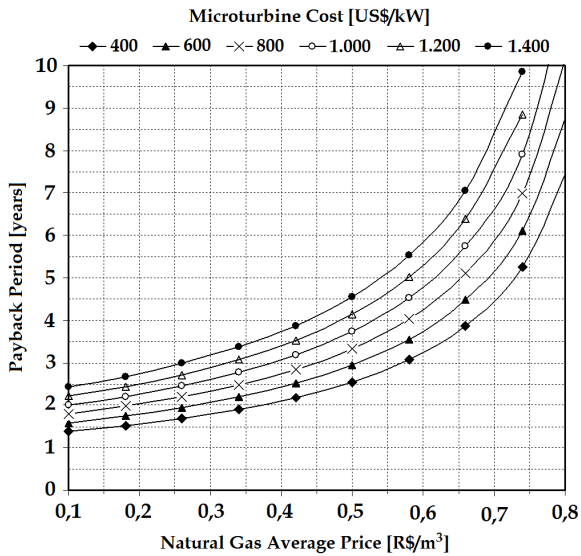

Figure 26. Combined influence of microturbine cost and average price of natural gas on the payback period in the state of Rio Grande do Norte.

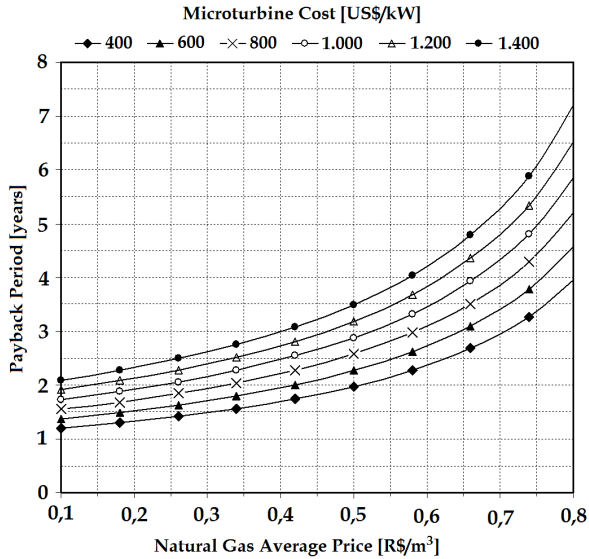

Figure 27. Combined influence of microturbine cost and average price of natural gas on the payback period in the other states.

9. Conclusions

The variable speed operation and the electric power conditioner increase part-load efficiency of microturbines as they allow for the improvement of part-load fuel savings, especially increased recuperator effectiveness at lower part-load airflows. The variable speed control improves part-load performance but requires a system able to sense load and optimize speed. According to the results shown in this study, the microturbines efficiency is at its highest when Capstone microturbines are operating over an output range between 12 kW and full load.

Capstone microturbines use clean combustion technology to achieve low emissions. Nitrogen oxides (NO_x) and carbon monoxide (CO) emission levels of these machines are lower than 7 ppmv@15%O₂ at full load when these microturbines are fueled with natural gas.

Microturbines exhibit low emissions of all classes of pollutants and have environmental benefits as they release fewer emissions compared to other distributed generation technologies, like internal combustion engines. Besides, these units are clean enough to be placed in a community with residential and commercial buildings.

Microturbine generators have shown good perspectives for electricity distributed generation in small scales, once they have high reliability and simple design (high potential for large scale cheap manufacturing).

Although results show microturbines are not feasible to provide energy at peak demand, in this case the microturbines can supply peak demand and improve the level of reliability of the electricity supplying, because they can provide stand-by capabilities should the electric grid fail.

In the base load case this sort of business is feasible just in states of Brazil where natural gas distributing companies have encouraged small thermal power generation by natural gas with lower prices, since the price is the most influential cost component of the electricity generated.

The most feasible investment in microturbines is in the cogeneration case. In this case, economical feasibility is certain in all states of Brazil as cogeneration systems can provide considerable annual savings. Besides, under the perspective of manufacturers, and with the incentive of natural gas distribution companies together with the rise in electricity prices of Brazilian utility companies, investments in microturbines for the next years will be higher than currently.

Acknowledgements

The authors would like to thank CAPES, FAPEMIG, FAPEPE and CNPq, for their financial support.

Author details

Marco Antônio Rosa do Nascimento, Lucilene de Oliveira Rodrigues,
Eraldo Cruz dos Santos, Eli Eber Batista Gomes, Fagner Luis Goulart Dias,
Elkin Iván Gutiérrez Velásques and Rubén Alexis Miranda Carrillo

Federal University of Itajubá – UNIFEL, Brazil

References

- [1] Asme performance test code PTC-22-1997, Gas turbine power plants, 1997.
- [2] Barker, T. Micros, Catalysts and Electronics, Power-Gen International 96, Turbomachinery, v. 38, n. 1, p. 19-21, 1997.
- [3] Biasi, V. de Low cost and high efficiency make 30 to 80 kW microturbines attractive, Gas Turbine World, Jan.-Feb., Southport, 1998.
- [4] Bolszo, C. D., and Mcdonell, V. G., Emissions Optmization of a Biodiesel Fired Gas Turbine, Proceedings of the Combustion Institute, 32, LSEVIER, pp. 2949-2956, 2009.

- [5] Capstone Turbine Corporation, Capstone Low Emissions Microturbine Technology, White Paper, USA, 2000.
- [6] Capstone Turbine Corporation, Capstone Microturbine Model 330 System Operation Manual, USA, 2001.
- [7] Capstone Turbine Corporation, Capstone Microturbine Product Catalog, USA, 2012: <http://www.capstoneturbine.com/prodsol/products/>, accessed at: 20/06/2012.
- [8] Cohen, H., Rogers, G. F. C., and Saravanamuttoo, H. I. H., Gas Turbine Theory, Fourth edition, 1996.
- [9] Dunn, S. & Flavin, C., Dimensionando a Microenergia. In: Estado do Mundo 2000. Brazil, UMA Ed., 2000.
- [10] Gomes, E. E. B. Análise Técnico-econômica e Experimental de Microturbinas a Gás Operando com Gás Natural e Óleo Diesel, Master Degree Thesis, Supervised by Nascimento, M. A. R. and Lora, E. E. S. Federal University of Itajubá, 2002.
- [11] Hamilton, S. L., Microturbines, Distributed Generation: a nontechnical guide, edited by Ann Chambers, cap. 3, pp. 33 – 72, PennWell Corporation, USA, 2001
- [12] GRI - Gas Research Institute, The role of Distributed Generation in competitive energy markets, Distributed Generation Forum, Gas Research Institute (GRI), 1999.
- [13] Liss, W.E., Natural Gas Power Systems for the Distributed Generation Market. Power-Gen International '99 Conference. CD-Rom. New Orleans, Louisiana, USA, 1999.
- [14] Nascimento, M. A. R.; Santos, E. C., Biofuel and Gas Turbine Engines, Advances in Gas Turbine Technology, InTech, ISBN 978-953-307-611-9, chapter 6, 2011.
- [15] Nwafor, O., Emission characteristics of Diesel engine operating on rapeseed methyl ester. Renewable Energy, 29, pp. 119-29, 2004.
- [16] Pierce, J. L. Microturbine Distributed Generation Using Conventional and Waste Fuel, Cogeneration and On-Site Power Production, James & James Science Publishers, p. 45, v. 3, Issue 1, Jan-Feb, 2002.
- [17] Rodgers, C.; Watts, J.; Thoren, D.; Nichols, K. & Brent, R. Microturbines, Distributed Generation – The Power Paradigm for the New Millennium, edited by Anne-Marie Borbely & Jan F. Kreider, cap. 5, pp. 120 – 148, CRC Press LLC. USA, 2001a.
- [18] Rodgers, G., and Saravanamuttoo, H., Gas Turbine Theory, Prentice Hall, 2001b.
- [19] Scott, W. G. Micro Gas Turbine Cogeneration Applications, International Power and Light Co., USA, 2000.
- [20] Sierra, R. G. A., Teste Experimental e Análise Técnico-Econômica do Uso de Biocombustíveis em uma Microturbina a Gás de Tipo Regenerativo; Dissertação de Mestrado, UNIFEI, 2008.

- [21] Watts, J. H, Microturbines: a new class of gas turbine engine, *Global Gas turbine News, ASME-IGTI*, v. 39, n. 1, p. 4-8, USA, 1999.
- [22] Weston, F., Seidman, N., L., James, C. Model Regulations for the Output of Specified Air Emissions from Smaller-Scale Electric Generation Resources, *The Regulatory Assistance Project*, 2001.

