Calculus Elements for Mechanical Presses in Oil Industry

Biris Sorin-Stefan, Mariana Ionescu,
Gheorghe Voicu, Nicoleta Ungureanu and
Valentin Vladut

Additional information is available at the end of the chapter

<http://dx.doi.org/10.5772/53167>

1. Introduction

Oil products industry produces edible and inedible oils. About 2/3 of total oil products are the edible oils, which are used directly in foods or in the manufacture of margarine, mayonnaise, bakery and pastry products, cooking fats, preserves etc. The remaining 1/3 of the total volume of produced oil are the technical oils, used in the production of various products, such as: detergents, paint, glycerin, fatty acids, varnish, pharmaceuticals or cosmetics (Banu, 1999).

Vegetable oils are one of the oldest classes of known chemical compounds. There are multiple references and clues on the use of these oils during Stone Age and Bronze Age (Willems, 2007).

Raw material for vegetable oil industry are oilseeds, an important component of modern agriculture. Oilseeds provide easily highly nutritious human food and oil crops and their products represent one of the most important commerce commodity. Vegetable oils are a source of vitamins, calories and essential fatty acids for human diet, at a relatively low cost. After the processing of oilseeds remains the cake, or the solid part which is a valuable source of protein for animal feeds (Bargale, 1997).

Fats are found in plant and animal tissues, and in secretions of animal body glands (i.e. in milk). Fatty matter of plants is concentrated only in seeds, kernels, germs, fruits and tubers, and they reserve substances that the plant uses as energy source. Fat content in these parts of the plant is highly variable (below 5% in most plants).

There are a wide range of raw materials for oils industry. In the vegetable reign for example are more than 100 oleaginous plants, but only 40 of them can be are used for oil expression.

The other plants are unprofitable, as they have low oil content of the seeds or as they require a difficult expression process. The most important oleaginous plants are: sunflower, soya, rape, cotton, poppy, almond, sesame, nut, palm, coconut, olive, flax, castor (Banu, 1999).

Separation of oil from oilseeds is an important processing operation. The process employed has a direct effect on the quality and quantity of protein and oil obtained from oilseeds (Bargale, 1997). The terms “expression” and “extraction” are used frequently when discussing about vegetable oil separation. Expression is the process of mechanically pressing liquid out of liquid-containing solids. Extraction is the process of separating a liquid from a liquid-solid system with the use of a solvent (Khan & Hanna, 1983). There has been some confusion in the literature between the operations of “expression” and “extraction”. The latter word has been used quite loosely to designate either operation (Gurnham & Mason, 1946). This tendency has been so extensive that the distinction between the two terms appears to be disappearing from the literature. The term “extraction” is also used for mechanical oil expression (Biris et al., 2009/a).

Worldwide, for extraction of oil from seeds, fruits and nuts, four basic methods are used, as shown in the following figure.

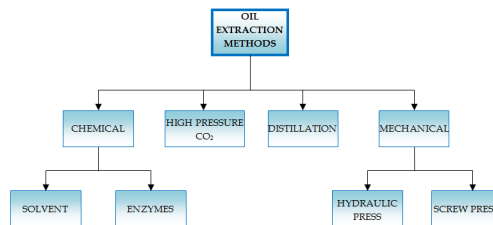

Figure 1. Oil extraction methods (Sari, 2006)

Chemical extraction method is based on the use of enzymes or solvent to extract the oil from the raw material. Solvent extraction method uses a solvent (which is, in generally, a hexane, meaning a petroleum distillate) mixed with ground seeds. Seeds are grounded to maximize the contact area of the seed with the solvent; thus the oil yield is higher. After the mixing process, the obtained mixture is heated up to 100°C to separate the oil from the solvent. The other chemical extraction, enzymatic extraction, is adopted by powerful vegetable oil companies, as the process produces many high value products. For this extraction methods, seeds are cooked and put into water. Next, enzymes are added as they digest the solid material. The basic difference of this type of extraction method from the solvent type is that the residual enzymes in the oil are separated by the use of a liquid-liquid centrifuge (Sari, 2006).

The extraction using high pressure carbon dioxide (i.e. supercritical fluid extraction, SFE) embodies several features of conventional solvent extraction, but it has important features of its own (Bulley et al., 1984). This extraction method consists in seeds mixing with a liquid form of high pressure carbon dioxide. Oil is dissolved in the carbon dioxide and when the pressure is released, the carbon dioxide becomes a gas, leaving the oil behind.

Steam distillation is the method used for the extraction of 93% from the essential oils, the rest of 7% being extracted with other method (Masango, 2005). Hot steam releases the aromatic molecules from the plant material, by forcing the open of the pockets in which the oils are kept in the plant material. The molecules of these volatile oils will exit from the plant material and evaporate into the steam. The steam mixed with the essential oil is further passed through a cooling system to condense the steam, which forms a liquid from which the essential oil and water is then separated.

The mechanical process is another method for oil extraction. Mechanical expression of oil requires the application of pressure to force oil out of the oil bearing material (Ogunsina et al., 2008). Various types of machines can be used for compression: screw presses, hydraulic presses, roll presses and mills, collapsible-plate and frame-filter presses, disc mills, interlocking-finger juice extractors, juice reamers (Khan & Hanna, 1983). From this variety of machines, there are available for expression processing two of them, the hydraulic press and screw press mechanisms. Hydraulic press, based on the principle of the hydraulic ram, originates in England and it was first patented in 1795 by Joseph Bromah (Dunning, 1953). The first screw press was developed by V.D. Anderson in the United States, in 1900. Due to the advantages it presents (continuous operation, high working capacity, run without high shocks and vibrations, working pressures which can be easily adjusted, etc.) screw presses quickly replaced hydraulic presses (Biris et al., 2009/b). In the figure below is presented a model of screw press developed by De Smet Rosedowns company, from United Kingdom.

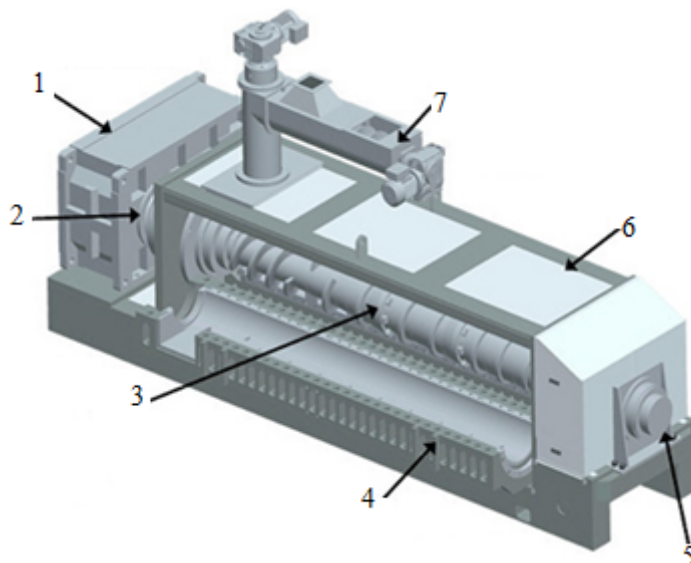

Figure 2. De Smet Rosedowns screw oil press 1 – gearbox; 2 – thrust housing; 3 – worm assembly; 4 – drainage cage; 5 – discharge end bearing; 6 – frame; 7 – feeder.

Mechanical pressing and solvent extraction are the most commonly used methods for commercial oil extraction. Oils obtained by mechanical pressing has high quality, but it can be recovered up to 90-95% of available oil. Solvent extraction has the advantage of the high yield that can be obtained (up to 99%), and as for disadvantages, oil quality is lower (Karaj & Müller, 2009). This quality reduction is produced by the extensive solvent recovery processes that are necessary and the fact that the solvent co-extracts undesired components from the cell walls (Willems et al., 2008).

Pressing technology of oleaginous material meal occurs under the influence of compression forces in mechanical presses. First, the oil from particles surface is separated – retained by surface forces of the molecular field, by the channels formed between particles. For a certain pressure, deformation and strong compression of particles begin, producing the elimination of oil from the capillars of particles. At a certain point, the space between particles gets so small that the oil film is subjected to the retaining forces exerted by particles surfaces, the oil can not be removed, the particle breaks in several places, the particle surfaces are in contact, and the briquetting begins, namely the forming of broken (cakes).

Increasing the pressure on meal particles must be done gradually, as for the harsh increase, fine meal particles will block the outler of oil from the capillaries, thus reducing the general pressing yield.

Pressing process cand be assimilated to the process of capillary filtration (fluid flow through capillary), expressed by the equation:

$$V = \frac{\pi \cdot p \cdot d \cdot t}{128 \cdot \eta \cdot l} \left[\text{m}^3 \right] \quad (1)$$

where: V – volume of separated liquid (passing through capillaries), [m³]; p – applied pressure, [N/m²]; d – diameter of cappillary channel, [m]; η - dinamic viscosity of oil, [Pa s]; l – lenght of capillary channel which must be passed by the separated oil, [m]; t – time of applied pressure, [s].

From the above equation it results that the process of oil separation can be positively influenced if the values of p , d and t are increasing and if values of l and η will decrease.

Pressure p in mechanical presses is created by an helical conveyer (worm) which rotates in a closed space (pressing chamber). Gradual increase of pressure is done by the decrease of free volume of pressing chamber from one stage to another (by increasing the shaft diameter and decreasing the chamber diameter) and by reducing the pitch of worm. Pressing force is influenced by the resistance at the exit of material from the pressing chamber, as the amterial is forced to pass through a space with variable section.

Pressing time t must be high enough to allow the proper oil flow. A prolongation of the pressing time does not lead to significant increase of oil extraction efficiency, but leads to the sensitive decrease of press productivity.

Pressing time can be determined as the sum of the pressing times in each section (compression stage) of the press:

$$t = \sum_{i=1}^n t_{si} \quad (2)$$

where: n is the number of pressing stages, and the pressing time in a certain section is given by:

$$t_s = \frac{V_{is} \cdot c_s}{Q_v \cdot (1 - \beta_s)} \quad (3)$$

where: V_{is} – volume of free space in the pressing section, [m^3]; c_s – pressing degree of meal in the respective section; Q_v – volumic feed flow of the press with meal, [m^3/s]; β_s – correction coefficient related to the quantity of meal removed from the press with the oil, until the analyzed section.

Pressing time also depends on the design and functional characteristics of the press and it ranges between 40-200 seconds. Pressing time depends on the shaft speed, cake (brocken) thickness at the press exit, and physico-chemical characteristics of the meal. Pressing time is inversely proportional to shaft speed and to cake thickness. As cake thickness is greater, the pressure in pressing chamber decreases, and pressing time decreases due to the fact that the material passes easier through the pressing chamber. At high pressure presses, by reducing the thickness of sunflower brocken from 11 mm to 4 mm the pressing time increases from 93 s to 106 s.

Parameters η , l and d are influenced by the preparation operations of meal thus:

- oil viscosity η decreases by meal heating in roasting operation;
- capillars lenght l can be lowered by advanced destruction of cellular structure by grinding and, partially, during roasting, as well as by the reduction of passing distance of oil to the outlet hole from the pressing chamber (material layer in the pressing chamber must have small thickness).

In the technological diagram of pressing followed by solvent extraction, the presses can be of various types:

- for moderate preliminary pressing, which ensure the separation of 75-80 % oil and 18-22 % remaining oil in brocken;
- for advanced preliminary pressing, which ensure 12-14 % remaining oil in brocken.

To obtain oil just by pressing, without solvent extraction, there are:

- presses with a single pressing stage, mechanical presses for final pressing, which realize separation with maximum 3-6 % remaining oil in broken;
- presses with two pressing stages, the first is used for moderate pressing, and the second stage for final pressing.

Depending on the press type, pressure applied on the meal gets to 250-280 daN/cm² – for preliminary pressing, respectively 400-2000 daN/cm² – for final or single pressing.

In Romanian oil factories, processing oleaginous seeds with high oil content is done after the diagram of pressing-extraction, so by using preliminary pressing equipments (moderate or advanced).

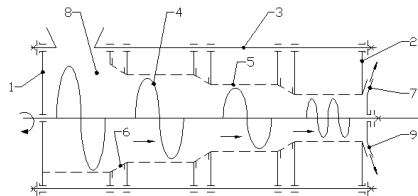

Figure 3. The operating principle of the continuous mechanical press 1 –front plate; 2 –back plate; 3 –clamping columns; 4 –screw; 5 –cylindrical strainer (barrel); 6 –tapered strainer (barrel); 7 –tapered exhaust end for pressure adjustment of pressing chamber; 8 –feed area of meal; 9 – evacuation area of cake from the pressing chamber.

Mechanical oil expression involves the release of oil from the seed interior into the interparticle voids on application of pressure. Filling of the interparticle voids leads to a buildup of pore pressure, thereby to the development of pressure gradient in the voids. As a result, oil flows through the porous medium and is finally expressed through the porous retaining envelope (Ajibola et al., 2002). The efficiency of expression is influenced by: the porosity of the cake, yield stress of the solid phase, the compressive force applied and viscosity of the expressed liquid (Clifford, 1973). The pressing process has been studied by several authors and they have found the following parameters influencing oil expression: applied pressure, moisture content, heating temperature and heating time, particle size (Adeeko & Ajibola, 1990; Khan & Hanna, 1983). Thus, increasing parameters such as heating temperature, heating time and applied pressure while reducing oilseed moisture to a certain degree will result in the increase of oil yield. A significant influence on oil yield has the postheating moisture content of some oilseeds (Ajibola et al., 1993). Effects of oilseeds heat treatment are: rupture of the oil bearing cells of the seed, coagulate the protein in the meal, adjust the moisture level of the meal to optimum level for oil expression. Lower the viscosity and increase the fluidity of the oil to be expelled and destroy mould and bacteria thereby facilitating oil expression from material (Adeeko & Ajibola, 1990). Optimum heating temperature for oilseeds is found in the range of 90-110°C for an average retention time of 20 minutes (FAO, 1989).

Oil expression is accompanied by compression and consolidation process brought about by the reduction in the volume of the compressed material (figure 4).

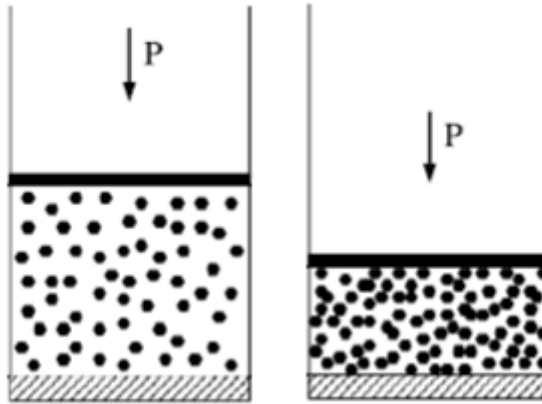

Figure 4. Volume reduction of the compressed material (Venter et al., 2007)

Thus, reduction of the total void space occurs, causing oil elimination (Sivalla et al., 1991). Value of the applied pressure at the point that oil leaves the interparticle voids is viewed as the oil point pressure, namely the minimum pressure that must be applied before oil expression begins. Applied pressures below this point are regarded as effort required to mobilize oil from the seed cells to the surface (Sukumaran & Singh, 1989; Mrema, 1979).

The general theoretical description of expression is based on consolidation theories originally developed for soil mechanics (Terzaghi, 1954). There are several studies on the modelling of oilseed expression, resulting in the development of empirical models, Terzaghi-type models and models based on the nature of the cell structure of the oilseeds (Venter, 2007).

Processes and phenomena that occur during the pressing process of oleaginous materials are very complex. This paper contains a theoretical model on the power necessary to operate an oil press. The necessary components to power the press are: the power required for material transport along the pressing chamber, the power required to press the oleaginous material, the power required to overcome the friction between the screw spire and the material, the power required to push the material from the press through the exhaust cylinder head. The paper presents some diagrams showing the influence of various constructive and functional parameters on the pressing process.

Theoretical elements of a functional calculus, and of the power necessary to operate the press are rather poor and based especially on simple formulas containing some correction coefficients, whose value is empirically obtained from experiments. This is due to the complexity of the processes and phenomena taking place during pressing, such as: material transport, proper pressing, overcoming the frictions between auger and material, pushing the material through the slot at the end of the pressing chamber.

Mechanical work for material pressing it results from the expression of the equivalent stress, which occurs in the pressing chamber after applying on the cross surface of the pressing

chamber an equivalent pressing force, so that it may be produced a reduction of the volume occupied by the material, from the initial value to the final value.

Based on the mathematical model developed in this study, was found the variation of the component parts of the power necessary for operation in the case of a press from the oil industry.

The main data taken into consideration for modelling are: the variable auger rotational speed ($n=15-40 \text{ min}^{-1}$), the variable pressure inside the pressing chamber ($p=50 \cdot 10^5-200 \cdot 10^5 \text{ Pa}$), the diameter of the pressing chamber ($D=200 \text{ mm}$), the diameter of the auger shaft ($d=100 \text{ mm}$).

The mathematical model which was created in this paper permits the high precision determination of the functional parameters and of the necessary power for operating the presses in food industry.

From the figures presented in this paper it can be observed that the necessary power for proper pressing is the highest, being followed by the necessary power for overcoming the frictions between the auger spire and the material subdued to pressing. The values for the power necessary to push the material through the exhaust space and for the material transport through the pressing chamber are much lower than those for the presses, being possible to even be neglected.

This paper can be useful to students undertaking batchelor studies, to professors and researchers in design and development of mechanical oil presses.

2. Theoretical elements

2.1. Functional calculus elements

Pressure ratio is the reduction of the material subjected to pressing and it can be calculated using equation [4], where V_i is the initial volume of the material, [m^3] and V_f is the final volume, [m^3].

$$\varepsilon = \frac{V_i - V_f}{V_i} \quad (4)$$

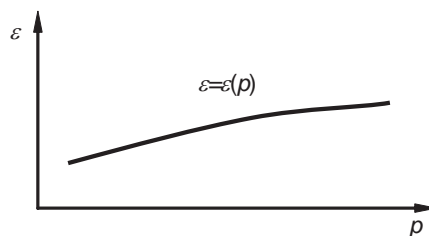

Figure 5. Variation of the pressure ratio with the pressure

The value of pressure ratio is directly proportional to the working pressure of the press, and its variation is shown in figure 5.

Press volume flow rate can be evaluated by using the relation [5]:

$$Q_v = V_{te} \cdot (1 - \varepsilon) \cdot n \cdot k \cdot 60 \quad [\text{m}^3] \quad (5)$$

where: V_{te} – is the theoretical volume of the material displaced by the auger spire during a complete rotation, in the exhaust area [cu.m.]; n – auger rotative speed, [rpm]; k – coefficient taking into account the material flowing back through the spire extremities, as well as the incomplete feed with material, ($k=0,2 \div 0,35$).

The theoretical volume of the material displaced by the auger spire is calculated using the following equation:

$$V_{te} = \frac{\pi}{4} \cdot (D^2 - d^2) \cdot (s - \delta) \quad [\text{m}^3] \quad (6)$$

where: s – the auger spire pitch [m]; δ – thickness of the auger spire, [m]; D – outer diameter of the auger spire, [m]; d – inner diameter of the auger spire (of the auger shaft), [m].

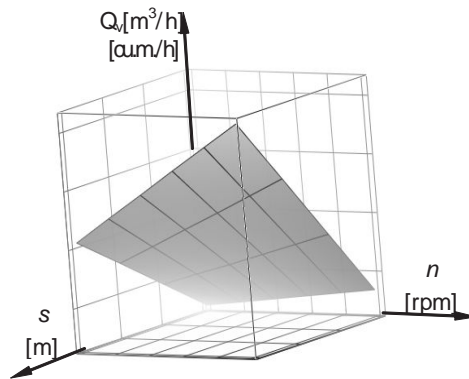

Figure 6. Variation of the press flow rate depending on the auger rotative speed and the spire pitch

By replacing in equation (5) the expression of the theoretical volume given by equation (6), it results the expression of the press volume flow rate under the form (see Figure 6):

$$Q_v = \frac{\pi}{4} \cdot (D^2 - d^2) \cdot (s - \delta) \cdot (1 - \varepsilon) \cdot n \cdot k \cdot 60 \quad [\text{m}^3/\text{h}] \quad (7)$$

2.2. Calculus of the power necessary to operate the press

- The power necessary to operate the press can be evaluated by using the equation:

$$P_p = \frac{P_{tr} + P_{pres} + P_{fr} + P_{cap}}{\eta_{tm}} \quad [\text{kW}] \quad (8)$$

where: P_{tr} – represents the necessary power to transport the material from feeding chamber to exhaust head, [kW]; P_{pres} – necessary power for pressing the material, [kW]; P_{fr} – necessary power for overcoming the frictions between the auger spire and the material, [kW]; P_{cap} – necessary power for pushing the material through the exhaust space in the press, [kW]; η_{tm} – mechanical transmission yield (output).

- Necessary power for material transport

Taking into account the calculus equations of the slow helical conveyors, it can be written the expression of the necessary power for proper transport of the material along the auger:

$$P_{tr} = \frac{F_r \cdot v}{1000} \quad [\text{kW}] \quad (9)$$

where: F_r – represents the resistant force to the material advancing along the press auger, [N]; v – mean speed by which the material moves along the press auger, [m/s].

The resistant force F_r is given, on one part, by the phenomenon of outer friction between the material and the walls of the pressing chamber, and, on the other part, by the phenomenon of outer friction of the material subdued to pressing. The value of this force can be calculated by the expression:

$$F_r = q \cdot l \cdot g \quad [\text{N}] \quad (10)$$

where: g – represents the gravity acceleration, [m/sq.s]; q – the linear load (mass per linear meter of material) in the press, [kg/m]; l – length of pressing chamber, [m].

The expression of the linear load, q , can be written:

$$q = S \cdot \psi \cdot \gamma = \frac{\pi \cdot (D^2 - d^2)}{4} \cdot \psi \cdot \gamma \quad [\text{kg/m}] \quad (11)$$

where: ψ – represents the coefficient of admission for the press section; S – area of the cross section of the pressing chamber, [sq.m.].

By replacing into the relation (10) it results:

$$F_r = \frac{\pi \cdot (D^2 - d^2)}{4} \cdot \Psi \cdot \gamma \cdot l \cdot g \quad [\text{N}] \quad (12)$$

It results the necessary power for transporting the material along the pressing chamber:

$$P_{tr} = \frac{F_r \cdot v}{1000} = \frac{\pi \cdot (D^2 - d^2) \cdot \Psi \cdot \gamma \cdot l \cdot g \cdot v}{4 \cdot 1000} = \frac{\pi \cdot (D^2 - d^2) \cdot \Psi \cdot \gamma \cdot l \cdot g \cdot s \cdot n}{4 \cdot 1000 \cdot 60} \quad [\text{kW}] \quad (13)$$

- Necessary power for pressing the material

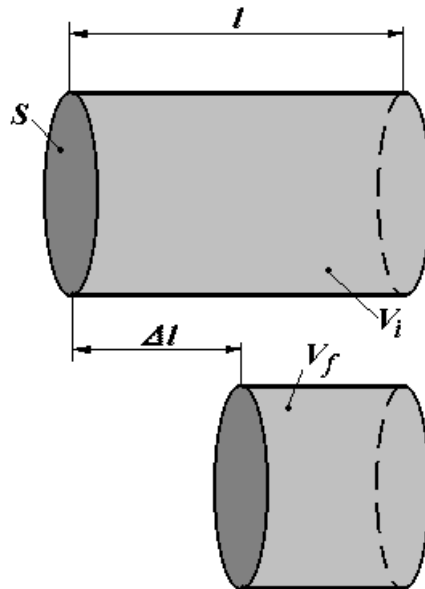

Figure 7. Variation of the material volume in the pressing process

The mechanical work for material pressing (L_{pres}) results from the expression of the equivalent tension (stress) σ , which appears inside the pressing chamber as a result of applying on the cross surface (S) of the pressing chamber an equivalent pressing force (F_{pres}), so that it may be produced a reduction of the volume occupied by the material, from the initial value, V_i to the final value, V_f , as it is also shown in figure 7. Hence, the equivalent tension (stress) in the pressing chamber can be written as:

$$\sigma = \frac{F_{pres}}{S} = \frac{F_{pres} \cdot \Delta l}{S \cdot \Delta l} = \frac{L_{pres}}{\Delta V} = \frac{L_{pres}}{V_i - V_f} \quad [\text{Pa}] \quad (14)$$

Taking into account equation (4), it results:

$$V_f = V_i \cdot (1 - \varepsilon) \quad (15)$$

and from the equations (14) and (15) is obtained the expression of the mechanical work for the material pressing:

$$L_{pres} = \sigma \cdot (V_i - V_f) = \sigma \cdot [V_i - V_i \cdot (1 - \varepsilon)] = \sigma \cdot \varepsilon \cdot V_i \quad [\text{J}] \quad (16)$$

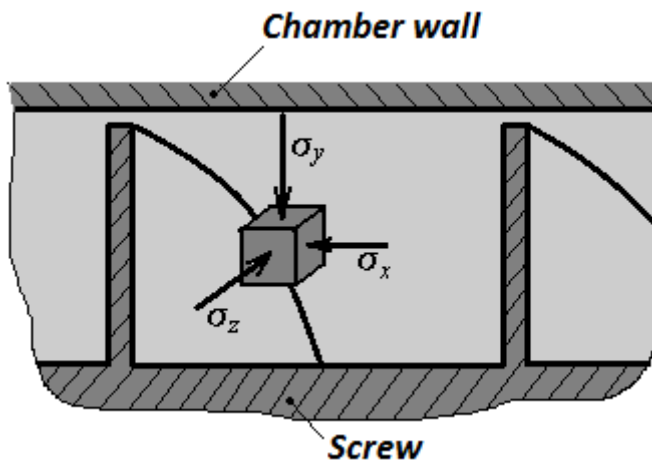

Figure 8. Elementary volume of material subdued to the pressing process

To determine the value of equivalent tension (stress) σ , it is considered an elementary volume of material subjected to pressing, uniformly loaded on each section, as shown in figure 8, which, during the pressing process will move only on the longitudinal direction of the press (direction x). Under these conditions it can be written:

$$\begin{cases} \sigma_y = \sigma_z \\ \sigma_x = p \end{cases} \quad (17)$$

where: p [Pa] - represents the pressure performed by the auger, which is exerted on the material.

It is considered that the tensions (stresses) on the direction y and z occur due to the pressure oriented to the direction of material displacement, respectively:

$$\sigma_y = \sigma_z = \beta \cdot \sigma_x \quad (18)$$

where: β - represents the coefficient of the side pressure.

Taking into account equation (18), it results:

$$\sigma_x + \sigma_y + \sigma_z = p \cdot (1 + 2 \cdot \beta) \quad (19)$$

As the materials subjected to the pressing process in the food industry also contains a certain percentage of liquid substance (oil, must, etc.), it can be considered that the hydrostatic pressure law remains valid, respectively:

$$\sigma = \frac{\sigma_x + \sigma_y + \sigma_z}{3} = \frac{p \cdot (1 + 2 \cdot \beta)}{3} \quad (20)$$

Thus, it results the expression of the mechanical work necessary for pressing the material:

$$L_{pres} = \frac{1 + 2 \cdot \beta}{3} \cdot p \cdot \varepsilon \cdot V_i \quad [\text{J}] \quad (21)$$

respectively, the expression of the necessary power for pressing the material:

$$P_{pres} = \frac{F_{pres} \cdot v_{pres}}{1000} = \frac{F_{pres} \cdot \Delta l}{1000 \cdot \Delta t} = \frac{F_{pres} \cdot \Delta l}{1000 \cdot \Delta t} = \frac{L_{pres}}{1000 \cdot \Delta t} \quad [\text{kW}] \quad (22)$$

where: F_{pres} – represents the pressing force [N]; v_{pres} – the pressing speed, [m/s]; Δt – the time interval when the reducing of the material volume is performed from the initial value V_i to the final value V_f , [s]. The value of this time interval can be calculated depending on the rotative speed [rpm] of the press auger, respectively:

$$\Delta t = \frac{60}{n} \quad (23)$$

Taking into account equations (21), (22) and (23), the expression of the necessary power for pressing the material is obtained:

$$P_{pres} = \frac{L_{pres} \cdot n}{1000 \cdot 60} = \frac{(1 + 2 \cdot \beta) \cdot p \cdot \varepsilon \cdot V_i \cdot n}{3 \cdot 1000 \cdot 60} \quad [\text{kW}] \quad (24)$$

In reality, for presses in food industry, the value of the pressure, p , is not kept constant along the auger, having a variation which can be as that seen in figure 9.

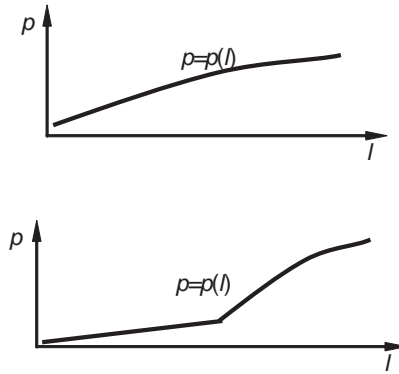

Figure 9. Pressure variation along the pressing chamber

- Power necessary to overcome the frictions between the auger spire and material

To calculate the necessary power for overcoming the frictions between the auger spire and the material, first it must be calculated the friction torque (moment), which occurs on the spire surface when it comes into contact with the material. For the calculus of this friction torque (moment) it is first taken into consideration an elementary ring, dr , situated on the auger spire on the radius r (Figure 10) and for the auger length suitable to a pitch, s it is determined the normal force exerted on the elementary ring:

$$dN = p \cdot dS = p \cdot 2 \cdot \pi \cdot r \cdot dr \tag{25}$$

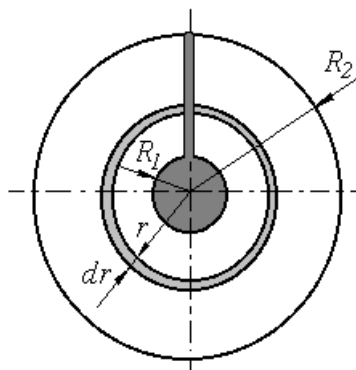

Figure 10. Elementary ring on the auger spire

The value of *the friction force* which occurs on the surface of the elementary ring is calculated by the following equation:

$$dF_f = \mu \cdot dN = \mu \cdot p \cdot 2 \cdot \pi \cdot r \cdot dr \quad (26)$$

The expression of the friction torque (moment) at the surface of the elementary ring is:

$$dM_f = r \cdot dF_f = \mu \cdot p \cdot 2 \cdot \pi \cdot r^2 \cdot dr \quad (27)$$

which, by integration, for the whole active cross surface of the auger spire, suitable to a length equal to a pitch, s , leads to the equation:

$$M_f = \int_{R_1}^{R_2} \mu \cdot p \cdot 2 \cdot \pi \cdot r^2 \cdot dr = 2 \cdot \mu \cdot p \cdot \pi \cdot \int_{R_1}^{R_2} r^2 \cdot dr = 2 \cdot \pi \cdot \mu \cdot p \cdot \frac{r^3}{3} \Big|_{R_1}^{R_2} \quad (28)$$

respectively:

$$M_f = 2 \cdot \pi \cdot \mu \cdot p \cdot \frac{R_2^3 - R_1^3}{3} \quad [\text{Nm}] \quad (29)$$

It results the expression of the necessary power for overcoming the friction between the auger spire and the material:

$$P_{fr} = \frac{M_f \cdot n}{9550} = \frac{2 \cdot \pi \cdot \mu \cdot p \cdot (R_2^3 - R_1^3) \cdot n}{3 \cdot 9550} \quad [\text{kW}] \quad (30)$$

- Power necessary for pushing the material through the exhaust space

For pushing the material through the exhaust space from the end of the pressing chamber the power consumed is given by:

$$P_{cap} = \frac{F_c \cdot v_{cap}}{1000} = \frac{F_c \cdot \frac{\Delta l_c}{\Delta t}}{1000} = \frac{F_c \cdot \Delta l_c}{1000 \cdot \Delta t} = \frac{L_c}{1000 \cdot \Delta t} = \frac{L_c \cdot n}{1000 \cdot 60} \quad [\text{kW}] \quad (31)$$

where: F_c – resistant force to material pushing through, the head of the pressing chamber, [N]; v_{cap} – the material speed through the head of the pressing chamber, [m/s]; l_c – length of exhaust canal, [m].

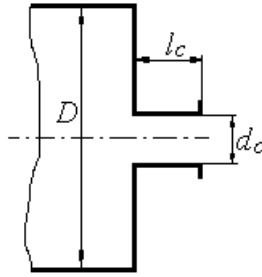

Figure 11. End of the pressing chamber

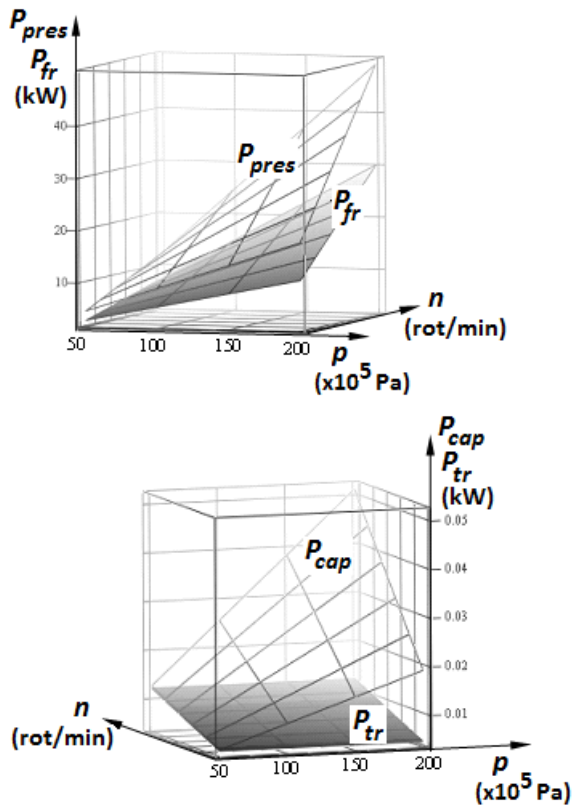

Figure 12. Power variation depending on pressure and auger rotational speed

The necessary mechanical work for pushing the material through the exhaust space (Fig. 11) for the end of the pressing chamber L_c is calculated using the following equation:

$$L_c = F_c \cdot l_c = p \cdot A_c \cdot l_c = p \cdot \frac{\pi \cdot d_c^2}{4} \cdot l_c \quad [\text{J}] \quad (32)$$

It results the expression for the calculus of power P_{cap} :

$$P_{cap} = \frac{p \cdot \pi \cdot d_c^2 \cdot l_c \cdot n}{4 \cdot 1000 \cdot 60} \quad [\text{kW}] \quad (33)$$

3. Application

Using the mathematical model developed in this study, figure 12 shows the variation of the component parts of the power necessary for operation of a press from the oil industry.

The main data taken into consideration for modelling are: the variable auger rotational speed ($n=1540 \text{ min}^{-1}$), the variable pressure inside the pressing chamber ($p=50 \cdot 10^5 \text{ Pa}$), the diameter of the pressing chamber ($D=200 \text{ mm}$), the diameter of the auger shaft ($d=100 \text{ mm}$).

4. Conclusions

The mathematical model which was created in this paper allows the high precision determination of the functional parameters and of the necessary power for operating the presses in food industry.

In figure 12 it can be observed that the necessary power for the proper pressing P_{pres} is the highest, being followed by the necessary power to overcome the frictions between the auger spire and the material subdued to pressing P_{fr} . The values for the power required to push the material through the exhaust space P_{cap} and for the material transport through the pressing chamber P_{tr} are much lower than those for the presses P_{pres} and P_{fr} , so it is possible to neglect them.

Author details

Biris Sorin-Stefan¹, Mariana Ionescu¹, Gheorghe Voicu¹, Nicoleta Ungureanu¹ and Valentin Vladut²

1 Politehnica University of Bucharest, Romania

2 INMA Bucharest, Romania

References

- [1] Adeeko, K. A., & Ajibola, O. O. (1990). Processing factors affecting yield and quality of mechanically expressed groundnut oil, *Journal of Agricultural Engineering Research*, 45, pg. , 31-43.
- [2] Ajibola, O. O., Okunade, D. A., & Owolarafe, O. K. (2002). Oil point pressure of soybean, *Journal of Food Process Engineering*, 25, pg. , 407-416.
- [3] Ajibola, O. O., Owolarafe, O. K., Fasina, O. O., & Adeeko, K. A. (1993). Expression of oil from sesame seeds, *Canadian Agricultural Engineering*, 35, pg. , 83-88.
- [4] Banu, C. (1999). Manualul inginerului din industria alimentară, vol. I și II, Editura Tehnică, București.
- [5] Bargale, P. C. (1997). Mechanical oil expression from selected oilseeds under uniaxial compression, Doctoral Thesis, University of Saskatchewan, Canada.
- [6] Biriș, S.Șt., Manea, M., Maican, E., Ungureanu, N., & Toma, L. M. (2009). a), Studies regarding the use of Finite Elements Method for the working process modelling of the oil presses, *Proceeding of the 37th International Symposium „Actual Tasks on Agricultural Engineering”*, Croația, Opatija, february, pg. 485-496., 10-13.
- [7] Biriș, S., St, , Manea, M., Paraschiv, G., Vlăduț, V., & Bungescu, S. (2009). b), Power calculus elements for oil presses, *Proceeding of the 37th International Symposium „Actual Tasks on Agricultural Engineering”*, Croația, Opatija, february, pg. 475-484., 10-13.
- [8] Bulley, N. R., Fattori, M., Meisen, A., & Moyls, L. (1984). Supercritical fluid extraction of vegetable oilseeds, *Journal of the American Oil Chemists' Society*, 61, pg. , 1362-1363.
- [9] Clifford, W. C. (1973). Theory of filtration, *Chemical Engineers' Handbook*, 5, pg. , 19-69.
- [10] Dunning, J. W. (1953). History and latest developments in expeller and screw press operation on cottonseed, *Journal of the American Oil Chemists' Society*, 30, pg., 486-492.
- [11] FAO- Food and Agriculture Organization(1989). Food Composition Table for Use in Africa. US Department of Health, Education and Welfare Press, Washington D.C.
- [12] Gurnham, F. C., & Masson, H. J. (1946). Expression of liquids from fibrous materials, *Industrial and Engineering Chemistry*, 38, pg. , 1309-1315.
- [13] Karaj, S., & Müller, J. (2009). Optimization of mechanical extraction of *Jatropha curcas* seeds, *Landtechnik* 64, pg. (3), 164-167.
- [14] Khan, L. M., & Hanna, M. A. (1983). Expression of oil from oilseeds- A review, *Journal of Agricultural Engineering Research*, 28, pg. , 495-503.
- [15] Masango, P. (2005). Cleaner production of essential oils by steam distillation, *Journal of Cleaner Production*, 13, pg. , 833-839.

- [16] Mrema, G. C. (1979). Mechanisms of mechanical oil expression from rapeseed and cashew, Doctoral Thesis, National University of Ireland, Dublin.
- [17] Ogunsina, B. S., Owolarafe, O. K., & Olatunde, G. A. (2008). Oil point pressure of cashew (*Anacardium occidentale*) kernels, *International Agrophysics*, 22, pg. , 53-59.
- [18] Sari, P. (2006). Preliminary design and construction of a prototype canola seed oil extraction machine, Doctoral Thesis, Middle East Technical University, Ankara, Turkey.
- [19] Sivalla, K., Bhole, N. C., & Mujherjee, R. K. (1991). Effects of moisture on rice bran oil expression, *Journal of Agricultural Engineering Research*, 50, pg. , 81-91.
- [20] Sukumaran, C. R., & Singh, B. (1989). Compression of a bed of rapeseeds- the oil point, *Journal of Agricultural Engineering Research*, 42, pg. , 77-84.
- [21] Terzaghi, K. (1954). *Theoretische Bodenmechanik*, Berlin: Springer.
- [22] Venter, M. J., Kuipers, N. J. M., & de Haan, A. B. (2007). Modelling and experimental evaluation of high-pressure expression of cocoa nibs, *Journal of Food Engineering*, 80, pg. , 1157-1170.
- [23] Willems, P. (2007). Gas Assisted Mechanical Expression Of Oilseeds, Doctoral Thesis, University of Twente, Netherland.
- [24] Willems, P., Kuipers, N. J. M., & De Haan, A. B. (2008). Hydraulic pressing of oilseeds: Experimental determination and modelling of yield and pressing rates, *Journal of Food Engineering*, 89, pg. , 8-16.

