

# PID Control Theory

Kambiz Arab Tehrani<sup>1</sup> and Augustin Mpanda<sup>2,3</sup>

<sup>1</sup>University of Nancy, Teaching and Research at the University of Picardie, INSSET,  
Saint-Quentin, Director of Power Electronic Society IPDRP,

<sup>2</sup>Tshwane University of Technology/FSATI

<sup>3</sup>ESIEE-Amiens

<sup>1,3</sup>France

<sup>2</sup>South Africa

## 1. Introduction

Feedback control is a control mechanism that uses information from measurements. In a feedback control system, the output is sensed. There are two main types of feedback control systems: 1) positive feedback 2) negative feedback. The positive feedback is used to increase the size of the input but in a negative feedback, the feedback is used to decrease the size of the input. The negative systems are usually stable. A PID is widely used in feedback control of industrial processes on the market in 1939 and has remained the most widely used controller in process control until today. Thus, the PID controller can be understood as a controller that takes the present, the past, and the future of the error into consideration. After digital implementation was introduced, a certain change of the structure of the control system was proposed and has been adopted in many applications. But that change does not influence the essential part of the analysis and design of PID controllers. A proportional-integral-derivative controller (PID controller) is a method of the control loop feedback. This method is composing of three controllers [1]:

1. Proportional controller (PC)
2. Integral controller (IC)
3. Derivative controller (DC)

### 1.1 Role of a Proportional Controller (PC)

The role of a proportional depends on the present error, I on the accumulation of past error and D on prediction of future error. The weighted sum of these three actions is used to adjust Proportional control is a simple and widely used method of control for many kinds of systems. In a proportional controller, steady state error tends to depend inversely upon the proportional gain (ie: if the gain is made larger the error goes down). The proportional response can be adjusted by multiplying the error by a constant  $K_p$ , called the proportional gain. The proportional term is given by:

$$P = K_p \cdot error(t) \quad (1)$$

A high proportional gain results in a large change in the output for a given change in the error. If the proportional gain is very high, the system can become unstable. In contrast, a

small gain results in a small output response to a large input error. If the proportional gain is very low, the control action may be too small when responding to system disturbances. Consequently, a proportional controller ( $K_p$ ) will have the effect of reducing the rise time and will reduce, but never eliminate, the steady-state error.

In practice the proportional band (PB) is expressed as a percentage so:

$$PB\% = \frac{100}{K_p} \quad (2)$$

Thus a PB of 10%  $\Leftrightarrow K_p=10$

### 1.2 Role of an Integral Controller (IC)

An Integral controller (IC) is proportional to both the magnitude of the error and the duration of the error. The integral in a PID controller is the sum of the instantaneous error over time and gives the accumulated offset that should have been corrected previously. Consequently, an integral control ( $K_i$ ) will have the effect of eliminating the steady-state error, but it may make the transient response worse.

The integral term is given by:

$$I = K_I \int_0^t error(t) dt \quad (3)$$

### 1.3 Role of a Derivative Controller (DC)

The derivative of the process error is calculated by determining the slope of the error over time and multiplying this rate of change by the derivative gain  $K_d$ . The derivative term slows the rate of change of the controller output. A derivative control ( $K_d$ ) will have the effect of increasing the stability of the system, reducing the overshoot, and improving the transient response. The derivative term is given by:

$$D = K_D \cdot \frac{derror(t)}{dt} \quad (4)$$

Effects of each of controllers  $K_p$ ,  $K_d$ , and  $K_i$  on a closed-loop system are summarized in the table shown below in tableau 1.

## 2. PID controller (PIDC)

A typical structure of a PID control system is shown in Fig.1. Fig.2 shows a structure of a PID control system. The error signal  $e(t)$  is used to generate the proportional, integral, and

Parameter	Rise time	Overshoot	Settling time	Steady-state error
$K_p$	Decrease	Increase	Small change	Decrease
$K_i$	Decrease	Increase	Increase	Decrease significantly
$K_d$	Minor decrease	Minor decrease	Minor decrease	No effect in theory

Table 1. A PID controller in a closed-loop system

derivative actions, with the resulting signals weighted and summed to form the control signal  $u(t)$  applied to the plant model.

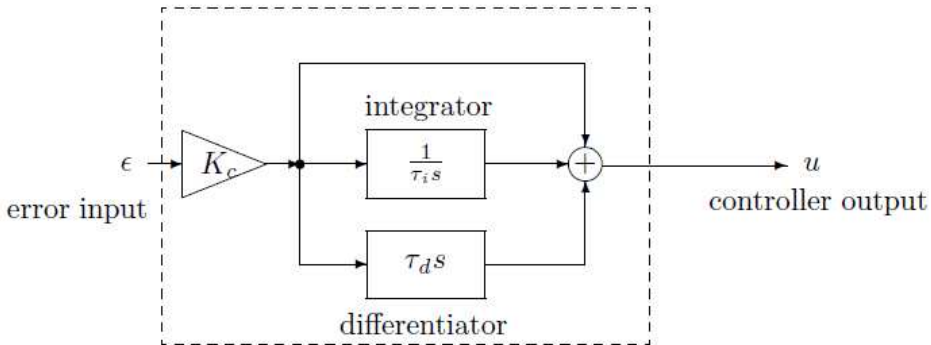

Fig. 1. A PID control system

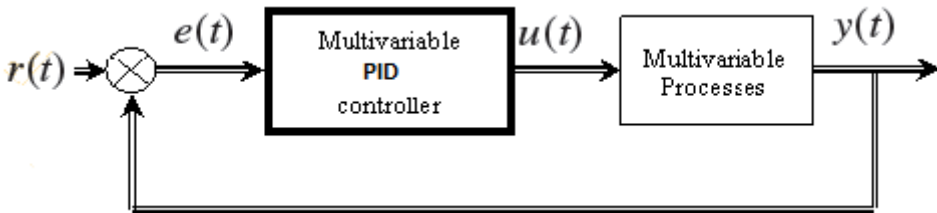

Fig. 2. A structure of a PID control system

where  $u(t)$  is the input signal to the multivariable processes, the error signal  $e(t)$  is defined as  $e(t) = r(t) - y(t)$ , and  $r(t)$  is the reference input signal.

A standard PID controller structure is also known as the “three-term” controller. This principle mode of action of the PID controller can be explained by the parallel connection of the P, I and D elements shown in Figure 3.

Block diagram of the PID controller

$$G(s) = K_p \left( 1 + \frac{1 + T_I \cdot T_D \cdot s^2}{T_I \cdot s} \right) = K_p \left( 1 + \frac{1}{T_I s} + T_D s \right) \tag{5}$$

where  $K_p$  is the proportional gain,  $T_I$  is the integral time constant,  $T_D$  is the derivative time constant,  $K_I = K_p / T_I$  is the integral gain and  $K_D = K_p T_D$  is the derivative gain. The “three-term” functionalities are highlighted below. The terms  $K_p$ ,  $T_I$  and  $T_D$  definitions are:

- The proportional term: providing an overall control action proportional to the error signal through the all pass gain factor.
- The integral term: reducing steady state errors through low frequency compensation by an integrator.
- The derivative term: improving transient response through high frequency compensation by a differentiator.

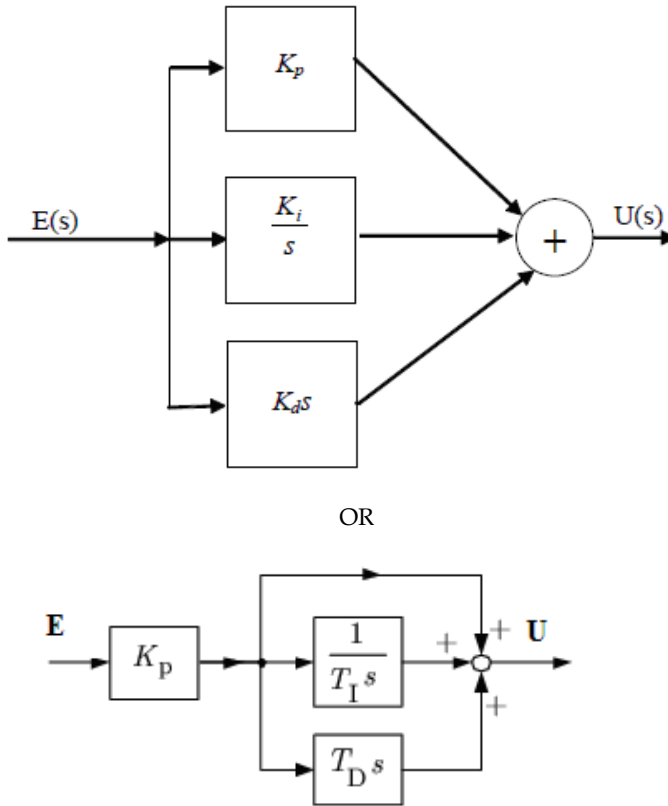

Fig. 3. Parallel Form of the PID Compensator

These three variables  $K_p$ ,  $T_i$  and  $T_D$  are usually tuned within given ranges. Therefore, they are often called the *tuning parameters* of the controller. By proper choice of these tuning parameters a controller can be adapted for a specific plant to obtain a good behaviour of the controlled system.

The time response of the controller output is

$$U(t) = K_p(e(t) + \frac{0}{T_i} \int_0^t e(t) dt + T_d \frac{de(t)}{dt}) \quad (6)$$

Using this relationship for a step input of  $e(t)$ , i.e.  $e(t) = \delta(t)$ , the step response  $r(t)$  of the PID controller can be easily determined. The result is shown in below. One has to observe that the length of the arrow  $K_p T_D$  of the D action is only a measure of the weight of the  $\delta$  impulse.

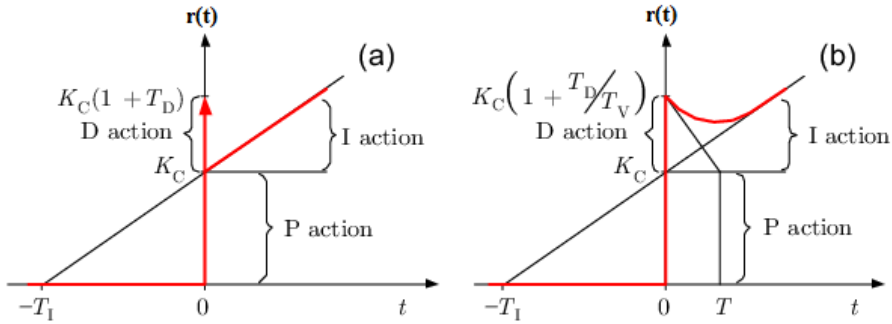

Fig. 4. a) Step response of PID ideal form b) Step response of PID real form

**2.1 The transfer function of the PID controller**

The transfer function of the PID controller is

$$G(s) = \frac{U(s)}{E(s)} \tag{7}$$

$$G(s) = K_p + \frac{K_I}{s} + K_D s = \frac{K_D s^2 + K_p s + K_I}{s} \tag{8}$$

**2.2 PID pole zero cancellation**

The PID equation can be written in this form:

$$G(s) = \frac{K_d(s^2 + \frac{K_p}{K_d}s + \frac{K_i}{K_d})}{s} \tag{9}$$

When this form is used it is easy to determine the closed loop transfer function.

$$H(s) = \frac{1}{s^2 + 2\xi\omega_0 s + \omega_0^2} \tag{10}$$

If

$$\frac{K_i}{K_d} = \omega_0^2 \tag{11}$$

$$\frac{K_p}{K_d} = 2\xi\omega_0 \tag{12}$$

Then

$$G(s)H(s) = \frac{K_d}{s} \tag{13}$$

This can be very useful to remove unstable poles.

There are several prescriptive rules used in PID tuning. The most effective methods generally involve the development of some form of process model, and then choosing P, I, and D based on the dynamic model parameters.

### 2.3 Tuning methods

We present here four tuning methods for a PID controller [2,3].

Method	Advantages	Disadvantages
Manual	Online method No math expression	Requires experienced personnel
Ziegler-Nichols	Online method Proven method	Some trial and error, process upset and very aggressive tuning
Cohen-Coon	Good process models	Offline method Some math Good only for first order processes
Software tools	Online or offline method, consistent tuning, Support Non-Steady State tuning	Some cost and training involved
Algorithmic	Online or offline method, Consistent tuning, Support Non-Steady State tuning, Very precise	Very slow

#### 2.3.1 The Ziegler–Nichols tuning method

The Ziegler–Nichols tuning method is a heuristic method of tuning a PID controller. It was proposed by John G. Ziegler and Nichols in the 1940's. It is performed by setting I (integral) and D (derivative) gains to zero. The P (proportional) gain,  $K_p$  is then increased (from zero) until it reaches the ultimate gain  $K_u$ , at which the output of the control loop oscillates with a constant amplitude.  $K_u$  and the oscillation period  $T_u$  are used to set the P, I, and D gains depending on the type of controller used [3,4]:

Ziegler–Nichols method			
Control Type	$K_p$	$K_i$	$K_d$
<b>P</b>	$K_u / 2$	-	-
<b>PI</b>	$K_u / 2.2$	$1.2K_p / T_u$	-
<b>PID</b>	$0.60K_u$	$2K_p / T_u$	$K_p T_u / 8$
<b>Some overshoot</b>	$0.33K_u$	$2K_p / T_u$	$K_p T_u / 3$
<b>No overshoot</b>	$0.2K_u$	$2K_p / T_u$	$K_p T_u / 3$

We can realise a PID controller by two methods:

First, an analog PID controller

Second, a digital PID controller

1. Circuit diagram below (figure.5) shows an analog PID controller. In this figure, we present an analog PID controller with three simple op amp amplifier, integrator and differentiator circuits.

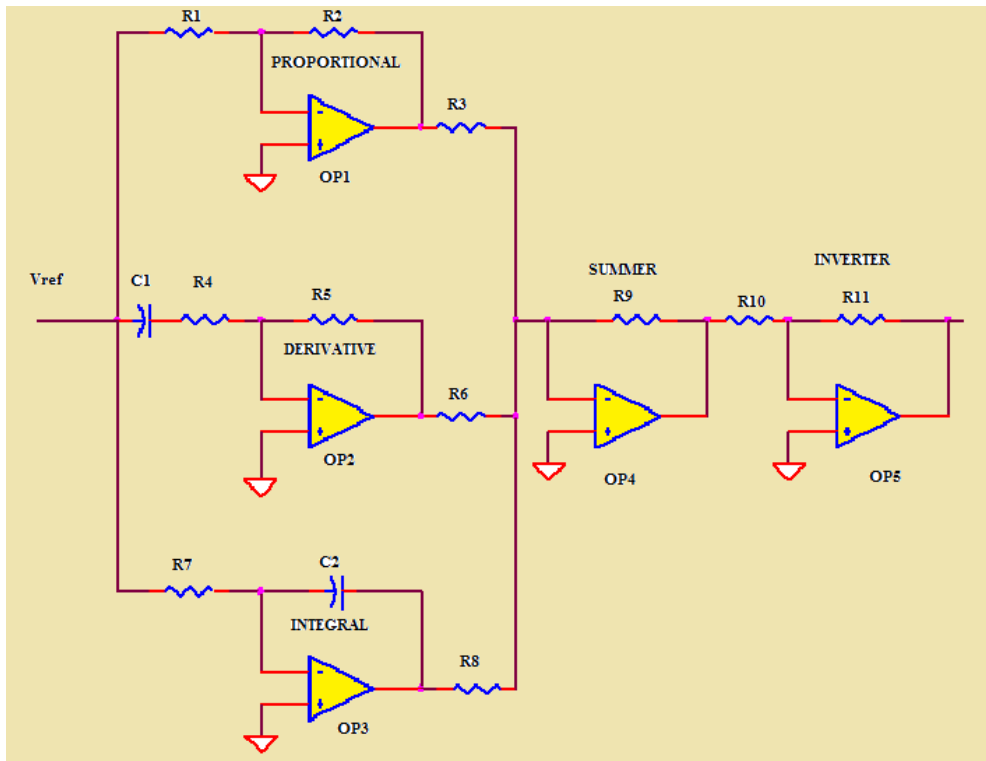

Fig. 5. Electronic circuit implementation of an analog PID controller

TERM	DEFINITION	Op Amp Circuit Function
<b>P</b>	<b>Proportional/ Amplifier</b>	$V_o=(R2/R1).V_{ref}$
<b>D</b>	<b>Differentiator</b>	$V_o=R5.C1.dV_{ref}/dt$
<b>I</b>	<b>Integrator</b>	$V_o=1/(R7.C2). \int V_{ref} dt$

Finally, we need to add the three PID terms together. Again the summing amplifier OP4 serves us well. Because the error amp, PID and summing circuits are inverting types, we need to add a final op amp inverter OP5 to make the final output positive.

- Today, digital controllers are being used in many large and small-scale control systems, replacing the analog controllers. It is now a common practice to implement PID controllers in its digital version, which means that they operate in discrete time domain and deal with analog signals quantized in a limited number of levels. Moreover, in such controller we do not need much space and they are not expensive. A digital version of the PID controller is shown in figure 6 [5,6].

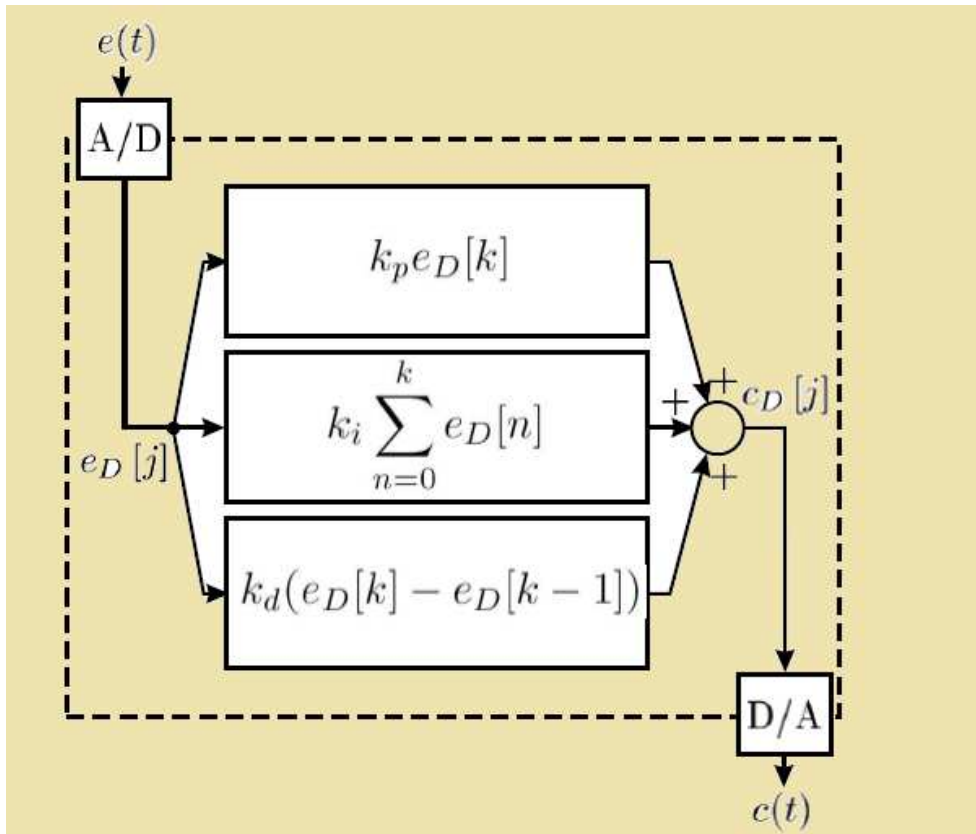

Fig. 6. Digital PID Controller

In its digital version, the integral becomes a sum and the differential a difference. The continuous time signal  $e(t)$  is sampled in fixed time intervals equals a determined sample period, here called  $T_c$  (in figure 6  $T_c = 1$ ). An A/D (analog to digital) converter interfaces the input and a D/A (digital to analog) converter interfaces the output. This sampled and digitalized input, called  $e_D[j]$ , exists only in time instants  $t = kT_c$  for all  $k \geq 0 \in Z$ . A lower bound for the sample period is the computing time of a whole cycle of the digital PID (which includes the A/D and D/A conversion).



While PID controllers are applicable to many control problems, and often perform satisfactorily without any improvements or even tuning, they can perform poorly in some applications, and do not in general provide optimal control.

### 3. Fractional systems

Fractional order systems are characterized by fractional-order differential equations. Fractional calculus considers any real number for derivatives and integrals. The FOPID controller is the expansion of the conventional integer-order PID controller based on fractional calculus [7,8].

#### 3.1 Fractional-order PID (FOPID) controller

The PIDs are linear and in particular symmetric and they have difficulties in the presence of non-linearities. We can solve this problem by using a fractional-order PID (FOPID) controller. A FOPID controller is presented below [7-9]:

$$G(s) = K_p + \frac{K_I}{s^\alpha} + K_D s^\beta = \frac{K_p s^\alpha + K_I + K_D s^\alpha s^\beta}{s^\alpha} \tag{14}$$

Figure.7 describes the possibilities a FOPID for the different controllers.

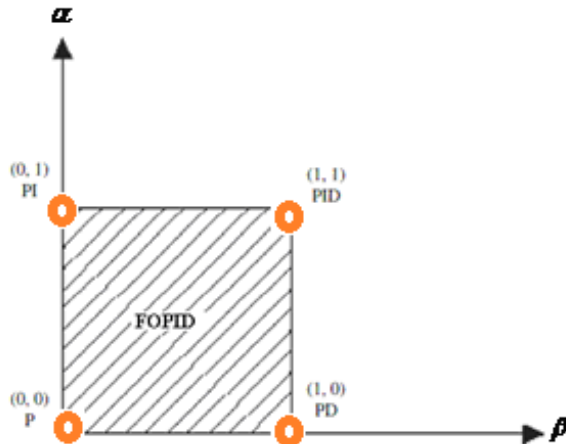

Fig. 7. Generalization of the FOPID controller: from point to plane.

There are several methods to calculate the fractional order derivative and integrator of a fractional order PID controller. For this purpose we present a real order calculus according to the Riemann-Liouville definition.

**3.2 Fractional calculus**

Fractional calculus is a branch of mathematics dealing with real number powers of differential or integral operators. It generalizes the common concepts of derivative and integral. Among all the different definitions, the definition which has been proposed by Riemann and Liouville is the most usual one [9,10]. The definition is as follows:

$${}_c D_x^{-n} f(x) = \int_c^x \frac{(x-t)^{n-1}}{(n-1)!} f(t) dt, \quad n \in \mathfrak{R} \tag{15}$$

The general definition of D is given by (2):

$${}_c D_x^v f(x) = \begin{cases} \int_c^x \frac{(x-t)^{-v-1}}{\Gamma(-v)} f(t) dt, & \text{if } v < 0 \\ f(x) & \text{if } v = 0 \\ D^n [{}_c D_x^{v-n} f(x)] & \text{if } v > 0 \end{cases} \tag{16}$$

$$n = \min \{K \in \mathfrak{R}, K > v\}$$

Where  $\Gamma(\cdot)$  is the well-known Euler's gamma function.

Function  $F(s) = s^v$  (17)

Function (17) is not only the simplest fractional order transfer function that may appear but is also very important for applications, as shall be seen subsequently. For that reason, we analyse its time and frequency responses.

Time responses of (17)

The derivatives of the exponential function are given by

$${}_0 D_t^v e^{at} = E_t(-v, a), t > 0 \tag{18}$$

For negative orders, from definition (16) we have:

$${}_0 D_t^{-v} e^{at} = \frac{1}{\Gamma(v)} \int_0^t (t-\xi)^{v-1} e^{a\xi} d\xi, v \in \mathfrak{R}^+ \tag{19}$$

By means of the substitution  $x = t - \xi$ , in the first place, and of the substitution  $ax = y$ , in the second place, we obtain

$$\begin{aligned} {}_0 D_t^{-v} e^{at} &= -\frac{1}{\Gamma(v)} \int_t^0 x^{v-1} e^{a(t-x)} dx = \frac{e^{at}}{\Gamma(v)} \int_0^t x^{v-1} e^{-ax} dx = \\ &= \frac{e^{at}}{\Gamma(v)} \int_0^{at} \left(\frac{y}{a}\right)^{v-1} e^{-y} \frac{dy}{a} = \frac{e^{at}}{\Gamma(v)a^v} \int_0^{at} y^{v-1} e^{-y} dy = E_t(v, a) \end{aligned} \tag{20}$$

For positive orders, the same definition gives

$${}_0D_t^\nu e^{at} = D^n {}_0D_t^{\nu-n} e^{at} = \frac{d^n}{dt^n} E_t(n-\nu, a) = E_t(-\nu, a), \nu \in \mathfrak{R}^+ \wedge n = \min\{k \in \mathbb{N} : k > \nu\}$$

If  $\nu = 0$ , we have:

$$E_t(0, a) = \sum_{k=0}^{+\infty} \frac{(at)^k}{\Gamma(k+1)} \tag{21}$$

which is the series development of  $e^{at}$ .

Finally, the Laplace transform of  $E_t$  is:

$$\ell[E_t(\nu, a)] = \frac{1}{s^\nu (s-a)} \tag{22}$$

The Convolution theorem:

$$\ell\left[\int_0^t f(t-\tau)g(\tau)d\tau\right] = \ell[f(t)]\ell[g(t)] \tag{23}$$

For negative orders, applying the convolution theorem (23) and (19) we obtain

$$\ell[E_t(\nu, a)] = \frac{1}{\Gamma(\nu)} \ell[t^{\nu-1}] \ell[e^{at}] = \frac{1}{s^\nu (s-a)} \tag{24}$$

For positive orders, applying the Laplace transform and we have:

$$\ell[E_t(-\nu, a)] = \ell\left[\frac{d^n}{dt^n} E_t(n-\nu, a)\right] = \frac{s^n}{s^{n-\nu}(s-a)} = \frac{1}{s^{-\nu}(s-a)} \tag{25}$$

And when  $\nu = 0$ , we find:

$$\ell[E_t(0, a)] = \ell[e^{at}] = \frac{1}{s-a} \tag{26}$$

### 3.3 Approximation of fractional order

Approximation of Fractional Order Derivative and Integral There are many different ways of finding such approximations but unfortunately it is not possible to say that one of them is the best, because even though some are better than others in regard to certain characteristics, the relative merits of each approximation depend on the differentiation order, on whether one is more interested in an accurate frequency behaviour or in accurate time responses, on how large admissible transfer functions may be, and other factors such like these. For that reason this section shall present several alternatives and conclude with a comparison of them.

Approximations are available both in the s-domain and in the z-domain. The former shall henceforth be called continuous approximations or approximations in the frequency domain; the latter, discrete approximations, or approximations in the time domain.

There are 32 approximation methods for fractional order derivative and integral, we present here Crone approximation method [10, 11].

### 3.3.1 Crone approximation method

The Crone methodology provides a continuous approximation, based on a recursive distribution of zeros and poles. Such a distribution, alternating zeros and poles at well-chosen intervals, allows building a transfer function with a gain nearly linear on the logarithm of the frequency and a phase nearly constant being possible for the values of the slope of the gain and of the phase for any value of  $\nu$  [12-14].

The functions we are dealing with in this section provide integer-order frequency-domain approximation of transfer functions involving fractional powers of s.

For the frequency-domain transfer function  $C(s)$  which is given by:

$$C(s) = Ks^\nu \quad \nu \in \Re \quad (27)$$

One of the well-known continuous approximation approaches is called Crone. Crone is a French acronym which means 'robust fractional order control'. This approximation implements a recursive distribution of N zeros and N poles leading to a transfer function as (28).

$$C(s) = K' \prod_{n=1}^N \frac{1 + \frac{s}{\omega_{zn}}}{1 + \frac{s}{\omega_{pn}}} \quad (28)$$

Where  $K'$  is an adjusted gain so that both (26) and (27) have unit gain at 1 rad/s. Zeros and poles have to be found over a frequency domain  $[\omega_l, \omega_h]$  where the approximation is valid, they are given for a positive  $\nu$ , by (29), (30) and (31).

$$\omega_{z1} = \omega_l \sqrt{\eta} \quad (29)$$

$$\omega_{pn} = \omega_{z,n-1} \alpha \quad n = 1 \dots N \quad (30)$$

$$\omega_{zn} = \omega_{p,n-1} \eta \quad n = 2 \dots N \quad (31)$$

Where  $\alpha$  and  $\eta$  can be calculated thanks to (32) and (33).

$$\alpha = \left( \frac{\omega_h}{\omega_l} \right)^{\frac{\nu}{N}} \quad (32)$$

$$\eta = \left( \frac{\omega_h}{\omega_l} \right)^{\frac{1-\nu}{N}} \quad (33)$$

For negative values of  $\nu$ , the role of the zeros and the poles is swapped. The number of poles and zeros is selected at first and the desired performance of this approximation depends on the order  $N$ . Simple approximation can be provided with lower order  $N$ , but it can cause ripples in both gain and phase characteristics. When  $|\nu| > 1$ , the approximation is not satisfactory. The fractional order  $\nu$  usually is separated as (34) and only the first term  $s^\rho$  needs to be approximated.

$$s^\nu = s^\rho s^n, \quad \nu = n + \rho, \quad n \in \mathbb{R}, \quad \rho \in [0, 1] \tag{34}$$

### 3.4 Bode and Nichols plots of $s^\nu$ for real orders

The frequency response of  $s^\nu$  is:

$$\begin{aligned} F(j\omega) &= (j\omega)^\nu \\ |F(j\omega)| &= |j^\nu \omega^\nu| = |\omega^\nu| = \omega^\nu \\ \arg[F(j\omega)] &= \arg(j^\nu \omega^\nu) = \arg(j^\nu) \end{aligned} \tag{35}$$

Now there are several complex numbers  $z$  with different arguments such that  $z = j^\nu$ ; by choosing the one with a lower argument in interval  $[0; 2\pi[$ , we will obtain:

$$\arg[F(j\omega)] = \nu\pi / 2 \tag{36}$$

The gain in decibel shall be

$$|F(j\omega)| = 20 \log \omega^\nu = 20\nu \log \omega \quad (\text{dB}) \tag{37}$$

Thus the Bode and Nichols plots of  $F(s) = s^\nu$  are those shown in Figure 8 and Figure 9:

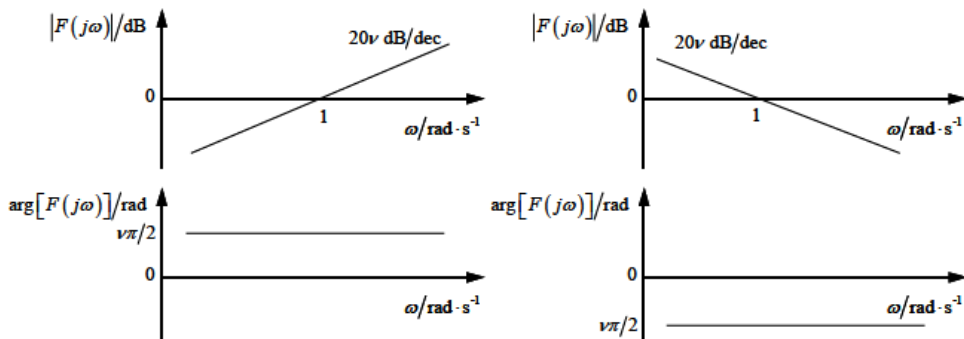

Fig. 8. Bode diagrams

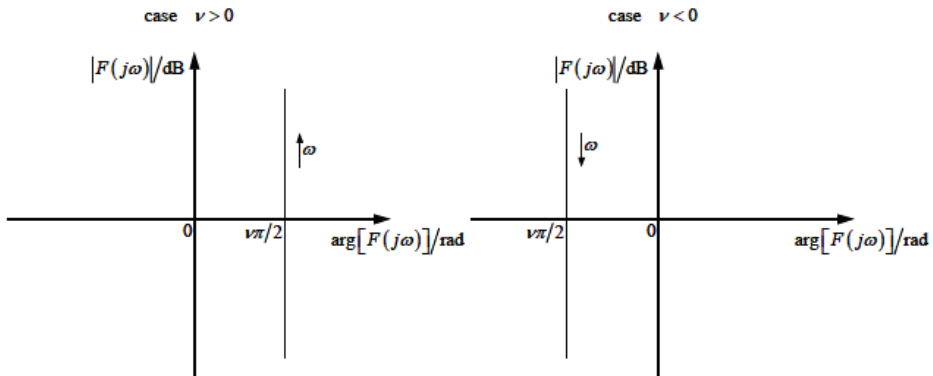

Fig. 9. Nichols diagrams

### 4. Conclusions

Manny industrial processes are nonlinear and thus complicate to describe mathematically. However, it is known that a good many nonlinear processes can satisfactory controlled using PID controllers providing that controller parameters are tuned well. PID controller and its different types such as P, PI and PD controllers are today basic building blocks in control of various processes. In spite their simplicity; they can be used to solve even a very complex control problems, especially when combined with different functional blocks, filters (compensators or correction blocks), selectors etc. One of the ways to improve the traditional PID controllers is to use fractional order controllers with non integer derivation and integration parts. However, the difficulties of designing Fractional Order PID (FOPID) is relatively higher because these controllers include derivative order and integer order in comparison with traditional PID controllers. As for a linear system, if the dynamic characteristics are basically the same using either integer-order PID controller or FOPID controller, the result of using FOPID controller may provide a better robustness. We get the optimal control with a FOPID than a conventional PID controller.

### 5. Annex

Controller type	$K_p$	$K_i$	$K_d$	$C(s)$
P (Proportional)	$\neq 0$	zero	zero	$K_p$
I (Integral)	zero	$\neq 0$	zero	$\frac{K_i}{s}$
PI (Proportional plus Integral)	$\neq 0$	$\neq 0$	zero	$\frac{K_p s + K_i}{s} = \frac{K_p \left( s + \frac{K_i}{K_p} \right)}{s}$
PD (Proportional plus Derivative)	$\neq 0$	zero	$\neq 0$	$K_d s + K_p = K_d \left( s + \frac{K_p}{K_d} \right)$
PID (Proportional + Integral + Derivative)	$\neq 0$	$\neq 0$	$\neq 0$	$\frac{K_d s^2 + K_p s + K_i}{s} = \frac{K_d \left( s^2 + \frac{K_p}{K_d} s + \frac{K_i}{K_d} \right)}{s}$

V	Approximated transfer function for an FOPID
0.1	$\frac{1584.8932(s + 0.1668)(s + 27.83)}{(s + 0.1)(s + 16.68)(s + 2783)}$
0.2	$\frac{79.4328(s + 0.05623)(s + 1)(s + 17.78)}{(s + 0.03162)(s + 0.5623)(s + 10)(s + 177.8)}$
0.3	$\frac{39.8107(s + 0.0416)(s + 0.3728)(s + 3.34)(s + 29.94)}{(s + 0.02154)(s + 0.1931)(s + 1.73)(s + 15.51)(s + 138.9)}$
0.4	$\frac{35.4813(s + 0.03831)(s + 0.261)(s + 1.778)(s + 12.12)(s + 82.54)}{(s + 0.01778)(s + 0.1212)(s + 0.8254)(s + 5.623)(s + 38.31)(s + 261)}$
0.5	$\frac{15.8489(s + 0.03981)(s + 0.2512)(s + 1.585)(s + 10)(s + 63.1)}{(s + 0.01585)(s + 0.1)(s + 0.631)(s + 3.981)(s + 3.981)(s + 25.12)(s + 158.5)}$
0.6	$\frac{10.7978(s + 0.04642)(s + 0.3162)(s + 2.154)(s + 14.68)(s + 100)}{(s + 0.01468)(s + 0.1)(s + 0.631)(s + 4.642)(s + 31.62)(s + 215.4)}$
0.7	$\frac{9.3633(s + 0.06449)(s + 0.578)(s + 5.179)(s + 46.42)(s + 416)}{(s + 0.01389)(s + 0.1245)(s + 1.116)(s + 10)(s + 89.62)(s + 803.1)}$
0.8	$\frac{5.3088(s + 0.1334)(s + 2.371)(s + 42.17)(s + 749.9)}{(s + 0.01334)(s + 0.2371)(s + 4.217)(s + 74.99)(s + 1334)}$
0.9	$\frac{2.2675(s + 1.292)(s + 215.4)}{(s + 0.01292)(s + 2.154)(s + 359.4)}$

Table 2. Approximation of  $1/s^v$  for different  $v$  values

## 6. References

- [1] K. Astrom, K. and T.Hagglund, "PID Controllers: Theory, Design, and Tuning", Instrument Society of America, ISBN 1-55617-516-7, 1995
- [2] Barbosa, Ramiro S.; Machado, J. A. Tenreiro; FERREIRA, Isabel M, A fractional calculus perspective of PID tuning. In Proceedings of ASME 2003 design engineering technical conferences and Computers and information in engineering conference. Chicago: ASME, 2003.
- [3] Barbosa, Ramiro S.; Machado, J. A. Tenreiro; Ferreira, Isabel M, Tuning of PID controllers based on Bode's ideal transfer function. Nonlinear dynamics. 38 (2004a) 305-321.
- [4] D. Maiti, A. Acharya M. Chakraborty, A. Konar, R. Janarthanan, "Tuning PID and Fractional PID Controllers using the Integral Time Absolute Error Criterion" 4th International Conference on Information and Automation for Sustainability, 2008 , pp. 457-462
- [5] Z. Yongpeng , Sh. Leang-San , M. A.Cajetan , and A. Warsame, " Digital PID controller design for delayed multivariable systems", Asian Journal of Control, Vol. 6, No. 4, Dec 2004, pp. 483-495.
- [6] Pierre, D.A. and J.W. Pierre, "Digital Controller Design-Alternative Emulation Approaches," ISA Trans.Vol. 34, No. 3, (1995), pp. 219-228.
- [7] D. Xue, C. N. Zhao and Y. Q. Chen, "Fractional order PID control of a DC-motor with an elastic shaft: a case study," Proceedings of American Control Conference, pp. 3182-3187, June 2006.

- [8] L. Debnath, "A brief historical introduction to fractional calculus," *Int. J. Math. Educ. Sci. Technol.*, vol. 35, no. 4, pp. 487-501, 2004.
- [9] Y. Q. Chen, D. Xue and H. Dou, "Fractional Calculus and Biomimetic Control," *Proc. of the First IEEE Int. Conf. on Robotics and Biomimetics (RoBio04)*, pp. robio2004-347, August 2004.
- [10] D. Valrio, "Fractional Robust System Control," PhD thesis, Instituto Superior Tcnico, Universidade Tcnica de Lisboa, 2005.
- [11] TSENG, Chien-Cheng, "Design of fractional order digital FIR differentiators". *IEEE signal processing letters*. 8:3 (2001) 77-79.
- [12] Concepcion Alicia Monje Micharet. "Design Methods of Fractional Order Controllers for Industrial Applications". Ph.D. thesis, University of Extremadura, Spain, 2006.
- [13] Youxin Luo, Jianying Li, "The Controlling Parameters Tuning and its Application of Fractional Order PID Bacterial Foraging-based Oriented by Particle Swarm Optimization" *IEEE International Conference on Intelligent Computing and Intelligent Systems*, 2009, pp. 4-7.
- [14] Tehrani, K.A. Amirahmadi, A. Rafiei, S.M.R. Griva, G. Barrandon, L. Hamzaoui, M. Rasoanarivo, I. Sargos, F.M., "Design of fractional order PID controller for boost converter based on Multi-Objective optimization", *Power Electronics and Motion Control Conference (EPE/PEMC)*, 2010 14th International, Ohrid 6-8 Sept. 2010, pp: 179-185.



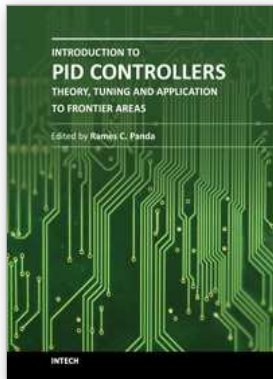

## **Introduction to PID Controllers - Theory, Tuning and Application to Frontier Areas**

Edited by Prof. Ramesh C. Panda

ISBN 978-953-307-927-1

Hard cover, 258 pages

**Publisher** InTech

**Published online** 29, February, 2012

**Published in print edition** February, 2012

This book discusses the theory, application, and practice of PID control technology. It is designed for engineers, researchers, students of process control, and industry professionals. It will also be of interest for those seeking an overview of the subject of green automation who need to procure single loop and multi-loop PID controllers and who aim for an exceptional, stable, and robust closed-loop performance through process automation. Process modeling, controller design, and analyses using conventional and heuristic schemes are explained through different applications here. The readers should have primary knowledge of transfer functions, poles, zeros, regulation concepts, and background. The following sections are covered: The Theory of PID Controllers and their Design Methods, Tuning Criteria, Multivariable Systems: Automatic Tuning and Adaptation, Intelligent PID Control, Discrete, Intelligent PID Controller, Fractional Order PID Controllers, Extended Applications of PID, and Practical Applications. A wide variety of researchers and engineers seeking methods of designing and analyzing controllers will create a heavy demand for this book: interdisciplinary researchers, real time process developers, control engineers, instrument technicians, and many more entities that are recognizing the value of shifting to PID controller procurement.

### **How to reference**

In order to correctly reference this scholarly work, feel free to copy and paste the following:

Kambiz Arab Tehrani and Augustin Mpanda (2012). PID Control Theory, Introduction to PID Controllers - Theory, Tuning and Application to Frontier Areas, Prof. Ramesh C. Panda (Ed.), ISBN: 978-953-307-927-1, InTech, Available from: <http://www.intechopen.com/books/introduction-to-pid-controllers-theory-tuning-and-application-to-frontier-areas/theory-of-pid-and-fractional-order-pid-fopid-controllers>

**INTECH**  
open science | open minds

### **InTech Europe**

University Campus STeP Ri  
Slavka Krautzeka 83/A  
51000 Rijeka, Croatia  
Phone: +385 (51) 770 447  
Fax: +385 (51) 686 166  
[www.intechopen.com](http://www.intechopen.com)

### **InTech China**

Unit 405, Office Block, Hotel Equatorial Shanghai  
No.65, Yan An Road (West), Shanghai, 200040, China  
中国上海市延安西路65号上海国际贵都大饭店办公楼405单元  
Phone: +86-21-62489820  
Fax: +86-21-62489821

© 2012 The Author(s). Licensee IntechOpen. This is an open access article distributed under the terms of the [Creative Commons Attribution 3.0 License](#), which permits unrestricted use, distribution, and reproduction in any medium, provided the original work is properly cited.