

# Thalassemia Syndrome

Tangvarasittichai Surapon  
*Chronic Diseases Research Unit, Department of Medical Technology,  
Naresuan University, Phitsanulok  
Thailand*

## 1. Introduction

Thalassemia is an inherited disorder of autosomal recessive gene disorder caused by impaired synthesis of one or more globin chains. The impairment alters production of hemoglobin (Hb) (Ridolfi et al., 2002). Thalassemia causes varying degrees of anemia, which can range from significant to life threatening. People of Mediterranean, Middle Eastern, African, and Southeast Asian descent are at higher risk of carrying the genes for thalassemia (Weatherall, 1997). These hereditary anemias are caused by mutations that decrease hemoglobin synthesis and red cell survival. These hereditary anemia caused by decreased or absent production of one type of globin chain either  $\alpha$  or  $\beta$  globin chain. These hematologic disorders range from asymptomatic to severe anemia that can cause significant morbidity and mortality. It was first recognized clinically in 1925 by Dr. Thomas Cooley, who described a syndrome of anemia with microcytic erythrocytes. Then it was called Cooley's anemia. Later Wipple and Bradford renamed this disease as "Thalassemia". Because it was found in the region of the Mediterranean Sea (thalasa is an old Greek word for sea) (Cooley, 1946). Thalassemias can cause significant problems because these are inherited disorders, newborn screening and prenatal diagnosis are important in management of patients. This topic will review the clinical features of thalassemia while focusing on pathophysiology, clinical features, complication, management, screening and diagnosis. Formerly the distribution of thalassemia had been mainly limited to the areas from the Mediterranean basin through the Middle East and Indian subcontinent up to Southeast Asia so called "thalassemia belt" (Chernoff, 1959). However, recent migrations of people have spread thalassemia genes throughout the world.

## 2. Pathophysiology

Hemoglobin (Hb) is the molecule that carries and transports oxygen all through the body. Normal human hemoglobin is a tetramer formed by two pairs of globin chains attached to heme. The hemoglobin type is determined by the combination of tetra-globin chains ( $\alpha$ ,  $\beta$ ,  $\delta$ , and  $\gamma$  chains). Each globin chain is structurally different and thus has different oxygen affinity, electrical charge, and electrophoretic mobility. Normal adult hemoglobins are expressed as A<sub>2</sub>, A and F (fetal). Ninety-five to ninety-eight percent of adult hemoglobin is A the major hemoglobin, which consists of two  $\alpha$ - and two  $\beta$ -chains ( $\alpha_2$ ,  $\beta_2$ ). Hemoglobin A<sub>2</sub> ( $\alpha_2$ ,  $\delta_2$ ), the remainder of hemoglobin in adults is a minor component (less than 3.3%), and 1% or less of F ( $\alpha_2$ ,  $\gamma_2$ ) (Nathan & Oski, 1993.), the gamma hemoglobin (Hb-F) is the

predominant hemoglobin found only during fetal development. The equal production of  $\alpha$  and non- $\alpha$  ( $\beta$ ,  $\delta$ ,  $\gamma$ ) globin chains is necessary for normal red blood cell (RBC) function. The failure in hemoglobin synthesis is a main cause of microcytosis and anemia in many population groups around the world. Hb variants are characterized by the gene mutation of the globin chains form hemoglobin (i.e., the replacement of different amino acids at a certain position). Thalassemia occurs when there is decreased or absent production of one of the types of globin chains (most commonly either  $\alpha$  or  $\beta$ ), that cause insufficient amount of normal structure globin chains. This results in an imbalance between  $\alpha$ - and  $\beta$ -chains and causes the clinical features of thalassemia (Nathan & Gunn, 1966), it can be separated into two major types such as  $\alpha$ -thalassemia and  $\beta$ - thalassemia.

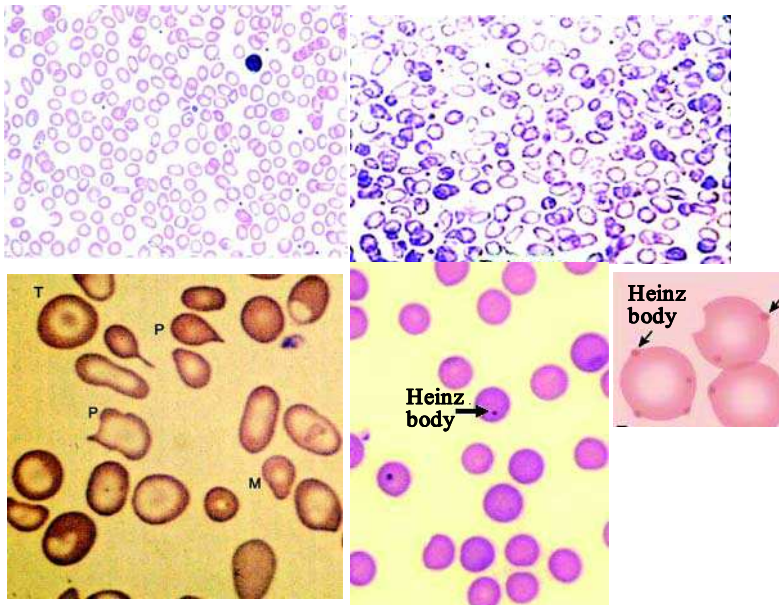

Fig. 1. Red blood cell morphology is altered in patients with all forms of thalassemia. Hypochromic microcytes and target cells are the main features in asymptomatic individuals. Patients with more severe forms of thalassemia have the anisocytosis and poikilocytosis, hypochromic microcytic, target cells, ovalocytes, occasional fragmented red blood cells

The absence or decreased of normal production of  $\alpha$ -globin chains results in a relative excess of  $\gamma$ -globin chains in the fetus and newborn, and  $\beta$ -globin chains in children and adults. When globin chains are not produced in equal amounts, any excess chains accumulate and precipitate damaging the RBC and accelerating its destruction. The absence of normal production of  $\alpha$ -chains results in a relative excess of  $\gamma$ -globin chains in the fetus and newborn, and  $\beta$ -globin chains in children and adults. Further, the  $\beta$ -globin chains are capable of forming soluble tetramers ( $\beta_4$ , or Hb-H); yet this form of hemoglobin is unstable and tends to precipitate within the cell forming insoluble inclusions (Heinz bodies) that damage the red cell membrane.  $\alpha$ -Thalassemia is generally less severe because the excess unpaired  $\beta$ -chains that accumulate are less damaging to RBCs than the unpaired  $\alpha$  chains. Furthermore, diminished hemoglobinization of individual red blood cells results in damage

to erythrocyte precursors and ineffective erythropoiesis in the bone marrow, as well as hypochromia and microcytosis of circulating red blood cells. (Fig 1)

In  $\beta$ -thalassemia, reduced amount ( $\beta^+$ ) or absence ( $\beta^0$ ) of  $\beta$ -globin chains excess  $\alpha$ -chains accumulate in the RBC and precipitate because they are highly insoluble. These precipitated globin chains occur in both erythroid precursors in the bone marrow and circulating RBCs. The destruction of precursor RBCs results in ineffective erythropoiesis, increased erythropoietin, and proliferation of the bone marrow. This expanded bone marrow (up 25 to 30 times normal) can result in the characteristic bony abnormalities of  $\beta$ -thalassemia if the process is not prevented by transfusion therapy. Prolonged and severe anemia and increased erythropoietic drive also result in hepatosplenomegaly and extramedullary erythropoiesis, leading to their premature death and hence to ineffective erythropoiesis. The degree of globin chain reduction is determined by the nature of the mutation at the  $\beta$ -globin gene located on chromosome 11. Peripheral hemolysis contributing to anemia is more prominent in thalassemia major than in thalassemia intermedia, and occurs when insoluble  $\alpha$ -globin chains induce membrane damage to the peripheral erythrocytes.

Genes that regulate both synthesis and structure of different globins are organized into 2 separate clusters. The  $\alpha$ -globin genes are encoded on chromosome 16 and the  $\gamma$ ,  $\delta$ , and  $\beta$ -globin genes are encoded on chromosome 11 as demonstrated in Fig 2. Each individual normally carries a linked pair of  $\alpha$ -globin genes, 2 from the paternal chromosome, and 2 from the maternal chromosome. Therefore, each diploid human cell has four copies of the  $\alpha$ -globin gene. The four  $\alpha$ -thalassemia syndromes thus reflect the disease state produced by deletion or no-function of one, two, three, or all four of the  $\alpha$ -globin genes (Higgs et al., 1989) (Table 1). The silent carrier state of  $\alpha$ -thalassemia represents a mutation of one copy of the  $\alpha$ -globin gene and results in no hematologic abnormalities.

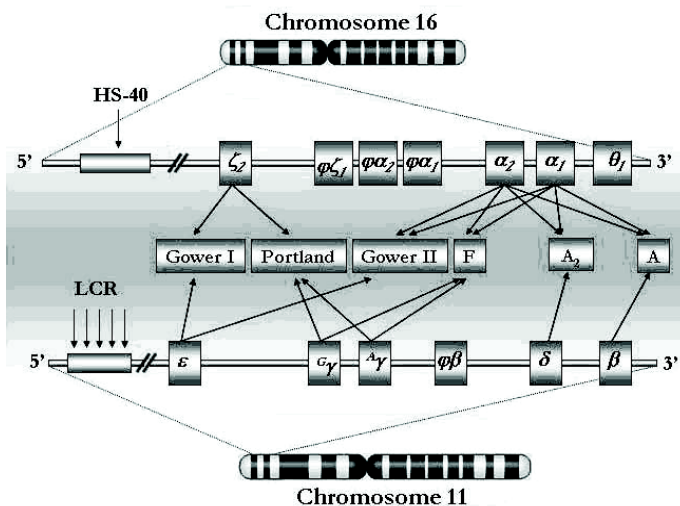

Fig. 2. Schematic represent of the globin gene loci. The upper panel shows the  $\alpha$ -globin locus that resides on chromosome 16. Each of the four alpha globin genes contributed to the synthesis of the  $\alpha$ -globin protein. The lower panel shows the  $\beta$ -globin locus that resides on chromosome 11. The two  $\gamma$ -globin genes are active during fetal growth and produce hemoglobin F. The "adult" gene, beta, takes over after birth

### 3. Geographical distribution of thalassemias and the malaria hypothesis

It is a widely accepted conclusion that the high frequency of thalassemias and sickle cell anemia observed in some tropical and subtropical areas of the world (Fig 3). This due to the resistance against malignant malaria (*Plasmodium falciparum*) conferred by these inherited defects to the heterozygous carriers (Allison, 1954). According to the malaria hypothesis, the heterozygous for HbS or a thalassemic (clinically healthy) are resistant to malaria and have a selective advantage over both homozygotes which have a higher chance of dying during the first years of life because of either malaria or anemia. The preferential survival of the heterozygote thus makes possible the persistence at polymorphic frequencies of the abnormal genes in the population, provided that the selective agent (malaria) remains present and active. Because there is a loss of both normal and abnormal genes, an equilibrium between their frequency will be reached in a period of time which depends on the extent of the selective advantage (balanced polymorphism). The malaria hypothesis is supported by the overlapping geographical distribution of these disorders and endemic malaria and by clinical and epidemiological studies showing a positive correlation between malaria endemicity and frequency of abnormal alleles (Siniscalco et al., 1966).

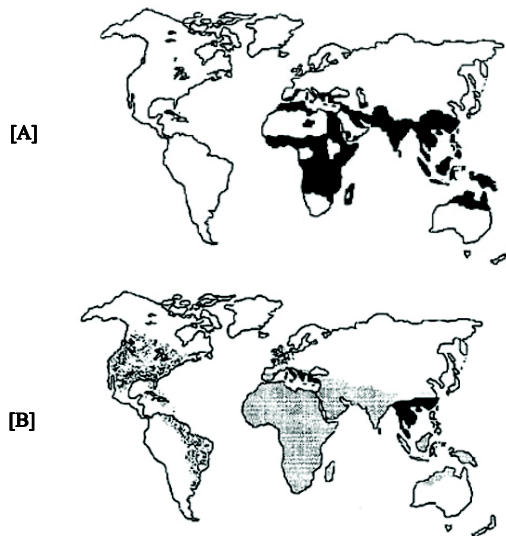

Fig. 3. The geographical distribution of [A] malaria (■) [B] thalassemia (▨,  $\alpha^+$ -thalassemia  $\alpha^0$ -thalassemia). Because of migration, hemoglobinopathies are improved into the area where malaria has never been endemic

The  $\alpha$ -thalassemias are most prevalent in Asian and African populations. Persons of Mediterranean and African descent have the highest incidence of  $\beta$ -thalassemia. Thalassemic mutations have maintained a high frequency, particularly in these areas, because the heterozygous state confers some protection against malaria (Weatherall, 1987). Other abnormalities of hemoglobin also occur with increased frequency in these populations: therefore, thalassemia may coexist with other disorders of hemoglobin such as the sickle cell syndromes, hemoglobin E (Hb-E), or hemoglobin C (Hb-C).

Syndrome	Molecular basis	Laboratory values	Clinical Feature
<b><math>\alpha</math>-Thalassemia</b>			
$\alpha$ -Thalassemia silent carrier	One $\alpha$ - gene deletion ( $-\alpha/\alpha\alpha$ ) Heterozygous $\alpha$ -thalassemia	No anemia or RBC morphology abnormalities; Asymptomatic may have 1-2 % Hb Bart's at birth	Asymptomatic
$\alpha$ -Thalassemia trait (minor)	Two $\alpha$ -gene deletion ( $-\alpha/\alpha\alpha$ ) Heterozygous $\alpha$ -thalassemia-1 Two $\alpha$ -gene deletion ( $-\alpha/-\alpha$ ) Homozygous $\alpha$ -thalassemia 2	Mild anemia, microcytosis, and hypochromia; 4-6% Hb Bart's at birth	Asymptomatic
Hb H disease (Hb variants related to mutation in $\alpha$ -globin chain)	Three $\alpha$ -gene deletion ( $---/\alpha$ ) $\alpha$ -thalassemia-1/ $\alpha$ -thalassemia-2 Hb Constant Spring $\alpha$ -thalassemia-1/Hb Constant Spring	Moderate anemia, microcytosis, hypochromia, RBC fragments; Hb Bart's prominent at birth $\alpha$ - chain has extra 31 amino acids	Jaundice, gallstones, splenomegaly, occasionally need transfusion; antioxidant drugs can precipitate hemolysis
Hb Bart's Hydrops fetalis	Four $\alpha$ -gene deletion ( $----$ ) Homozygous $\alpha$ -thalassemia 1	Severe anemia, nucleated RRCs; only Hb H, Bart's, and Portland present	Death in utero or shortly after birth
<b><math>\beta</math>-Thalassemia</b>			
$\beta$ -Thalassemia trait (minor)	Point mutations Heterozygous $\beta^0$ -thalassemia Heterozygous $\beta^+$ -thalassemia	Mild anemia, hypochromia, and microcytosis; RBC morphologic abnormalities; Hb A <sub>2</sub> , and F often elevated	Asymptomatic
$\beta$ -Thalassemia intermedia	Point mutations - $\beta^0$ -thalassemia/ $\beta^+$ -thalassemia -Hb $\beta^+$ -thalassemia	Moderate anemia, microcytosis, and hypochromia; RBC morphologic abnormalities; Hb A, and F increased; Hb A decreased to absent	Maintain Hb of 7 g/dL without transfusion; clinical phenotype between $\beta$ -thalassemia trait and thalassemia major

Syndrome	Molecular basis	Laboratory values	Clinical Feature
$\beta$ -Thalassemia major	Point mutations -Homozygous $\beta^0$ -thalassemia - HbE $\beta^0$ -thalassemia (Thalassemia intermediate or thalassemia major)	Severe anemia, microcytosis, and hypochromia; RBC fragments and striking morphologic abnormalities; Hb A <sub>2</sub> and F increased; Hb A decreased to absent	Require chronic transfusion; develop iron overload resulting in endocrine abnormalities and chronic organ damage
RBC= red blood cell; Hb H = hemoglobin H			

Table 1. Characteristic of the Thalassemia Syndromes

$\beta$ -thalassemia is prevalent in Mediterranean countries, the Middle East, Central Asia, India, Southern China, and the Far East as well as countries along the north coast of Africa and in South America. The highest carrier frequency is reported in Cyprus (14%), Sardinia (10.3%), and Southeast Asia (Flint et al., 1998). The high gene frequency of  $\beta$ -thalassemia in these regions is most likely related to the selective pressure from *Plasmodium falciparum* malaria (Flint et al., 1998). Population migration and intermarriage between different ethnic groups has introduced thalassemia in almost every country of the world, including Northern Europe where thalassemia was previously absent. It has been estimated that about 1.5% of the global population (80 to 90 million people) are carriers of  $\beta$ -thalassemia, with about 60,000 symptomatic individuals born annually, the great majority in the developing world. The total annual incidence of symptomatic individuals is estimated at 1 in 100,000 throughout the world and 1 in 10,000 people in the European Union. According to Thalassemia International Federation, only about 200,000 patients with thalassemia major are alive and registered as receiving regular treatment around the world (Thalassemia International Federation: Guidelines for the clinical management of thalassemia 2<sup>nd</sup> edition. 2008 (<http://www.Thalassemia.org.cy>)).

#### 4. Molecular basis and classification

The thalassemia syndromes are one of the most thoroughly studied diseases at the molecular level. Consequently, some explanation for the clinical heterogeneity seen in patients can be explained at the molecular level.

##### 4.1 $\alpha$ -Thalassemias

The major clinical syndromes resulting from  $\alpha$ -thalassemia were first recognized in the mid 1950s and early 1960s through the association of the abnormal hemoglobins (Hb-H and Hb Bart's) with hypochromic microcytic anemia in the absence of iron deficiency (Minnich et al., 1954, Rigas et al., 1955), Lie-Injo & Jo, 1960).  $\alpha$ -Thalassemia is divided into deletional and nondeletional types (Bain 2006). There are at least 40 different deletions. The size of the deletion is important and affects the clinical phenotype of hydrops fetalis. Over 95% of  $\alpha$  thalassemia is caused by large deletions involving one or both of the  $\alpha$ -globin genes. The  $\alpha$ -globin gene cluster occurs on the short arm of chromosome 16, band 16 p 13.3 and includes the  $\alpha$ -globin genes as well as the embryonic genes (as two identical  $\alpha$ -globin genes ( $\alpha_1$  and  $\alpha_2$ ) that are aligned one after the other on the chromosome). Common  $\alpha$ -thalassemia deletions that spare the embryonic gene allow for the production of functional embryonic

hemoglobin early in gestation. In contrast, the large deletions (severe) lack the benefit of embryonic hemoglobin. Non-deletion mutations may have a more severe phenotype than most of the deletional mutations. The most common non-deletional  $\alpha$ -thalassemia mutation is Hemoglobin Constant Spring; this mutation of the stop codon results in 31 amino acids being added to  $\alpha$  chain. Depending on the production of  $\alpha$ -globin chains,  $\alpha$ -thalassemia determinants can be classified into two groups:  $\alpha^0$  and  $\alpha^+$ . In  $\alpha^0$ -thalassemia the production of  $\alpha$ -chains by the affected chromosome is completely abolished;  $\alpha^+$ -thalassemia is defined by the variable amounts of  $\alpha$  polypeptide chains which can still be expressed in cis to the thalassaemic cluster. This nomenclature, which describes  $\alpha$ -thalassemias in terms of  $\alpha$ -globin chain expression/haplotype, has replaced the previous classification of these defects into severe ( $\alpha$ -thalassaemia-1) and mild ( $\alpha$ -thalassaemia-2) forms (Weatherall & Clegg, 1981).

In the past, genetics of these syndromes were more confusing. This was because the adult carriers of  $\alpha$ -thalassemia do not produce large amounts of either Hb-H or Hb Bart's. Although the relatives of the affected individuals do not have a readily defined phenotype, it was eventually shown that the offspring of individuals with Hb-H disease have raised levels of Hb Bart's ( $\gamma_4$ ) in the neonatal period (Na-Nakorn et al., 1969), and the parents of individuals with Hb-H disease and the Hb Bart's hydrops fetalis syndrome have mildly hypochromic, microcytic red cell indices (Ali, 1969); sometimes Hb-H inclusions could be demonstrated in occasional red cells (McNeil JR, 1968). By 1969 it had been shown that Hb-H disease results from the inheritance of  $\alpha$ -thalassemia-1 x  $\alpha$ -thalassemia-2 and the Hb Bart's hydrops fetalis syndrome results from  $\alpha$ -thalassemia-1 x  $\alpha$ -thalassemia 1) (Na-Nakorn et al., 1969, Pootrakul et al., 1967).

The structural organization of the  $\alpha$ -globin genes revealed by blot hybridization analysis (Orkin, 1978), Normal individual have two  $\alpha$ -genes on each chromosome 16 or four copies of the  $\alpha$ -globin gene ( $\alpha\alpha/\alpha\alpha$ ) and carriers for  $\alpha$ -thalassemia have either three ( $-\alpha/\alpha\alpha$ ) or two ( $- -/\alpha\alpha$ )  $\alpha$  genes. Thus, the most frequently encountered genotype of Hb-H disease is  $- -/ - \alpha$  and Hb Bart's hydrops fetalis is  $- -/ - -$  (Orkin, 1978, Orkin et al., 1979, Phillips 3d et al., 1980). Thus by 1980 the molecular genetics of  $\alpha$ -thalassemia was understood. The four  $\alpha$ -thalassemia syndromes thus reflect the disease state produced by deletion or nonfunction of one, two, three, or all four of the  $\alpha$ -globin genes (Higgs et al., 1989).  $\alpha$ -Thalassemia trait occurs with deletion or nonfunction of two  $\alpha$ -globin genes. The two genes are deleted from the same chromosome (cis-deletion) or one gene is lost from each chromosome 16 (trans-deletion). The cis-deletion is most common in Asian and Mediterranean populations, whereas individuals of African descent usually have the trans-deletion (Higgs et al., 1989). Both varieties of  $\alpha$ -thalassemia trait produce an asymptomatic, mild anemia associated with microcytosis. Hemoglobin H (Hb-H) disease, a three-gene deletion, usually results from inheritance of the cis  $\alpha$ -thalassemia trait from one parent and the one gene deletion from the other parent. Therefore, this abnormality is rare in the black population because the cis-deletion is uncommon. Hydrops fetalis results from deletion of all four  $\alpha$ -globin genes and generally causes death in utero because no physiologically useful hemoglobin is produced beyond the embryonic stage. Although the  $\alpha$ -thalassemia syndromes also are of varying clinical severity, these differences cannot be explained by the number of deleted or nonfunctional genes. One of the most frequent  $\alpha$ -thalassemia mutations is the  $- -^{SEA}$  deletion, which deletes both  $\alpha$ -globin genes but spares the embryonic gene. Homozygosity for this deletion ( $- -^{SEA}$ ) is the most common cause of hydrops fetalis (Chui & Wayne 1998). The sparing of the embryonic gene allows enough functional embryonic hemoglobin (Hemoglobin Portland 1 and Hemoglobin Portland 2) to allow gestation to continue and the

phenotype of hydrops fetalis to develop. In contrast, other common  $\alpha$ -thalassemia mutations ( $-\text{FIL}$ ,  $-\text{THAI}$ ) also lack the entire embryonic  $\alpha$ -globin cluster, and therefore do not produce the functional embryonic Hemoglobin Portland. These embryos may terminate unnoticed early in gestation (Chui & Waye 1998). Over 5% of individuals in the Philippines are carriers for the  $-\text{SEA}$  or  $-\text{FIL}$  mutation. Hydrops fetalis, while most common in Southeast Asia, is found worldwide among many ethnic groups;  $-\text{MED}$  is a common  $\alpha^0$ -thalassemia mutation in Mediterranean regions, particularly Greece and Cyprus. It has resulted in hydrops fetalis. Non-deletional  $\alpha$ -thalassemia is found throughout the world. Up to 8% of Southeast Asians are carriers of Hemoglobin Constant Spring. In the Middle East, Hemoglobin  $\alpha^{\text{TSaudi}}$  is a common  $\alpha$ -thalassemia non-deletional mutation. It is a mutation of the polyadenylation signal sequence of the  $\alpha 2$  gene, resulting in decreased expression of structurally normal  $\alpha$  chains. Hemoglobin Koya Dora, another structural non-deletional mutation, is found in India. Other structural mutations, such as hemoglobin Quong Sze found in Southeast Asia, are highly unstable and result in defects in the hem pocket (Skordis, 2006, Leung et al., 2002).

#### 4.2 $\alpha$ Thalassemia trait

$\alpha$ -Thalassaemia trait is usually caused either by the interaction of the normal haplotype with a  $\alpha^0$ - or a  $\alpha^+$ -thalassaemia determinant or by the homozygosity for two  $\alpha^+$  haplotypes. Much less frequently this phenotype can be the result of compound heterozygosity for a deletional  $\alpha^+$ -thalassaemia and a  $\alpha^+$  determinant caused by a point mutation or even homozygosity for the latter kind of determinant. Depending on the nature and localization of the mutation, the phenotype of the trait can thus range from the silent carrier to individuals showing very pronounced haematological abnormalities.

Patients with  $\alpha$ -thalassemia trait have microcytosis, hypochromia, and mild anemia. Small amounts of hemoglobin Bart's (a tetramer of  $\gamma$  chains:  $\gamma_4$ ) may be noted on a newborn screen. Individuals with this disorder are asymptomatic and do not require transfusions or any other treatment. The diagnosis of  $\alpha$ -thalassemia trait is considered when the patient has the appropriate RBC abnormalities, when iron deficiency and  $\beta$ -thalassemia trait have been excluded, and when family studies (CBC, hemoglobin profile, and review of the peripheral smear) are consistent with the diagnosis (Nathan & Oski 1993). To make the diagnosis with complete certainty requires characterization of gene deletions with restriction endonuclease mapping or globin chain synthesis studies showing a decreased ( $\alpha:\beta$ ) ratio. However, this confirmation rarely is indicated clinically.

#### 4.3 Hemoglobin H disease

Hemoglobin H (Hb-H) disease is the most severe non-fatal form of  $\alpha$ -thalassemia syndrome, mostly caused by molecular defects of the  $\alpha$ -globin genes in which  $\alpha$ -globin expression is decreased, causes a moderate anemia with hypochromia, microcytosis, and red cell fragmentation. Two common genotypes lead to the phenotype of Hb-H disease are  $\alpha$ -thalassemia-1/ $\alpha$ -thalassemia-2 and Hb Constant Spring/ $\alpha$ -thalassemia-1. Both genotypes are equally common but Hb Constant Spring/ $\alpha$ -thalassemia-1 is more severe than  $\alpha$ -thalassemia-1/ $\alpha$ -thalassemia-2 (Fucharoen et al., 1988). Compound heterozygotes for  $\alpha^0$ - and  $\alpha^+$ -thalassemia ( $-\text{}/-\text{}$ ) with only one functional  $\alpha$ -globin gene have a severe imbalance in globin chain synthesis with a two- to five-fold excess of  $\beta$ -globin chains synthesis (Nathan & Oski 1993). Newborns have large amounts of Bart's Hb. (Higgs et al., 1989). When the switch from  $\gamma$ - to  $\beta$ -globin chain production occurs, Hb Bart's ( $\gamma_4$ ) switches to Hb-H ( $\beta_4$ ) and the typical picture of Hb-H disease results. The excess  $\beta$ -globin chains precipitate and form a characteristic



abnormal hemoglobin; hemoglobin H (Hb-H) or  $\beta$ -globin tetramer ( $\beta_4$ ). This causes a phenotype of mild to moderate chronic hemolytic anemia named Hb-H disease characterized by readily detectable Hb-H inclusion bodies in the peripheral blood cells. Hb-H is unable to transport oxygen at physiologic conditions; therefore, patients have a more severe deficit in oxygen carrying capacity than would be expected from their measured hemoglobin level (Nathan & Oski 1993). Increased red cell destruction occurs because Hb-H containing cells are sensitive to oxidative stress. Thus the complications of the disease are related to hemolysis and include jaundice, hepatosplenomegaly, gallstones, and leg ulcers. Most affected individuals have a mild disorder with an Hb concentration of 7-10 g/dL and require only symptomatic care with occasional transfusions. Therefore, iron overload is rarely a problem in these patients.

The clinical phenotypes of Hb-H disease found in nondeletional  $\alpha$ -thalassemia ( $--/\alpha T\alpha$ ) are often more severe than those caused by  $\alpha^+$ -thalassemia resulting from simple deletion ( $--/-\alpha$ ). Recent molecular analysis of more than 500 thalassemia carriers at the Department of Pediatrics, Siriraj Hospital, Thailand, revealed that the frequency of deletional  $\alpha$ -thalassemia is significantly higher compared with non-deletional mutations (mainly Hb CS and Pakse) in Thai population (15%-20% vs 1%-2%, respectively). However, the number of symptomatic patients with Hb-H disease due to non-deletional mutations appeared to be higher than those with deletional Hb-H (60% vs 40% from 350 Hb-H disease patients), as shown in Table 1, suggesting that non-deletional Hb-H patients have more significant clinical symptoms and require more medical attention (Fucharoen & Viprakasit, 2009).

A striking clinical feature of Hb-H disease is the sudden drop in the Hb concentration with associated symptoms of acute anemia during episodes of pyrexia (Chinprasertsuk et al., 1994). It has been postulated that fever either alone or together with oxidative substances released in the process of infection, induces the unstable Hb-H to precipitate in the red cells as inclusion bodies. These red cells then either hemolyze or are rapidly destroyed by the reticuloendothelial cells. Blood transfusions should be given together with treatment for infections. Body temperature should be normalized as quickly as possible in order to reduce induction of Hb-H precipitation within the red cells. Hb Constant Spring is detected in addition to Hb-A and H in patients with Hb Constant Spring  $\alpha$ -thalassemia-1. They are slightly more severe than classical Hb-H disease with lower Hb concentrations, larger spleens, higher levels of Hb-H and more red cells containing inclusion bodies (Fucharoen et al., 1988).

#### 4.4 Hemoglobin Bart's Hydrops fetalis syndrome

Hydrops fetalis, the most severe form of  $\alpha$ -thalassemia, occurs in infants whose parents both have  $\alpha$ -thalassemia syndrome (Higgs et al., 1989). As discussed previously, these infants have deletion of all four  $\alpha$ -globin genes and produce only Hb Bart's, Hb-H, and small amounts of embryonic hemoglobins. Therefore, they have very little physiologically useful hemoglobin and are hydropic secondary to severe anemia. These infants are usually stillborn or die shortly after delivery (Chui & Wayne, 1998, Leung et al., 2008, Lorey et al., 2001, Michlitsch et al., 2009, Weatherall 2008). Advances in perinatal care and recognition of surviving homozygous thalassemia newborns have precipitated studies of long-term survivors with this disorder. Recently, the Newborn Screening Program of California reported 8 surviving  $\alpha$ -thalassemia major newborns along with 500 Hemoglobin H babies (Michlitsch et al., 2009). In southern China, the prevalence of  $\alpha^0$ -thalassemia trait is 8.5% and 0.23% of births had homozygous  $\alpha$ -thalassemia (Chui & Wayne, 1998). In addition to China and Southeast Asia, Bart's hydrops fetalis is now being recognized in Greece, Turkey, Cyprus, India, Sardinia, and other parts of the world (Chui & Wayne 1998, Yang & Li, 2009, Suwanrath-Kengpol et al., 2005)

Clinical and haematological examinations reveal severely anaemic infants with variable hemoglobin levels (3-10g/dl) and marked anisopoikilocytosis with large hypochromic red cells and with the presence of numerous erythroblasts. The analysis of the hemolysate shows, in the hydrops caused by the deletion of four  $\alpha$  genes, about 80% Hb Bart's ( $\gamma_4$ ) and 20% Hb Portland 1 ( $\zeta_2 \gamma_2$ ) with very small amounts, if any, of Hb Portland 2 ( $\zeta_2 \beta_2$ ) and HbH ( $\beta_4$ ) (Kutlar et al., 1989). Lower levels of Hb Portland 1 have been observed in genetic compounds for the SEA deletion and the large Fil deletion which also eliminates the  $\zeta$  gene (Kutlar et al., 1989). In the rare cases of Hb-H disease with hydrops fetalis, in addition to Hb Bart's and the embryonic Hb Portland 1 and 2, variable amounts of HbH, HbF and HbA can also be detected (Chan et al., 1997). The lack of hem-hem interaction or Bohr effect and binds oxygen irreversibly tightly and high oxygen affinity of Hb Bart's make this  $\gamma$  tetramer unsuitable for the delivery of oxygen to the tissues. The ensuing hypoxia is the cause of fetal hydrops and intrauterine death caused by massive organomegaly, severe albuminemia, and heart failure. This leads to gross body edema, growth failure.

#### 4.5 $\beta$ -Thalassemias

The  $\beta$ -thalassemias are widespread throughout the Mediterranean region, Africa, the Middle East, the Indian subcontinent and Burma, Southeast Asia including southern China, the Malay Peninsula, and Indonesia. Estimates of gene frequencies range from 3 to 10 percent in some areas. (Weatherall, 1994) Within each population at risk for  $\beta$ -thalassemia a small number of common mutations are found, as well as rarer ones; each mutation is in strong linkage disequilibrium with specific arrangements of restriction-fragment length polymorphisms, or haplotypes, within the  $\beta$ -globin cluster. A limited number of haplotypes are found in each population, so that 80 percent of the mutations are associated with only 20 different haplotypes. This observation has helped demonstrate the independent origin of  $\beta$ -thalassemia in several populations (Flint et al., 1993). There is evidence that the high frequency of  $\beta$ -thalassemia throughout the tropics reflects an advantage of heterozygotes against *Plasmodium falciparum* malaria, (Weatherall, 1987) as has already been demonstrated in  $\alpha$ -thalassemia (Allen et al., 1997).

The  $\beta$ -globin gene cluster is located on chromosome 11 and is not duplicated like the  $\alpha$ -globin genes. Therefore, each diploid cell contains only two  $\beta$ -globin genes. Mutations are described that affect every step in the process of gene expression from transcription and translation to post-translational stability of the  $\beta$ -globin chain (Kazazian Jr., 1990) The variable clinical severity of the  $\beta$ -thalassemia syndromes depends on how significantly these different mutations affect  $\beta$ -globin synthesis. Although over ninety such mutations are known, a given mutation generally is found in one ethnic group and not another. Nearly 200 different mutations have been described in patients with  $\beta$ -thalassemia and related disorders. Although most are small nucleotide substitutions within the cluster, deletions may also cause  $\beta$ -thalassemia (Weatherall 1994). All the mutations result in either the absence of the synthesis of  $\beta$ -globin chains ( $\beta^0$ -thalassemia) or a reduction in synthesis ( $\beta^+$ -thalassemia) (Fig. 2). Mutations in or close to the conserved promoter sequences and in the 5' untranslated region down-regulate transcription, usually resulting in mild  $\beta^+$ -thalassemia. Transcription is also affected by deletions in the 5' region, which completely inactivate transcription and result in  $\beta^0$ -thalassemia. Both splicing of the messenger RNA (mRNA) precursor and ineffective cleavage of the mRNA transcript are result in  $\beta$ -thalassemia. In some mutations, no normal message is produced, whereas other mutations

only slightly reduce the amount of normally spliced mRNA. Mutations within invariant dinucleotides at intron-exon junctions, critical to the removal of intervening sequences and the splicing of exons to produce functional mRNA, result in  $\beta^0$ -thalassemia. Mutations in highly conserved nucleotides flanking these sequences, or in "cryptic" splice sites, which resemble a donor or acceptor splice site, result in severe as well as mild  $\beta^+$ -thalassemia. Substitutions or small deletions affecting the conserved AATAAA sequence in the 3' untranslated region result in ineffective cleavage of the mRNA transcript and cause mild  $\beta^+$ -thalassemia. Mutations that interfere with translation involve the initiation, elongation, or termination of globin-chain production and result in  $\beta^0$ -thalassemia. Approximately half of all  $\beta$ -thalassemia mutations interfere with translation; these include frame-shift or nonsense mutations, which introduce premature termination codons and result in  $\beta^0$ -thalassemia. A more recently identified family of mutations, usually involving exon 3, results in the production of unstable globin chains of varying lengths that, together with a relative excess of  $\alpha$ -globin chains, precipitate in red-cell precursors and lead to ineffective erythropoiesis, even in the heterozygous state. This is the molecular basis for dominantly inherited ( $\beta^+$ ) thalassemia. In addition, missense mutations, resulting in the synthesis of unstable  $\beta$ -globin chains, cause  $\beta$ -thalassemia.  $\beta$ -thalassemia includes three main forms: Thalassemia Major, variably referred to as Cooley's Anemia and Mediterranean Anemia, Thalassemia Intermedia and Thalassemia Minor also called "  $\beta$ -thalassemia carrier", " $\beta$ -thalassemia trait" or "heterozygous  $\beta$ -thalassemia". According to Thalassemia International Federation, only about 200,000 patients with thalassemia major are alive and registered as receiving regular treatment around the world (Thalassemia International Federation: Guidelines for the clinical management of thalassemia 2nd edition. 2008 [<http://www.thalassemia.org.cy>]). The most common combination of  $\beta$ -thalassemia with abnormal Hb or structural Hb variant with thalassemic properties is  $\beta$ -thalassemia/Hb-E which is most prevalent in Southeast Asia where the carrier frequency is around 50%.

#### 4.6 $\beta$ -Thalassemia trait

Carriers of thalassemia, individuals with this disorder are heterozygous for a mutation that affects  $\beta$ -globin synthesis (Kazazian Jr., 1990). They are mildly anemic with hypochromic, microcytic RBCs. Targeting and elliptocytosis are often seen. As with  $\alpha$ -thalassemia trait, one must exclude iron deficiency to make the diagnosis. In general, patients with  $\beta$ -thalassemia trait have a lower mean corpuscular volume (MCV) and a higher red cell count for the degree of anemia than seen in iron deficiency. Thus, the Mentzer index (MCV/RBC) is useful as a screening test to differentiate thalassemia from iron deficiency. If the Mentzer index is  $< 13$ , thalassemia is more likely; if  $> 13$ , iron deficiency is more common. Hb electrophoresis is normal with iron deficiency, but with  $\beta$ -thalassemia trait the hemoglobin A<sub>2</sub> (Hb A<sub>2</sub>) is often elevated. Globin chain synthesis studies show an excess of  $\alpha$ -chains (Nathan & Oski 1993). These patients need no treatment, but should receive genetic counseling regarding the potential for having a child with  $\beta$ -thalassemia major or a combination of  $\beta$ -thalassemia trait and sickle hemoglobin (S $\beta$ -thal). When both parents are carriers there is a 25% risk at each pregnancy of having children with homozygous thalassemia. Within the first months of life, adult hemoglobin containing 2 pairs of  $\alpha$  and  $\beta$ -chain (Hb-A:  $\alpha_2\beta_2$ ) physiologically replaces fetal hemoglobin (HbF:  $\alpha_2\gamma_2$ ). In  $\beta$ -thalassemia, deficient of production structurally normal  $\beta$ -chain lead to anemia, largely as a consequence of ineffective hemopoiesis (Olivieri 1999, Nathan & Gunn, 1966).

#### 4.7 Thalassemia intermedia

These  $\beta$ -thalassemia patients who clinically are between the extremes of thalassemia trait and thalassemia major (Nathan & Oski 1993), have milder anemia and by definition do not require or only occasionally require transfusion. The regular transfusion therapy is not required initially. These patients usually maintain a hemoglobin level of 7 g/dL without transfusions. At the severe end of the clinical spectrum, patients present between the ages of 2 and 6 years and although they are capable of surviving without regular blood transfusion, growth and development are retarded. At the other end of the spectrum are patients who are completely asymptomatic until adult life with only mild anemia. Therefore, pregnant or older patients are less able to tolerate the anemia and may need transfusion support. Hypertrophy of erythroid marrow with the possibility of extramedullary erythropoiesis, a compensatory mechanism of bone marrow to overcome chronic anemia, is common. Its consequences are characteristic deformities of the bone and face, osteoporosis with pathologic fractures of long bones and formation of erythropoietic masses that primarily affect the spleen, liver, lymph nodes, chest and spine. Enlargement of the spleen is also a consequence of its major role in clearing damaged red cells from the bloodstream.

#### 4.8 $\beta$ -Thalassemia major (Cooley's anemia)

A Detroit pediatrician, Thomas Cooley, first described this disorder in 1925 after noticing similarities in the appearance and clinical findings in several anemic children of Greek and Italian immigrants (Cooley et al., 1927). Prior to the advent of routine transfusion therapy,  $\beta$ -thalassemia major patients did not survive beyond the first few years of life. Survival is now improved with hypertransfusion regimens, iron chelation therapy, and bone marrow transplantation. Serious thalassemia is associated with iron overload, tissue damage, and increased risk of cardiovascular complications.  $\beta$ -Thalassemias are the most important among the thalassemia syndromes with an average trait prevalence of 7% in Greece, 15% among Cypriots, and 4.8% in Thailand (Weatherall, 1998, Weatherall & Clegg, 2001).

Clinical presentation of thalassemia major occurs between 6 and 24 months. Affected infants fail to thrive and become progressively pale. Feeding problems, diarrhea, irritability, recurrent bouts of fever, and progressive enlargement of the abdomen caused by spleen and liver enlargement may occur. In some developing countries, where due to the lack of resources patients are untreated or poorly transfused, the clinical picture of thalassemia major is characterized by growth retardation, pallor, jaundice, poor musculature, genu valgum, hepatosplenomegaly, leg ulcers, development of masses from extramedullary hematopoiesis, and skeletal changes resulting from expansion of the bone marrow. Skeletal changes include deformities in the long bones of the legs and typical craniofacial changes (bossing of the skull, prominent malar eminence, depression of the bridge of the nose, tendency to a mongoloid slant of the eye, and hypertrophy of the maxillae, which tends to expose the upper teeth).

In  $\beta$ -thalassemia major, severity of anemia requires initiation of blood transfusions during infancy. If a regular transfusion program that maintains a minimum Hb concentration of 9.5 to 10.5 g/dL is initiated, growth and development tends to be normal up to 10 to 12 years (Thalassemia International Federation: Guidelines for the clinical management of thalassemia 2<sup>nd</sup> edition. 2008 (<http://www.thalassemia.org.cy>)). Transfused patients may develop complications related to iron overload. Complications of iron overload in children include growth retardation and failure or delay of sexual maturation. Later iron overload-related complications include involvement of the heart (dilated cardiomyopathy or

rarely arrhythmias), liver (fibrosis and cirrhosis), and endocrine glands (diabetes mellitus, hypogonadism and insufficiency of the parathyroid, thyroid, pituitary, and, less commonly, adrenal glands) (Borgna-Pignatti & Galanello, 2004).

#### **4.9 Hemoglobin E (Hb-E)**

The most common combination of  $\beta$ -thalassemia with abnormal Hb or structural Hb variant with thalassemic properties is Hb-E/ $\beta$ -thalassemia which is most prevalent in an area stretching from northern India and Bangladesh, through Laos, Cambodia, Thailand, Vietnam, Malaysia, the Philippines, and Indonesia where the carrier frequency is around 50%. Hb-E is caused by a mutation of the 26<sup>th</sup> amino acid of a normal  $\beta$ -chain, glutamine, is replaced by lysine. This mutation also activates a cryptic synthesis of the  $\beta$ -globin chain and leads to a thalassemic phenotype. Furthermore, the hemoglobin E gene, which can interact with  $\beta$ -thalassemic alleles and cause a broad phenotypic spectrum, reaches a frequency of up to 50% in Thailand (Weatherall 1998). These Hb-E/ $\beta$ -thalassemias may be identified to three categories depending on the severity of symptoms:

#### **4.10 Mild Hb-E/ $\beta$ -thalassemia**

It is observed in about 15% of all cases in Southeast Asia. This group of patients maintains Hb levels between 9 and 12 g/dl and usually does not develop clinically significant problems. No treatment is required.

#### **4.11 Moderately severe Hb-E/ $\beta$ -thalassemia**

The majority of Hb-E/ $\beta$ -thalassemia cases fall into this category. The Hb levels remain at 6-7 g/dl and the clinical symptoms are similar to thalassemia intermedia. Transfusions are not required unless infections precipitate further anemia. Iron overload may occur.

#### **4.12 Severe Hb-E/ $\beta$ -thalassemia**

The Hb level can be as low as 4-5 g/dl. Patients in this group manifest symptoms similar to thalassemia major and are treated as thalassemia major patients.

Hb-E/ $\beta$ -thalassemia is more frequent than homozygous  $\beta$ -thalassemia in Thailand because of the high frequency of Hb-E (Fucharoen & Winichagoon, 2000) It is the most common severe thalassemia syndrome in adults. There are two types of Hb-E/ $\beta$ -thalassemia, classified based on the presence or absence of Hb-A, Hb-E/ $\beta^+$ -thalassemia and Hb-E/ $\beta^0$ -thalassemia. In patients with Hb-E/ $\beta^0$ -thalassemia, only Hb-E and Hb-F are present without detectable Hb-A. Hb-E constitutes between 40-60% of the hemoglobin with the rest Hb-F. Hb-A is present in Hb-E/ $\beta^+$ -thalassemia, resulting in a milder clinical picture than Hb-E/ $\beta^0$ -thalassemia. Since Hb-E/ $\beta$ -thalassemia is unique to Southeast Asia in general and to Thailand in particular, details of clinical manifestations as well as variability in disease severity will be discussed. In addition, as population migrations have caused the demography of the disease to shift worldwide, this thalassemia syndrome currently has more global implications.

### **5. Management of $\beta$ -thalassemia major**

#### **5.1 Transfusions**

Goals of transfusion therapy are the primary means of treatment for patients with severe  $\beta$ -thalassemia (Fosburg & Nathan 1990) for correction of anemia, suppression of

erythropoiesis and inhibition of gastrointestinal iron absorption, which occurs in non transfused patients as a consequence of an increased ineffective erythropoiesis. The decision to start transfusion in patients with confirmed diagnosis of thalassemia should be based on the presence of severe anemia (Hb < 7 g/dl for more than two weeks, excluding other contributory causes such as infections). However, also in patients with Hb > 7 g/dl, other factors should be considered, including facial changes, poor growth, evidence of bony expansion and increasing splenomegaly. Post-transfusion Hb level of 9 to 10 g/dl - 13 to 14 g/dl prevents growth impairment, organ damage and bone deformities, allowing normal activity and quality of life (Thalassemia International Federation: Guidelines for the clinical management of thalassemia 2nd edition. 2008 [<http://www.thalassemia.org.cy>], Borgna-Pignatti & Galanello, 2004). The frequency of transfusion is usually every two to four weeks. Shorter intervals might further reduce the overall blood requirement, but are incompatible with an acceptable quality of life. The amount of blood to be transfused depends on several factors including weight of the patient, target increase in Hb level and hematocrit of blood unit. Appropriate graphs and formulae to calculate the amount of blood to be transfused are available (Thalassemia International Federation: Guidelines for the clinical management of thalassemia 2nd edition. 2008 [<http://www.thalassemia.org.cy>]). In general, the amount of transfused RBC should not exceed 15 to 20 ml/kg/day, infused at a maximum rate of 5 ml/kg/hour, to avoid a fast increase in blood volume. To monitor the effectiveness of transfusion therapy, some indices should be recorded at each transfusion, such as pre- and posttransfusion Hb, amount and hematocrit of the blood unit, daily Hb fall and transfusional interval. These measurements enable two important parameters to be calculated: red cell requirement and iron intake. Hypertransfusion and iron chelation is the standard therapy for thalassemia major. These transfusion regimens will provide a marked improvement in survival, growth and sexual development, prevent disfiguring bony abnormalities, decrease cardiac effort, and limit the development of hepatosplenomegaly. The red blood cell transfusions are lifesavers for patients with thalassemi. They are responsible for a series of inevitable complications and expose the patients to a variety of risks of long term transfusion therapy is iron overload.

## 6. Complications

In developed countries, patients are now given routine transfusion therapy, which has lengthened survival and altered the clinical course of the disease. Assessment and treatment of iron overload patients maintained on a regular transfusion regimen progressively develop clinical manifestations of iron overload. Iron overload of tissue is fatal with or without transfusion if not prevented or adequately treated. It is the most important complication of  $\beta$ -thalassemia and is a major focus of management (Olivieri & Brittenham 1997). Iron status should be accurately assessed in order to evaluate its clinical relevance, the need for treatment, and the timing and monitoring of chelation therapy. The iron status of multitransfused patients can be assessed by several methods. Serum ferritin has in general been found to correlate with body iron stores (Brittenham et al., 1993). After approximately one year of transfusions, iron begins to be deposited in parenchymal tissues (Risdon et al., 1973), where it may cause substantial toxicity as compared with that within reticuloendothelial cells (Hershko & Weatherall 1988, Hershko et al., 1998) Morbidity and mortality are now the result of chronic transfusion induced iron overload and most patients die of heart dysfunction of iron deposition (Zurlo et al., 1989). Iron accumulation in the liver causes fibrosis and cirrhosis (Fosburg & Nathan, 1990). Endocrine abnormalities related to iron overload include

diabetes mellitus and impaired glucose tolerance, adrenal insufficiency, hypothyroidism, osteoporosis, hypoparathyroidism and hypogonadism (Fosburg & Nathan, 1990).

In the presence of excess metal iron can generate reactive oxygen species (ROS) (Stohs & Bagchi, 1995) that can modify oxidant-mediated intracellular signaling and cause oxidative damage to lipids, protein, and DNA. A well-studied physiologic biochemical iron reacts with  $O_2$  species through the Fenton and Haber-Weiss reactions to form cytotoxic hydroxyl radicals. In this reaction, ferrous ( $Fe^{2+}$ ) iron reacts with hydrogen peroxide to produce ferric ( $Fe^{3+}$ ) iron and highly reactive hydroxyl radicals. This reaction is of particular importance in the liver because this organ, like the heart, has high steady-state production of  $O_2$  and  $H_2O_2$  from abundant mitochondrial activity (Eaton & Qian 2002). In addition to reacting with  $H_2O_2$ , ferrous iron may react with  $O_2$  to produce ferric iron and a superoxide radical. The superoxide radical may engage in a series of reactions to generate hydrogen peroxide, which may serve as a substrate in the Fenton reaction to further result in the production of hydroxyl radicals. The hydroxyl radical can non-selectively attack proteins, nucleic acids, polysaccharides and lipids. Indeed, the production of hydroxyl radicals has been demonstrated in rats exhibiting iron overload (Kadiiska et al., 1995).

As indicate iron

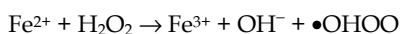
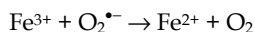

**Net reaction:**



These free radicals cause oxidative damage via lipid peroxidation, DNA hydroxylation, and protein oxidation (Schaible & Kaufmann 2004). Oxidative stress is another prominent mechanism of vasculopathy. In hemolytic disorders, the erythrocyte may be a major determinant of the global redox environment. The thalassemias have increased concentrations of ROS compared with normal red blood cells (Aslan & Freeman, 2004, Hebbel et al., 1982, Chakraborty & Bhattacharyya, 2001). Overproduction of ROS, such as superoxide, by both enzymatic (Xanthine oxidase, NADPH oxidase, uncoupled eNOS) and nonenzymatic pathways (Fenton chemistry), promotes intravascular oxidant stress that can likewise disrupt NO homeostasis and produce the highly oxidative peroxynitrite (Wood et al., 2008). Alters cell membrane lipids and abnormal erythrocyte phosphatidylserine (PS) exposure triggered in part by oxidative stress may also contribute to the early demise of the red blood cell in circulation, making them more vulnerable to enzymatic breakdown by secretory phospholipase A2, an important lipid mediator in inflammation. PS exposure also induces binding of red cells to endothelial cells, leading to sequestration of PS-exposing cells in peripheral blood vessels. This process can contribute to vascular dysfunction, hemolysis, and a pro-thrombotic state (Neidlinger et al., 2006). In the alterations in glutathione buffering system common to these hemoglobinopathies (Chakraborty & Bhattacharyya, 2001, Chakraborty & Bhattacharyya, 2001, Reid et al., 2006) may render erythrocytes incapable of handling the increased oxidant burden, thereby predisposing them to hemolysis. Hydroxyl radical formed by iron catalyzed reactions reacts with a polyunsaturated fatty acid of a membrane lipid caused lipid peroxidation. The resulting lipid hydroperoxides can affect membrane fluidity and membrane protein function. A large number of lipid breakdown products are generated including malondialdehyde (MDA) and 4-hydroxy-2-nonenal (4-HNE). In rat models of iron overload, lipid peroxidation has been found in whole liver and also in isolated cellular fractions including mitochondria, microsomes and lysosomes (Bacon et al., 1983, Britton et al., 1987). The reactive aldehydes

(MDA and HNE) can react with proteins to form adducts. The MDA and HNE-lysine adducts have been found in hepatocytes and plasma from rats fed a diet containing carbonyl iron for 13 weeks (Houglum et al., 1990).

Iron overload causes vitamin C to be oxidized at an increased rate, leading to vitamin C deficiency in these patients. Vitamin C in children <10 years and 100 mg >10 years at the time of DFO infusion may increase the chelatable iron available in the body, thus increasing the efficacy of chelation. However there is currently no evidence supporting the use of vitamin C supplements in patients on DFP, DFX or combination treatment. Vitamin C may increase iron absorption from the gut, labile iron and hence iron toxicity and may therefore be particularly harmful to patients who are not receiving DFO, as iron mobilized by the vitamin C will remain unbound, causing tissue damage. The effectiveness and safety of vitamin E supplementation in thalassemia major has not been formally assessed and it is not possible to give recommendations about its use at this time.

## 7. Assessment of iron overload

Patients maintained on a regular transfusion regimen progressively develop clinical manifestations of iron overload: hypogonadism (35-55% of the patients), hypothyroidism (9-11%), hypoparathyroidism (4%), diabetes (6-10%), liver fibrosis, and heart dysfunction (33%) (Cunningham et al., 2004, Borgna-Pignatti et al., 2004). Iron status should be accurately assessed in order to evaluate its clinical relevance, the need for treatment, and the timing and monitoring of chelation therapy. The iron status of multitransfused patients can be assessed by several methods. Serum ferritin has in general been found to correlate with body iron stores (Brittenham et al 1993). However, as a single value it is not always reliable because, being an acute phase reactant, it is influenced by other factors such as inflammatory disorders, liver disease, malignant. Despite this, serial measurements of serum ferritin remain a reliable and the easiest method to evaluate iron overload and efficacy of chelation therapy. Determination of liver iron concentration in a liver biopsy specimen shows a high correlation with total body iron accumulation and is considered the gold standard for the evaluation of iron overload (Angelucci et al., 2000). However, liver biopsy is an invasive technique with the possibility (though low) of complications. Moreover, we should consider that the presence of hepatic fibrosis, which commonly occurs in individuals with iron overload and HCV infection, and heterogeneous liver iron distribution can lead to possible false negative results (Villeneuve et al., 1996). In recent years, nuclear magnetic resonance imaging (MRI) techniques for assessing iron loading in the liver and heart have been introduced (Wood et al., 2004, Tanner et al., 2006). R2 and T2\* parameters have been validated for liver iron concentration. Cardiac T2\* is reproducible, transferable between different scanners, correlates with cardiac function, and relates to tissue iron concentration.

As the body has no effective means for removing iron, the only way to remove excess iron is to use iron binders (chelators), which allow iron excretion through the urine and/or stool. As a general rule, patients should start iron chelation treatment once they have had 10-20 transfusions or when ferritin levels rise above 1000 ng/ml (Thalassemia International Federation: Guidelines for the clinical management of thalassemia 2nd edition. 2008 [<http://www.thalassemia.org.cy>]). Chelation of iron with desferoxamine is effective in reducing iron load and extending life expectancy. However, to be effective, this drug must be given by subcutaneous continuous infusion each day and is not without side effects including hearing and visual loss (Fosburg & Nathan, 1990). Several oral agents for chelation are in various stages of testing and, if effective, will improve the quality of life for



chronically transfused patients (Nathan & Piomelli 1990). Other therapies such as splenectomy and vitamin and folic acid supplements are also of benefit.

The first drug available for treatment of iron overload was deferoxamine (DFO), an exadentate iron chelator that is not orally absorbed and usually as a subcutaneous 8- to 12-hour nightly infusion, 5-7 nights a week. Average dosage is 20-40 mg/kg body weight for children and 30-50 mg/kg body weight for adults (Thalassemia International Federation: Guidelines for the clinical management of thalassemia 2nd edition, 2008 [<http://www.thalassemia.org.cy>], Borgna-Pignatti & Galanello, 2004). In high risk cases, continuous administration of DFO via an implanted delivery system (Port-acath) or subcutaneously, at doses between 50 and 60 mg/ kg per day, were the only options to intensify the chelation treatment before the advent of the combined therapy with DFO and deferiprone (Anderson et al., 2004). Implanted delivery systems are associated with risk of thrombosis and infection. With DFO, iron is excreted both in faeces (about 40%) and in urine. The most frequent adverse effects of DFO are local reactions at the site of infusion, such as pain, swelling, induration, erythema, burning, pruritus, wheals and rash, occasionally accompanied by fever, chills and malaise.

### 7.1 Iron overload-related complications

Iron overload of tissue with or without transfusion is fatal, which is the most important complication of  $\beta$ -thalassemia if not prevented or adequately treated, which is a major focus of management (Olivieri & Brittenham, 1997). In patients who are not receiving transfusions, abnormally regulated iron absorption results in increases in body iron burden, depending on the severity of erythroid expansion (Pippard et al., 1979, Pootrakul et al., 1988). Regular transfusions may double this rate of iron accumulation. Most clinical manifestations of iron loading do not appear until the second decade of life in patients with inadequate chelation. After approximately one year of transfusions, iron begins to be deposited in parenchymal tissues, (Risdon et al., 1973) where it may cause substantial toxicity as compared with that within reticuloendothelial cells (Hershko & Weatherall 1988, Hershko et al., 1998). As iron loading progresses, the capacity of serum transferrin, the main transport protein of iron, to bind and detoxify iron may be exceeded and a non-transferrin-bound fraction of plasma iron may promote the generation of free hydroxyl radicals, propagators of oxygen-related damage (Hershko & Weatherall 1988, Hershko et al., 1998). The advances in free-radical chemistry have clarified the toxic properties of these and other oxygen-derived species generated by iron, which may cause widespread tissue damage (Hershko et al., 1998). Although the body maintains a number of antioxidant mechanisms against damage induced by free radicals, including superoxide dismutases, catalase, and glutathione peroxidase, in patients with large iron burdens these may not prevent oxidative damage (Hershko & Weatherall 1988, Hershko et al., 1998). In the absence of chelating therapy the accumulation of iron results in progressive dysfunction of the heart, liver, and endocrine glands (Olivieri & Brittenham 1997). Extensive iron deposits are associated with cardiac hypertrophy and dilatation, degeneration of myocardial fibers, and in rare cases fibrosis (Buja & Roberts 1971). In patients who are receiving transfusions but not chelating therapy, symptomatic cardiac disease has been reported within 10 years after the start of transfusion (Wolfe et al., 1985) and may be aggravated by myocarditis (Kremastinos et al., 1995) and pulmonary hypertension (Aessopos et al., 1995, Duet et al., 1997). Iron-induced liver disease is a common cause of death in older patients (Zurlo et al., 1989) and is often aggravated by infection with hepatitis C virus. Within two years after the start of

transfusions, collagen formation (Iancu et al., 1977) and portal fibrosis (Thakerngpol et al., 1996) have been reported; in the absence of chelating therapy, cirrhosis may develop in the first decade of life (Risdon et al., 1973, Witzleben & Wyatt 1961, Jean et al., 1984). The striking increases in survival in patients with  $\beta$ -thalassemia over the past decade have focused attention on abnormal endocrine function (delayed puberty, hypogonadism and assisted reproduction), now the most prevalent iron-induced complication in older patients. Iron loading within the anterior pituitary is the primary cause of disturbed sexual maturation, reported in 50 percent of both boys and girls with the condition (Italian Working Group on Endocrine Complications, 1995) and also cause growth deficiency, which therapeutic use of GH to thalassemia patients proven to have GH deficiency, who may have a satisfactory response to treatment (Karydis et al., 2004, Wu et al., 2003). Furthermore, early secondary amenorrhea occurs in approximately one quarter of female patients over the age of 15 years (Italian Working Group on Endocrine Complications, 1995).

Even in the modern era of iron-chelating therapy, diabetes mellitus is observed in about 5 percent of adults (Italian Working Group on Endocrine Complications, 1995). As the iron burden increases and iron-related liver dysfunction progresses, hyperinsulinemia occurs as a result of reduced extraction of insulin by the liver, leading to exhaustion of beta cells and reduced circulating insulin concentrations (cause diabetes and impaired glucose tolerance) (Cavallo-Perin et al., 1995). Studie reporting reduced serum concentrations of trypsin and lipase (Gullo et al., 1993) suggest that the exocrine pancreas is also damaged by iron loading. Over the long term, iron deposition also damages the thyroid (hypothyroidism), parathyroid (hypoparathyroidism), and adrenal glands (Magro et al., 1990, Sklar et al., 1987) and may provoke pulmonary hypertension, right ventricular dilatation, and restrictive lung disease (Du et al., 1997, Factor et al., 1994, Tai et al., 1996).

In most studies, bone density is markedly reduced (cause osteoporosis) in patients with  $\beta$ -thalassemia, particularly those with hypogonadism. Osteopenia may be related to marrow expansion, even in patients who receive transfusions, (Pootrakul et al., 1988) or to iron-induced osteoblast dysfunction, diabetes, hypoparathyroidism, or hypogonadism (Anapliotou et al., 1995).

## 7.2 Splenectomy

If the annual red cell requirement exceeds 180-200 ml/Kg of RBC (assuming that the Hct of the unit of red cells is about 75%), splenectomy should be considered, provided that other reasons for increased consumption, such as hemolytic reactions, have been excluded. Other indications for splenectomy are symptoms of splenic enlargement, leukopenia and/or thrombocytopenia and increasing iron overload despite good chelation (Weatherall & Clegg 2001).

## 8. Bone marrow and cord blood transplantation

Successful allogeneic bone marrow transplant for severe  $\beta$ -thalassemia was first reported in 1982 (Thomas et al., 1982). Since that time, numerous transplants have been performed with the best outcome for well chelated patients with no liver disease (Lucarelli et al., 1990). Bone marrow transplantation (BMT) from HLA-identical donors has been successfully performed worldwide. BMT remains the only definitive cure currently available for patients with thalassemia. The outcome of BMT is related to the pretransplantation clinical conditions, specifically the presence of hepatomegaly, extent of liver fibrosis, history of regular chelation and hence severity of iron accumulation. In patients without the above risk factors,

stem cell transplantation from an HLA identical sibling has a disease free survival rate over 90% (Gaziev & Lucarelli, 2003). The major limitation of allogenic BMT is the lack of an HLA-identical sibling donor for the majority of affected patients. In fact, approximately 25-30% of thalassemic patients could have a matched sibling donor. BMT from unrelated donors has been carried out on a limited number of individuals with  $\beta$ -thalassemia. Provided that selection of the donor is based on stringent criteria of HLA compatibility and that individuals have limited iron overload, results are comparable to those obtained when the donor is a compatible sib (La Nasa et al., 2005). However, because of the limited number of individuals enrolled, further studies are needed to confirm these preliminary findings. If BMT is successful, iron overload may be reduced by repeated phlebotomy, thus eliminating the need for iron chelation. Complications include a rate of Chronic graft versus-host disease (GVHD) of variable severity may occur in 2-8% of individuals and a variable incidence of mixed chimerism (Angelucci et al., 1997). Post-transplantation management of preexisting hepatic iron overload, iron-induced cardiac dysfunction, and viral hepatitis may prevent progression of these processes (Angelucci et al., 1997). Cord-blood transplantation, the use of unrelated phenotypically matched donors, and in utero transplantation (Westgren et al., 1996), offers a good probability of a successful cure and is associated with a low risk of GVHD (Locatelli et al., 2003, Pinto & Roberts, 2008). By this mean, for couples who have already had a child with thalassemia and who undertake prenatal diagnosis in a subsequent pregnancy, prenatal identification of HLA compatibility between the affected child and an unaffected fetus allows collection of placental blood at delivery and the option of cord blood transplantation to cure the affected child (Orofino et al., 2003). On the other hand, in cases with an affected fetus and a previous normal child, the couple may decide to continue the pregnancy and pursue BMT later, using the normal child as the donor. At present this therapy is of limited applicability because only a small number of patients have a related, human leukocyte antigen matched donor. Improvements in transplantation from unrelated donors may expand the use of this treatment in the future.

## 9. Genetic counseling and prenatal diagnosis

Prevention of  $\beta$ -thalassemia is based on carrier identification, genetic counseling and prenatal diagnosis (Cao et al., 1998). Carrier detection has been previously described. Genetic counseling provides information for individuals and at risk couples (i.e. both carriers) regarding the mode of inheritance, the genetic risk of having affected children and the natural history of the disease including the available treatment and therapies under investigation. Prenatal diagnosis for pregnancies at increased risk is possible by analysis of DNA extracted from fetal cells obtained by amniocentesis, usually performed at approximately 15-18 weeks gestation or chorionic villi sampling (CVS) at 10-11 weeks gestation. Both disease-causing alleles must be identified before prenatal testing can be performed. Analysis of fetal cells in maternal blood and analysis of fetal DNA in maternal plasma for the presence of the father's mutation are currently under investigation (Mavrou et al., 2007, Lo 2005). Pre-implantation genetic diagnosis may be available for families in which the disease-causing mutations have been identified.

## 10. Screening and diagnosis for hemoglobin variants and thalassemia

There are many techniques that have been used to screen and diagnose for hemoglobin variants and thalassemia, mostly done in combinations. These techniques were ranging

from screening to extensive analysis, including a few indirect studies. Screening techniques can indicate a defect in hemoglobin synthesis. Positive results from these tests need confirmation by a more extensive analysis technique. Negative results normally help in cutting down the number of subjects that need to be further diagnosed by a more advanced and complicated testing. Extensive analysis techniques can give more precise information in types of thalassemia or types of Hb variants. They normally perform with higher instruments and technologies, and therefore are more expensive than screening techniques. The flow chart shown in Fig 4 summarizes the techniques for diagnosis of thalassemia and hemoglobinopathies that are commonly used in most laboratories.

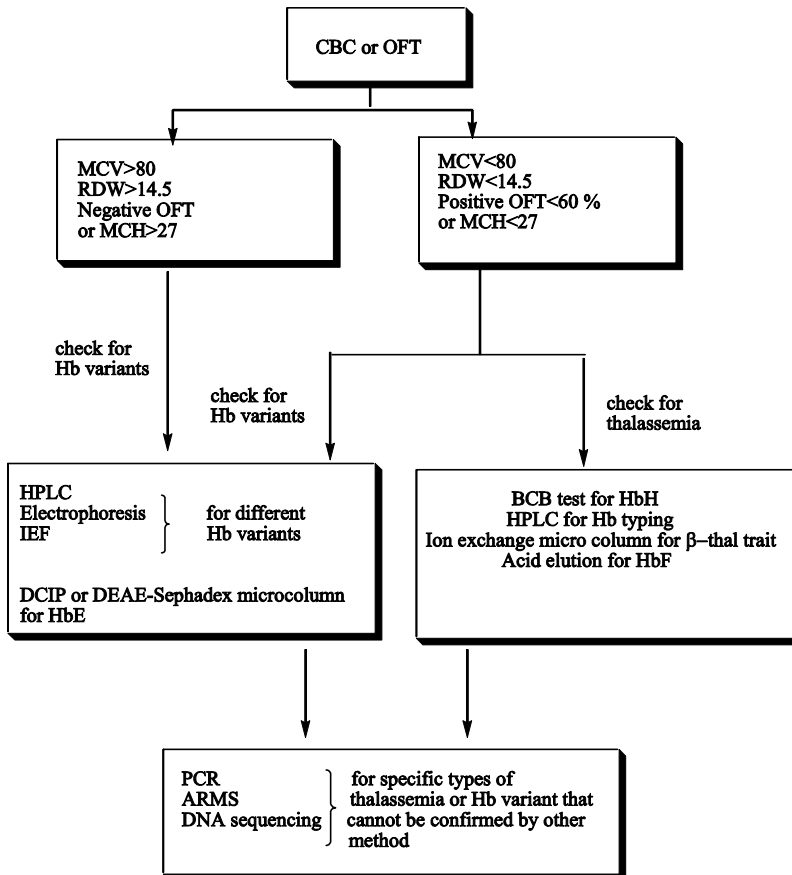

Fig. 4. The summarised chart of normal process of hemoglobin variants and thalassemia

### 10.1 Screening techniques for thalassemia

Screening techniques are defined as simple techniques and low cost which can indicate the possibility of having thalassemia. These techniques should involve the least sample pretreatment and be rapid, and may not need special instrumentation. These techniques could be used in any primary health care setting. This would lead to low cost and high sample

throughput analysis. Positive samples need further confirmatory test while negative samples can be eliminated from further complicated and expensive testing. These screening techniques cannot provide the information on the exact type of hemoglobinopathies, but can help in cutting down the number of samples from unnecessary complicated and expensive testing.

### 10.1.1 Complete blood count (CBC)

Complete blood count, a primary screening for thalassemia used an electronic blood-cell counter to provide accurate erythrocyte indices as the characteristics of the blood (Hillman & Ault, 1980). The main features of the blood tested in the CBC are the total white blood cell count (WBC), red blood cell count (RBC), hematocrit (Hct), hemoglobin (Hb), red cell distribution width (RDW), peripheral blood smear and other important erythrocyte indices (EI), included mean corpuscular volume (MCV), mean corpuscular hemoglobin (MCH), and mean corpuscular hemoglobin concentration (MCHC) (Klee et al., 2000). Among these parameters, MCV and MCH are the most important indices that can indicate the existence of thalassemia trait, i.e., when individuals who have hypochromic microcytosis with MCV < 80 fL and MCH < 27 pg should be investigated further.

Parameter	Normal range
RBCs ( $\times 10^{12}/L$ )	3.8 - 5.8
Hb (g/dL)	11.5 - 16.5
Hct (%)	37.0 - 47.0
MCV (fL)	76 - 96
MCH (pg)	27 - 32
MCHC (g/dL)	30.0 - 35.0
RDW (%)	11.5 - 14.5

Table 2. The normal ranges of each parameter

In table 2 summarizes the tests performed in the CBC, the calculation needed for each parameters and the approximate normal cutoff level. However, due to the similar lowed blood cell count between the patients with thalassemia and the ones with iron deficiency, it has been suggested that in the geographic regions where iron deficiency rate is high, the cutoffs for thalassemia interpretation should be adjusted to more suitable values by using a receiver operator characteristic (ROC) curve (Kotwal et al., 1999), which in this case should better differentiate thalassemic microcytosis from non-thalassemic ones (i.e., iron deficiency patients). As the study in Thailand, they used the combination of MCH (25) pg, RDW (14.5%) and OFT (<55%) with the lower cutoff to increase the screening specificity in those area (Tangvarasittichai et al., 2004). Many laboratories use a CBC autoanalyzer which can provide many blood parameters (such as MCH, MCV, RDW) also be added along with osmotic fragility test an alternative screening test for specific thalassemia testing.

### Combined red blood cells indices for $\alpha$ -Thalassemia-1 Screening

1. Red blood cells (RBC) indices included hemoglobin (Hb), hematocrit (Hct), mean corpuscular volume (MCV), mean corpuscular hemoglobin (MCH), MCHC, and RDW from the automated blood cell analyzer
2. In the study of Tangvarasittichai et al. (2004) used the ROC curve and the AUC of each parameters showed the % specificity of each parameter and their combination for screening the  $\alpha$ -thalassemia-1 elute as in the table below.

Parameters (Cut-off point)	% Specificity
MCH/OFT/RDW (25 pg/55%/14.5%)	92.4
MCH/OFT/MCV (25 pg/55%/75 fL)	91.9
MCH/OFT (25 pg/55%)	91.7
MCH/RDW/MCV (25 pg/14.5%/75 fL)	90.0
MCH/RDW (25 pg/14.5%)	89.6
MCH/MCV (25 pg/75 fL)	88.5

Table 3. The combined red blood cells indices to increase the specificity for screening  $\alpha$ -thalassemia 1

### 10.1.2 Osmotic fragility test (OFT)

The main purpose of this technique is used as a diagnostic test for the hereditary spherocytosis and it is also useful for screening of thalassemia. This simple technique utilizes osmosis, the movement of water from lower to higher salt concentration region, to test for the osmotic resistance of the red blood cell (Fernandez-Alberti et al., 2000). A single hypotonic saline solution can be prepared from dilution of a Tyrode's solution, which is composed of NaCl, KCl,  $\text{CaCl}_2 \cdot 6\text{H}_2\text{O}$ ,  $\text{MgCl}_2 \cdot 6\text{H}_2\text{O}$ ,  $\text{NaHCO}_3$ ,  $\text{NaH}_2\text{PO}_4$ , glucose and distilled water (Electron Microscope Sciences Catalog, Available: <http://www.emsdiasum.com/ems/chemicals/salt.html> (October 16, 2003). Different laboratories may be using slightly different recipes for preparation of hypotonic salt solution, but all are normally based on the same concept of kinetic osmotic fragility. The most simple of a single hypotonic saline solution can be prepared which is composed of 0.45% glycerine and 0.36% sodium chlorine in phosphate buffer (pH7.4) (Sirichotiyakul et al., 2004). Whole blood is thoroughly mixed with this solution. In a hypotonic condition, the concentration of salt on the outside of a cell is lower than that on the inside, resulting in net water movement into cells. Normal red blood cells are broken within 1–2 min and the mixture then turns clear and reddish. Abnormal red blood cells have deviated osmotic resistances as compared to normal red cells. Spherocytes and erythrocytes with various membrane defects may show decreased osmotic resistance. However, red blood cells of thalassemia have higher osmotic resistance and thus have slower rupture rate, therefore the mixture remains turbid even after 1–2 h (Silvestroni & Bianco 1983). The OFT is a quick preliminary and very economic test before performing further studies of the blood cells.

The percent hemolysis of more than 60% was considered normal (no  $\alpha$ -thalassmia-1 or  $\beta$ -thalassemia trait). The screening test (OFT) was considered abnormal or positive test when the percent hemolysis is of 60% or less [ $\beta$ -thalassemia trait=  $30.5 \pm 1.4\%$ ;  $\alpha$ -thalassmia 1 =  $30.8 \pm 1.2\%$ ] and the positive test of gold standard or final diagnosis was considered either when HbA2 levels of 4.1–9% or positive PCR (SEA type).

### 10.2 Conventional confirmatory tests for thalassemia and Hb variants

These are useful tests to confirm the existence of certain Hb variants or abnormal level of some Hb types. Confirmatory tests for Hb variants include deoxyhemoglobin solubility test (DST) for detection of HbS and dichlorophenol indophenol precipitation test (DCIP) for detection of HbE. HbH disease which relates to  $\alpha$ -thalassemia can be detected by DCIP and brilliant cresyl blue test (BCB). Alkaline resistant hemoglobin test (ART) and acid elution stain (AES) are used for detection of abnormal levels of HbF, which can help identify some types of thalassemia. The ion exchange microcolumn technique is used to quantify the amount of HbA2 and HbF to identify  $\beta$ -thal trait, E-trait and EE homozygotes. These conventional techniques are relatively low cost and do not require complicated instrumentation. However,

some of these techniques may need a highly experienced operator to translate the results. Therefore, availability of more modern instrumentation that can provide more precise information with little requirement of an experienced operator and less usage of toxic chemicals diminishes the use of some of these conventional techniques such as DST and ART.

### 10.2.1 Deoxyhemoglobin solubility test

Deoxyhemoglobin solubility test for HbS based on its insolubility in a potassium phosphate saponin buffer solution (composed of  $K_2HPO_4$ ,  $KH_2PO_4$ , saponin and distilled water). Turbidity would be observed within 5 min if the whole blood containing HbS were mixed with sodium hyposulfite and saponin buffer. This test can discriminate samples with HbS from samples with almost all other hemoglobins except Hb Bart's and some rare sickle Hb, if a positive test result is shown (i.e., high enough turbidity that newsprint cannot be seen through the test mixture when placed behind the tube), then a follow-up test by electrophoresis is recommended. A false-negative result may be from a high anemic condition (Fairbanks, 1980, Nalbandian et al., 1971, Greenberg et al., 1972).

### 10.2.2 Hemoglobin precipitation test

Some hemoglobin variants such as HbH ( $\beta_4$  with  $\alpha$ -thalassemia) and Hb Koln ( $\beta^{98Val \rightarrow Met}$ ) are classified as unstable hemoglobins which can be precipitated by heating or adding a chemical such as isopropanol or dichlorophenol indophenol (Dispenzieri, 2001, Winichagoon et al., 2002).

#### 10.2.2.1 The heat instability test

Test can be carried out at either medium temperature ( $50^\circ C$ ) for 1–2 h or at high temperature ( $68^\circ C$ ) with chemical reaction aids for 1 min. Although taking longer time, the medium temperature stability test is very simple. The clear supernatant of erythrocyte hemolysate in Tris buffer medium, obtained after removing plasma, hemolyzing with distilled water and removing stroma, is placed in the  $50^\circ C$  water bath for 1 h. Normal hemolysates remain completely clear, while unstable hemoglobins cause flocculation of various turbidities. The test can be done much faster by using chemicals, i.e., KCN and  $K_3Fe(CN)_6$  to form hemolysate cyanmethemoglobin. In a phosphate buffer medium, this hemolysate cyanmethemoglobin is agitated rapidly in the  $68^\circ C$  hot water bath. After 1 min, normal hemolysate may show slight cloudiness and therefore this high temperature method, even though very fast, may need high experience in interpretation in order to avoid a false-positive interpretation (Klee, 1980, Dacie et al., 1964).

#### Hemolysate preparation (For heat, isopropanol precipitation)

**Reagent:** (i) 0.9% NaCl, (ii) Transformation solution (TS): consist with 0.2 g  $K_3Fe(CN)_6$  and 0.2 g KCN in 1000 ml distill water (DW) (iii) Carbon tetrachloride ( $CCl_4$ ) solution

**Sample:** EDTA whole blood. **Reagent:** 0.15 M Tris-HCl buffer.

Type	%Hb instability
Normal	2.3±1.2
HbH	9.7±2.4
$\alpha$ -Thalassemia trait	4.3±1.7
Homozygous $\beta$ -thalassemia	5.4±1.6
$\beta$ -Thalassemia trait	4.3±2.3
$\beta$ -Thalassemia/HbE	6.4±2.2

Table 4. % Hb instability value by Heat Precipitation

### 10.2.2.2 Isopropanol precipitation test

Another way to demonstrate the Hb instability is with isopropanol precipitation. Packed erythrocytes, cold deionized water and  $\text{CCl}_4$  (1:1:1.5 ratio) are placed in a closed tube and vortexed for a few minutes, followed by centrifugation. The clear supernatant is then mixed with isopropanol-Tris buffer at a control temperature of about 37 °C. Unstable hemoglobins cause more turbidity over time, while normal hemoglobins remain clear for at least 30 min. The isopropanol test is reported to have some limitations on the subjects that contain  $\geq 5\%$  HbF, and those that are inappropriately preserved (i.e., unrefrigerated or too old samples) may give false positive results. Adding anticoagulating reagent can help reduce the false reading but it is suggested that the samples with high HbF should be tested by heat stability, as it is not interfered by HbF (Klee, 1980, Brosious et al., 1976, Carrell & Kay, 1972).

**Reagent:** 0.1 M Tris-HCl buffer pH 7.4; Isopropanol buffer: as a mixture of 17 ml isopropanol with 83 ml of Tris-HCl buffer

Type	%Hb instability
Normal	1.2±1.1
HbH	16.1±5.2
$\alpha$ -Thalassemia trait	3.5±1.9
Homozygous $\beta$ -thalassemia	4.2±3.0
$\beta$ -Thalassemia trait	3.2±2.1
$\beta$ -Thalassemia/HbE trait	2.9±1.7

Table 5. % Hb instability value by Isopropanol Precipitation

### 10.2.2.3 Dichlorophenol indophenol (DCIP) precipitation test

The dichlorophenol indophenol (DCIP) precipitation test is also used widely to screen for HbE and HbH. DCIP can oxidize HbE and HbH faster than any other type of hemoglobin, and therefore it can be used to screen for HbE and HbH. Interpretation of results can be difficult since it involves observing the cloudiness in a deep blue color of DPIC solution. However, a reducing agent may be added to overcome this problem. For example, in the AOAC standard titration method for ascorbic acid, the color of an oxidant DCIP is changed from dark blue to light blue on the way to the end point pink (Helrich, 1995). Therefore, if a small amount of ascorbic acid were added to the DCIP thalassemia test, then the observation could be made more accurately under the light blue condition.

**Reagents:** DCIP reagent: Tris base 4.36 g, EDTA  $\text{Na}_2 \cdot 2\text{H}_2\text{O}$  2.68 g, DCIP (Sigma) 0.0276 g, Saponin 0.05 g dissolve in DW adjusted pH 7.5 by 6M HCl, then DW to 500 ml store at 4°C.

**Interpretation results:** Negative = Clear; Positive = cloudiness in a deep blue color of DCIP solution. Hemoglobin precipitation tests can be used to screen for some hemoglobin variants but they may not be able to speciate the types of hemoglobins (i.e., HbE and HbH show similar results). Further tests are needed to pinpoint the exact type.

### 10.2.3 Brilliant cresyl blue test or new methylene blue test

Both simple colorimetric tests are based on the same procedures with different reagents, specifically performed for HbH diagnosis. HbH is unstable and it precipitates in the red cells, giving the appearance of many small golf balls inside the cells that can be observed when staining the blood film with brilliant cresyl blue ( $\text{C}_{17}\text{H}_{12}\text{OClN}_3\text{O}$ ) or new methylene blue ( $\text{C}_{18}\text{H}_{12}\text{ClN}_3\text{S} \cdot \text{SClZnCl}_2$ ) (Brilliant cresyl blue MSDS sheet, Available: <http://www.proscitech.com/catalogue/msds/c085.pdf> (April 14, 2003), New Methylene,



Blue MSDS Sheet. Available: <http://www.jtbaker.com/msds/englishhtml/n2700.htm> (April 20, 2003)). The incubation time of blood and the reagents (brilliant cresyl blue in sodium citrate media) takes about 1 h in a controlled temperature setting of about 37 °C (Rigas et al., 1961). This test is very useful to confirm for  $\alpha$ -thalassemia involving HbH inclusion body. However, the technique yields low sensitivity for  $\alpha$ -thal trait and therefore it should only be used as a confirmatory test, but not for screening of  $\alpha$ -thalassemia.

#### 10.2.4 Alkaline resistant hemoglobin test

This is a test for abnormal level of fetal hemoglobin (HbF). Normally hemoglobins are denatured at alkaline pH such as in NaOH solution and they can be precipitated readily with saturated ammonium sulfate ((NH<sub>4</sub>)<sub>2</sub>SO<sub>4</sub>) solution. However, HbF is not denatured as easily and remains soluble. Differences in alkaline resistance of the normal Hb and fetal Hb allow for rapid testing for the amount of HbF in blood. The procedure consists of a few experimental and calculation steps (Klee, 1980, Singer et al., 1951, Betke et al., 1959). A suspended mixture of Hb-cyanide-ferricyanide (or cyanmethemoglobin) is prepared by adding packed red cells, obtained from centrifugation of whole blood in isotonic saline solution, into a cyanide-ferricyanide solution (KCN and K<sub>3</sub>Fe(CN)<sub>6</sub> in distilled water). Then NaOH is added and the solution is mixed for a few minutes before adding the saturated (NH<sub>4</sub>)<sub>2</sub>SO<sub>4</sub> solution. Coagulated protein can be removed by filtering the mixture until a clear filtrate is obtained. The percent of alkaline resistant hemoglobin is calculated based on the absorbance of the filtrate (Df) and the absorbance of the 1:10 dilution of the original cyanmethemoglobin without NaOH and (NH<sub>4</sub>)<sub>2</sub>SO<sub>4</sub> added (Db) at 540 nm, using the following equation: (100 Df)/(10 Db).

In a normal person more than 1 year old, the percentage of HbF should be expressed as being less than 1–2% by using this method. Higher levels of HbF will be suspected of having a hemoglobin disorder of some kind. Although the method was found to mistakenly yield lower results for a subject with HbF higher than 30% of total hemoglobin, such as in umbilical cord blood of newborns, this method was sufficiently sensitive and reproducible for measuring 1–10% HbF, providing that final cyanmethemoglobin concentration is higher than 480 mg/100 ml (Pembrey et al., 1972). In the cases where high amount of HbF is present, an alternative method such as immunological determination of HbF, e.g., by the gel precipitation or immuno-diffusion, involving the use of monoclonal antibody against HbF, may be used (Weatherall & Clegg, 2001, Yuregir 1976, Dover et al., 1979).

**Reagent:** (i) TS as 0.2 g K<sub>3</sub>(FeCN)<sub>6</sub> and 0.2 g KCN in 100 ml DW (ii) 1.2 N NaOH (iii) saturated (sat) (NH<sub>4</sub>)<sub>2</sub>SO<sub>4</sub>

Type	%HbF
Normal	<1
$\beta$ -Thalassemia trait	1- 10 %
$\beta$ -Thalassemia major	>50%

Table 6.

#### 10.2.5 Acid elution stain (modified Kleihauer–Betke test)

This is a simple test for HbF and Hb Bart's. After smearing a blood sample on the slide and letting it dry, the slide is immersed in an 80% alcohol solution (ethyl, methyl or propyl alcohol) for 2–3 min. After that, the slide is immersed in a staining solution of Amido Black 10B (C<sub>22</sub>H<sub>14</sub>N<sub>6</sub>O<sub>9</sub>S<sub>2</sub>Na<sub>2</sub>) prepared in alcohol with pH adjusted to 2.0. After 3 min, the slide is

washed under running water for 1 min. In the acidic condition, HbA, HbA<sub>2</sub>, HbE, and HbH will be eluted out of the blood cells, leaving the cells empty (ghost cells) and showing no color. HbF and Hb Bart's can tolerate acid and are stained by the Amido Black 10B, showing dark blue color of the cells which can be observed under the microscope. There are a few precautions that need to be taken when working with this technique. If the slide is left dry for too long, HbA will not be eluted out. The concentration of alcohol is also important because alcohol higher than 85% will cause HbA to stay in the cell, while lower than 65% will cause vacuolization of HbF. In addition, if the pH of the solution is higher than 2.5, HbA will not be eluted. All these cases will show false results (Research Organics. Available: <http://www.resorg.com/>(October 17, 2003), Betke & Sanguanserm Sri, 1972). The drawbacks of this technique are time consuming and subjected to human error. Another possible way of detection of HbF is flow cytometry which is more precise as described later.

### 10.2.6 Ion exchange micro-column

In the regions where economic restriction does not allow for the use of a relatively higher cost instrument such as HPLC, a cheaper method such as this ion exchange microcolumn along with other inexpensive tests can be used in combination to diagnose the type of thalassemia. This technique is based on ion exchange chromatography as a simplified version of high performance liquid chromatography. The use of diethylaminoethyl DEAE anion exchanger, packed in a relatively cheap and small syringe, and Tris-HCl mobile phase can be adapted to separate HbA<sub>2</sub> and HbF effectively. The relative amounts of these Hbs can be estimated by calculating the peak areas of the absorbance, measured at 415 nm, of fractions eluted from the column. It has been shown that the results obtained from the batchwise micro-column are in agreement with those from HPLC, though the method lacks automation and yields lower precision (Dozy et al., 1968, Brosious et al., 1978, Srisawang et al., 2003). However, the result from ion exchange micro-column technique is acceptably accurate and precise and can be used to confirm some types of thalassemias such as  $\beta$ -thalassemia trait. In addition, with its simplicity and low cost, some laboratories perform this technique together with the OF tests as regular screening techniques, especially where thalassemia cases related to abnormal ratio of HbA<sub>2</sub> and HbF is commonly found such as in Thailand. It has been estimated that the cost for chemicals and materials per test of the micro-column technique is approximately five times less than that of HPLC. Even though the total analysis time per run is longer than automated HPLC (4 h versus 20 min), many ion exchange micro-columns can be set up and run at the same time. Therefore, the total analysis time of, e.g., 50 tests using multiple micro-columns at one time is less than performing 50 continuous HPLC runs (16 h using HPLC and 4 h using ion exchange micro-columns). In addition, an attempt to reduce the analysis time per run and to make the micro-column technique more automated has been carried out. A flow injection analysis system was joined together with a much smaller ion exchange column to improve the analysis time for hemoglobin typing as compared to the batch process (Srisawang et al., 2003). More work needs to be done, but the preliminary results have suggested that the flow based and reduced volume ion exchange column system has the potential to improve the analysis time per run and to greatly reduce the amount of blood sample needed for the analysis.

**Hemoglobin E detection: DEAE Sepharose Microcolumn** (GE Healthcare BioSciences, Uppsala, Sweden)

Sufficient DEAE Sepharose was added to columns of 10x1.5 cm to produce a 2 cm Sepharose layer (Figure 5), was saturated with buffer A (0.05 M Tris, pH 8.5). Hemolysate was loaded

in the column (40 $\mu$ l of EDTA blood sample to 10 ml 0.05 M, pH 8.0 Tris buffer B. Hb E, which is a weak anion, eluted first from the microcolumn by using buffer B as the elution buffer. The Hb E positive blood samples produced an orange eluted. Hb E negative sample produced a colorless. This Hb E microcolumn testing was approximately 10-15 minutes.



Fig. 5. DEAE Sepharose Microcolumn after preparation for hemoglobin E detection

### 10.3 Instrumental techniques for determination of thalassemia and Hb variants

These techniques involve modern technologies of complicated instrumentation. They can be automated and are usually faster and more reliable but more expensive than the conventional techniques. Even though these techniques can provide detailed information and can help in diagnosis of many types of Hb variants, there are a few exceptional Hb variant cases that cannot be identified with these techniques, and more extensive confirmatory tests are needed. Most instrumental techniques can perform qualitative and quantitative analysis, but with limited ways to accurately quantitate the signals, such as in gel electrophoresis, these techniques have been used mainly for diagnosis of Hb variants rather than for detection of abnormal level of Hbs in thalassemia diagnosis, as shown in the flow chart in Fig. 4.

#### 10.3.1 High performance liquid chromatography

High-performance liquid chromatographic (HPLC) methods with high sensitivity and specificity have been developed for both screening and confirmation of hemoglobinopathies and thalassemia in newborns. The HPLC technique requires a very small amount of blood samples ( $\mu$ l), therefore, it is very suitable for prenatal diagnosis of thalassemia (Maiavacca et al., 1992, Sanguanserm Sri et al., 2001, Rao et al., 1997), where sample may be limited and difficult to obtain. In HPLC, particle size of the stationary phase packed in the column is quite small (about 2-5 $\mu$ m). The degree of interactions determines the degree of migration and separation of the components (Skoog & Leary, 1992, Christian, 2004). However, in most laboratories, HPLC has been used for diagnosis of Hb variants rather than for quantification of normal Hb or thalassemia diagnosis. There are many reports showing the agreement of results obtained from HPLC and those obtained from other techniques such as the globin synthesis technique, isoelectrofocusing, carboxymethylcellulose chromatography and DNA sequencing (Sanguanserm Sri et al., 2001, Rao et al, 1997, Fucharoen et al., 1998).

Cation exchangers, such as CM-cellulose (CMC) and silica supported with carboxylic acid residues with bis-Tris-KCN developer, can also be used for the same purpose (Rouyer-Fessard et al, 1989, Papadea & Cate, 1996, Wilson et al., 1983). The ratio of different globin chains (e.g.,  $\beta:\gamma$  for  $\beta$ -thalassemia diagnosis) can also be determined with HPLC using a reverse phase C18 column and shows similar results to those obtained from CMC which is normally employed for this purpose (Congote, 1981). HPLC has become the preferred method for thalassemia screening because of its speed and reliability. An automated HPLC system has been developed primarily detection of  $\beta$ -thalassemia carriers, HbS, and HbC. In the study of Fucharoen et al. (1998), they used automatic HPLC system (VARIANT™, Bio-Rad) set up with the  $\alpha$ -thalassemia short (ATS) program and  $\beta$ -thalassemia shot (BTS) program to detect various types of thalassemias in both prenatal and postnatal specimens. HPLC has an overall performance better than electrophoresis.

Analyses were performed with a HPLC machine interfaced with a computer program, with an autoinjector or manual injector, and a UV detector at 415 nm. A 3.5 x 0.46 cm cation exchanger column packed with porous (100-nm pore size) 5-gm microparticulate polyaspartic acid-silica (Poly CAT Atm) or Poly LC (Columbia, MD).

Sample preparation by using 100  $\mu$ l of EDTA whole blood was washed with isotonic saline (NaCl 9 g/L). The cells were then lysed by adding two to three volumes of water, vortex-mixed, and centrifuged at 3000 x g for 5 min. Added 50  $\mu$ l of hemolysate to 1 mL of mobile phase A, of which 20  $\mu$ l was injected onto the column. The column effluent was monitored at 415 nm and the peak areas were used for the individual quantitative hemoglobin peaks.

The gradient program was made up of a mobile phase A (10 mmol/L Bis-Tris, 1 mmol/L KCN, pH 6.87) and mobile phase B (10 mmol/L Bis-Tris, 1 mmol/L KCN, 200 mmol/L NaCl, pH 6.57). With a flow rate of 1.5 ml/min (a new column should be rinsed with water for 10 min and with mobile phase B for at least 20 min, and should then be equilibrated with 12% B for another 20 min before sample application). Elution of hemoglobins was performed by increasing the mobile phase B to 40% and to 100% at 8 and 12 min, respectively, and then decreasing to 12% at 13 min. The column was re-equilibrated with 12% mobile phase B for at least 7 min before application of next sample.

Anion exchange resin DEAE and gradient Tris-HCl buffer solution, pH 8.5–6.0, is a widely used stationary–mobile phase system for HbA<sub>2</sub> and HbF quantification to effectively diagnose  $\beta$ -thalassemia and Hb Bart's hydrop fatalis that occur frequently in Southeast Asia (Sanguanserm Sri et al., 2001, Sanguanserm Sri et al., 2001). The system can also separate other Hb variants such as HbS, HbC and HbJ (Huisman & Dozy, 1962, Huisman & Dozy, 1965). In the study of Tangvarasittichai et al. (2009), they modified the fast protein liquid chromatography (FPLC) method from microcolumn chromatographic techniques for HbA<sub>2</sub> determination. The FPLC, a general system was used for protein purification and separation. However, they used the method for FPLC application for separation HbA<sub>2</sub>, as the diagnosis of  $\beta$ -thalassemia (Tangvarasittichai et al., 2009).

### **10.3.2 Fast protein liquid chromatography (FPLC) technique for the diagnosis of $\beta$ -Thalassemia (as demonstrated by Tangvarasittichai et al. (2009))**

Hemolysate was prepared by mixing 50  $\mu$ l of EDTA blood sample with 10.0 ml of Tris buffer A. 0.5 ml of hemolysate was passed through a 5 x 0.5 cm (1ml) column of diethylaminoethyl (DEAE) sepharose, Hi Trap™ (GE Healthcare, Sweden) connected to the FPLC (AKTA prime, Amersham Biosciences, USA) with flow rate 2 ml/min. Effluent from column was monitored by a single path ultraviolet monitor at 280 nm in a 10 min path-

length high resolution flow cell, and the histogram was saved in the computer. The reagents for FPLC were as linear gradient of buffer A [50 ml of stock Tris buffer (as Tris 60.57 g mixed with 500 ml distilled water, adjusted pH 9.0 with 4 M HCl) was diluted in distilled water 1,000 ml, added 0.1 g KCN (adjusted pH 8.1 with 4 M HCl)], and buffer B (diluted 500 ml of buffer A with 500 ml 1M NaCl). The gradient profile to achieve the separation as in the table

Linear gradient profile of buffer A and B	
Buffer A, volume (ml)	Buffer b, %
10.0	0
11.0	10
12.0	30
13.0	50
14.0	70
15.0	90
15.5	100
20.0	0

Table 7. The gradient profile of FPLC technique

The fractions were then separated to HbA<sub>2</sub> or HbE (in the same fraction, HaA<sub>2</sub>/E), HbA and HbF

**The cut-off values of FPLC for HbA<sub>2</sub>/E diagnosis** were as follows: Normal (<6%),  $\beta$ -thalassemia (7-10%), He-trait (>10-40%), homozygous HbE (>60%), and  $\beta$ -thalassemia/He (40-60%)

### 10.3.3 Electrophoresis

Electrophoresis is one of the widely used techniques for analyzing hemoglobin variants based on the movement of different Hb or different globin chains, containing different charges, in the electric field. At an alkaline pH, Hb is negatively charged and will move toward the anode (positively charged) terminal. Electrophoresis of total Hb is different from electrophoresis of separated globin chains. Electrophoresis of hemolysates on cellulose acetate membrane is mainly used in alkaline pH electrophoresis, is a simple, reliable method for detecting abnormal hemoglobin, and capable of separating common hemoglobin variants such as S, f, a, and C. Normal operating voltage is about 250mV and the approximate run time is about 90 min. After that, the membrane needs to be stained, de-stained and air dried before separation of globin chains can be observed. The main limitation of electrophoresis at alkaline pH is a inability to differentiate HbA<sub>2</sub>, HbC, HbO and HbE from one another, nor can HbD, HbG and Hb Lepore be differentiated from HbS (Fairbanks, 1980, Rich et al., 1979, Salmon et al., 1978). Therefore, it is normally used to screen for some types of Hb variants. The confirmatory test can be done using electrophoresis in acidic media. At a lower pH of about 6.0, a better separation of different hemoglobins is obtained. Those Hbs that co-migrate in alkaline pH electrophoresis can be separated in acidic media. Nevertheless, the main technique for Hb quantification by densitometric scanning of the gel is still somewhat difficult and unreliable (Fairbanks, 1980) and therefore electrophoresis technique has been used mainly for detection of Hb variants rather than measuring level of Hb in thalassemia diagnosis. It is highly specific in the detection of certain Hb disorders such as sickle cell disease. Even though the electrophoresis in acidic media is quite a powerful technique in separation of many types of Hbs, please

keep in mind that not all Hb variants can be separated by electrophoresis in acidic media. For example, Hb Okayama cannot be separated using electrophoresis, but can be done so in HPLC (Frers et al., 2000). Capillary electrophoresis is the new format of electrophoresis where separation takes place in a small fused silica capillary. It is rapid, easily automated and consumes low amounts of reagents, as compared to conventional gel electrophoresis. It also offers much higher throughput as compared to HPLC (Doelman et al., 1997). However, some researchers found that CE has higher instrumentation cost and is less accurate as compared to automated HPLC (Jenkins & Ratnaik, 2003). To perform electrophoresis of globin chains, a few steps need to be done in order to obtain free globin chains. First, heme is removed from hemoglobin by treating with mercaptoethanol. Then the four globin chains are split apart without denaturing them using 8 M urea.

#### 10.3.4 Electrophoresis of hemolysates on cellulose acetate (alkaline buffers)

In this method, erythrocyte hemolysate is electrophoresed on cellulose acetate in urea-2-mercaptoethanol buffers in the presence of additional 2-mercaptoethanol. The latter severs heme from globin, while the urea severs the  $\alpha$ - and non- $\alpha$ -globin chains, which migrate on the cellulose acetate according to their electrical charge. The method requires very small amounts of hemolysate, yet it provides excellent resolution of globin chains in alkaline (Ueda & Schneider, 1969).

The electrophoresis apparatus and sample plate, aligning base, applicator, dispenser, and cellulose acetate. Some prepared reagents-such as the pH 8.5 buffer (Supreheme),

**Solutions:** De-ionized water is used throughout. Concentrated citric acid: 300 g/liter.

**Hemolyzing reagent** was 1.0 g of tetrasodium ethylenediaminetetraacetate per liter of water containing 0.2 g of KCN per liter. Staining solution was 5 g of Ponceau S per liter of trichloroacetic acid solution (50 g/liter). Dilute acetic acid was 3 ml of glacial acetic acid plus 97 ml of water. Buffer solutions, All pH measurements are made at room temperature.

##### Alkaline-urea-mercaptoethanol-buffer solutions:

(i) Barbital buffer, pH 8.6, (ii) Tris-EDTA-boric acid buffer, pH 8.5, containing 10.2 g of Tris (about 80 mmol/liter), 0.6 g of EDTA, and 3.2 g of boric acid/liter, (iii) Tris-EDTA-boric acid buffer, pH 8.6, containing 18 g of Tris (about 150 mmol/liter), 2.3 g of EDTA, and 3 g of boric acid/liter.

To about 70 ml of each of these buffers, add 36 g of urea and stir on a mechanical stirrer until the urea dissolves. Adjust the volume (now about 98 ml) to 100 ml with additional buffer. In each case the final pH is about 8.9. These urea-containing buffers are used to dilute the hemolysate and soak the Titan III cellulose acetate. Just before placing buffers into the electrophoresis chambers, add 5 ml of 2-mercaptoethanol per liter.

Collect blood samples by venipuncture into a syringe with anticoagulant, or by finger stick into heparinized hematocrit tubes. Prepare hemolysates by adding one volume of water and 0.4 volume of toluene to one volume of saline-washed, packed erythrocytes. A more rapid alternative is to add three volumes of hemolyzing reagent to one volume of unwashed and sedimented or centrifuged cells (Titan III cellulose acetate plates). In most cases, however, erythrocyte hemolysates (5-10 g of hemoglobin per 100 ml) were electrophoresed directly. Add one volume of the appropriate urea buffer and one-half to one volume of undiluted 2-mercaptoethanol to one volume of hemolysate. (The additional mercaptoethanol is needed for removal of heme from globin.) Convenient volumes are 20  $\mu$ l each of hemolysate and urea-buffer, and 10 to 20  $\mu$ l of 2 mercaptoethanol. About 2  $\mu$ l of this mixture, after it has stood at room temperature for about 0.5 h but not longer than 4 h, are placed into the sample wells.

## Electrophoresis

**Preparation of cellulose acetate:** Mercaptoethanol may soften the Mylar backing of cellulose acetate gels, so soak the Titan III plates for several hours (or longer) in the appropriate urea-buffer without mercaptoethanol. Drain and soak for about 1 h in the corresponding urea-mercaptoethanol buffer, and finally drain and blot before applying samples. Soak Titan II sheets overnight (or longer) in the desired urea-mercaptoethanol buffer. Drain and blot. Application of samples and electrophoresis: Depress the tips of the sample applicators into the wells containing the hemolysate-urea-buffer-mercaptoethanol mixtures and wipe them off, then depress again. Make several trial applications on paper towels, until the lines formed are sufficiently thin. Then hold the applicator down for about 20 s on the Titan III plate positioned in the aligning base. When acid buffers are being used, apply samples about 1 cm from the anodal end of the plate; apply those in alkaline buffers centrally. Always include at least one control sample, usually Hb AS. In the electrophoresis chamber, rest the plates on wicks of filter paper; two or three plates may be analyzed simultaneously (200 to 350 V for 1 to 1.5 h), with a glass plate on each to weight it down.

### 10.3.5 Isoelectric focusing (IEF)

This technique is based on the electrophoresis technique but with a higher degree of separation. Different Hbs migrate in a pH gradient to the point where their net charges are zero. The order of migration is the same as in alkaline electrophoresis but the narrower bands obtained from this method (IEF) allow for the resolution of HbC, HbE, HbO, HbS, HbD and HbG (Laosombat et al., 2001, Gwendolyn et al., 2000). Two different formats of IEF, thin layer gel and capillary, have been reported (Hempe & Craver, 1994, Hempe et al., 1997). Cossu et al. (1982) applied the immobilized pH gradient method (IPG) with a thin layer gel that has a pH range of 6.7-7.6 to differentiate heterozygous from homozygous  $\beta$ -thalassemia in newborns. The group suggested the use of umbilical cord blood because it contains only HbF, HbA and acetylated HbF (HbFac) and the ratio of HbA:HbFac or HbF:HbA is used instead of the conventional  $\beta$ : $\alpha$  ratio in the IEF of globin chains.

**Isoelectric focusing ((IEF) Hicks & Hughes, 1975)**

#### Preparation of hemolysates for isoelectro focusing

The blood used for isoelectrofocusing was collected in vacutainers (Becton-Dickinson, Rutherford, N.J. 07070) with disodium ethylenediaminetetraacetate as anticoagulant. The erythrocytes were washed three times with NaCl solution (154 mmol/liter) and lysed with an equal volume of distilled water and 0.4 ml of toluene per milliliter of erythrocytes. The mixture was shaken for 5 min and the hemoglobin solution was cleared of cellular debris by centrifugation (20 min, 4586 x g). Isoelectric focusing was used to obtain purified hemoglobin biopolymers for our sensitivity studies, the procedure being essentially that recommended by Svensson (1962) and Ui (1971), performed at 4°C with use of carrier ampholytes (Ampholine, 10 g/liter; LKB-Produkter AB, Stockholm, Sweden) and an electrofocusing column (Model 8101, LKB-Produkter AB) of 440-ml capacity. Solutions and linear density gradients in the column were prepared manually. The dense solution used was a sucrose solution (670 g/liter) containing carrier ampholytes (20 g/liter); less-dense solution contained 4 g of carrier ampholytes per liter, with no sucrose. (i) The protein load applied varied from 60 to 80 mg, and the sample was introduced onto the column between the dense solution and the less-dense solution. (ii) The initial voltage was 200 V, the final voltage 750 V. The voltage was increased at 2-h intervals by 200-V increments to the final

voltage. (iii) Equilibrium was usually reached in 48 h. (iv) pH range from 6 to 8 was used, this range was used for isoelectrofocusing hemoglobins S, C, F, A, and D or G. (v) Fractions of 2 to 2.5 ml were collected and the absorbance of each fraction was read at 280 nm to identify the various isolated hemoglobin peaks. (vi) The pH of each fraction was determined at 25 °C with a pH meter. (vii) The separated hemoglobins were quantitated by measuring the absorbance at 415 nm with a spectrophotometer.

### **10.3.6 Capillaries Isoelectric focusing (cIEF)**

Capillary IEF showed very promising performance both in qualitative and quantitative aspects. A single IEF run can replace the main tests that normally have to be carried out in combination for qualitative and quantitative analysis of Hbs, for instance, alkaline and acid electrophoresis for major Hb variants, ion exchange chromatography for HbA2 quantification and alkaline resistant test for HbF (Hempe et al., 1997). It has been proven to have a comparable performance to chromatography or radioactive globin chain methods (Dubart et al., 1980) and can be used for analysis of hemoglobin variants in adult and newborn (Mario et al., 1998).

### **10.3.7 Flow cytometry**

Even though acid elution stain test seems to be simple, it is rather time consuming and subject to human error. The more precise and sensitive quantification of HbF can be done using the instrumental based flowcytometric technique (Mundee et al., 2000). The interested component of the cell is bound to a fluorescence label. Light scattering can identify the cell population of interest. Fluorescence intensity is measured to quantify the component of interest. The discovery of monoclonal antibody production has extended the use of flow cytometry. Antibody against HbF tagged with fluorescent dye can be used to specifically determine the amount of HbF. It has been demonstrated that detection of both a fetal cell surface antigen and HbF using two different monoclonal antibodies and two colored dyes is a precise way to identify the fetal cells (van Weeghel et al., 2000, Presented by Purdue University Cytometry Laboratories, Available: <http://www.wiley.com/legacy/products/subject/life/cytometry/isac2000/6730.htm>). The technique called gradient centrifugation has been proved to enrich the fetal cells from the adult blood and can extend the sensitivity of the flow cytometric analysis of HbF (Chen & Davis, 1997).

## **10.4 Advanced techniques for thalassemia and Hb variants**

These are advanced techniques used to detect thalassemia and Hb variants. They are complicated and expensive techniques which are used in the cases for which there are no other ways to accurately identify or confirm the types of thalassemia or Hb variants. They involve DNA technology that can provide in-depth detailed information of gene mutation.

### **10.4.1 Polymerase chain reaction (PCR)**

PCR selectively amplifies mutant or normal alleles using specific oligonucleotide primers. PCR is a technique that allows a small amount of DNA to be amplified *in vitro*. The process is composed of cycles of the three following steps: (i) perform heat denaturing to separate the DNA sequence target into two strands, (ii) anneal each strand to the specific primers and (iii) then extend the polymerase chain from the primer termini (Mathews & Holde, 1996). Once there are enough of the DNA target sequences produced for further analysis. DNA fragments can be separated by gel electrophoresis. That is commonly done following the



PCR to different DNA fragments. Many additional methods can be coupled with gel electrophoresis and PCR to obtain better information. Direct DNA sequencing of PCR products is quite a straight forward method to indicate the mutation site (Chern & Chen, 2000). Methods for the detection of point mutations were based on restriction fragment length polymorphism (RFLP) analysis (Saiki et al., 1985), and the effects of base-pair changes on DNA fragment melting temperature (denaturing gradient gel electrophoresis) (Fischer & Lerman, 1983). The RFLP technique can differentiate between different DNA sequences based on the length of fragments yielded by a particular enzyme restriction and can indicate the mutation point of a gene in thalassemia patients (Lee et al., 2002). The detection techniques have utilized allele-specific oligonucleotide (ASO) (Saiki et al., 1986, Conner et al., 1983) hybridization, the single-stranded conformational polymorphism (SSCP) (Orita et al 1989), amplification refractory mutation system (ARMS) (Newton et al., 1989), Primer-guided nucleotide incorporation assays (Hargrove et al., 1990, Takatsu et al., 2004), oligonucleotide ligation assay (Li et al., 2005), real time PCR (Cheng et al., 2004, Johnson et al., 2004), and DNA microarray technology (Wong et al., 2004, Meaburn et al., 2006). The ARMS-PCR, also known as allele specific PCR, is another technique that has been introduced to be used for thalassemia diagnosis. This technique utilizes two PCR reactions: one contains a primer specific for the normal allele and the other contains one for the mutant allele. Gel electrophoresis is then employed to separate specific DNA bands. The PCR products were separated in 2% agarose gel. The samples were mixed with gel loading buffer and then were slowly loaded into the slots of the agarose gel, which pre-stained with ethidium bromide. The gel then electrophoresed at 150 volts, 15 min for  $\alpha$ -thalassemia-1 (SEA type, THAI type), HbCS and HbPS and 150 volts, 25 min for  $\alpha$ -thalassemia-2 (3.7 and 4.2 kb deletion) to check the size of PCR product. The size of DNA fragment was checked by comparing the 100 bp or 1 Kb DNA size standard (New England BioLabs) at the same gel. The images were captured using gel documentation (Bio-Rad) under ultraviolet light. Diagnosis of genotyping is based on whether there is amplification in one or both reactions (i.e., the band in normal reaction only indicates normal allele, the band in mutant reaction only indicates mutant allele, and bands in both reactions indicate a heterozygote) (Kanavakis et al., 1997, Old et al., 2000, Simsek et al., 1999). ARMS-PCR is more accurate as compared to RFLP. Single stranded conformation polymorphism (SSCP) is the technique that was developed based on the fact that the mobility in gel electrophoresis of single strands of DNA drastically depends on nucleotide sequence. Single stranded DNA is produced by adding one primer at a concentration higher than another primer in the PCR step. After the primer with lower amount is used up, the reaction will continue producing only the product of the excess primer. The mobilities of single strands are then compared (Takahashi-Fujii et al., 1994). Single stranded DNA may also be produced by denaturing double stranded DNA, as in the technique called denaturing gradient gel electrophoresis (DGGE) (Kanavakis et al., 1997, Vrettou et al., 1999, Losekoot et al., 1990). Table 9 showed some examples of PCR primers for used in thalassemia diagnosis and table 10 summarized of common genotype in thalassemia syndrome in Thailand.

#### 10.4.2 DNA sequencing analysis for $\beta$ -thalassemia mutation

DNA polymerase amplifies single-stranded DNA templates, by adding nucleotides to a growing chain (extension product). Chain elongation occurs at the 3' end of a primer, an oligonucleotide that anneals to the template. The deoxynucleotide added to the extension product is selected by base-pair matching to the template. When a dideoxynucleotide is

incorporated at the 3' end of the growing chain, chain elongation is terminated selectively at A, C, G or T because the chain lacks a 3'-hydroxyl group. With 3'-dye labeled dideoxynucleotide (dye terminators), DNA sequencers detect fluorescence from four different dyes that are used to identify the A,C,G and T extension reactions. All four colors and therefore all four bases can be detected and distinguished in a single gel lane and displayed in color peak of bases.

Primers	Diagnosis	Reference
<b>P1 (sense):</b> 5'-GCGATCTGGGCTCTGTGTTCT-3' <b>P2 (antisense):</b> 5'-GTTCCCTGAGCCCCGACATG-3' <b>P3 (antisense):</b> 5'-GCCTTGAACTCCTGGACTTAA-3'	$\alpha^0$ -thalassemia (SEA type), (--SEA)	2008; 54:281
<b>P1 (sense):</b> 5'-CCTCCTGGGATTACATCTGG-3' <b>P2 (antisense):</b> 5'-GCACCTCTGGGTAGGTTCTG-3' <b>P3 (sense):</b> 5'-CCCCTGACAATCTCATCACT-3'	$\alpha^0$ -thalassemia (THAI type), (--THAI)	2005; 8(3): 241
<b>P1 (sense):</b> 5'-AAGTCCACCCCTTCCTTCCTCACC-3' <b>P2 (antisense):</b> 5'-ATGAGAGAAATGTTCTGGCACCTGCACTTG-3' <b>P3 (antisense):</b> 5'-TCCATCCCCTCCTCCCGCCCCTGCCTTTTC-3'	$\alpha^+$ -thalassemia (3.7 kb deletion), (- $\alpha$ 3.7)	2005; 8(3): 241
<b>P1 (sense):</b> 5'-TCTTGATCTTTGAATGAAGTCCGAGTAGGC-3' <b>P2 (antisense):</b> 5'-TGGGGGTGGGTGTGAGGAGACAGGAAAGAGAGA-3' <b>P3 (antisense):</b> 5'-ATCACTGATAAGTCATTTCTGGGGTCTG-3'	$\alpha^+$ -thalassemia (4.2 kb deletion), (- $\alpha$ 4.2)	2005; 8(3): 241
<b>P1 (sense):</b> 5'-GCTGACCTCCAAATACCGTC-3' <b>P2 (antisense):</b> 5'-GTAAACACCTCCATTGTTGG-3'	ARMS for HbCS	2005; 8(3): 241
<b>P1 (sense):</b> 5'-GCTGACCTCCAAATACCGTTAT-3' <b>P2 (antisense):</b> 5'-GTAAACACCTCCATTGTTGG-3'	ARMS for HbPS	2005; 8(3): 241

Table 9. Some examples of PCR primers for used in thalassemia diagnosis

#### 10.4.3 DNA technology: DNA probe/DNA microchip

Analysis of nucleic acids has led to the understanding of the gene expression that controls Hbs formation. This information is more detailed as compared to information obtained from protein analysis that normally only suggests type and amount of different Hbs production. The advance of DNA studies and fabrication technology together has led to the development of methods for diagnosis using a DNA microchip. Normally the segment of a gene of interest first has to be amplified by PCR to obtain a sufficient amount prior to hybridization with allele specific oligonucleotide probes that are immobilized on the solid phase or chip (Bianchi et al., 1997, Saiki et al., 1988, Fotin et al., 1998). The bound target gene

can be detected using either labels such as fluorescent substances (Kurg et al., 2000, Kobayashi et al., 1995) or electronic transducers such as piezoelectronic and ion sensitive field effect transistors (ISFETs) (Cailloux, Novel DNA Chips. Patent No. WO/ 2001/064945 (2001)). One example of devices that has been used commonly is a cytometer. Cytometry is a laser based technique that allows for analysis of physical properties and fluorescence intensity of an individual cell in a heterogeneous environment. The image can differentiate different types of cells or DNA sequences that are labeled with different colors by comparing the ratios of fluorescence of different targets. With the aid of a computer, detection and visualization of many different probes can be done simultaneously (Osterhout et al., 1996, Janssen & Hoffmann, 2002).

Phenotype	Common genotype
<b><math>\alpha</math>-Thalassemia</b>	
Thalassemia minor	--/ $\alpha\alpha$ Heterozygous $\alpha$ -thalassemia-1
Silent Carrier	- $\alpha$ / $\alpha\alpha$ Heterozygous $\alpha$ -thalassemia-2
Hb Bart's hydrops fetalis	--/-- Homozygous $\alpha$ -thalassemia-1
Thalassemia minor	- $\alpha$ / - $\alpha$ Homozygous $\alpha$ -thalassemia-2
Hb H disease	--/ - $\alpha$ $\alpha$ -thalassemia 1/ $\alpha$ -thalassemia-2
Hb H disease	--/ $\alpha^{CS} \alpha$ $\alpha$ -thalassemia 1/Hb Constant spring
<b><math>\beta</math>-Thalassemia</b>	
Thalassemia minor	Heterozygous $\beta^0$ -thalassemia
Thalassemia minor	Heterozygous $\beta^+$ -thalassemia
Thalassemia major	Homozygous $\beta^0$ -thalassemia
Thalassemia intermedia	$\beta^0$ -thalassemia/ $\beta^+$ -thalassemia
Thalassemia intermedia or	
Thalassemia major	Hb E- $\beta^0$ -thalassemia
Thalassemia intermedia	Hb E- $\beta^+$ -thalassemia

Table 10. Summarized of common genotype in thalassemia syndromes in Thailand

### 10.5 Indirect thalassemia indication and treatment follow-up

These studies are not to be used for thalassemia diagnosis. However, the relevance of the variable of interest and the existence of thalassemia may help treatment follow-up or a new way to economically test for thalassemia.

#### 10.5.1 Ferritin

Ferritin is the iron storage protein serves to store iron in a non-toxic form, to deposit it in a safe form, and to transport it to areas where it is required. Ferritin level in serum directly relates to the amount of iron stored in the body, which is important for red blood cell production. If ferritin is high, there is iron in excess. Ferritin is also used as a marker for iron overload disorders. Normal ranges of ferritin are 12-300 and 12-150 ng ml<sup>-1</sup> for male and female, respectively (Medlineplus, Medical Encyclopedia, The US National Library of Medicine and the National Institutes of Health. Available: <http://www.nlm.nih.gov/medlineplus/ency/article/003490.htm> (October 16, 2003). The technique commonly used to quantify ferritin is immunoassay (Konjin et al., 1981). A significantly high level of ferritin is found in patients with iron overload and this may help differentiate thalassemia patients from those with iron deficiency, both of which will have a low red blood cell count (Arosio et al., 1981). In addition, any inflammatory disorder can

cause a high level of ferritin, act as an acute phase protein. Therefore, long term monitoring of ferritin would be necessary, to gain any additional information for thalassemia diagnosis or treatment follow-up (Telfer et al., 2000).

### 10.5.2 Nuclear magnetic resonance spectroscopy

The nuclear magnetic resonance technique is the determination of the transverse relaxation time of hepatic water. That is based on the magnetic properties of some nuclei that when placed in the magnetic field, would take up radio frequency energy that matches the magnetic field strength and later re-emit that energy (Gunzler & Williams, 2001). The phenomenon is known as nuclear magnetic resonance (NMR) because it involves the nucleus in a magnetic field that has its strength in resonance with the applied radio frequency. NMR spectroscopy was used for the study of composition of chemical compounds. Later, the technique was developed into the imaging technology, magnetic resonance imaging (MRI), that became a major breakthrough in medical fields because it can reveal the image of the parts of the body and seems to be the most sensitive means at present. NMR has been widely applied to study body iron overload (Jensen et al., 1994, Mazza et al., 1995, Dixon et al., 1994). NMR spectroscopy has been employed mainly for study of iron level in the fraction of tissue in vitro such as liver, spleen, heart, while NMR imaging has been used mainly for determination of iron in vivo, it is an accurate method of measuring liver iron content, especially when the iron content is below 3% (Dixon et al., 1994). So far, there has been no report on health hazards directly related or side effects to NMR and therefore the NMR technique is considered a safe and non-invasive way to study body iron content with an excellent means of assessing the effectiveness of the various therapeutic strategies used in the management of patients with iron overload.

### 10.5.3 Whatman 3 MM dried blood spots for identifying $\alpha$ -Thalassemia-1 (as demonstrated by Tangvarasittichai et al., (2008))

This method using small samples spotted onto Whatman 3 MM paper (Whatman chromatography paper, Whatman International Ltd, UK) for measurement of  $\alpha$ -Thalassemia-1 by polymerase chain reaction (PCR) method. Forty-microliters of whole blood were multiple spotted onto Whatman 3 MM paper, and let dry at room temperature for a minimum of 3 hours, stored in sealed plastic bag at room temperature until the day of assay every month for 6 months. DNA extraction was extracted by Chelex method. The dried blood spot was cut into 3 pieces while for the whole blood test 40  $\mu$ l of whole EDTA blood was used. Added 1 ml of lysis buffer (1% triton X-100) in a 1.5 ml tube, vortexed and centrifuged at 10,000 g for 1 min, discharged the supernatant and washed the pellets by using 1 ml distilled water and the resuspended in 100  $\mu$ l of distilled water with the addition of 1 drop of Chelex  $\text{\textcircled{R}}$  solution. Mixtures were incubated at 56°C for at least 2 hr before being boiled for 5-10 minutes, Samples were spun down by brief centrifugation. Extracted DNA was stored at 4°C until used. PCR reaction had a volume of 10  $\mu$ l and contained 1  $\mu$ l of 10x Tris buffer, 1  $\mu$ l of 25 mmol/l KCl, 1  $\mu$ l of glycerol, 1  $\mu$ l of 2 mmol/l of each dATP, dCTP, dGTP, dTTP, 1  $\mu$ l of 5  $\mu$ mol/l of 3 primers, 5  $\mu$ l of DNA solution and 0.1  $\mu$ l of 5 U/ $\mu$ l *Taq* polymerase. The composition of the 3 primers is

P1: 5'-GCGATCTGGGCTCTGTGTTCT-3',

P2: 5'-GTTCCCTGAGCCCCGACACG-3',

P3: 5'-GCCTTGAACCTCCTGGATTAA-3'

The cycling conditions 94 °C for 5 min followed by 40 cycles of amplification, denaturing at 94°C for 40 sec, annealing at 56°C for 40 sec and extension at 72°C for 40 sec. The last cycle extension time was 5 min. The PCR was analyzed by electrophoresis on 2% agarose gel and DNA bands were detected with ethidium bromide by UV transilluminator.  $\alpha$ -Thalassemia-1 trait (SEA-type) showed a specific 188 bp fragment in addition to a 314 bp fragment obtained from the normal DNA sequence.

## 11. Conclusion

The rapid increase in understanding of the pathophysiology of thalassemia, diseases of the globin gene have served as a model for the understanding of gene expression and regulation at the molecular level and this knowledge forms the basis for therapeutic interventions, such as gene therapy and augmentation of abnormal hemoglobin levels. Clinical interventions for the treatment of thalassemia patients have also progressed. We have a better knowledge of the optimal amount and method of treatment to provide (such as transfusions and desferrioxamine), as well as of the side-effects of these treatments. Then, the early or prenatal diagnosis of thalassemia is very important, it may base on hematologic and molecular genetic testing. There are many different techniques available for thalassemia diagnosis, but used alone they may not be able to ensure the diagnostic result. Therefore, it is quite common to utilize more than one technique for thalassemia diagnosis. In Fig. 4 summarizes techniques commonly used for diagnosis of Hb variants and thalassemia in most laboratories. If MCV, MCH or OFT screening test reveals a normal result, the possibility of having thalassemia can be eliminated, but analysis of Hb variants should be done. If an abnormal result is obtained from the screening test, there is a possibility of having either Hb variants or thalassemia case. If Hb variants tests do not show any abnormal results, thalassemia tests should still be performed. Choices of techniques depend mainly on budget and equipment available. It should be pointed out that even in laboratories equipped with high technology and many years of experience, quite a few false diagnoses were reported, which resulted in the births of thalassemia children or to have genetic counseling for abortions the unaffected fetuses. It is very important to take precaution in every step of the diagnostic procedures to ensure the most accurate diagnosis. Developments in chemical analysis methodologies are still very useful to this field.

## 12. References

- Aessopos, A, Stamatelos, G, Skoumas, V, Vassilopoulos G, Mantzourani M, et al. (1995). Pulmonary hypertension and right heart failure in patients with  $\beta$ -thalassemia intermedia. *Chest*, 107, p.p.50-53.
- Ali, SA. (1969). Hemoglobin H disease in Arabs in Kuwait. *J Clin Pathol*, 22, p.p. 226 - 228.
- Allen, S. J., O'Donnell, A., Alexander, N. D. E., Alpers, M. P., Peto, T. E. A., et al. (1997).  $\alpha^+$ -Thalassemia protects children against disease caused by other infections as well as malaria. *PNAS*, 94, p.p.14736 - 14741.
- Allison, A.C. (1954). Protection Afforded by Sickle-cell Trait Against Subtertian Malarial Infection. *Br Med J*, 1, p.p. 290 - 294.
- Anapliotou, M.L.G., Kastanias, I.T., Psara, P., Evangelou, E.A., Liparaki, M., et al. (1995). The contribution of hypogonadism to the development of osteoporosis in thalassaemia major: new therapeutic approaches. *Clin Endocrinol (Oxf)*, 42, p.p. 279-287.

- Anderson, L.J., Westwood, M.A., Holden, S., Davis, B., Prescott, E., et al. (2004). Myocardial iron clearance during reversal of siderotic cardiomyopathy with intravenous desferrioxamine: a prospective study using T2\* cardiovascular magnetic resonance. *Br J Haematol*, 127(3), p.p. 348-355.
- Angelucci, E., Giovagnoni, A., Valeri, G., Paci, E., Ripalti, M., et al. (1997). Limitations of Magnetic Resonance Imaging in Measurement of Hepatic Iron. *Blood*, 90, p.p. 4736-4742.
- Angelucci, E., Brittenham, G.M., McLaren, C.E., Ripalti, M., Baronciani, D., et al. (2000). Hepatic iron concentration and total body iron stores in thalassemia major. *N Engl J Med*, 343(5), p.p. 327-331.
- Arosio, P., Iacobello, C., Montesoro, E., & Albertini, A. (1981). Serum ferritin evaluation with radioimmunoassays specific for HeLa and liver ferritin types. *Immunol Lett*, 3(5), p.p. 309-313.
- Aslan, M. & Freeman, B.A. (2004). Oxidant-mediated impairment of nitric oxide signaling in sickle cell disease-mechanisms and consequences. *Cell Mol Biol*, 50(1), p.p. 95-105.
- Bacon, B.R., Tavill, A.S., Brittenham, G.M., Park, C.H., & Recknagel, R.O. (1983). Hepatic lipid peroxidation in vivo in rats with chronic iron overload. *J Clin Invest*, 71(3), p.p. 429-439.
- Bain, B.J. (2006). *Hemoglobinopathy Diagnosis*. 2nd ed. Malden, Mass.: Blackwell Publishing, p. 66.
- Betke, K. & Sanguanserm, T. (1972). Cytological differentiation of blood pigments. Possibilities, results and practical application. *Munch Med Wochenschr*, 114(23), p.p. 1099-1104.
- Betke, K., Marti, H.R., & Schlicht, I. (1959). Estimation of small percentages of foetal hemoglobin. *Nature*, 184(Suppl 24), p.p. 1877-1878.
- Bianchi, D.W., Williams, J.M., Sullivan, L.M., Hanson, F.W., Klinger, K.W., et al. (1997). PCR quantitation of fetal cells in maternal blood in normal and aneuploid pregnancies. *Am J Hum Genet*, 61(4), p.p.822-829.
- Borgna-Pignatti, C. & Galanello, R. (2004). *Thalassemias and related disorders: quantitative disorders of hemoglobin synthesis*. In Wintrobe's Clinical Hematology Volume 42. 11th edition. Lippincott Williams & Wilkins. Philadelphia, p.p. 1319-1365.
- Borgna-Pignatti, C., Rugolotto, S., De Stefano, P., Zhao, H., Cappellini, M.D., et al. (2004). Survival and complications in patients with thalassemia major treated with transfusion and deferoxamine. *Haematologica*, 89, p.p. 1187 - 1193.
- Brilliant cresyl blue MSDS sheet, Available: <http://www.proscitech.com/catalogue/msds/c085.pdf> (April 14, 2003).
- Brittenham, G.M., Cohen, A.R., McLaren, C.E., Martin, M.B., Griffith, P.M., et al. (1993). Hepatic iron stores and plasma ferritin concentration in patients with sickle cell anemia and thalassemia major. *Am J Hematol*, 42(1), p.p. 81-85.
- Britton, R.S.; Bacon, B.R. & Recknagel, R.O. (1987). Lipid peroxidation and associated hepatic organelle dysfunction in iron overload. *Chem Phys Lipids*, 45(2-4), p.p. 207-239.
- Brosious, E.M., Wright, J.M., Baine, R.M., & Schmidt, R.M. (1978). Micro-chromatographic methods for hemoglobin A2 quantitation compared. *Clin. Chem*, 24, p.p. 2196 - 2199.
- Brosious, E.M., Morrison, B.Y., & Schmidt, R.M. (1976). Effects of hemoglobin F levels, KCN, and storage on the isopropanol precipitation test for unstable hemoglobins. *Am J Clin Pathol*, 66(5), p.p. 878-882.
- Buja, L.M. & Roberts, W. (1971). Iron in the heart: etiology and clinical significance. *Am J Med*, 51, p.p.209-221.

- Cailloux, F. *Novel DNA Chips*. Patent No. WO/ 2001/064945 (2001).
- Cao, A.; Galanello, R. & Rosatelli, M.C. (1998). Prenatal diagnosis and screening of the hemoglobinopathies. *Baillieres Clin Haematol*, 11(1), p.p. 215-238.
- Carrell, R.W. & Kay, R. (1972). A simple method for the detection of unstable hemoglobins. *Br J Haematol*, 23(5), p.p. 615-619.
- Cavallo-Perin, P., Pacini, G., Cerutti, F., et al. (1995). Insulin resistance and hyperinsulinemia in homozygous  $\beta$ -thalassemia. *Metabolism*, 44, p.p. 281-286.
- Chakraborty, D. & Bhattacharyya, M. (2001). Antioxidant defense status of red blood cells of patients with beta-thalassemia and Ebeta-thalassemia. *Clin Chim Acta*, 305(1-2), p.p. 123-129.
- Chan, V., Chan, V.W., Tang, M., Lau, K., Todd, D., et al. (1997). Molecular defects in Hb H hydrops fetalis. *Br J Haematol*, 96(2), p.p. 224-228.
- Chen, J.C. & Davis, B.H. (1997). Characterization of fetal hemoglobin containing cells by density gradient centrifugation and flow cytometric analysis. *Clinical Immunology Newsletter*, 17(6), p. 88.
- Cheng, J.; Zhang, Y. & Li, Q. (2004). Real-time PCR genotyping using displacing probes. *Nucleic Acids Res*, 32, p. e61.
- Chern, S.R. & Chen, C.P. (2000). Molecular prenatal diagnosis of thalassemia in Taiwan. *Int J Gynaecol Obstet*, 69(2), p.p. 103-106.
- Chernoff, A.I. (1959). The Distribution of the Thalassemia Gene: A Historical Review. *Blood*, 14, p.p. 899 - 912.
- Chinprasertsuk, S., Wanachiwanawin, W. & Piankijagum, A. (1994). Effect of pyrexia in the formation of intraerythrocytic inclusion bodies and vacuoles in haemolytic crisis of hemoglobin H disease. *Eur J Haematol*, 52, p.p.87-91.
- Christian, G.D. (2004). *Analytical Chemistry*, 6th ed., Wiley, New York.
- Chui, D.H.K. & Wayne, J.S. (1998). Hydrops Fetalis Caused by  $\alpha$ -Thalassemia: An Emerging Health Care Problem. *Blood*, 91, p.p. 2213 - 2222.
- Congote, L.F. (1981). Rapid procedure for globin chain analysis in blood samples of normal and beta-thalassemic fetuses. *Blood*, 57, p.p. 353 - 360.
- Conner, B.J., Reyes, A.A., Morin, C., Itakura, K., Teplitz, R.L., et al. (1983). Detection of Sickle Cell  $\beta$  S-globin Allele by Hybridization with Synthetic Oligonucleotides. *PNAS*, 80, p.p. 278 - 282.
- Cooley, T.B.; Witwer, E. R. & Lee, P. (1927). Anemia in children: With splenomegaly and peculiar changes in the bones report of cases. *Am J Dis Child*, 34, p.p. 347 - 363.
- Cooley, T.B. (1946). M.D. 1871-1945. *Am J Dis Child*, 71, p.p. 77 - 79.
- Cossu, G., Manca, M., Pirastru, M.G., Bullitta, R., Bosisio, A.B., et al. (1982). Neonatal screening of beta-thalassemias by thin layer isoelectric focusing. *Am J Hematol*, 13(2), p.p. 149-157.
- Cunningham, M.J., Macklin, E.A., Neufeld, E.J., Cohen, A.R., & the Thalassemia Clinical Research Network. (2004). Complications of  $\beta$ -thalassemia major in North America. *Blood*, 104, p.p. 34 - 39.
- Dacie, J.V, Grimes, A.J., Meisler, A., Stiengold, L., Hemsted, E.H., et al. (1964). Hereditary heinz-body zanaemia. A report of studies on five patients with mild anaemia. *Br J Haematol*, 10, p.p. 388-402.
- Dispenzieri, A. (2001). *Primary Hematology*, Humana Press, NJ.
- Dixon, R.M., Styles, P., al-Refaie, F.N., Kemp, G.J., Donohue, S.M., et al. (1994). Assessment of hepatic iron overload in thalassemic patients by magnetic resonance spectroscopy. *Hepatology*, 19(4), p.p. 904-910.

- Doelman, C.J.A, Siebelder, C.W.M., Nijhof, W.A., Weykamp, C.W., Janssens, J., et al. (1997). Capillary electrophoresis system for hemoglobin A1c determinations evaluated. *Clin Chem*, 43, p.p. 644 - 648.
- Dover, G.J., Boyer, S.H., & Zinkham, W.H. (1979). Production of erythrocytes that contain fetal hemoglobin in anemia. Transient in vivo changes. *J Clin Invest*, 63(2), p.p. 173-176.
- Dozy, A.M., Kleihauer, E.F., & Huisman, T.H. (1968). Studies on the heterogeneity of hemoglobin. 13. Chromatography of various human and animal hemoglobin types on DEAE-Sephadex. *J Chromatogr*, 32(4), p.p. 723-727.
- Du, Z.D., Roguin, N., Milgram, E., Saab, K., & Koren, A. (1997). Pulmonary hypertension in patients with thalassemia major. *Am Heart J*, 134, p.p.532-537.
- Dubart, A., Goossens, M., Beuzard, Y., Monplaisir, N., Testa, U., et al. (1980). Prenatal diagnosis of hemoglobinopathies: comparison of the results obtained by isoelectric focusing of hemoglobins and by chromatography of radioactive globin chains. *Blood*, 56: p.p. 1092 - 1099.
- Eaton, J.W. & Qian, M. (2002). Molecular bases of cellular iron toxicity. *Free Radic Biol Med*, 32(9), p.p. 833-840.
- Electron Microscope Sciences Catalog, Available: <http://www.emsdiasum.com/ems/chemicals/salt.html> (October 16, 2003).
- Factor, J.M., Pottipati, S.R., Rappaport, I., Rosner, I.K., Lesser M.L., et al. (1994). Pulmonary function abnormalities in thalassemia major and the role of iron overload. *Am J Respir Crit Care Med*, 149, p.p.1570-1574.
- Fairbanks, V.J. (1980). *Hemoglobinopathies and Thalassemia Laboratory Methods and Clinical Cases*, Brian C. Decker, New York.
- Fernandez-Alberti A. & Fink, N.E. (2000). Red blood cell osmotic fragility confidence intervals: a definition by application of a mathematical model. *Clin Chem Lab Med*, 38(5), p.p. 433-436.
- Fischer, S.G. & Lerman, L.S. (1983). DNA Fragments Differing by Single Base-Pair Substitutions are Separated in Denaturing Gradient Gels: Correspondence with Melting Theory. *PNAS*, 80, p.p. 1579 - 1583.
- Flint, J, Harding, R.M, Boyce, A.J. & Clegg, J.B. (1998). The population genetics of the hemoglobinopathies. *Baillieres Clin Haematol*, 11(1), p.p. 1-51.
- Fosburg, M.T. & Nathan, D.G. (1990). Treatment of Cooley's anemia. *Blood*, 76, p.p. 435 - 444.
- Fotin, A.V, Drobyshev, A.L., Proudnikov, D.Y., Perov, A.N., & Mirzabekov, A.D. (1998). Parallel thermodynamic analysis of duplexes on oligodeoxyribo- nucleotide microchips. *Nucleic Acids Res*, 26, p.p. 1515 - 1521.
- Frers, C.R., Dorn, S., Schmidt, W., Kochhan, L., Simon-Schultz, J., et al. (2000). Falsely increased HbA1c values by HPLC and falsely decreased values by immunoassay lead to identification of Hb Okayama and help in the management of a diabetic patient. *Clin Lab*, 46(11-12), p.p. 569-573.
- Fucharoen, S. & Winichagoon, P. (2000). Clinical and hematologic aspects of hemoglobin E beta-thalassemia. *Curr Opin Hematol*, 7(2), p.p. 106-112.
- Fucharoen, S., Winichagoon, P., Wisedpanichkij, R., Sae-Ngow, B., Sriphanich, R., et al. (1998). Prenatal and postnatal diagnoses of thalassemias and hemoglo-binopathies by HPLC. *Clin Chem*, 44: p.p.740 - 748.
- Fucharoen, S., Winichagoon, P., Pootrakul, P., Piankijagum, A., & Wasi, P. (1988). Difference between two types of Hb H disease,  $\alpha$ -thalassemia 1/ $\alpha$ -thalassemia 2 and  $\alpha$ -thalassemia 1/Hb Constant Spring. *Birth Defect. ;23* (5A), p.p. 309-315.



- Fucharoen, S. & Viprakasit, V. (2009) Hb H disease: clinical course and disease modifiers *Hematology*, 2009, p.p. 26 - 34.
- Gaziev, J. & Lucarelli G. (2003). Stem cell transplantation for hemoglobinopathies. *Curr Opin Pediatr*, 15(1), p.p. 24-31.
- Greenberg, M.S., Harvey, H.A. & Morgan, C. (1972). A simple and inexpensive screening test for sickle hemoglobin. *N Engl J Med*, 286(21), p.p. 1143-1144.
- GU<sup>n</sup> nzler, H. & Williams A. (2001). *Handbook of Analytical Techniques*, vol.1, Wiley VCH, Germany, p. 509.
- Gullo, L., Corcioni, E., Brancati, C., Bria, M., Pezzilli, R., et al. (1993). Morphologic and functional evaluation of the exocrine pancreas in  $\beta$ -thalassemia major. *Pancreas*, 8, p.p.176-80.
- Gwendolyn, M.C, Clarke, G.M. & Higgins, T.N. (2000). Laboratory Investigation of Hemoglobinopathies and Thalassemias: Review and Update. *Clin Chem*, 46, p.p. 1284 - 1290.
- Hargrove, J.L., Hulsey, M.G., Schmidt, F.H., and Beale, E.G. (1990). A computer program for modeling the kinetics of gene expression. *Biotechniques*, 8(6), p.p. 654-659.
- Hebbel, R.P., Eaton, J.W., Balasingam, M., & Steinberg, M.H. (1982). Spontaneous oxygen radical generation by sickle erythrocytes. *J Clin Invest*, 70(6), p.p. 1253-1259.
- Helrich, K. (1995). Association of Official Analytical Chemists, AOAC Inc., Virginia.
- Hempe, J.M. & Craver R.D. (1994). Quantification of hemoglobin variants by capillary isoelectric focusing. *Clin Chem*, 40, p.p. 2288 - 2295.
- Hempe, J.M., Granger, J.N., & Craver, R.D. (1997). Capillary isoelectric focusing of hemoglobin variants in the pediatric clinical laboratory. *Electrophoresis*, 18(10), p.p. 1785-95.
- Hershko, C, Konijn, A.M. & Link, G. (1998). Iron chelators for thalassaemia. *Br J Haematol*, 101, p.p.399-406.
- Hershko C, Weatherall DJ. (1988). Iron-chelating therapy. *Crit Rev Clin Lab Sci*, 26, p.p.303-345.
- Hicks, E.J. & Hughes, B.J. (1975). Comparison of electrophoresis on citrate Agar, cellulose acetate, or starch for hemoglobin identification. *Clin Chem*, 21(8), p.p. 1072-1076
- Higgs, D.R., Vickers, M.A., Wilkie, A.O., Pretorius, I.M., Jarman, A.P., et al. (1989). A review of the molecular genetics of the human alpha-globin gene cluster. *Blood*, 73, p.p. 1081 - 1104.
- Hillman, R.S. & Ault, K.A. (1995). *Hematology in Practical Practice, a Guide to Diagnosis and Management*, McGraw-Hill, New York,
- Houglum, K, Filip, M., Witztum, J.L., & Chojkier, M. (1990). Malondialdehyde and 4-hydroxynonenal protein adducts in plasma and liver of rats with iron overload. *J Clin Invest*, 86(6), p.p. 1991-1998.
- Huisman, T.H.J. & Dozy, A.M. (1965). Studies on the heterogeneity of hemoglobin: IX. The use of tris(hydroxymethyl)aminomethane-HCl buffers in the anion-exchange chromatography of hemoglobins. *J Chromatography A*, 19, p.p. 160-169
- Iancu, T.C, Neustein, H.B. & Landing, B.H. (1977). *The liver in thalassaemia major: ultrastructural observations*. In: Iron metabolism: Ciba Symposium 51. Amsterdam: Elsevier, p.p. 293-309.
- Italian Working Group on Endocrine Complications in Non-endocrine Diseases. (1995). Multicentre study on prevalence of endocrine complications in thalassaemia major. *Clin Endocrinol (Oxf)*, 42, p.p.581-586.
- Janssen, W.C. & Hoffmann, J.J. (2002). Evaluation of flow cytometric enumeration of foetal erythrocytes in maternal blood. *Clin Lab Haematol*, 24(2), 89-92.

- Jean, G., Terzoli, S., Mauri, R., et al. (1984). Cirrhosis associated with multiple transfusions in thalassaemia. *Arch Dis Child*, 59, p.p. 67-70.
- Jenkins, M. & Ratnaike, S. (2003). Capillary electrophoresis of hemoglobin. *Clin Chem Lab Med*, 41(6), p.p. 747-54.
- Jensen, P.D., Jensen, F.T., Christensen, T., & Ellegaard, J. (1994). Non-invasive assessment of tissue iron overload in the liver by magnetic resonance imaging. *Br J Haematol*, 87(1), p.p. 171-184.
- Johnson, M.P., Haupt, L.M. & Griffiths, L.R. (2004). Locked nucleic acid (LNA) single nucleotide polymorphism (SNP) genotype analysis and validation using real-time PCR. *Nucleic Acids Res*, 32, p. e55.
- Kadiiska, M.B., Burkitt, M.J., Xiang, Q.H., & Mason, R.P. (1995). Iron supplementation generates hydroxyl radical in vivo. An ESR spin-trapping investigation. *J Clin Invest*, 96(3), p.p. 1653-1657.
- Kanavakis, E., Traeger-Synodinos, J., Vrettou, C., Maragoudaki, E., Tzetis, M., et al. (1997). Prenatal diagnosis of the thalassaemia syndromes by rapid DNA analytical methods. *Mol Hum Reprod*, 3: p.p. 523 - 528.,
- Karydis, I., Karagiorga-Lagana, M., Nounopoulos, C., & Tolis, G. (2004). Basal and stimulated levels of growth hormone, insulin-like growth factor-I (IGF-I), IGF-I binding and IGF-binding proteins in beta-thalassemia major. *J Pediatr Endocrinol Metab*, 17(1), p.p. 17-25.
- Kazazian, Jr. H.H. (1990). The thalassemia syndromes: molecular basis and prenatal diagnosis in 1990. *Semin Hematol*, 27(3), p.p. 209-228.
- Klee, G.G., Behrman, R.E., Kliegman, R. & Jenson, H.B. (2000). *Nelson Textbook of Pediatrics*, W.B. Saunders.
- Klee, G.G. (1980). *Role of Morphology and Erythrocyte Indices in Screening and Diagnosis*, Brian C. Decker, a Division of Thieme-Stratton Inc, New York.
- Kobayashi, M., Rappaport, E., Blasband, A., Semeraro, A., Sartore, M., et al. (1995). Fluorescence-based DNA minisequence analysis for detection of known single-base changes in genomic DNA. *Mol Cell Probes*, 9(3), p.p. 175-182.
- Konjin, A.M., Levy, R., Link, G. & Hershko C. (1982). A rapid and sensitive ELISA for serum ferritin employing a fluorogenic substrate. *J Immunol Methods*, 54(3), p.p. 297-307.
- Kremastinos, D.T., Tiniakos, G., Theodorakis, G.N., Katritsis, D.G. & Toutouzas, P.K. (1995). Myocarditis in  $\beta$ -thalassaemia major: a cause of heart failure. *Circulation*, 91, p.p. 66-71.
- Kurg, A., Tonisson, N., Georgiou, I., Shumaker, J., Tollett, J., et al. (2000). Arrayed primer extension: solid-phase four-color DNA resequencing and mutation detection technology. *Genet Test*, 4(1), p.p. 1-7.
- Kutlar, F, Reese, A.L., Hsia, Y.E., Kleman, K.M. & Huisman, T.H. (1989). The types of hemoglobins and globin chains in hydrops fetalis. *Hemoglobin*, 13(7-8), p.p. 671-183.
- La-Nasa, G., Argioli, F., Giardini, C., Pession, A., Fagioli, F., et al. (2005). Unrelated bone marrow transplantation for beta-thalassemia patients: The experience of the Italian Bone Marrow Transplant Group. *Ann NY Acad Sci*, 1054, p.p. 186-195.
- Laosombat, V, Wongchanchailert, M., Sattayasevana, B., Wiriyasateinkul, A. & Fucharoen, S. (2001). Clinical and hematologic features of beta<sup>0</sup>-thalassaemia (frameshift 41/42 mutation) in Thai patients. *Haematologica*, 86, p.p. 138 - 141.
- Lee, Y.J., Park, S.S., Kim, J.Y. & Cho, H.I. (2002). RFLP haplotypes of beta-globin gene complex of beta-thalassemic chromosomes in Koreans. *J Korean Med Sci*, 17(4), p.p. 475-478.

- Leung, W.C., Leung, K.Y., Lau, E.T., Tang M.H. & Chan, V. (2008). Alpha-thalassaemia. *Semin Fetal Neonatal Med*, 13(4), p.p. 215-222.,
- Leung, W.C., Oepkes, D., Seaward, G. & Ryan, G. (2002) Serial sonographic findings of four fetuses with homozygous alpha-thalassemia-1 from 21 weeks onwards. *Ultrasound Obstet Gynecol*, 19(1), p.p. 56-59.
- Li, J., Chu, X., Liu, Y., Jiang, J.H., He, Z., et al. (2005). A colorimetric method for point mutation detection using high-fidelity DNA ligase. *Nucleic Acids Res*, 33, p. e168.
- Lie-Injo, L & Jo, B.H. (1960) A fast-moving hemoglobin in hydrops foetalis. *Nature*, 185, p. 698.
- Lo, Y.M.D. (2005). Recent Advances in Fetal Nucleic Acids in Maternal Plasma. *Journal of Histochemistry & Cytochemistry*, 53, p.p. 293 - 296.
- Locatelli, F., Rocha, V., Reed, W., Bernaudin, F., Ertem, M., et al. (2003). Related umbilical cord blood transplantation in patients with thalassemia and sickle cell disease. *Blood*, 101, p.p. 2137 - 2143.
- Lorey, F., Cunningham, G., Vichinsky, E.P., Lubin, B.H., Witkowska H.E. et al. (2001). Universal newborn screening for Hb H disease in California. *Genet Test*, 5(2), p.p. 93-100.
- Losekoot, M., Fodde, R., Harteveld, C.L., van Heeren, H., Giordano, P.C., et al. (1990). Denaturing gradient gel electrophoresis and direct sequencing of PCR amplified genomic DNA: a rapid and reliable diagnostic approach to beta thalassaemia. *Br J Haematol*, 76(2), p.p. 269-274.
- Lucarelli, G., Galimberti, M., Polchi, P., Angelucci, E., Baronciani, D., et al. (1990). Bone marrow transplantation in patients with thalassemia. *N Engl J Med*, 322(7), p.p. 417-21.
- Magro, S., Puzzonina, P., Consarino C., et al. (1990). Hypothyroidism in patients with thalassemia syndromes. *Acta Haematol*, 84, p.p.72-76.
- Maiavacca, R., Tedeschi, S., Mosca, A., Calmi, S., De Leonardis, P., et al. (1992). Nonradioactive quantification of low concentrations of hemoglobin A by HPLC for midtrimester prenatal diagnosis of beta-thalassemia. *Clin Chem*, 8, p.p. 1906 - 1908.
- Mario, N, Baudin, B. & Giboudeau, J. (1998). Qualitative and quantitative analysis of hemoglobin variants by capillary isoelectric focusing. *J Chromatogr B Biomed Sci Appl*, 706(1), p.p. 123-129.
- Mathews, C.K. & Holde, K.E.V. (1996). *Biochemistry, The Benjamin/Cummings*. Publishing Company, New York.
- Mavrou, A., Kouvidi, E., Antsaklis, A., Souka, A., Kitsiou Tzeli, S., et al. (2007). Identification of nucleated red blood cells in maternal circulation: a second step in screening for fetal aneuploidies and pregnancy complications. *Prenat Diagn*, 27(2), p.p. 150-153.
- Mazza, P., Giua, R., De Marco, S., Bonetti, M.G., Amurri, B., al et. (1995). Iron overload in thalassemia: comparative analysis of magnetic resonance imaging, serum ferritin and iron content of the liver. *Haematologica*, 80, p.p. 398 - 404.,
- McNiel, J.R. (1968). *The inheritance of hemoglobin H disease* (abstr). XII Congress of the International Society of Hematology, p. 52.
- Meaburn, E, Butcher, L.M., Schalkwyk, L.C. & Plomin, R. (2006). Genotyping pooled DNA using 100K SNP microarrays: a step towards genomewide association scans. *Nucleic Acids Res*, 34, p. e28.
- Medlineplus, Medical Encyclopedia, The US National Library of Medicine and the National Institutes of Health. Available: <http://www.nlm.nih.gov/medlineplus/ency/article/003490.htm> (October 16, 2003).
- Michlitsch, J., Azimi, M., Hoppe, C., Walters, M.C., Lubin, B., et al. (2009). Newborn screening for hemoglobinopathies in California. *Pediatr Blood Cancer*, 52(4), p.p. 486-490.

- Minnich, V., Na-nakorn, S., Chongchareonsuk, S., & Kochaseni, S. (1954). Mediterranean Anemia: A Study of Thirty-two Cases in Thailand. *Blood*, 9, p.p.1 - 23.
- Mundee, Y, Bigelow, N.C., Davis, B.H.& Porter, J.B. (2000). Simplified flow cytometric method for fetal hemoglobin containing red blood cells. *Cytometry*, 42(6), p.p. 389-393.
- Nalbandian, R.M., Nichols, B.M., Camp, Jr. F.R., Lusher, J.M., Conte, N.F., et al. (1971). Dithionite Tube Test-A Rapid, Inexpensive Technique for the Detection of Hemoglobin S and Non-S Sickling Hemoglobin. *Clin Chem*, 17, p.p.1028 - 1032.
- Na-Nakorn, S., Wasi, P., Pornpatkul, M. & Pootrakul, S.N. (1969). Further evidence for a genetic basis of hemoglobin H disease from newborn offspring of patients. *Nature*, 223(5201), p.p. 59-60.
- Nathan, D.G. & Gunn, R.B. (1966). Thalassemia: the consequences of unbalanced hemoglobin synthesis. *Am J Med*, 41(5), p.p. 815-830.
- Nathan, D.G. & Piomelli, S. (1990). Oral iron chelators. *Semin Hematol*, 27(2), p.p. 83-5.
- Nathan, D.G. & Oski, F.A. (1993). *Hematology of infancy and childhood*, 4th ed. Philadelphia: W B Saunders Co.
- Neidlinger, N.A., Larkin, S.K., Bhagat, A., Victorino, G.P. & Kuypers, FA. (2006). Hydrolysis of Phosphatidylserine-exposing Red Blood Cells by Secretory Phospholipase A2 Generates Lysophosphatidic Acid and Results in Vascular Dysfunction. *J. Biol. Chem.*, 281, p.p. 775 - 781.
- New Methylene, Blue MSDS Sheet. Available: <http://www.jtbaker.com/msds/englishhtml/n2700.htm> (April 20, 2003)
- Newton, C.R., Graham, A., Heptinstall, L.E., Powell S.J., Summers, C., et al. (1989). Analysis of any point mutation in DNA. The amplification refractory mutation system (ARMS). *Nucleic Acids Res*, 17, p.p. 2503 - 2516.)
- Old, J., Petrou, M., Varnavides, L., Layton, M., & Modell, B. (2000). Accuracy of prenatal diagnosis for hemoglobin disorders in the UK: 25 years' experience. *Prenat Diagn*, 20(12), p.p. 986-991.
- Olivieri, N.F. & Brittenham, G.M. (1997). Iron-chelating therapy and the treatment of thalassemia. *Blood*, 89, p.p. 739-761.
- Olivieri, N.F. (1999). Correction: The (beta)-Thalassemias. *N Engl J Med* 1999; 341: 99-109 July 8, 1999. *N Engl J Med*, 341(18), p. 1407.
- Orita, M., Iwahana, H., Kanazawa, H., Hayashi, K. & Sekiya, T. (1989). Detection of Polymorphisms of Human DNA by Gel Electrophoresis as Single-Strand Conformation Polymorphisms. *PNAS*, 86, p.p. 2766 - 2770.
- Orkin, S.H. (1978). The duplicated human globin genes lie close together in cellular DNA. *PNAS*, 75, p.p. 5950 - 5954.
- Orkin, S.H., Old, J., Lazarus, H., Altay, C., Gurgey, A., et al. (1979). The molecular basis of alpha-thalassemias: frequent occurrence of dysfunctional alpha loci among non-Asians with Hb H disease. *Cell*, 17(1), p.p. 33-42.
- Orofino, M.G., Argioli, F., Sanna, M.A., Rosatelli, M.C., Tuveri, T., et al. (2003). Fetal HLA typing in beta thalassaemia: implications for haemopoietic stem-cell transplantation. *Lancet*, 362(9377), p.p. 41-42.
- Osterhout, M.L., Ohene-Frempong, K. & Horiuchi, K. (1996). Identification of F-reticulocytes by two-stage fluorescence image cytometry. *J Histochem Cytochem*, 44, p.p. 393 - 397.
- Papadea, C. & Cate, J.C. (1996). Identification and quantification of hemoglobins A, F, S, and C by automated chromatography. *Clin Chem*, 42, p.p. 57 - 63.

- Pembrey, M.E., McWade, P. & Weatherall, D.J. (1972). Reliable routine estimation of small amounts of foetal hemoglobin by alkali denaturation. *J Clin Pathol*, 25, p.p. 738 - 740
- Phillips, 3d J.A., Vik, T.A., Scott, A.F., Young, K.E., Kazazian, Jr H.H., et al. (1980). Unequal crossing-over: a common basis of single alpha-globin genes in Asians and American blacks with hemoglobin-H disease. *Blood*, 55, p.p. 1066 - 1069.
- Pinto, F.O. & Roberts, I. (2008). Cord blood stem cell transplantation for hemoglobinopathies. *Br J Haematol*, 141(3), p.p. 309-324.
- Pippard, M.J., Callender, S.T., Warner, G.T. & Weatherall, D.J. (1979). Iron absorption and loading in beta-thalassaemia intermedia. *Lancet*, 2, p.p. 819-821.
- Pootrakul, P., Kitcharoen, K., Yansukon, P., et al. (1988). The effect of erythroid hyperplasia on iron balance. *Blood*, 71, p.p. 1124-1129.
- Pootrakul, S, Wasi, P, & Na-Nakorn, S. (1967). Hemoglobin Bart's hydrops foetalis in Thailand. *Ann Hum Genet*, 30(4), p.p. 293-311.
- Rao, V.B., Natrajan, P.G., Lulla, C.P. & Bandodkar, S.B. (1997). Rapid mid-trimester prenatal diagnosis of beta-thalassaemia and other hemoglobinopathies using a non-radioactive anion exchange HPLC technique-an Indian experience. *Prenat Diagn*, 17(8), p.p. 725-731.
- Reid, M., Badaloo, A., Forrester, T. & Jahoor, F. (2006). In vivo rates of erythrocyte glutathione synthesis in adults with sickle cell disease. *Am J Physiol Endocrinol Metab*, 291, p.p. E73 - E79.
- Research Organics. Available: <http://www.resorg.com/> (October 17, 2003).
- Rich, S.A., Ziegler, F.D., & Grimley, P.M. (2002). Prevention of homozygous beta thalassemia by carrier screening in pregnancy. *Haema*, 5 (3), p.p. 242-245.
- Rigas, D.A., Koler, R.D., Cummings, G., Duerst, M.L., Malm, D.R., et al. (1961). Decreased Erythrocyte Survival in Hemoglobin H Disease As a Result of the Abnormal Properties of Hemoglobin H: The Benefit of Splenectomy. *Blood*, 18, p.p. 1 - 17.
- Rigas, D.A., Koler, R.D. & Osgood, E.E. (1955). New Hemoglobin Possessing a Higher Electrophoretic Mobility than Normal Adult Hemoglobin. *Science*, 121, p. 372
- Risdon, R.A., Flynn, D.M. & Barry, M. (1973). The relation between liver iron concentration and liver damage in transfusional iron overload in thalassaemia and the effect of chelation therapy. *Gut*, 14, p. 421.
- Rouyer-Fessard, P., Plassa, F., Blouquit, Y., Vidaud, M., Varnavides, L., et al. (1989). Prenatal diagnosis of hemoglobinopathies by ion exchange HPLC of hemoglobins. *Prenat Diagn*, 9(1), p.p. 19-26.
- Saiki, R.K., Chang, C.A., Levenson, C.H., Warren, T.C., Boehm, C.D., et al. (1988). Diagnosis of sickle cell anemia and beta-thalassemia with enzymatically amplified DNA and nonradioactive allele-specific oligonucleotide probes. *N Engl J Med*, 319(9), p.p. 537-541.
- Saiki, R.K., Scharf, S., Faloona, F., Mullis, K.B., Horn, G.T., et al. (1985). Enzymatic amplification of beta-globin genomic sequences and restriction site analysis for diagnosis of sickle cell anemia. *Science*, 230, p.p. 1350 - 1354.
- Saiki, R.K., Bugawan, T.L., Horn, G.T., Mullis, K.B. & Erlich, H.A. (1986). Analysis of enzymatically amplified beta-globin and HLA-DQ alpha DNA with allele-specific oligonucleotide probes. *Nature*, 324(6093), p.p. 163-166.
- Salmon, J.E., Nudel, U., Schiliro, G., Natta, C.L., & Bank, A. (1978). Quantitation of human globin chain synthesis by cellulose acetate electrophoresis. *Anal Biochem*, 91(1), p.p. 146-157.

- Sanguansermisri, T., Thanaratanakorn, P., Steger, H.F., Tongsong, T., Sirivatanapa, P., et al. (2001). Prenatal diagnosis of hemoglobin Bart's hydrops fetalis by HPLC analysis of hemoglobin in fetal blood samples. *Southeast Asian J Trop Med Public Health*, 32(1), p.p. 180-185.
- Sanguansermisri, T., Thanarattanakorn, P., Steger, H.F., Tongsong T, Chanprapaph, P., et al. (2001). Prenatal diagnosis of beta-thalassemia major by high-performance liquid chromatography analysis of hemoglobins in fetal blood samples. *Hemoglobin*, 25(1), p.p. 19-27.
- Schaible, U.E. & Kaufmann, S.H. (2004). Iron and microbial infection. *Nat Rev Microbiol*, 2(12), p.p. 946-53.
- Silvestroni, E. & Bianco, I. (1983). A highly cost effective method of mass screening for thalassaemia. *Br Med J (Clin Res Ed)*, 286, p.p. 1007 - 1009.
- Simsek, M., Daar, S., Ojeli, H. & Bayoumi, R. (1999). Improved diagnosis of sickle cell mutation by a robust amplification refractory polymerase chain reaction. *Clin Biochem*, 32(8), p.p. 677-680.
- Singer, K., Chernoff, A.I. & Singer, L. (1951). Studies on Abnormal Hemoglobins: I. Their Demonstration in Sickle Cell Anemia and Other Hematologic Disorders by Means of Alkali Denaturation. *Blood*, 6, p.p. 413 - 428.,
- Siniscalco, M., Bernini, L., Filippi, G., Latte, B., Khan, M., et al. (1966). Population genetics of hemoglobin variants, thalassaemia and glucose-6-phosphate dehydrogenase deficiency, with particular reference to the malaria hypothesis. *Bull World Health Organ*, 34(3), p.p. 379-393.
- Sirichotiyakul, S., Tantipalakorn, C., Sanguansermisri, T., Wanapirak, C. & Tongsong, T. (2004). Erythrocyte osmotic fragility test for screening of alpha-thalassemia-1 and beta-thalassemia trait in pregnancy. *Int J Gynaecol Obstet*, 86(3), p.p. 347-350.
- Sklar, C.A., Lew, L.Q., Yoon, D.J., David, R. (1987). Adrenal function in thalassemia major following long-term treatment with multiple transfusions and chelation therapy: evidence for dissociation of cortisol and adrenal androgen secretion. *Am J Dis Child*, 141, p.p. 327-330.
- Skoog, D.A. & Leary, J.J. (1992). *Principles of Instrumental Analysis*, Saunders College Publication, New York.
- Skordis, N. (2006). The growing child with thalassaemia. *J Pediatr Endocrinol Metab*, 19(4), p.p. 467-469.
- Srisawang, B., Kongtawelert, P., Hartwell, S.K., Jakmunee, J. & Grudpan, K. (2003). A simple flow injection-reduced volume column system for hemoglobin typing. *Talanta*, 60(6), p.p. 1163-1170.
- Stohs, S.J. & Bagchi, D. (1995). Oxidative mechanisms in the toxicity of metal ions. *Free Radic Biol Med*, 18(2), p.p. 321-336.
- Suwanrath-Kengpol, C., Kor-anantakul, O., Suntharasaj, T. & Leetanaporn, R. (2005). Etiology and outcome of non-immune hydrops fetalis in southern Thailand. *Gynecol Obstet Invest*, 59(3), p.p. 134-137.
- Svensson, H. (1962). Isoelectric fractionation, analysis and characterization of ampholytes in natural pH gradients. III, Description of apparatus for electrophoresis in columns stabilized by density gradients and direct determination of isoelectric points. *Arch Biochem*, Suppl.I, p. 132.
- Tai, D.Y.H., Wang, Y.T., Lou, J., Wang, W.Y., Mak KH., et al. (1996). Lungs in thalassaemia major patients receiving regular transfusion. *Eur Respir J*, 9, p.p. 1389-1394.

- Takahashi-Fujii, A., Ishino, Y., Kato, I. & Fukumaki, Y. (1994). Rapid and practical detection of beta-globin mutations causing beta-thalassemia by fluorescence-based PCR-single-stranded conformation polymorphism analysis. *Mol Cell Probes*, 8(5), p.p. 385-393.
- Takatsu, K., Yokomaku, T., Kurata, S. & Kanagawa, T. (2004). A new approach to SNP genotyping with fluorescently labeled mononucleotides. *Nucleic Acids Res*, 32, p. e60.
- Tangvarasittichai, O., Jongjitwimol, J. & Tangvarasittichai, S. (2008). Whatman 3 MM dried blood spots for identifying alpha-thalassemia-1. *Clin Lab*, 54(7-8), p.p. 281-283.
- Tangvarasittichai, O., Jeenapongsa, R., Sitthiworanan, C. & Sanguansermisri, T. (2004). Diagnostic value of combined parameters for  $\alpha$ -thalassemia 1 screening in pregnant women. *Naresuan University Journal*, 12, p.p. 19-24.
- Tangvarasittichai, S., Tangvarasittichai, O. & Jermnim, N. (2009). Comparison of fast protein liquid chromatography (FPLC) with HPLC, electrophoresis & microcolumn chromatography techniques for the diagnosis of  $\alpha$ -thalassemia. *Indian J Med Res*, 129, p.p. 242-248
- Tanner, M.A., He, T., Westwood, M.A., Firmin, D.N., Pennell, D.J. & Thalassemia International Federation Heart T2\* Investigators. (2006). Multi-center validation of the transferability of the magnetic resonance T2\* technique for the quantification of tissue iron. *Haematologica*, 91, p.p. 1388 - 1391.
- Telfer, P.T., Prestcott, E., Holden, S., Walker, M., Hoffbrand A.V., et al. (2000). Hepatic iron concentration combined with long-term monitoring of serum ferritin to predict complications of iron overload in thalassaemia major. *Br J Haematol*, 110(4), 971-977.
- Thakerngpol, K., Fucharoen, S., Boonyaphipat, P., et al. (1996). Liver injury due to iron overload in thalassemia: histopathologic and ultrastructural studies. *Biometals*, 9, p.p. 177-183.
- Thalassemia International Federation. (2008). Guidelines for the clinical management of thalassemia 2nd edition. [<http://www.thalassemia.org.cy>]
- Thomas, E.D., Buckner, C.D., Sanders, J.E., Papayannopoulou, T., Borgna-Pignatti, C., et al. (1982). Marrow transplantation for thalassaemia. *Lancet*, 2(8292), p.p. 227-229.
- Ueda, S. & Schneider, R.G. (1969). Rapid identification of polypeptide chains of hemoglobin by cellulose acetate electrophoresis of hemolysates. *Blood*, 34, p. 230.
- Ui, N. (1971). Isoelectric points and conformation of proteins. I. Effect of urea on the behavior of some proteins in isoelectric focusing. *Biochim Biophys Acta*, 229, p.567.
- van Weeghel, R., Steunebrink, G. & Suk, R., (2000). Proceedings of the International Society for Analytical Cytology ISAC2000 International Congress, Poster abstract No. 6730, May 19-35, Presented by Purdue University Cytometry Laboratories, Available: <http://www.wiley.com/legacy/products/subject/life/cytometry/isac2000/6730.htm>.
- Villeneuve, J.P., Bilodeau, M., Lepage, R., Cote, J. & Lefebvre, M. (1996). Variability in hepatic iron concentration measurement from needle-biopsy specimens. *J Hepatol*, 25(2): 172-177.
- Vrettou, C., Palmer, G., Kanavakis, E., Tzetis, M., Antoniadis, T., et al. (1999). A widely applicable strategy for single cell genotyping of beta-thalassaemia mutations using DGGE analysis: application to preimplantation genetic diagnosis. *Prenat Diagn*, 19(13): 1209-1216.
- Weatherall, D.J. (1987). Common genetic disorders of the red cell and the malaria hypothesis. *Ann Trop Med Parasitol*, 81(5), p.p. 539-548.
- Weatherall, D.J. (1994). *The thalasseмии*. In: Stamatoyannopoulos, G., Nienhuis, A.W., Majerus, P.H., Varmus, H. eds. *The molecular basis of blood diseases*. 2nd ed. Philadelphia: W.B. Saunders, p.p. 157-205.

- Weatherall, D.J. (1997). Fortnightly review: The thalassaemias *BMJ*, 314, p. 1675.
- Weatherall, D.J. (1998). Thalassaemia in the next millennium. *Ann N Y Acad Sci*, 850, p.p. 1-9.
- Weatherall, D.J. (2008). Hemoglobinopathies worldwide: present and future. *Curr Mol Med*, 8(7), p.p. 592-599.
- Weatherall, D.J. & Clegg, J.B. (1981). *The Thalassaemia Syndromes*, 3rd edn. Oxford: Blackwell
- Weatherall, D.J. & Clegg, J.B., (2001). *The Thalassaemia Syndromes*, 4th ed., Blackwell Science, USA, ,
- Weatherall, D.J. & Clegg, J.B. (2001). *The  $\beta$  and  $\delta\beta$  thalassaemia association with structural hemoglobin variants*. In: Weatherall DJ, Clegg JB. Eds. *The Thalassaemia syndromes*. 4th ed. Oxford, UK: Blackwell scientific Publications, p.p.393-449.
- Westgren, M., Ringden, O., Eik-Nes, S., Ek, S., Anvret, M., et al. (1996). Lack of evidence of permanent engraftment after in utero fetal stem cell transplantation in congenital hemoglobinopathies. *Transplantation*, 61(8), p.p. 1176-1179.
- Wilson, J.B., Headlee, M.E., & Huisman, T.H. (1983). A new high-performance liquid chromatographic procedure for the separation and quantitation of various hemoglobin variants in adults and newborn babies. *J Lab Clin Med*, 102(2), p.p. 174-86.
- Winichagoon, P., Thitivichianlert, A., Lebnak, T., Piankijagum, A. & Fucharoen, S. (2002). Screening for the carriers of thalassaemias and abnormal hemoglobins at the community level. *Southeast Asian J Trop Med Public Health*, 33 Suppl 2,p.p. 145-150.
- Witzleben, C.L. & Wyatt, J.P. (1961). The effect of long survival on the pathology of thalassaemia major. *J Pathol Bacteriol*, 82, p.p.1-12.
- Wolfe, L., Olivieri, N., Sallan, D, et al. (1985). Prevention of cardiac disease by subcutaneous deferoxamine in patients with thalassaemia major. *N Engl J Med*, 312, p.p. 1600-1603.
- Wong, K.K., Tsang, Y.T.M., Shen, J., Cheng, R.S., Chang, Y.M., et al. (2004). Allelic imbalance analysis by high-density single-nucleotide polymorphic allele (SNP) array with whole genome amplified DNA. *Nucleic Acids Res*, 32, p. e69.
- Wood, K.C., Hsu, L.L. & Gladwin, M.T. (2008). Sickle cell disease vasculopathy: a state of nitric oxide resistance. *Free Radic Biol Med*, 44(8), p.p. 1506-1528.
- Wood, J.C., Tyszka, J.M., Carson, S., Nelson, M.D. & Coates, T.D. (2004). Myocardial iron loading in transfusion-dependent thalassaemia and sickle cell disease. *Blood*, 103, p.p. 1934 - 1936.
- Wu, K.H., Tsai, F.J. & Peng, C.T. (2003). Growth hormone (GH) deficiency in patients with beta-thalassaemia major and the efficacy of recombinant GH treatment. *Ann Hematol*, 82(10), p.p. 637-640.
- Yang, Y. & Li, D.Z. (2009). A survey of pregnancies with Hb Bart's disease in Mainland China. *Hemoglobin*, 33(2), p.p. 132-136.
- Yuregir G.T. (1976). Determination of fetal hemoglobin in various age groups by the immunological method of Kohn and Payne. *Clin Chim Acta*, 72(2), p.p. 181-185.
- Zurlo, M.G., De Stefano, P., Borgna-Pignatti, C., Di Palma, A., Piga, A., et al. (1989). Survival and causes of death in thalassaemia major. *Lancet*, 2(8653), p.p. 27-30.



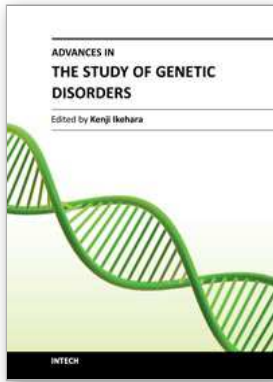

## **Advances in the Study of Genetic Disorders**

Edited by Dr. Kenji Ikehara

ISBN 978-953-307-305-7

Hard cover, 472 pages

**Publisher** InTech

**Published online** 21, November, 2011

**Published in print edition** November, 2011

The studies on genetic disorders have been rapidly advancing in recent years as to be able to understand the reasons why genetic disorders are caused. The first Section of this volume provides readers with background and several methodologies for understanding genetic disorders. Genetic defects, diagnoses and treatments of the respective unifactorial and multifactorial genetic disorders are reviewed in the second and third Sections. Certainly, it is quite difficult or almost impossible to cure a genetic disorder fundamentally at the present time. However, our knowledge of genetic functions has rapidly accumulated since the double-stranded structure of DNA was discovered by Watson and Crick in 1956. Therefore, nowadays it is possible to understand the reasons why genetic disorders are caused. It is probable that the knowledge of genetic disorders described in this book will lead to the discovery of an epoch of new medical treatment and relieve human beings from the genetic disorders of the future.

### **How to reference**

In order to correctly reference this scholarly work, feel free to copy and paste the following:

Tangvarasittichai Surapon (2011). Thalassemia Syndrome, *Advances in the Study of Genetic Disorders*, Dr. Kenji Ikehara (Ed.), ISBN: 978-953-307-305-7, InTech, Available from:  
<http://www.intechopen.com/books/advances-in-the-study-of-genetic-disorders/thalassemia-syndrome>

# **INTECH**

open science | open minds

### **InTech Europe**

University Campus STeP Ri  
Slavka Krautzeka 83/A  
51000 Rijeka, Croatia  
Phone: +385 (51) 770 447  
Fax: +385 (51) 686 166  
[www.intechopen.com](http://www.intechopen.com)

### **InTech China**

Unit 405, Office Block, Hotel Equatorial Shanghai  
No.65, Yan An Road (West), Shanghai, 200040, China  
中国上海市延安西路65号上海国际贵都大饭店办公楼405单元  
Phone: +86-21-62489820  
Fax: +86-21-62489821

© 2011 The Author(s). Licensee IntechOpen. This is an open access article distributed under the terms of the [Creative Commons Attribution 3.0 License](#), which permits unrestricted use, distribution, and reproduction in any medium, provided the original work is properly cited.