

# Spray Cooling

Zhibin Yan<sup>1</sup>, Rui Zhao<sup>1</sup>, Fei Duan<sup>1</sup>, Teck Neng Wong<sup>1</sup>, Kok Chuan Toh<sup>2</sup>,  
Kok Fah Choo<sup>2</sup>, Poh Keong Chan<sup>3</sup> and Yong Sheng Chua<sup>3</sup>

<sup>1</sup>*School of Mechanical and Aerospace Engineering, Nanyang Technological University,*

<sup>2</sup>*Temasek Laboratories @ NTU,*

<sup>3</sup>*DSO National Laboratories  
Singapore*

## 1. Introduction

### 1.1 Categorisation of cooling techniques

The need for higher heat flux cooling techniques is driven very much by the microelectronics and semiconductor industry. In accordance with Moore's Law, continuing advances in the semiconductor industry allow the device feature size to shrink and the transistor density and switching speed to double every one and a half to two years. Correspondingly, the heat dissipation from the chip increases in proportion, if there is no change in the semiconductor technology. In their study on the limits of device scaling and switching speeds, Zhirnov et al. (2003) concluded that "even if entirely different electron transport models are invented for digital logic, their scaling for density and performance may not go much beyond the ultimate limits obtainable with CMOS technology, due primarily to limits on heat removal capacity". For example, maximum heat flux at the localized submillimeter scale hotspots of high performance chips approaches 1 kW/cm<sup>2</sup> (Bar-Cohen et al., 2006). The operating efficiencies and stability of these devices depend on how effectively the heat generated can be removed from the system. Hence, developments in the cooling system have to keep pace with the heat removal requirements, starting with forced air convection being enhanced by compact finned heat sinks, to liquid-cooled microchannel arrays, and ultimately using phase change heat transfer through the boiling phenomena or from atomized sprays and jets. The choice of an appropriate cooling technique is however dependent on the specific application and the critical system factors which must be satisfied, such as the maximum permissible heat flux, total heat load, tight temperature tolerances, reliability considerations or overall power consumption. The operating environment also play a significant part which may necessitate an emphasis on the use of space, complexity of the system's components, relative maturity of the technology or cost.

Table 1 shows comparative cooling technologies and the respective heat fluxes and heat transfer coefficients (Glassman, 2005). There may be other work that list values outside of this table, but the nominal capacities of these cooling technologies in the table can still be viewed as a good reference. In general, cooling methods using sub-cooled flow boiling (SCFB), micro-channel cooling, two-phase jet impingement and spray cooling have achieved very high heat fluxes (over 100 W/cm<sup>2</sup>) and heat transfer coefficients compared

to the other traditional cooling techniques. However, under the right combination of factors, spray cooling has been found to be preferred over the other high heat flux cooling techniques.

Mechanism	Cooling Method	Heat Transfer Coefficient (W/cm <sup>2</sup> .K)	Highest Heat Flux (W/cm <sup>2</sup> )	Reference
Single Phase	Free Air Convection	0.0005-0.0025	15	(Mudawar, 2001; Azar, 2002)
Single Phase	Forced Air Convection, (Heat Sink with a fan)	0.001-0.025	35	(Mudawar, 2001)
Single Phase	Natural Convection with FC	0.1	0.1-3	(Anderson et al., 1989)
Single Phase	Natural Convection with water	0.08-0.2	5-90	(Mudawar, 2001)
Two Phase	Heat Pipes (water)	-NA-	250	(Zuo et al., 2001)
Single Phase	Micro-channel	-NA-	790	(Tukerman et al., 1981)
Electrical	Peltier Cooler	-NA-	125	(Riffat et al., 2004)
Two phase	Pool boiling with porous media	3.7	140	(Rainey et al., 2003a )
Two Phase	Sub-cooled Flow Boiling	2	129	(Sturgis and Mudawar, 1999)
Two Phase	Micro-channel Boiling	10-20	275	(Faulkner et al., 2003)
Two Phase	Spray Cooling	20-40	1200	(Pais et al., 1992)
Two Phase	Jet Impingement	28	1820	(Overholt et al., 2005)

Table 1. Cooling Techniques and Respective Heat Fluxes and Heat Transfer Coefficients (Glassman, 2005)

## 1.2 Major application areas of spray cooling

Spray cooling utilises a spray of small droplets impinging on a heated surface to increase the effectiveness of heat transfer as a cooling mechanism with phase change (Incropera and Dewitt, 2002). Spray cooling is widely used in various fields: fire protection, cooling of hot gases, dermatological operation and cooling of hot surfaces including hot strip mill and high performance electronic devices.

A fire sprinkler system is a common application of spray cooling for fire protection. A discharge of water through the nozzles into the ambient is atomized into tiny droplets in order to control or suppress the fire. The large surface area of the small droplets in contact with unsaturated ambient air promotes evaporation. As a result of the high latent heat

absorbed by the water drops during evaporation, the heat release rate of the fire can be controlled to prevent fire spread.

In the metal production and processing industry, spray cooling also plays an important role for the high temperature (up to 1800 K) steel strip casting and the final microstructure optimization after hot rolling. Typically, a jet of gas carrying water drops is sprayed towards the hot surface to be cooled. Figure 1 shows a boiling curve corresponding to a certain water impact density in this process.

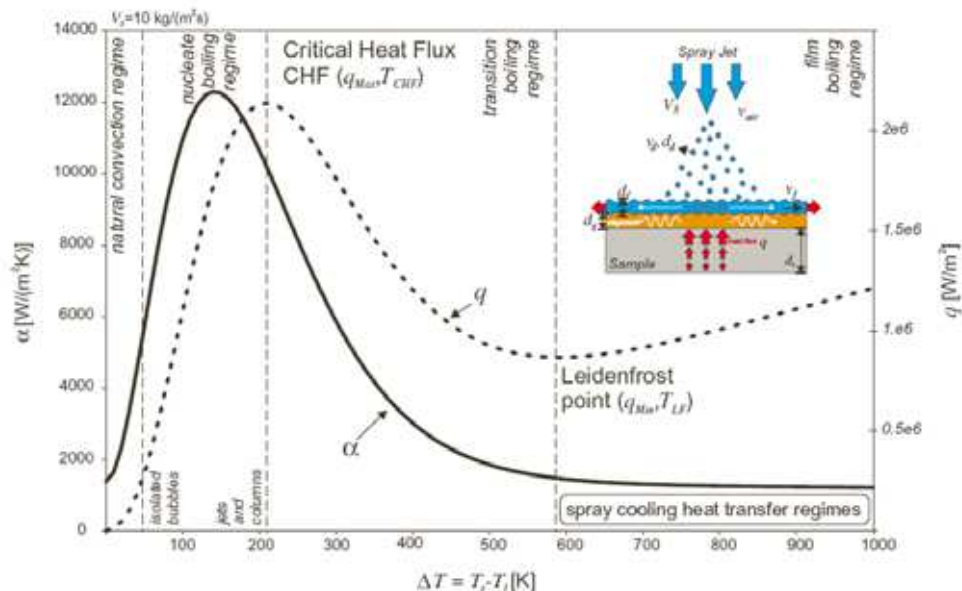

Fig. 1. Typical boiling curve in metal production (Wendelstorf et al., 2008)

In the biomedical industry, cryogenic spray cooling is implemented for selectively precooling of human skin during laser treatment with port wine stain birthmarks and hair removal. To avoid the permanent thermal damage to the skin surface arising from large temperature differences between the epidermis and deeper targeted vessels, a cryogenic spray can be spurted to the skin surface for a short period of time before the laser pulse is applied. Figure 2 shows a cryogenic spray using R134a as a working fluid for contact cooling of human skin.

However, this chapter will be devoted primarily to the study of cooling hot surfaces in high performance electronic devices. In the electronic packaging industry, spray cooling has drawn great attention due to its high heat flux removal ability (1200 W/cm<sup>2</sup>) while maintaining device temperature below 100 °C with spatial and temporal variations below 10 °C (Pais et al., 1992; Bar-Cohen et al., 2006). Currently, spray cooling have been used in a high performance computer (CRAY X-1) and is a promising solution for the thermal management of a high power insulated gate bipolar transistor (Mertens et al., 2007), laser diode laser arrays (Huddel et al., 2000) and microwave source components (Lin et al., 2004). Two examples of such applications are given in Figure 3 developed by Bar-Cohen et al. (1995) and Tilton et al. (1994).

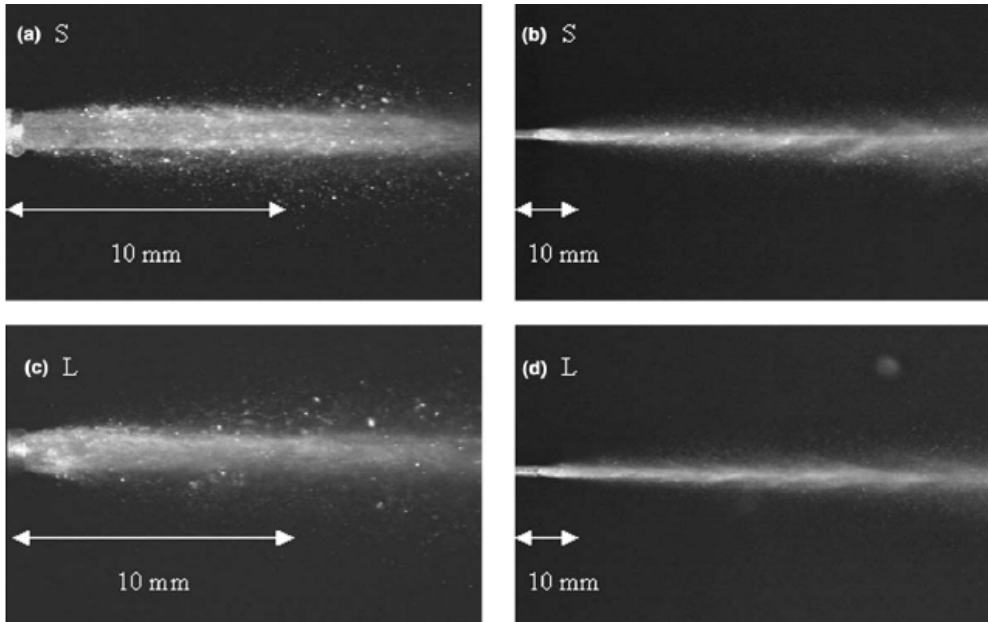

Fig. 2. Images of cryogen sprays for human skins (Aguilar et al., 2001)

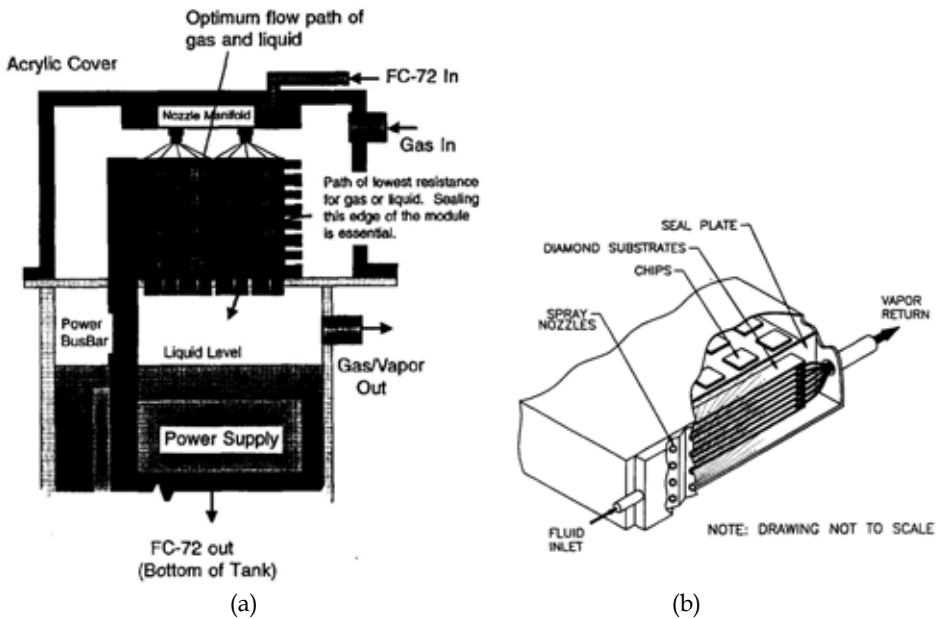

Fig. 3. Spray cooling system for electronic devices by (a) Bar-Cohen et al. (1995); (b) Tilton et al. (1994)

## 2. Heat transfer mechanisms and critical heat flux in spray cooling

The heat transfer mechanisms occurring in a spray cooling process have yet to be clearly established, although it is known that spray cooling may comprise several heat transfer mechanisms that contribute to its high heat removal rate (Rini, 2000; Sellers, 2000; Tan, 2001; Selvam, 2006). The combination and interference of these mechanisms makes spray cooling unique compared to other conventional cooling methods such as forced convection which makes use of only a single phase fluid to achieve its cooling purposes.

Four major heat transfer mechanisms were proposed by Pais et al., 1992; Mesler and Mailen, 1993; Yang et al., 1996 and Rini et al., 2002. They are (1) evaporation off surface of the liquid film, (2) forced convection arising from droplet impingement on heated surface, (3) enhancement of nucleation sites on heated surface, and lastly (4) presence of secondary nucleation sites on the surface of spray droplets. Figure 4 illustrates the basic heat transfer mechanisms which will be explained in further detail later in this section. Other researchers suggested alternative mechanisms are at work. Selvam et al. (2005, 2006, 2009) proposed that transient conduction accompanying liquid backfilling the superheated heated surface after bubble departure dominated the high heat transfer in spray cooling according to their 2-D numerical simulation. By correlating the heat transfer data with the contact line lengths, Horacek et al. (2004, 2005) suggested that the contact line heat transfer was crucial for spray cooling.

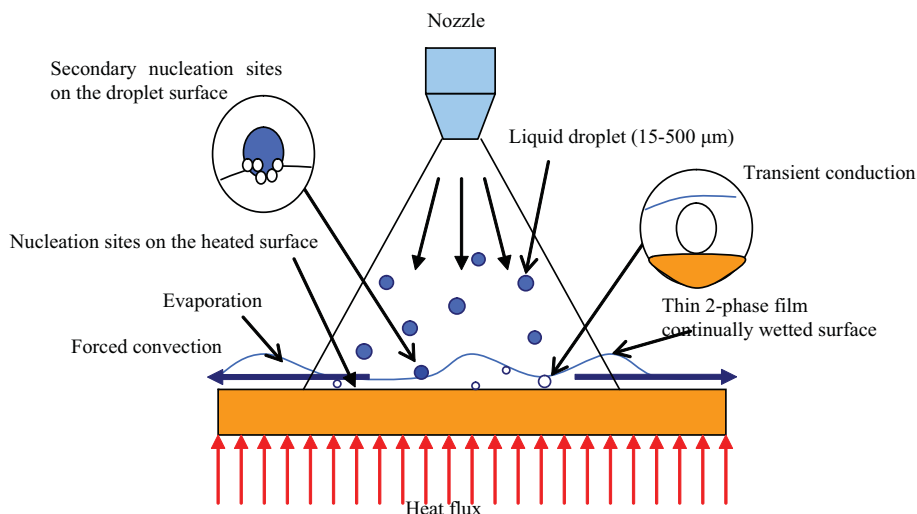

Fig. 4. The heat transfer mechanisms of spray cooling

### 2.1 Major mechanisms in spray cooling

#### 2.1.1 Evaporation off surface of liquid film

Evaporation of liquid molecules from the surface of liquid film is one of the key factors in the heat transfer mechanism of spray cooling. As shown in Figure 5, a film of liquid is formed over the heated surface when spray cooling is initiated. This film is usually very thin

at only a few hundred microns (300-500  $\mu\text{m}$ ). The impingement of spray droplets can generate an additional mixing, which decreases the already small effective thermal resistance resulting from the thin film of liquid, and improves the overall heat transfer efficiency considerably. Pais et al. (1992) suggested that evaporation from thin film is the dominant heat transfer mechanism in spray cooling according to their experimental studies on ultrasmooth surfaces. Although the phase change portion of evaporation process was also proposed as a possible enhancement for heat transfer, it is not considered to be the dominant effect (Silk et al., 2008). Silk et al. concluded that spray cooling with moderate evaporation efficiency can reach a higher heat flux compared with spray cooling process with full evaporation of the liquid on the heated surface, based on most experimental investigations they have reviewed.

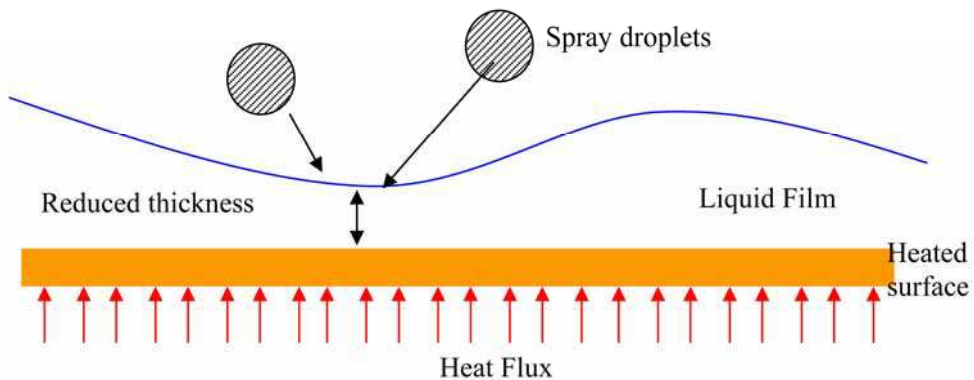

Fig. 5. Reduced thermal resistance due to impingement of droplet

### 2.1.2 Forced convection by droplet impingement

When the droplets impinge on the thin liquid film, the force from the incoming droplets produce an enhancement of the forced convection in the liquid film as illustrated in Figure 6. This has been proven to be a very important factor in previous works (Tan, 2001) on spray cooling with water. A cooling rate as high as 200  $\text{W}/\text{cm}^2$  and with a surface temperature of 99°C has been observed using water as a working fluid (Nevedo, 2000). Since nucleation is absent at the surface temperature of 99 °C, the majority of the heat flux removed has been credited to the forced convection by the droplet impingement for the single phase spray cooling. In the two phase region, the forced convection by droplet impingement is proposed to have the dominant effect at the period of low heat flux and surface superheat. Pautsch and Shedd (2005) and Shedd and Pautsch (2005) conducted a series of spray cooling experiments with single and multiple nozzles and developed an empirical model based on their experimental results. With the aid of visualisation studies, their model indicated that single-phase energy transfer by bulk fluid momentum played the major role in the high heat flux spray cooling, where a thin liquid film had formed on the heated surface.

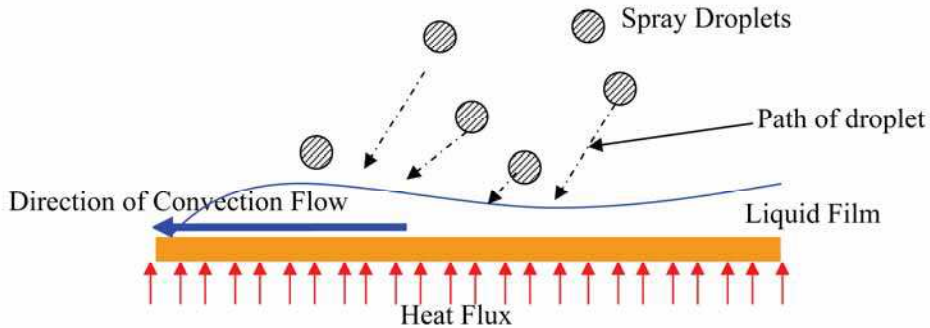

Fig. 6. Schematic of forced convection under droplet impingement

### 2.1.3 Fixed nucleation sites on heated surface

From previous experiments done on spray cooling, bubbles appear to be growing from fixed nucleation sites on the heated surface. This is possibly due to cavitations on the heated surface that promotes the growth of bubbles (Rini, 2000). The initiation of bubble growth is due to the absorbed heat flux and the temperature of the local nucleus site reaching  $T_{sat}$  which results in phase change of the liquid. When this happens, the bubble starts to grow from the nucleus by absorbing the heat from the heated surface and the surface temperature drops. It is also noted that bubbles would not start to grow around an existing nucleation site, probably a result of the existing bubble taking the required heat away from the surrounding surface necessary for another bubble initiation (Carey, 1992; Rohsenow et al., 1998).

In pool boiling, the bubble requires a period of time to gain enough buoyancy force at a certain diameter to overcome the surface tension of liquid and gravity for departure, and the nucleation sites also need time to recover the heat loss and increase in temperature to  $T_{sat}$  before a second bubble can be initiated from the same site. However in spray cooling, the momentum available in a droplet enables it to impinge through the liquid film and hit on the heated surface frequently, resulting in the break up of bubbles on the nucleation sites. This causes rapid removal of bubbles at the nucleation sites and a shorter interval time for bubble growth from the same site. Another possible scenario is when the forced convection by the droplet impingement discussed previously clears the bubbles from the surface, resulting in increase of new bubbles nucleating from the sites and reduction of the duration of bubbles anchoring on the heated surface.

These characteristics of spray cooling allow more bubbles to grow on the surface as the 'reduced bubble' sizes allow for more bubbles to grow around the sites and at a more rapid rate as shown in Figure 7. Previous studies (Pais et al., 1992; Sehmbeiy et al., 1990; Yang et al., 1993; Mudawar et al., 1996; Chen et al., 2002; Hsieh et al., 2004) have shown that the heat transfer in spray cooling is almost an order of magnitude higher than pool boiling (Nishikawa et al., 1967; Mesler et al., 1977; Marto et al., 1977; Hsieh et al., 1999). Though, both cooling methods involve phase change processes, the additional mechanisms and factors present in spray cooling make it favourable for evaporation to take place and make full use of latent heat to cool the heat source.

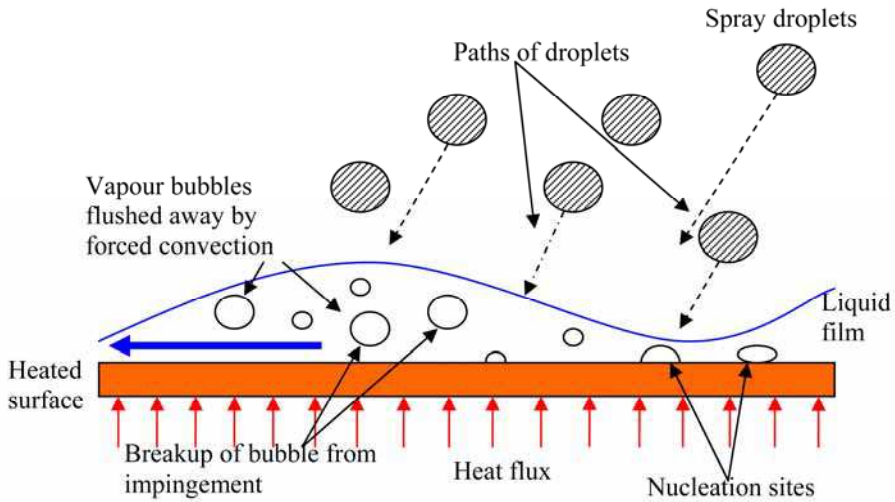

Fig. 7. Schematic of nucleation sites on heated surface under effect of droplets impingement

#### 2.1.4 Secondary nucleation by spray droplets

It was proposed that the large number of secondary nucleation sites entrained by spray droplets is a major reason for spray cooling to remove a higher heat flux from the heated surface than by pool boiling (Rini et al., 2002). Esmailizadeh et al. (1986) and Sigler et al. (1990) both found that the upper surface of a bubble broke into small droplets and fell back to the liquid film when the bubbles impacted the liquid film in pool boiling studies. Thereafter, these small droplets could entrap vapour around them and bring it into the liquid film. Finally, the small vapour bubbles possibly acted as nuclei when they moved close to the heated surface and promoted boiling heat transfer as a result. In spray cooling, a similar phenomenon that the bubbles burst over the liquid film was observed as well. Nevertheless, spray droplets mixed with the vapour around and entrapped vapour bubbles within them. And when the droplets hit the liquid film, the entrapped vapour bubbles act as secondary nuclei sites to grow new bubbles. Hence, spray cooling can produce a lot more bubbles than pool boiling, over 3 to 4 times more (Rini et al., 2002). These additional nuclei sites are very important in the heat transfer mechanism of spray cooling as it provides a lot more nucleation sites for bubbles to grow and to absorb heat from the heated surface.

#### 2.1.5 Transient conduction with liquid backfilling

Transient conduction accompanying liquid backfilling the superheated surface after bubble departure was numerically simulated by Selvam et al. (2006, 2009) using the direct numerical simulation method. Their model suggested that the cold-droplet impingement during impact, rebound of cold liquid after impact and transient conduction attributed to spreading of cold liquid over the dry hot surface played the dominant role in high heat flux spray cooling mechanism. It differs from the widely accepted dominant mechanism which is micro-layer evaporation in saturated pool boiling.

Although there has been no experimental result to support the view that transient conduction is the dominant mechanism in the spray cooling, previous experimental



investigations in pool boiling (Demiray et al., 2004) has provided the evidence that transient conduction enhanced the heat transfer of pool boiling. According to the definition of the transient heat flux through conduction in a semi-infinite region with constant surface temperature as Eq. (1) (Incropera et al., 2002), the transient heat flux in the liquid film of spray cooling is determined by the frequency of vapour bubble departure and liquid around bubble flow over the locations occupied by vapour bubble antecedently.

$$\dot{q}'' = \frac{k(T_{\text{surface}} - T_i)}{\sqrt{\pi\alpha t}} \quad (1)$$

### 2.1.6 Contact line heat transfer

It was proposed by Horacek et al. (2004, 2005) that contact line heat transfer was responsible for the two-phase heat transfer of spray cooling based on their measurements for contact line lengths using total internal reflectance technique (TIR). Their measurement results indicated that the heat flux removal did not depend on the wetted surface area fraction of liquid, but well correlated with the contact line length. It was suggested that the heat flux removal could be improved by controlling the contact line length or the position of the contact line through constructing the surface geometry.

### 2.2 Critical heat flux of spray cooling

Any two phase cooling technology, including spray cooling, is limited by a condition called critical heat flux (CHF), which is defined as the maximal heat flux in the boiling heat transfer, as shown in Figure 8. The most serious problem is that the boiling limitation can be directly related to the physical burnout of the materials of a heated surface due to the suddenly inefficient heat transfer through a vapour film formed across the surface resulting from the replacement of liquid by vapour adjacent to the heated surface.

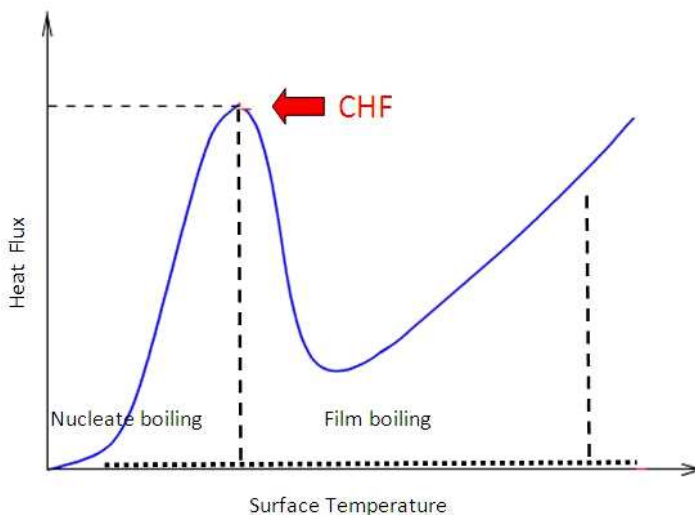

Fig. 8. A typical boiling curve

**2.2.1 Theoretical model**

Correct CHF estimation requires a clear understanding of the physical phenomenon that triggers the CHF, which remains poorly studied, however. By definition, CHF is the watershed of the nucleate boiling and the film boiling. From the perspective of physical phenomena, the most essential and iconic feature of CHF is the formation of the vapour film in the bulk of the liquid. Following this feature, two possible mechanisms are assumed to be responsible to trigger CHF, the coalescence of bubbles in the film, and the liftoff of the thin liquid layer by the vaporization in the film.

The coalescence of bubble is triggered by the merging of a large amount of homogeneous nucleation bubbles. To activate the growth of homogeneous bubbles, the temperature of the heated surface is required to a certain level, so that homogeneous bubbles absorb enough heat to overcome the critical free energy. A classical theory which gained acceptance is the self-consistent theory (SCT) of nucleation (Girshick et al. 1990). Assuming that the homogeneous bubble is spherical, the critical free energy of the homogeneous bubble is presented as:

$$\Delta G = (4\pi r^2 - A)\sigma - (n - 1)k_B T \ln S \tag{2}$$

where  $\Delta G$  is the critical free energy,  $k_B$  the Boltzmann constant,  $S$  the supersaturation, and  $A$  the surface area of a homogeneous nucleus. Under this theory, the nucleation rate becomes

$$I_{set} = \frac{\exp(\sigma / k_B T)}{S} I \tag{3}$$

where  $I$  is the rate calculated from the classical nucleation theory. The exponential coefficient in the equation takes into account the surface energy of the homogeneous nucleus.

The liftoff mechanism were proposed based on the observation that at conditions just prior to CHF, as shown in Figure 9. Below CHF, vapour bubbles on the surface are separated by the liquid sub-layer. When CHF occurs, the liquid sub-layer among vapour bubbles lifts off from the heated surface, so that the heat conduction between the surface and the liquid sub-layer is cut off, resulting in the sudden drop of the heat transfer rate. This phenomenon was then idealized as a wavy liquid-vapour interface depicted in Figure 10, by assuming the vapour to be periodic, wave-like distributed along the heated surface.

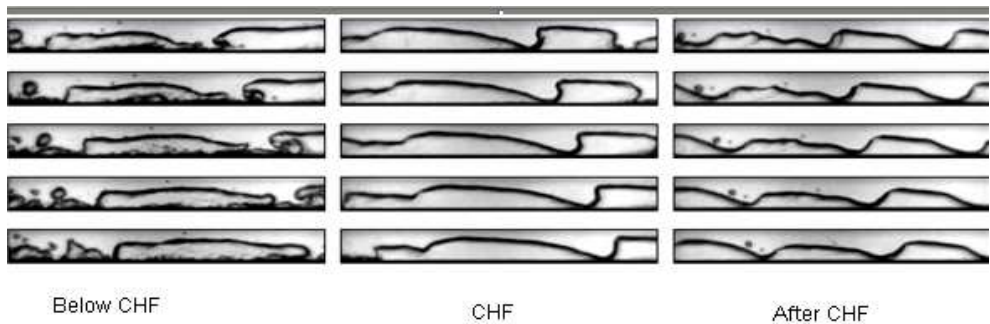

Fig. 9. Images of the liftoff process (Zhang et al., 2005)

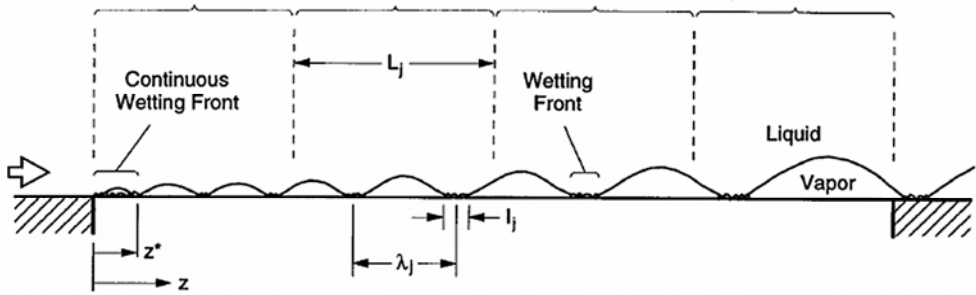

Fig. 10. Idealized periodical, wavelike distribution of vapour on the surface (Sturgis and Mudawar, 1999)

The model for predicting CHF based on this idealization was usually evolved from separated flow model, with the use of the instability analysis, and energy balance analysis, which was well introduced by Sturgis and Mudawar (1999). In the separated flow model, the phase velocity difference caused by the density disparity is responsible for the instability in the boiling. The instability analysis is used to calculate the critical wavelength (the wavelength at which CHF occurs), with the facilitation of energy balance analysis for obtaining the number of wetting fronts.

$$q_{CHF}'' = \frac{l_j}{\lambda_j} \rho_v (C_{p,l} \Delta T + h_{fg}) \left( \frac{p_l - p_v}{\rho_v} \right)^{1/2} l_j (z^*) \tag{4}$$

where  $l_j$  is the wetting front length,  $\lambda_j$  the vapour wave length,  $p_l - p_v$  the average pressure jump across the interface.

**2.2.2 Empirical model**

In spray cooling, empirical models have been developed with the continuous expansion of experimental data bases and applicable systems of interests.

Mudawar and Estes (1996) first attempted an empirical model to predict CHF in spray cooling by correlating CHF with the volumetric flux of liquid and the Sauter Mean Diameter of droplets, as following:

$$\frac{q_{CHF}''}{\rho_v h_{fg} V''} = 1.467 [(1 + \cos(\theta / 2)) \cos(\theta / 2)]^{0.3} \cdot \left( \frac{\rho_l}{\rho_v} \right)^{0.3} \left( \frac{\rho_l \overline{V}^2 d_{32}}{\sigma} \right)^{-0.35} \left[ 1 + 0.0019 \frac{C_{p,l} \Delta T}{\rho_v h_{fg}} \right] \tag{5}$$

where  $\theta$  is the spray cone angle,  $d_{32}$  the Sauter Mean Diameter,  $\sigma$  the surface tension,  $\Delta T$  the superheat temperature,  $h_{fg}$  the evaporative latent heat. To predict CHF using Eq. (5), the nozzle parameters and droplet parameters (pressure drop across the nozzle, volumetric flow rate, inclined angle, and the Sauter Mean Diameter of droplets) have to be tested. In addition, the distance between the nozzle orifice and the surface needs to be chosen carefully, so that the spray cone exactly covers the heated surface. This model was validated by a set of experiments of the spray cooling on a rectangular 1.27×1.27 cm<sup>2</sup> flat surface using refrigerants (FC-72, and FC-87). The volumetric flow rate was regulated inside the range of 16.6 - 216 m<sup>3</sup>.s<sup>-1</sup>.m<sup>-2</sup>. The Sauter Mean Diameter of droplets was inside the range of 110 - 195

µm. The superheat temperature was below 33 °C. The accuracy of this model was claimed to be within ±30%.

Visaria and Mudawar (2008) improved their previous empirical model by adding the effect of inclined spray. They concluded that CHF will decrease by increasing the inclination angle due to the elliptical cone produced by inclined spray decreased both the volumetric flux and spray impact area. An modified correlation was presented as:

$$\frac{q_{CHF}^n}{\rho_v h_{fg} V^n} = 1.467[(1 + \cos(\theta/2))\cos(\theta/2)]^{0.3} \quad (6)$$

$$\cdot \left(\frac{\rho_l}{\rho_v}\right)^{0.3} \left(\frac{\rho_l \overline{V}^2 d_{32}}{\sigma}\right)^{-0.35} \left[1 + 0.0019 \frac{C_{p,l} \Delta T}{\rho_v h_{fg}}\right] \left(\frac{f_1^{0.3}}{f_2}\right)$$

$$f_1 = \frac{Q^n}{Q} \quad (7)$$

$$f_2 = \frac{1}{\left[\frac{\pi}{4} \cos \alpha \sqrt{1 - \tan^2 \alpha \tan^2 \left(\frac{\theta}{2}\right)}\right]} \quad (8)$$

Compared with Eq. (5), additional items  $f_1$  and  $f_2$  correspond to the effect of the reduced volumetric flux and the reduced impact area, respectively. The limitation of this model is the same with Eq. (5). This model was validated by experimental data provided by the authors themselves, with spray inclination angle varying from 0 to 55°. The accuracy of the model was improved to ±25%.

Another empirical model was developed based on the liftoff model, by Lin and Ponnappan (2002). In this model, there is a slight difference from the traditional liftoff model: the vapour layer not only isolates the liquid layer from the heated surface, but also makes the surface droplet-proof. The empirical correlation was evolved from Eq. (4), presented as:

$$q_{CHF}^n = c We^{-1/3} \rho_v (C_{p,l} \Delta T + h_{fg}) \left(\frac{\rho_l}{\rho_v}\right)^n \quad (9)$$

where  $c$  and  $n$  were unknown beforehand, and then obtained using the experimental CHF data that  $c=0.386$  and  $n=0.549$ , with the standard errors of 0.039 for  $c$ , 0.0154 for  $n$ , and 0.937 for the estimate. Eq. (9) was compared with experimental data of both Lin and Ponnappan (2002), and Mudawar and Estes (1996). The accuracy of of Eq. (9) was ±33%.

Up to now, the applicabilities of all empirical models are limited to their validated conditions. In the future work, the validation of models needs to be conducted with other refrigerants and surface conditions. On the other hand, more factors should be included to the model. For instance, the velocity of droplets was verified to have an essential effect on CHF in spray cooling (Chen et al. 2002), but has not been included in any model.

### 3. Small area spray cooling with a single nozzle

In the past few decades, there had been great interests on spray cooling with a single nozzle over a small area of the order of 1 cm<sup>2</sup> as a potential cooling solution for high power

electronic chips. In order to further understand the heat transfer mechanism of spray cooling as well as enhance the cooling capacity, researchers have made many efforts to conduct parametric studies on spray cooling, such as mass flow rate (Pais et al., 1992; Estes and Mudawar, 1995; Yang et al., 1996), pressure drop across the nozzle (Lin et al., 2003), gravity (Kato et al., 1995; Yoshida et al., 2001; Baysinger et al., 2004; Yerkes et al., 2006), subcooling of coolant (Hsieh et al., 2004; Viasaria and Mudawar, 2008), surface roughness and configuration (Sehmbey et al., 1990; Pais et al., 1992; Silk et al., 2004; Weickgenannt et al. 2011), and spray nozzle orientation and inclination angle (Rybicki and Mudawar, 2006; Lin and Ponnappan, 2005; Li et al., 2006; Viasaria and Mudawar, 2008; Wang et al., 2010). Moreover, it was suggested that spray characteristics, such as spray droplet diameter, droplet velocity and droplet flux, played a paramount role in spray cooling.

Generally, there are two kinds of sprays implemented for spray cooling; pressurised spray and gas-assisted spray. Pressurised sprays are widely utilised in spray cooling researches and applications, which are generated by high pressure drop across the nozzle or with the aid of a swirl structure inside in some cases. Gas-assisted spray is rarely used in spray cooling due to its complex system structure for introducing the secondary gas into the nozzle to provide fine liquid droplets. However, it is found that gas-assisted spray can provide faster liquid droplet speed, smaller droplet size and more even droplet distribution on the heated surface compared with pressurised spray at similar working conditions (Pais et al., 1992; Yang et al., 1996). Eventually, it could provide better heat transfer and higher CHF.

By using the single pressurised spray nozzle on a small heated surface of 3 cm<sup>2</sup>, Tilton (1989) obtained heat fluxes of up to 1000 W/cm<sup>2</sup> at surface superheat within 40 °C while the average droplet diameter and the mean velocities of droplets in that study were approximately 80 µm and 10 m/s, respectively. Tilton concluded that a reduction of spray droplet diameter ( $d_{32}$ ) increased the heat transfer coefficient; the mass flow rate may not be a paramount factor for CHF. Another experimental study also showed that smaller droplets at smaller flow rates can produce the same values of CHF as larger droplets at larger flow rates (Sehmbey et al., 1995).

Estes and Mudawar (1995) performed experiments with a single pressurised nozzle on a copper surface of 1.2 cm<sup>2</sup>, and developed correlations for the droplets' Sauter Mean Diameter (SMD,  $d_{32}$ ) and CHF, which fitted their experimental data within a mean absolute error of 12.6% using water, FC-87 and FC-72 as working fluids. The spray characteristics were captured by a non-intrusive technique: Phase Doppler Anemometry (PDA). It was found that CHF correlated with SMD successfully and reached a higher value for the nozzle which produced smaller droplets.

A different view proposed by Rini et al. (2002) was that the dominant spray characteristic is the droplet number flux ( $N$ ). Chen et al. (2002) proposed that the mean droplet velocity ( $V$ ) had the most dominant effect on CHF followed by the mean droplet number flux ( $N$ ). They also conclude that the SMD ( $d_{32}$ ) did not appear to have an effect on CHF and the mass flow rate was not a dominant parameter of CHF. The increasing droplet velocity and droplet number flux resulted in increases of CHF and heat transfer coefficient. Experimental results indicated that a dilute spray with large droplet velocities excelled in increasing CHF compared with a denser spray with lower velocities for a certain droplet flux. Recently, Zhao et al. (2010) tested the heat transfer sensitivity of both droplet parameters and the flow rate by a numerical method. They concluded that both finer droplets and higher flow rate are favorable in increasing the heat transfer ability of spray cooling. In addition, the contribution of bubble boiling varies with the superheat temperature of the heated surface.

In the case of low superheat condition, the majority of heat transfer in spray cooling is due to the droplet impingement. The effect of bubble boiling increases with the increment of the surface superheat. At the surface superheat over 30 °C, the bubble boiling is responsible for more than 50% of the total heat transfer in spray cooling.

## 4. Large area spray cooling with multiple nozzles

### 4.1 Experimental studies

As mentioned above, the predominant interest of spray cooling in the published literature focused on cooling a small heated surface of the order of 1 cm<sup>2</sup> using a single nozzle or a small array of nozzles. Fewer researchers investigated large area spray cooling, of the order of 10 cm<sup>2</sup> or more using multiple nozzles. Lin et al. (2004) carried out experiments using FC-72 on the heated surfaces (2.54 x 7.6 cm<sup>2</sup>) for two orientations using an array of multiple-nozzle plate (4 x 12) as shown in Figure 11. The maximum heat flux measured over the large area surface was 59.5 W/cm<sup>2</sup> with the heater in a horizontal downward-facing position.

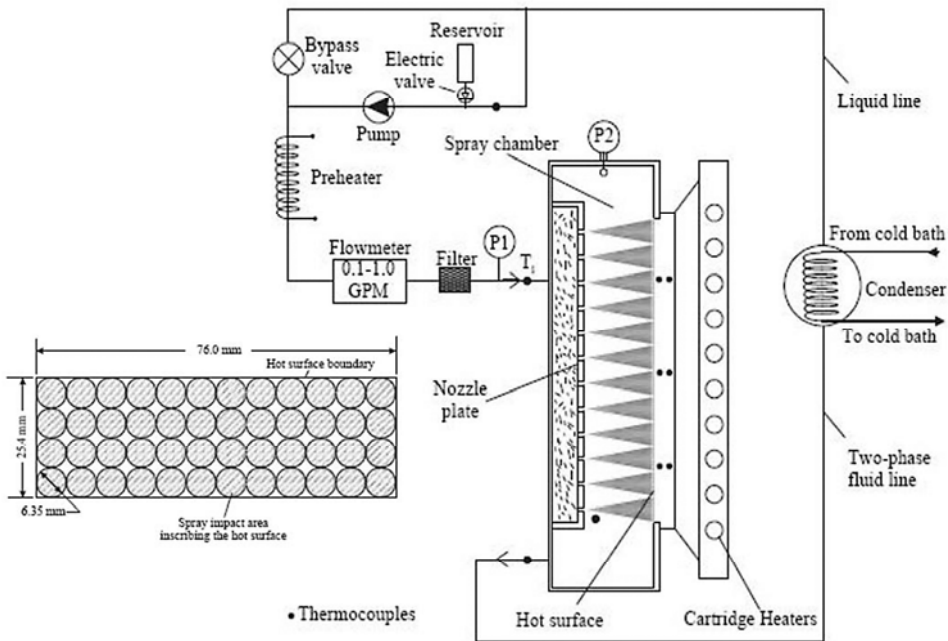

Fig. 11. Schematic of test rig of Lin et al. (2004)

Glassman et al. (2004) conducted an experimental study with a fluid management system for a 4 x 4 nozzle array spray cooler to cool a heated copper plate (4.5 x 4.5 cm<sup>2</sup>). With the help of fluid management system or suction system on this 16 spray nozzle array, the heat transfer was improved on the average by 30 W/cm<sup>2</sup> for similar values of superheat above 5 °C. It was concluded that increasing the amount of suction increased the heat flux and thus the heat transfer coefficient. Suction effectiveness was improved greatly by adding extra

siphons outside the spray area. Additionally, suction effectiveness was also increased by adding small slits to the sides of the siphons.

Yan et al. (2010a, 2010b) conducted an experimental study on large area spray cooling of the order of 100 cm<sup>2</sup> with multiple nozzles. As illustrated in Figure 12, the experimental facility, using R-134a as the working fluid and a heated plate of up to 1 kW power with built-in thermocouples, enabled a wide range of variables to be explored. A particular investigation is to reduce the spray chamber volume by using an inclined spray. The design of the spray chamber for the inclined spray nozzle kept the heated surface and spray coverage closely similar to that for the normal spray nozzle, as shown in Figure 13, but with a lower spray height ( $H_N$ ) of 20 mm, which reduced the volume of the spray chamber from 1509.8 cm<sup>3</sup> to 762.3 cm<sup>3</sup>. This was achieved by using four gas-assisted nozzles with a spray angle of 70° positioned with an inclination angle of 39° relative to the heated surface in the normal position. Vapour flow through the nozzle was utilized to thin the liquid film on the heated surface through shear forces, sweep away the coolant undergoing heat transfer with the heated surface as well as reduce the vapour partial pressure above the liquid film to enhance evaporative heat transfer.

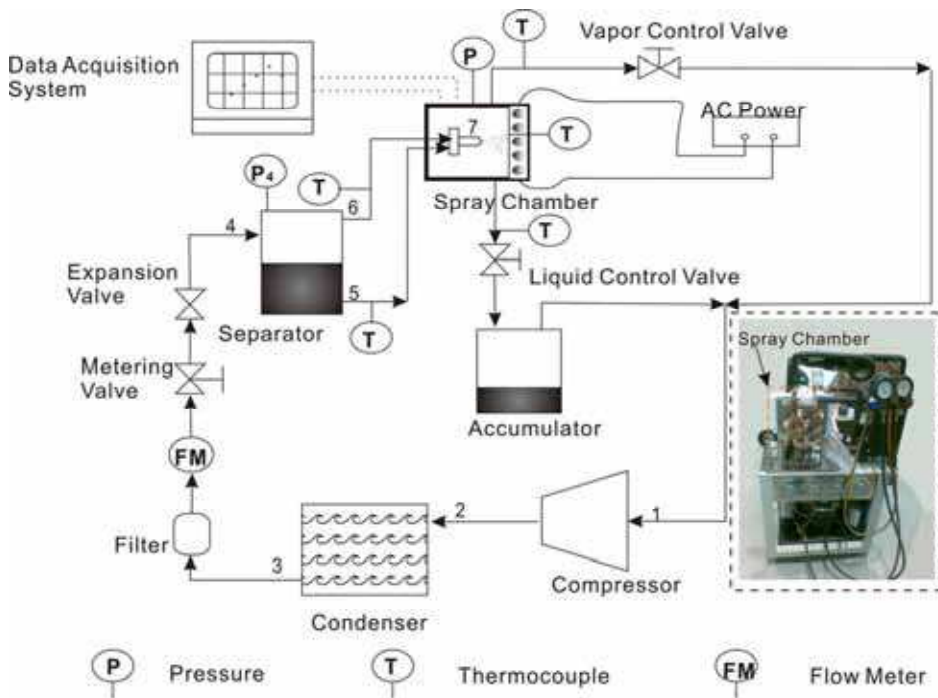

Fig. 12. Experimental set-up of impingement spray cooling (Yan et al., 2010a)

The experimental results suggest that increasing the coolant mass flow rate, nozzle inlet pressure and chamber pressure will have positive effects on the heat transfer effectiveness of impingement spray cooling as shown in Figures 14a, 15a and 16a. Uniformity of the heated surface temperature can be reached with higher mass flow rate and nozzle inlet pressure; however it is not affected by varying chamber pressure as seen in Figures 14b, 15b and 16b.

Partial liquid accumulation might have occurred on the heated surface, due to interactions between sprays as well as the less effective drainage of un-evaporated coolant on such a large heated surface.

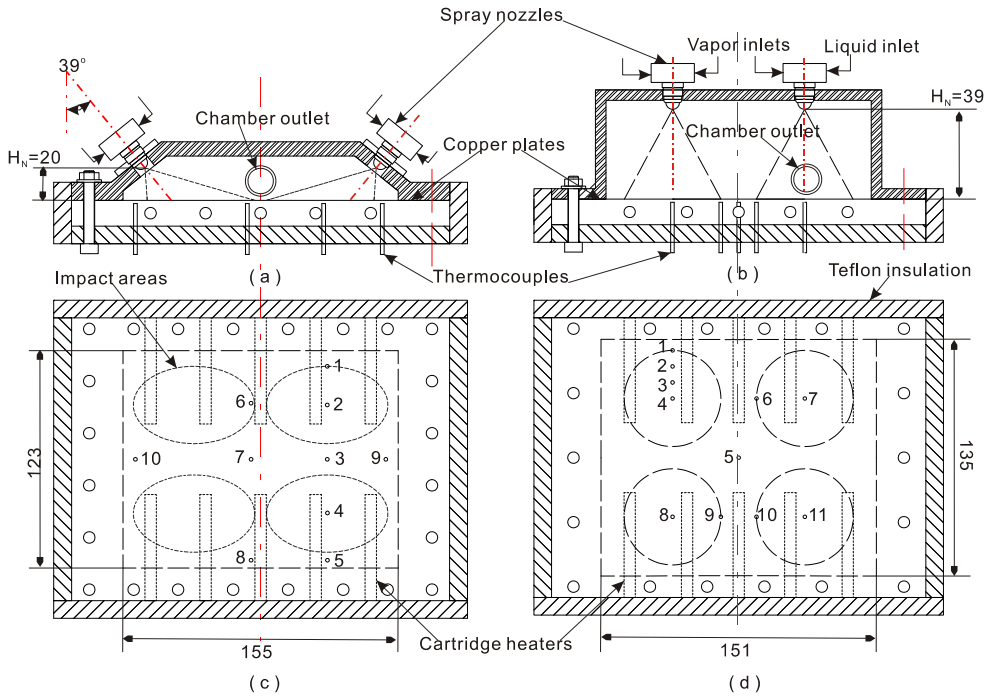

Fig. 13. Schematics of multiple normal spray chamber and inclined spray chamber (Yan et al., 2010c)

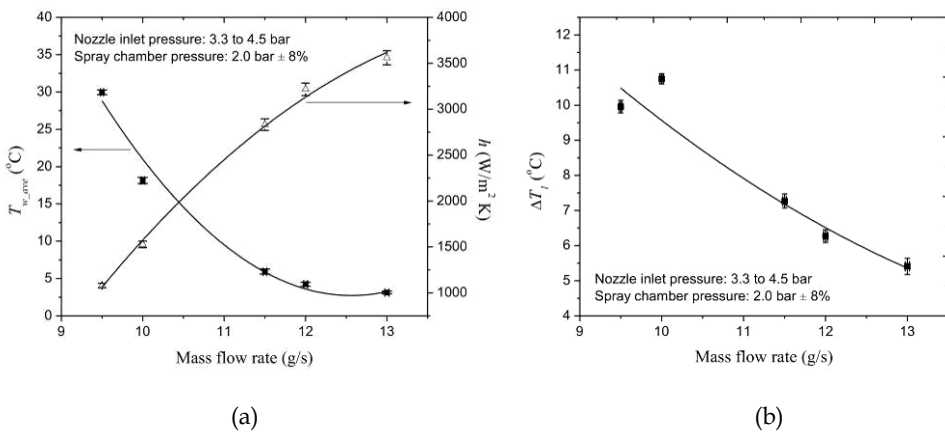

Fig. 14. Effect of mass flow rate (Yan et al., 2010a)



A comparison of the thermal performances between the normal spray and inclined spray shows that although the heat transfer coefficient of the inclined spray configuration is higher compared with the normal spray configuration, the normal spray produces better surface temperature uniformity. The higher heat transfer coefficient by the inclined spray is attributed to the intensified forced convection in the liquid film caused by the large droplet velocity in the horizontal direction and consequent improvements in nucleate boiling and transient conduction occurring on the heated surface due to the quick refresh of the liquid film. It would intensify turbulent mixing in the liquid film and improve the drainage of the refrigerant in the spray chamber. Better surface temperature uniformity by the normal spray results from its more even volumetric flux distribution over the heated surface compared with that of the inclined spray (Yan et al. 2010c).

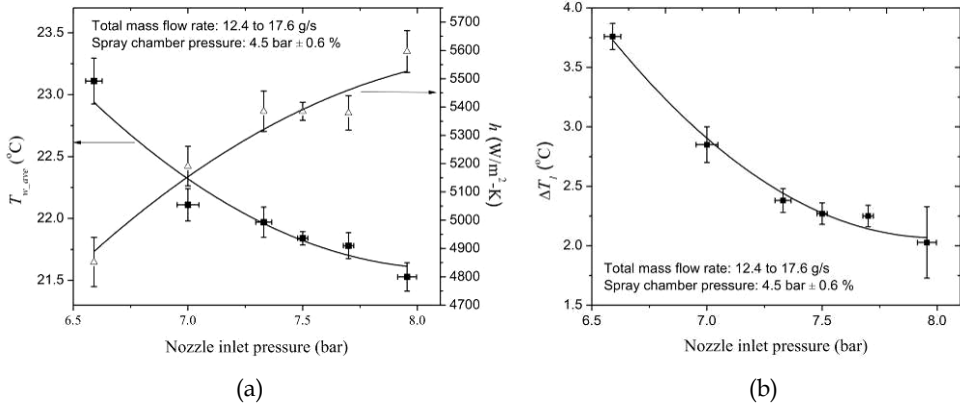

Fig. 15. Effect of nozzle inlet pressure (Yan et al., 2010a)

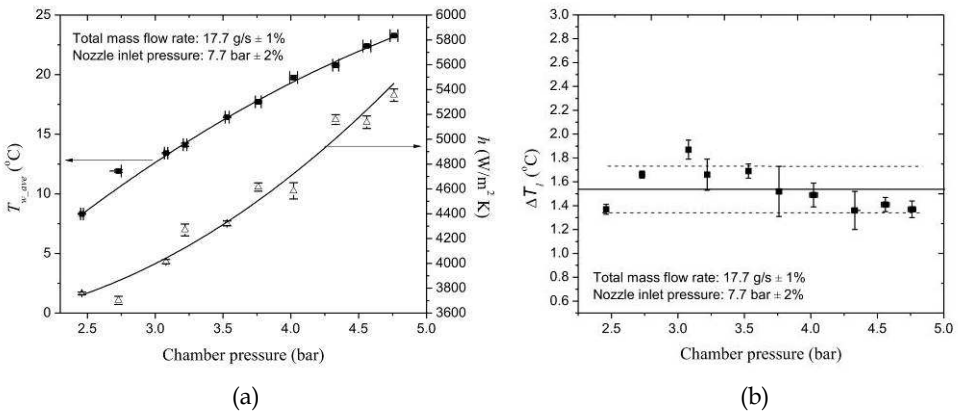

Fig. 16. Effect of spray chamber pressure (Yan et al., 2010a)

The mechanisms of spray cooling heat transfer have been widely debated. Zhao et al. (2010) suggested that two mechanisms responsible for the majority of the heat transfer in spray

cooling are the heat transfer due to the droplet impingement and the heat transfer due to the bubble boiling. They built a numerical model based on droplet dynamics, film hydraulics, and bubble boiling, to capture the heat transfer in spray cooling by superposing the heat transfer due to the droplet impingement and the bubble boiling (both fixed sited nuclei and secondary nuclei). The heat transfer due to the droplet impingement was modeled based on an empirical correlation for a single droplet and then extended to the full spray cone. The heat transfer due to the bubble boiling was modeled by numerically simulating the process of the bubble growth in the film and its corresponding heat transfer. The film thickness was obtained by solving the continuum equation and the momentum equation of the film. The microscopic parameters of the droplets SMD ( $d_{32}$ ), droplet velocity, and droplet number flux) and their distribution were obtained by experimental tests using a Laser Doppler Anemometry (PDA). The laser beam generated by the laser source (see Figure 17) is split by color separation and form two different channels of green light and blue light. These two channels of light will form orthogonal fringes which can measure the two orthogonal velocity components (vertical direction: z, horizontal direction: x) simultaneously. The droplet size can be measured with the use of the image analysis technique as well. The signals received by the detector will be first processed by the signal processor which combines the functions of counter; buffer interface and coincidence filter, and finally recorded by the computer with data processing software.

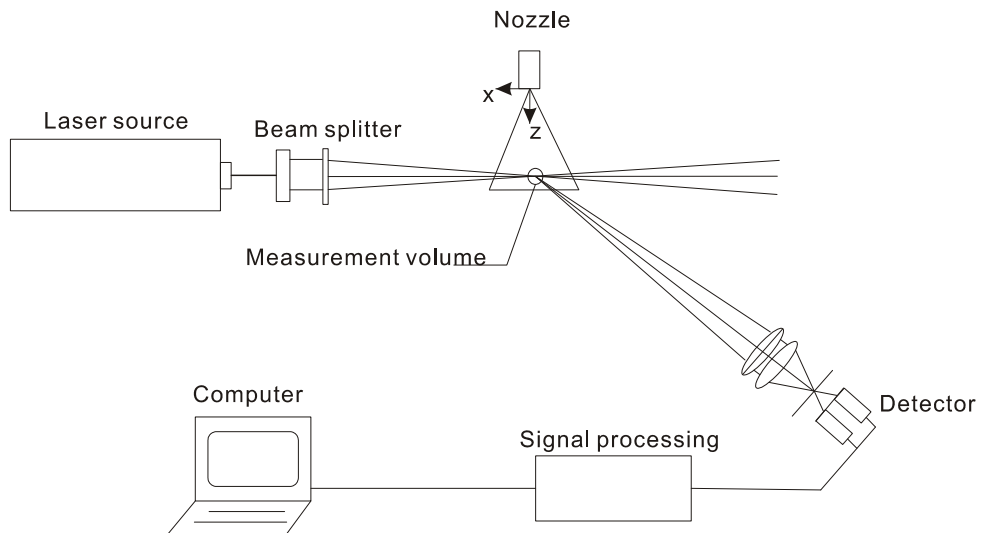

Fig. 17. Schematic of a typical PDA system

Simulations performed for the four-nozzle spray cooling configuration of Figure 15 gave a temperature distribution on the heated surface as shown in Figure 18. It shows that the temperature in the region covered by the spray was lower than outside the spray cones, and the temperature gradient in the center of the heated surface was higher than the edge, which indicates that the heat transfer rate in the center was lower than on the edge due to the liquid congestion between nozzles (Zhao et al., 2011). In addition, the non-uniformity of surface temperature distribution inside the spray cone was also caused by the non-uniform

droplet distribution and the resulting non-uniform distribution of film thickness (Zhao et al. 2010).

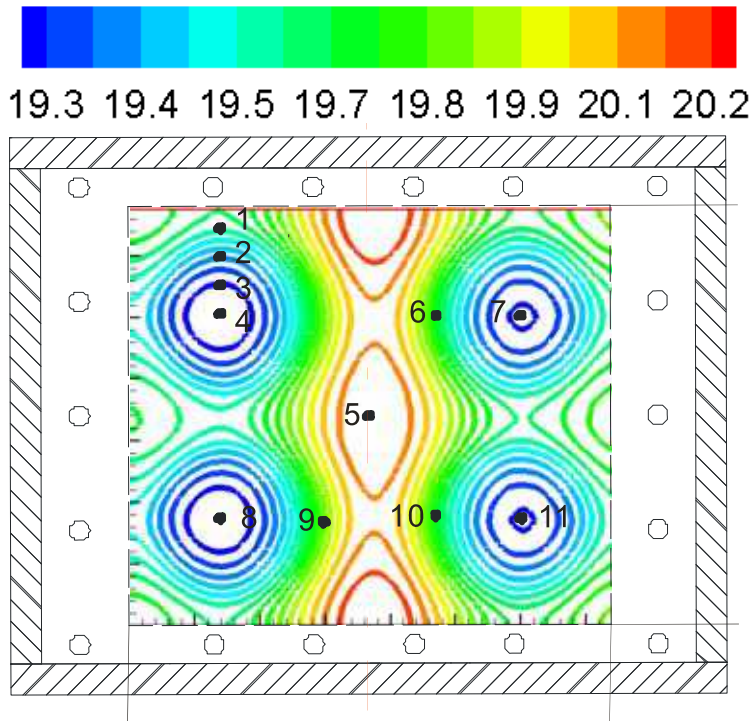

Fig. 18. Simulated surface temperature distribution

No.	1	2	3	4	5	6	7	8	9	10	11	Ave.
Exp.(°C)	19.9	19.8	20.3	19.1	20.1	20.0	19.7	20.0	19.5	20.0	19.9	19.8
Num.(°C)	19.6	19.4	19.3	19.2	20.2	19.9	19.3	19.2	20.0	19.9	19.3	19.6
Dev. (°C)	-0.3	-0.4	-1.0	0.1	0.1	-0.1	-0.4	-0.8	0.5	-0.1	-0.6	±0.2

Table 2. Comparison of simulated temperature distribution with experimental data

Comparisons of the surface temperature with the experimental data are listed in Table 2, and show the validity of the numerical model. The deviation between simulation and experimental temperature is less than  $\pm 0.8^{\circ}\text{C}$ .

**4.2 Comparison between large area and small area spray cooling**

The maximum heat transfer coefficient and CHF of a large area spray cooling performed by Lin et al. (2004) compared with their previous data for a heated cooling surface area of 2.0 cm<sup>2</sup> are lower by about 30% and 34%, respectively. The heated surface area (203 cm<sup>2</sup>) investigated by Yan et al. (2010a) is considerably larger than that by Lin et al. (2 cm<sup>2</sup>) (2003),

and shows a maximum heat transfer coefficient of  $5596 \text{ W/cm}^2$  much lower than that obtained by the latter at a similar level of heat flux, probably a result of un-evaporated liquid accumulating in the chamber. Considering the central region of the heated surface, the interaction of the spray droplets with the counter-current flowing vapor is stronger for the large heated surfaces than the small heated surface as shown in Figure 19. This would result in a thicker liquid film and a smaller heat transfer coefficient, particularly in the central region of the heated surface (Lin et al., 2004). Liquid accumulation at the central region of multiple nozzles was also confirmed by Shedd and Pautsch (2005), and Pautsch and Shedd (2006) through their visualization studies. The liquid film impacted by the four sprays from a multiple nozzle plate experiences a stagnation point in the central region of the heated surface, where virtually all of its initial momentum must be redirected toward the drainage outlet at the edge. Furthermore, it was found that the fluid motion in the central region was very chaotic and that flow velocities were lower than in the thin film surrounding the sprays using a three-color strobe technique for bubble behaviors (Shedd, 2002). Such flow condition with the slow moving liquid could cause the thicker liquid films and lower heat transfer occurring at the central region of the heated surface, compared with the spray impact region. Recently, the liquid congestion among spray cones was also observed by authors' group in a 54-nozzle spray cooling process, as shown in Figure 20. These results show that, for a larger heated surface with multiple spray nozzles, it is much more difficult to control the evaporation, as well as the fluid flow and effective discharge to the outlets. Proper management of the fluid run-off in impingement spray cooling system may improve the cooling performance further.

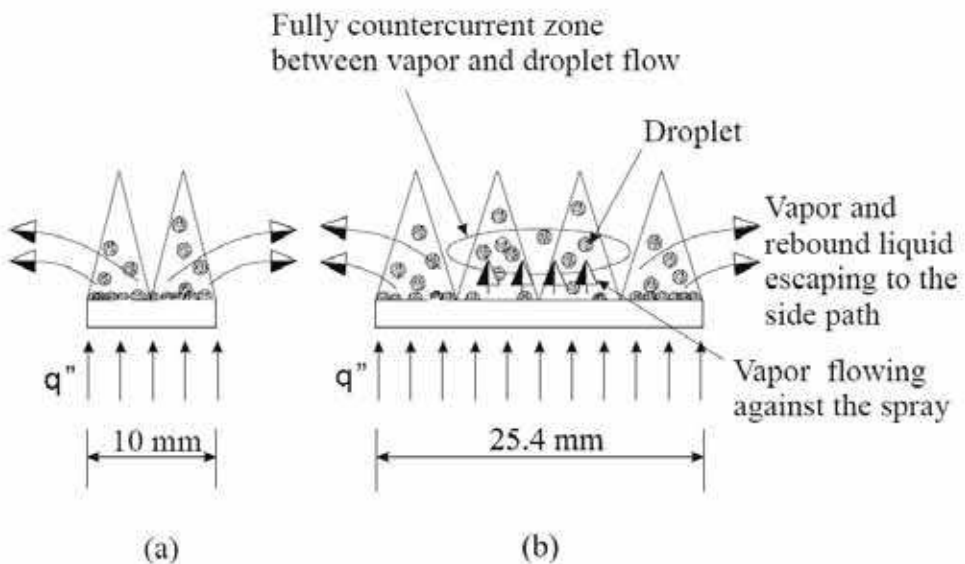

Fig. 19. Interactions between the spray droplets and vapor flow (Lin et al., 2004)



Fig. 20. A transparent surface impinged by a 54-nozzle spray

## 5. Conclusion

Spray cooling is an appropriate technique for high power and high heat flux applications, especially for temperature sensitive devices. By taking advantage of the liquid's relatively high latent heat, liquid impingement spray cooling has demonstrated to be an effective way of removing high heat power from surfaces, requiring only a small surface superheat as well as low mass flow rate, which are essential requirements for a compact cooling system design for a high powered electronic devices. Major heat transfer mechanisms and the critical heat flux (CHF) in spray cooling have been described based on many experimental and numerical investigations. However, more work is required to fully understand the mechanism of spray cooling. There is abundant work in the literature on parametric studies about CHF on small heated surfaces with high heat flux input. However, studies based on spray cooling with multiple nozzles on larger heated surfaces, which are crucial for the thermal management of high power devices mounted on electronic cards and in data centres, are still relatively scarce.

## 6. Nomenclature

$A$	Surface area, $m^2$
$C_p$	Heat capacity at constant pressure, $J \cdot kg^{-1} \cdot K^{-1}$
$d_{32}$	Sauter Mean Diameter, $m$
$\Delta G$	Critical free energy of the homogeneous bubble, $J$

$h_{fg}$	Evaporative latent heat, $J \cdot kg^{-1}$
$h_n$	Spray height, m
$k_B$	Boltzmann constant, -
$k$	Thermal conductivity, $W/m \cdot K$
$l_j$	Wetting front length, m
$\dot{q}''$	Heat flux per unit area, $W/m^2$
$p$	Pressure, pa
$S$	Supersaturation, pa
$T$	Temperature, K
$t$	Time, s
$We$	Weber number, -

### Greek letters

$\alpha$	Thermal diffusivity, $m^2/s$ ; Spray inclined angle, $^\circ$
$\theta$	Spray cone angle, $^\circ$
$\rho$	Density, $kg \cdot m^{-3}$
$\lambda_j$	Vapor wave length, m
$\sigma$	Surface tension, $N \cdot m^{-1}$

### Subscripts

$bub$	Bubble
$I$	Initial condition
$v$	Vapor phase
$l$	Liquid phase
$CHF$	Critical heat flux
$sat$	Saturation

## 7. References

- Aguilar, G., Majaron, B., Verkruysse, W., Zhou, Y., Nelson, J. S. and Lavernia, E. J. Theoretical and experimental analysis of droplet diameter, temperature, and avaporation rate evolution in cryogenic sprays, *International Journal of Heat and Mass Transfer* 44(17): 3201-3211 (2001).
- Anderson T. M., Mudawar I., Microelectronic cooling by enhanced pool boiling of a dielectric fluorocarbon liquid, *Journal of Heat Transfer*, Vol. 111, pp. 752-759, (1989).
- Azar K., *Advanced cooling concepts and their challenges*, Ed. www.qats.com. Advanced Thermal Solutions, Inc. (2002).
- Bar-Cohen, A., Sherwood, G., Hodes, M. and Solbreken, G., Gas-assisted evaporative cooling of high density electronic modules. *IEEE transactions on components, packaging, and manufacturing technology. Part A* Vol. 18 (3), pp: 502-509 (1995).
- Bar-Cohen, A., Arik M., Ohadi, M., *Direct Liquid Cooling of High Flux Micro and Nano Electronic Components*. *Proceeding of IEEE*, Vol. 94, pp. 1549-1570 (2006).
- Carey V.P., *Liquid-vapour phase-change phenomena*, Hemisphere Publishing Corporation, (1992).

- Chen R.H., Chow L.C., Navedo J.E., Effects of spray characteristics on critical heat flux in sub-cooled water spray cooling, *International Journal of Heat and Mass Transfer*, Vol. 45, pp. 4033-4043 (2002).
- Demiray F., Kim J., Micro-scale heat transfer measurements during pool boiling of FC-72: effect of subcooling. *International Journal of Heat and Mass Transfer*, Vol. 47, pp. 3257-3268 (2004).
- Esmailizadeh L., Mesler R., Bubble entrainment with drops, *Journal of Colloid and Interface Science*, Vol. 110 (2), pp. 561-574 (1986).
- Faulkner, D., Khotan, M., and Shekarriz, R., Practical Design of a 1000 W/cm<sup>2</sup> Cooling System, In: 19th IEEE SEMI-THERM Symposium, pp. 223-230, San Jose, USA, (2003).
- Girshick, S.L., Chiu, C.-P., Kinetic nucleation theory: A new expression for the rate of homogeneous nucleation from an ideal supersaturated vapor, *The Journal of Chemical Physics* 93 (2), pp. 1273-1277 (1990)
- Glassman B.S., Kuravi S., Du J., Lin Y.-R., Zhao G.C., Chow L.C., A Fluid Management System for a Multiple Nozzle Array Spray Cooler, In: 37th AIAA Thermo-physics Conference, Portland, Oregon, (2004).
- Glassman B.S., Spay cooling for land, sea, air and space based applications, a fluid management system for multiple nozzle spray cooling and a guide to high heat flux heater design, Master of Science Thesis, Department of Mechanical, Materials and Aerospace Engineering, University of Central Florida, (2005).
- Huddle J.J., Chow L.C., Lei S., Marcos A., Rini D.P., Lindauer S.J., Bass M., Delfyett P. J., Thermal management of Diode laser arrays, In: 16th IEEE SEMI-THERM™ Symposium (2000).
- Horacek, B., Kim, J., Kiger, K., Spray cooling using multiple nozzles: visualization and wall heat transfer measurements. *IEEE Transactions on Device and Materials Reliability*, Vol. 4 (4), pp. 614-625 (2004).
- Horacek, B., Kiger, K., Kim, J., Single nozzle spray cooling heat transfer mechanisms. *International Journal of Heat and Mass Transfer*, Vol. 48 (8), pp. 1425-1438 (2005).
- Hsieh, S. S., Weng, C. J. and Chiou, J. J., Nucleate pool boiling on ribbed surfaces with micro-roughness at low and moderate heat flux. *Transactions of the ASME. Journal of Heat Transfer* Vol. 121 (2), pp: 376-385 (1999).
- Hsieh S., Fan T., Tsai H., Spray cooling characteristics of water and R-134a. Part 1: nucleate boiling. *International Journal of Heat and Mass Transfer*, Vol. 47. pp. 5703-5712 (2004).
- Incropera F.P., Dewitt D.P., *Fundamentals of Heat and Mass Transfer*. 5<sup>th</sup> ed. New York: John Wiley & Sons (2002).
- Li, B. Q., Cader, T., Schwarzkopf, J., Okamoto, K. and Ramaprian, B., Spray angle effect during spray cooling of microelectronics: Experimental measurements and comparison with inverse calculations. *Applied Thermal Engineering* Vol. 26 (16), pp: 1788-1795 (2006).
- Lin, L., Ponnappan, R., Critical heat flux of multi-nozzle spray cooling in a closed loop. *Proceedings of the Intersociety Energy Conversion Engineering Conference* (2002).
- Lin L., Ponnappan R., Yerkes K., Hager B., Large area spray cooling. In: 42nd AIAA Aerospace Sciences Meeting and Exhibit, Reno, Nevada, pp. 10838-10843 (2004).

- Lin, L., Ponnappan, R., Two-phase high capacity spray cooling loop - Nozzle orientation effects and performance results. Collection of Technical Papers - 3rd International Energy Conversion Engineering Conference, San Francisco, California (2005).
- Marto, P.J., Mackenzie D.K., Rivers A. D., Nucleate boiling in thin liquid films, *AICHe Symposium Series*, Vol. 73 (164), pp. 228-235 (1977).
- Melser R., Mailen G., Nucleate boiling in thin liquid films, *AICHe Journal*, Vol. 23, pp. 954-957 (1977).
- Mertens, R. G., Chow, L., Sundaram, K. B., Cregger, R. B., Rini, D. P., Turek, L. and Saarioos, B. A., Spray cooling of IGBT devices. *Journal of Electronic Packaging, Transactions of the ASME* 129(3): 316-323 (2007).
- Estes, K. A. and Mudawar, I., Correlation of sauter mean diameter and critical heat flux for spray cooling of small surfaces. *International Journal of Heat and Mass Transfer* Vol. 38 (16), pp: 2985-2996 (1995).
- Mudawar I., Estes K.A., Optimizing and predicting CHF in spray cooling of a square surface. *Journal of Heat Transfer*, Vol. 118, pp. 672-679 (1996).
- Mudawar I., Assessment of high-heat flux thermal management schemes, *IEEE transactions on Components and Packaging Technologies*, Vol. 24 (2), pp. 122-141 (2001).
- Nevedo J., Parametric effects of spray characteristics on spray cooling heat transfer, Ph.D. Dissertation, Department of Mechanical Material and Aerospace Engineering, University of Central Florida (2000).
- Nishikawa K., Kusuda H., Yamasaki K., and Tanaka K., Nucleate boiling at low levels, *Bulletin of JSME*, Vol. 10 (38), pp. 328-338 (1967).
- Overholt, M.R., McCandless, A., Kelly, K.W., Becnel, C.J., and Motakef, S., Micro-Jet Arrays for Cooling of Electronic Equipment, In: 3rd International Conference on Microchannels and Minichannels, PART B, pp. 249-252 (2005).
- Pautsch A.G., Shedd T.A., Spray impingement cooling with single- and multi-nozzle arrays. Part 1: Heat transfer data using FC-72. *International Journal of Heat and Mass Transfer*, Vol. 48, pp. 3167-3175 (2005).
- Pais M.R., Chow L.C., Mahefkey E.T., Surface roughness and its effect on the heat transfer mechanism in spray cooling, *Journal of Heat Transfer*, Vol. 114, pp. 211-219 (1992).
- Rainey K.N., You S.M., Lee S., Effect of pressure, subcooling, and dissolved gas on pool boiling heat transfer from microporous, square pin-finned surfaces in FC-72. *International Journal of Heat Transfer*, Vol. 46, pp. 23-35 (2003a).
- Riffat S.B., Ma X., Improving the coefficient of performance of thermoelectric cooling systems: a review, *International Journal of Energy Research*, Vol. 28, pp. 753-768 (2004).
- Rini D.P., Pool boiling and spray cooling with FC-72, Ph.D. dissertation, Department of Mechanical, Materials and Aerospace Engineering, University of Central Florida, 2000
- Rini D.P., Chen R.-H., Chow L.C., Bubble behavior and nucleate boiling heat transfer in saturated FC-72 spray cooling, *Journal of Heat Transfer*, Vol. 124, pp. 63-72 (2002).
- Rohsenow M.W., Hartnett J.P., Ganic E.N., *Handbook of Heat Transfer Fundamentals*, 2<sup>nd</sup> edition, McGraw Hill Inc., NY (1985).
- Rybicki, J. R. and Mudawar, I., Single-phase and two-phase cooling characteristics of upward-facing and downward-facing sprays. *International Journal of Heat and Mass Transfer* Vol. 49 (1-2), pp: 5-16 (2006).



- Sehmbey M.S., Pais M.R., Chow L.C., Effect of surface material properties and surface characteristics in evaporative spray cooling. In: AIAA/ASME 5th Joint Thermophysics and Heat Transfer Conference, AIAA 90-1728, Seattle, WA (1990).
- Sellers S.M., Heat transfer resulting from the evaporation of liquid droplets on a horizontal heated surface, Ph.D. dissertation, School of Mechanical Engineering, Georgia Institute of Technology (2000).
- Selvam R.P., Baskara S., Balda J.C., Barlow F., and Elshabini A., Computer Modeling of Liquid Droplet Impact on Heat Transfer During Spray Cooling, American Society of Mechanical Engineers Paper HT2005-72569 (2005).
- Selvam R.P., Lin L., Ponnappan R., Direct Simulation of Spray Cooling: Effect of Vapour Bubble Growth and Liquid Droplet Impact on Heat Transfer, *International Journal of Heat and Mass Transfer*, Vol. 49, Nos. 23–24, pp. 4265–4278 (2006).
- Selvam R.P., Sarkar M., Sarkar S., Ponnappan R., and Yerkes K.L., Modeling thermal-boundary-layer effect on liquid-vapour interface dynamics in spray cooling. *Journal of Thermophysics and Heat Transfer*, Vol. 23(2) pp. 356–370 (2009).
- Shedd, T.A., Single- and three-color strobe techniques for bubble/droplet sizing and velocimetry, in: C.-F. Lee (Ed.), *ILASS 2002, ILASS Americas*, Madison, WI, pp. 376–380 (2002).
- Shedd T.A., Pautsch A.G., Spray impingement cooling with single- and multiple-nozzle arrays. Part II: Visualisation and empirical models. *International Journal of Heat Mass Transfer*, Vol. 48, pp. 3176–3184 (2005).
- Sigler J., Mesler R., The behavior of the gas film formed upon drop impact with a liquid surface, *International Journal of Colloid and Interface Science*, Vol. 134 n2, pp. 459–474 (1990).
- Silk E.A., Golliher E.L., Selvam R.P., Spray cooling heat transfer: Technology overview and assessment of future challenges for micro-gravity application. *Energy Conversion and Management*, Vol. 49(3), pp. 453–468 (2008).
- Sturgis J.C., Mudawar I., Critical heat flux in a long, rectangular channel subjected to one-sided heating – II. Analysis of critical heat flux data, *International Journal of Heat Mass and Transfer*, Vol. 42, pp. 1849–1862 (1999).
- Tan S.-W., Computer simulation of a spray cooling system with FC-72, Ph.D. dissertation, Department of Mechanical, Materials and Aerospace Engineering, University of Central Florida, (2001).
- Tilton, D. E., Tilton, C. L., Moore, C. J. and Ackerman, R. E., Spray cooling for the 3-D cube computer. In: *Intersociety Conference on Thermal Phenomena in Electronic Systems*, Washington, DC, USA (1994).
- Tuckerman, D.B., and Pease, R.F.W., High-Performance Heat Sink for VLSI, *IEEE Electron Device Letters*, Vol. 2, pp. 126–129 (1981).
- Wang Y., Liu M., Liu D., Xu K., and Chen Y., Experimental study on the effects of spray inclination on water spray cooling performance in non-boiling regime. *Experimental Thermal and Fluid Science*, Vol. 34, pp. 933–942 (2010).
- Weickgenannt, C. M., Zhang, Y., Lembach, A. N., Roisman, I. V., Gambaryan-Roisman, T., Yarin, A. L. and Tropea, C., Nonisothermal drop impact and evaporation on polymer nanofiber mats. *Physical Review E - Statistical, Nonlinear, and Soft Matter Physics* Vol. 83 (3), (2011).

- Wendelstorf, J., Spitzer, K.-H., Wendelstorf, R., Spray cooling heat transfer at high temperature and liquid mass fluxes, *International Journal of Heat and Mass Transfer*, Vol. 51, pp. 4902-4910 (2008).
- Visaria M., Mudawar I., Theoretical and experimental study of the effects of spray inclination on two-phase spray cooling and critical heat flux, *International Journal of Heat and Mass Transfer*, Vol. 51, pp. 2398-2410 (2008).
- Yan, Z. B., Toh, K. C., Duan, F., Wong, T. N., Choo, K. F., Chan, P. K. and Chua, Y. S., Experimental study of impingement spray cooling for high power devices. *Applied Thermal Engineering* Vol. 30 (10), pp: 1225-1230 (2010a).
- Yan, Z. B., Duan, F., Wong, T. N., Toh, K. C., Choo, K. F., Chan, P. K., Chua, Y. S. and Lee, L. W., Large area spray cooling by inclined nozzles for electronic board. 12th Electronics Packaging Technology Conference, EPTC 2010, Singapore (2010b).
- Yan, Z. B., Duan, F., Wong, T. N., Toh, K. C., Choo, K. F., Chan, P. K., Chua, Y. S. and Lee, L. W., Large area impingement spray cooling from multiple normal and inclined spray nozzles, submitted (2010c).
- Yang J., Spray cooling with an air atomizing nozzle, Ph.D. dissertation, School of Mechanical Engineering, University of Kentucky (1993).
- Yang J., Chow L.C., Pais M.R., Nucleate boiling heat transfer in spray cooling, *Journal of Heat Transfer*, Vol. 188, pp. 668-671 (1996).
- Zhang, H., Mudawar, I., Hasan, M. M., Flow boiling CHF in microgravity. *International Journal of Heat Mass Transfer*, Vol. 48, pp. 3107-3118 (2005).
- Zhao, R., Cheng, W. L., Liu, Q. N. and Fan, H. L., Study on heat transfer performance of spray cooling: Model and analysis. *Heat and Mass Transfer/Waerme- und Stoffuebertragung* Vol. 46 (8-9), pp: 821-829 (2010).
- Zhao, R., Duan, F., Wong, T. N., Toh, K. C., Choo, K. F., Chan, P. K., and Chua, Y. S., Numerical simulation of spray cooling heat transfer with multi-nozzle arrays, submitted (2011).
- Zhirnov, V.V., Cavin, R.K., Hutchby, J.A., Bourianoff, G.I., 2003. Limits to binary logic switch scaling - a Gedanken model. *Proceedings of the IEEE* 91 (11), 1934-1939.
- Zuo Z.J., North M.T., and Wert K.L., High Heat Flux Heat Pipe Mechanism for Cooling of Electronics, *IEEE transactions on Components and Packaging Technologies*, Vol. 24 (2), pp. 220-225 (2001).

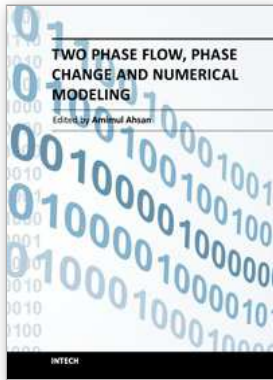

## **Two Phase Flow, Phase Change and Numerical Modeling**

Edited by Dr. Amimul Ahsan

ISBN 978-953-307-584-6

Hard cover, 584 pages

**Publisher** InTech

**Published online** 26, September, 2011

**Published in print edition** September, 2011

The heat transfer and analysis on laser beam, evaporator coils, shell-and-tube condenser, two phase flow, nanofluids, complex fluids, and on phase change are significant issues in a design of wide range of industrial processes and devices. This book includes 25 advanced and revised contributions, and it covers mainly (1) numerical modeling of heat transfer, (2) two phase flow, (3) nanofluids, and (4) phase change. The first section introduces numerical modeling of heat transfer on particles in binary gas-solid fluidization bed, solidification phenomena, thermal approaches to laser damage, and temperature and velocity distribution. The second section covers density wave instability phenomena, gas and spray-water quenching, spray cooling, wettability effect, liquid film thickness, and thermosyphon loop. The third section includes nanofluids for heat transfer, nanofluids in minichannels, potential and engineering strategies on nanofluids, and heat transfer at nanoscale. The fourth section presents time-dependent melting and deformation processes of phase change material (PCM), thermal energy storage tanks using PCM, phase change in deep CO<sub>2</sub> injector, and thermal storage device of solar hot water system. The advanced idea and information described here will be fruitful for the readers to find a sustainable solution in an industrialized society.

### **How to reference**

In order to correctly reference this scholarly work, feel free to copy and paste the following:

Zhibin Yan, Rui Zhao, Fei Duan, Teck Neng Wong, Kok Chuan Toh, Kok Fah Choo, Poh Keong Chan and Yong Sheng Chua (2011). Spray Cooling, Two Phase Flow, Phase Change and Numerical Modeling, Dr. Amimul Ahsan (Ed.), ISBN: 978-953-307-584-6, InTech, Available from: <http://www.intechopen.com/books/two-phase-flow-phase-change-and-numerical-modeling/spray-cooling>

**INTECH**  
open science | open minds

### **InTech Europe**

University Campus STeP Ri  
Slavka Krautzeka 83/A  
51000 Rijeka, Croatia  
Phone: +385 (51) 770 447  
Fax: +385 (51) 686 166  
[www.intechopen.com](http://www.intechopen.com)

### **InTech China**

Unit 405, Office Block, Hotel Equatorial Shanghai  
No.65, Yan An Road (West), Shanghai, 200040, China  
中国上海市延安西路65号上海国际贵都大饭店办公楼405单元  
Phone: +86-21-62489820  
Fax: +86-21-62489821

© 2011 The Author(s). Licensee IntechOpen. This chapter is distributed under the terms of the [Creative Commons Attribution-NonCommercial-ShareAlike-3.0 License](#), which permits use, distribution and reproduction for non-commercial purposes, provided the original is properly cited and derivative works building on this content are distributed under the same license.