

Control of Hybrid Electrical Vehicles

Gheorghe Livinț, Vasile Horga, Marcel Rățoi and Mihai Albu
*Gheorghe Asachi Technical University of Iași
Romania*

1. Introduction

Developing cars is a major factor that has determined the increasing of the civilization degree and the continuous stimulation of the society progress. Currently, in Europe, one in five active people and in the US, one in four, directly work in the automotive industry (research, design, manufacture, maintenance) or in related domains (fuel, trade, traffic safety, roads, environmental protection). On our planet the number of the cars increases continuously and he nearly doubled in the last 10 years. With increasing number of cars entered in circulation every year, is held and increasing fuel consumption, increased environmental pollution due to emissions from internal combustion engines (ICE), used to their propulsion. Reducing oil consumption takes into account the limited availability of petroleum reserves and reducing emissions that affect the health of population in large urban agglomerations. The car needs a propulsion source to develop a maximum torque at zero speed. This can not be achieved with the classic ICE. For ICE power conversion efficiency is weak at low speeds and it has the highest values close to the rated speed. Pollution reduction can be achieved by using electric vehicles (EV), whose number is still significant. The idea of an electrical powered vehicle (EV) has been around for almost 200 years. The first electric vehicle was built by Thomas Davenport in 1834 [Westbrook, 2005]] But over time, the batteries used for energy storage could provide the amount of electricity needed to fully electric propulsion vehicles. Electric vehicles are powered by electric batteries which are charged at stations from sources supplied by electrical network with electricity produced in power plants. Currently, a lot of researches are focused on the possibility of using fuel cells for producing energy from hydrogen. EV with fuel cell can be a competitive alternative to the standard ICE that is used in today's cars. If performance is assessed overall thrust of the effort wheel and crude oil consumed for the two solutions: classic car with ICE and car with electric motor powered by electric batteries, the difference between their yields is not spectacular. In terms of exhaust emissions is the net advantage for electric vehicles. Pollutant emissions due to energy that is produced in power plants (plant property, located) are much easier to control than those produced by internal combustion engines of vehicles that are individual and scattered. Power plants are usually located outside urban areas, their emissions affects fewer people living in these cities. By using electric motors and controllers efficient, electric vehicles provide the means to achieve a clean and efficient urban transport system and a friendly environment. Electric vehicles are zero emission vehicles, called ZEV type vehicles (Zero-Emissions Vehicles).

Any vehicle that has more than one power source can be considered hybrid electric vehicle (HEV). But this name is used most often for a vehicle using for propulsion a combination of an electric drive motor and an ICE, which energy source is fossil fuel. The first patent for involving HEV technology was filed in 1905 by the American H. Piper. The change of focus to hybrid technology was done by almost all vehicle manufacturers. Many prototypes and a few mass produced vehicles are now available. For example, there were 23 hybrid electric presented at the North American International Auto Show (NAIAS) in 2000 [Wyczalek, 2000].

There are several configurations of electric and hybrid vehicles [Bayindir, 2011, Ehsani, 2005]: 1. electric vehicles equipped with electric batteries and/or supercapacitors called BEV (Battery Electric Vehicles), 2. hybrid electric vehicles which combine conventional propulsion based on ICE engine with petroleum fuel and electric propulsion with motor powered by batteries or supercapacitors called HEV (Hybrid Electric Vehicles), 3. electric vehicles equipped with fuel cells, called FCEV (Fuel Cell Electric Vehicles).

Concept of hybrid electric vehicle with ICE-electric motor aims to overcome the disadvantages of the pure electric vehicles, whose engines are powered by electric batteries: the limited duration of use (low autonomy) and time recharging for batteries.

2. Hybrid electric vehicles

A hybrid electric vehicle is distinguished from a standard ICE driven by four different parts: a) a device to store a large amount of electrical energy, b) an electrical machine to convert electrical power into mechanical torque on the wheels, c) a modified ICE adapted to hybrid electric use, d) a transmission system between the two different propulsion techniques. Figure 1 shows the possible subsystems of a hybrid vehicle configuration [Chan, 2002], [Ehsani, 2005]

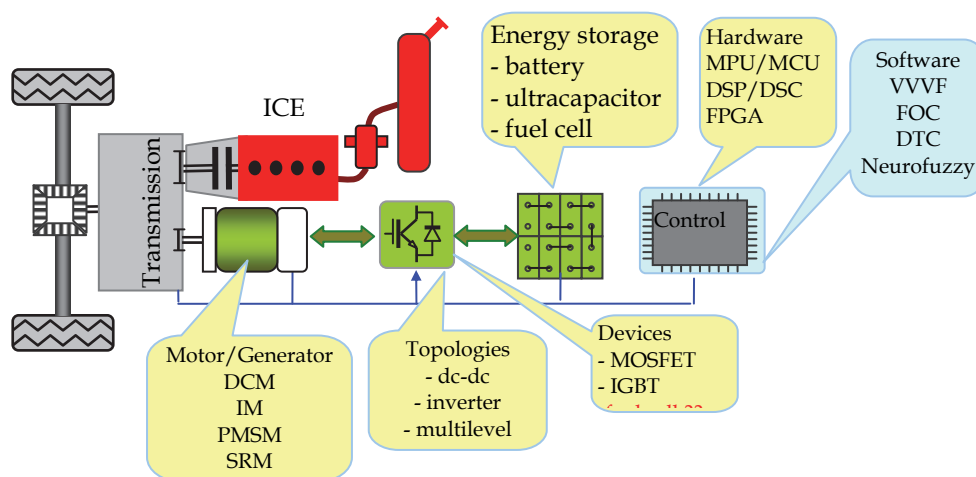

Fig. 1. Main components of a hybrid electric vehicle

The devices used to store electrical energy could be batteries, hydrogen powered fuel cell or supercapacitors. Electric motors used on hybrid vehicles are [Husain 2003], [Fuhs, 2009]: DC motors, induction motors (IM), permanent magnet synchronous motors (PMSM) or switching reluctance motors (SRM). The HEV can use the electrical machine to behave as a generator and thereby produce electrical energy, which can be stored and used later. The ICE may be the same type as those on conventional vehicles, but it must be designed and optimized for hybrid vehicles. The transmission system between the ICE and the electrical machine is typically of series or parallel architecture. For power electronics are used MOSFET or IGBT transistors, and the command can be done with microprocessor, microcontroller or DSP using various techniques (VVVF - variable voltage and variable frequency, FOC -field oriented control, AC - adaptive control, NC - neural control or FC- fuzzy control).

Electric vehicles with two energy sources are also called hybrid vehicles. On hybrid-electric vehicles, in addition to the main battery, special batteries or capacitors, as a secondary energy source are used. These secondary energy sources are designed to provide power for short periods of peak operating conditions - for example, during the ascent of a slope or during acceleration. This is necessary because some batteries with the highest energy density have low power density. Since power density is required at least 150 [W/kg] for a good acceleration and slope climbing performance, a secondary source with high power density is essential. This power density is easily obtained from a lead-based battery and this is an auxiliary battery that is suitable for use with an aluminum-air battery in a hybrid-electric vehicle.

A combination of hybrid electric vehicle that is under development and of great interest, thanks to improvements in fuel cell, is the electric vehicle powered with fuel cell and an auxiliary battery. This battery can provide a high current necessary to start and can also serve as a load limiting device which allows the fuel cell to operate at low power first and then warm for a high power operation. This arrangement enhances the efficiency of the entire system and also allows the vehicle to use the recuperative braking.

Another class of hybrid electric vehicles, called hybrid electromechanical vehicles, use in addition to the main electric drive powered by batteries and a mechanical energy storage device such as a flywheel, or a hydraulic accumulator [Westbrook, 2005]. Hybrid electric vehicles represents a bridge between the present vehicle powered by ICEs and vehicles of the future characterized by a near-zero emissions, ULEV (Ultra-Low-Emission-Vehicle) or, in some cases even without pollution (ZEV-Zero-Emission Vehicle), as it is expected to be electrically propelled vehicles powered by fuel cells supplied with hydrogen.

It is very important to be reminded that without taking the technology steps and to improve the hybrid propulsion systems it is not possible to achieve higher level of the propulsion technology which uses fuel cells.

Currently a number of construction companies sell hybrid electric vehicles in series production: Toyota, Honda, Ford, General Motors. Many other companies have made prototypes of hybrid electric vehicles, the shift in mass production is only a matter of time that depends on the improvement of operating parameters and manufacturing cost reductions. Regarding the line of a hybrid electric vehicle powertrain, it is complex in terms of construction, operation and electronic control system than the most evolved similar vehicle equipped with conventional internal combustion engine.

Viewed from the standpoint of integration components, hybrid electric vehicle represents, compared with the vehicle solution powered ICE, an increase of complexity approximately 25%, while in terms of system control input hardware and software is at least double. These new elements make the price a such vehicle to be higher than that of a vehicle powered

only by internal combustion engine. Thus, as shown in [Ehsani, 2005] the first vehicle (car) series hybrid electric Toyota designed by the company line is the most sophisticated and most advanced integrated powertrain control strategy of the firm ever made known to promote ideas of great ingenuity and technical complexity.

2.1 Architectures of hybrid electric drive trains

The architecture of a hybrid vehicle is defined as the connection between the components of the energy flow routes and control ports. Hybrid electric vehicles were classified into two basic types: series and parallel. But presently HEVs are classified into four kinds: series hybrid, parallel hybrid, series-parallel hybrid and complex. The primary power source (steady power source) is made up of fuel tank and ICE and battery-electric motor is taken as secondary source (dynamic power source).

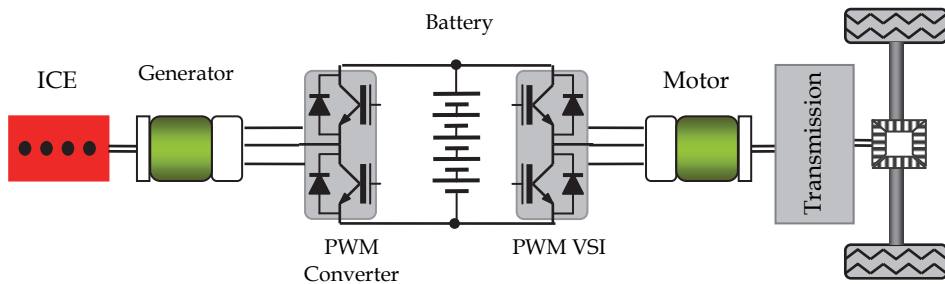

Fig. 2. Series HEV

A series hybrid drive train uses two power sources which feeds a single powerplant (electric motor) that propels the vehicle. In Figure 2 is shown a series hybrid electric drive train where: fuel tank is an unidirectional energy source and the ICE coupled to an electric generator is a unidirectional energy converter. The electric generator is connected to an electric power bus through an electronic converter (rectifier). Electrochemical battery pack is the bidirectional energy source and is connected to the power bus by means of a power electronics converter (DC/DC converter). Also the electric power bus is connected to the controller of the electric traction motor. The traction motor can be controlled either as a motor (when propels the vehicle) or as generator (to vehicle braking). A battery charger can charge batteries with the energy provided by an electrical network.

The possible operating modes of series hybrid electric drive trains are [Ehsani, 2005]:

1. Pure electric: ICE is stopped and the vehicle is propelled only by batteries energy,
2. Pure engine mode: the vehicle is powered with energy provided by electric generator driven by engine. The batteries no provide and do not take energy from the drive train.
3. Hybrid mode: The traction power is drawn from both the engine-generator and the batteries.
4. Engine traction and battery charging mode: The ICE-generator provides the energy needed for the batteries charging and the propulsion vehicle.
5. Regenerative braking mode: the engine is turned off and the traction motor is operated as generator and the energy provided is used to charge the batteries.
6. Batteries charging mode: The engine – generator charges the batteries and the traction motor is not supplied.
7. Hybrid batteries

charging mode: Both the engine-generator and the traction motor operate as generator to charge the batteries.

For series hybrid drive trains the following advantages can be mentioned: 1. Because the ICE is mechanical decoupled from the driven wheels and thus the ICE can operate solely within its maximum efficiency region, at a high-speed where and the emissions are reduced. 2. Electric motors have near-ideal torque-speed characteristics and multigear transmissions are not necessary. 3. The electrical transmission provides the mechanical decoupling and allows the using of a simple control strategy. The series hybrid electric drive trains have some disadvantages: 1. The mechanical energy of the ICE is first converted to electrical energy in the generator and the output energy of generator is converted into mechanical energy in the traction motor. The losses in the generator and the traction motor may be significant and these reduce the system efficiency. 2. The generator adds additional weight and cost. 3. The traction motor must be designed to meet maximum requirements, because only it is used for the vehicle propulsion.

Series hybrid electric vehicles applications include TEMSA – Avenue hybrid bus, Mercedes-Citaro bus and MAN-Lion's City Hybrid bus. Series hybrid configuration is mostly used in heavy vehicles, military vehicles and buses [Bayindir, 2011].

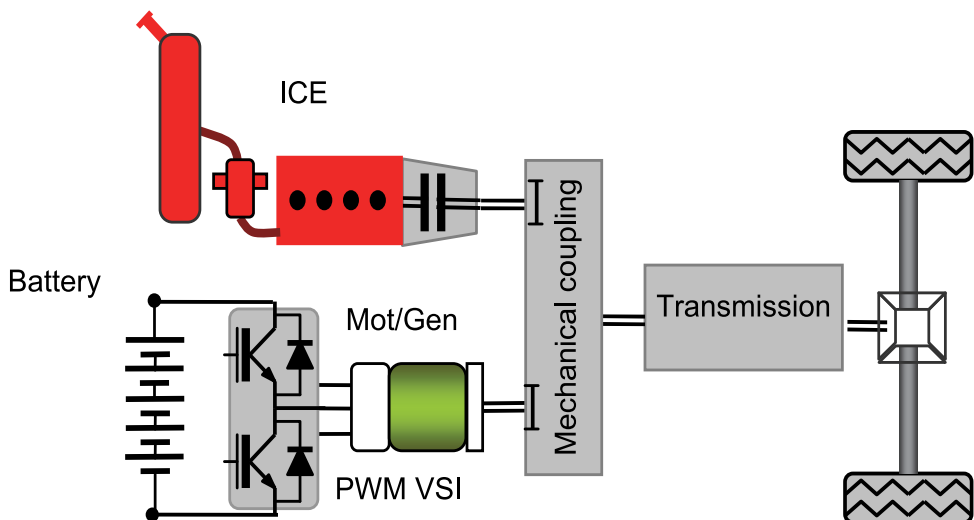

Fig. 3. Parallel HEV

In the parallel configuration the power of the ICE and the electric motor are added into mechanical coupling, as shown in Figure 3 and operate the drive train by the mechanical transmission. There are different combination of the engine and electric motor power:

1. Torque-coupling parallel hybrid electric drive trains, 2. Speed-coupling parallel hybrid electric drive trains, 3. Torque-coupling and speed-coupling parallel hybrid electric drive trains. The torque coupling adds the torques of the engine T_{in1} , and the electric motor, T_{in2} , together or splits the engine torque into two parts: vehicle propelling and battery is charging. In this case the output torque, T_{out} , and speed, ω_{out} , can be described by

$$T_{out} = k_1 T_{in1} + k_2 T_{in2} \quad , \quad \omega_{out} = \frac{\omega_1}{k_1} = \frac{\omega_2}{k_2} \quad (1)$$

where k_1 and k_2 are the constants determined by the parameters of torque coupling. The speed coupling adds the speeds of the engine, ω_{in1} , and the electric motor, ω_{in2} , together by coupling their speeds. The output speed ω_{out} and torque, T_{out} , can be described by:

$$\omega_{out} = k_1 \omega_{in1} + k_2 \omega_{in2} \quad , \quad T_{out} = \frac{T_{in1}}{k_1} + \frac{T_{in2}}{k_2} \quad (2)$$

where k_1 and k_2 are the constants determined by the parameters of speed coupling. In parallel hybrid electric vehicle various control strategies can be used. In the most common strategies, ICE is used in on mode and operates at almost constant power output at its area of maximum efficiency. If the power requested from drive train is higher than the output power of ICE, the electric motor is turned on, ICE and electric motor supply power to the drive train. If the power requested from drive train is less than the output power of the ICE, the remaining power is used for charging the batteries. In this configuration, regenerative braking power on a down slope driving is used to charge the batteries. Examples of the parallel hybrid electric vehicles are [Fuhs, 2009]: Insight model introduced by Honda, Ford Escape Hybrid SUV and Lexus Hybrid SUV.

3. Energy storage for HEV

For hybrid electric vehicles three electromechanical devices are important: batteries supercapacitors and fuel cells (FC). The batteries provide storage of energy that is essential for regenerative braking. Also the batteries are a source of energy that is necessary for electric-only propulsion. Supercapacitors, which have the similar capability, are high-power and low-stored-energy devices. Supercapacitors are used to improve high power peak for short duration. Batteries are heavy and repeated deep discharge adversely affects life. Batteries have much better performance as a provider of peak power for hybrid electric vehicle and/or fuel cell vehicle.

The fuel cell (FC) system has a fuel tank and stores energy in the form of hydrogen. An FC can be used for electric-only propulsion and it cannot be used for regenerative braking.

The batteries can be classified in primary batteries, which cannot be recharged, and secondary batteries, which have reversible reactions and can be charged and discharged. The basic unit of a battery is the voltaic cell. Voltaic cells have the following components parts: the electrodes: anode and cathode, and the electrolyte. Batteries are composed of collections of cells. Each cell has a voltage which depends of the electrochemical potential of the chemicals. Lead acid has a cell potential of 2 V, and Nickel metal hydride (NiMH) has cell potential of 1.2 V. The cells are connected in series for increasing the voltage. Batteries are described by four quantitative features: current, voltage, energy and power. Capacity (C) is the charge that can be taken from the battery under certain conditions, so is the amount of electricity that a battery can provide in continuous discharging. A constant current battery capacity is a function of current values to which they discharge. Battery capacity is expressed in the [Ah] and is given by $C = \int I_d dt$ where I_d is the discharge current and t is the

time of discharge. If the discharge is made at constant current, $C = I_d t$. Cell capacity, C , is determined partially by the mass of available reactants.

3.1 Batteries characteristics

The main batteries characteristics are: specific energy, specific power, self discharge, life, state of charge (SOC).

Specific energy is the ratio between the energy provided of battery and its weight and is expressed in [Wh/kg]. It should be noted that the specific energy storage of gasoline is about 11000 [Wh/kg] versus 90 [Wh/kg] representing a peak through the current batteries. It is noted that lead-based batteries have the lowest energy density as lithium batteries have the highest energy densities. **Specific power**, expressed in [W/kg] or [W/l] represents the ratio between the battery power and its weight or between battery power and its volume. Self discharge consists in the battery power loss due to internal reactions during storage/non-use them, when the external circuit is open (missing load). Self discharge rate depends on battery type, temperature and battery age. Life (number of cycles) is expressed in number of cycles, i.e. the number of complete charge and discharge (until the final voltage permissible or until capacity drops below 80% of initial capacity) that the battery can handle. State of charge - SOC is the ratio of the electric charge Q than can be delivered by the battery at current I , to the nominal battery capacity Q_0

$$SOC = \frac{Q(t)}{Q_0} = \frac{Q_0 - It}{Q_0} \quad (3)$$

Knowing the energy remaining from the initial energy, we get an indication of the time as the battery will continue to work before its charging. SOC decreases as the battery supplies a load and increase SOC when the battery is charging. Note that the SOC does not refer to the maximum capacity that the battery was last charged, but to the initial battery capacity. The degree of discharge (Depth of Discharge - DOD) on each cycle represents the percentage of energy discharged / removed from the battery to each discharge.

3.2 Batteries models used in hybrid electric vehicles

The simplest electrical battery-model is presented in Figure 4.a. It consists of an ideal voltage source V_{OC} , a constant equivalent internal resistance R_i and the terminal voltage represented by V_O [Livint et. all. 2007]. However, the internal resistance is different under discharge and charge conditions. This model does not capture the internal dynamics of the battery, in particular the effect of the diffusion of the electrolytic chemicals between the battery plates. The circuit can be modified as shown in Figure 4.b. for the account the different resistance values under charge and discharge conditions, R_c and R_d . The diodes shown in Figure 4.b have no physical significance in the battery and are included only for modeling purposes.

In order to model the diffusion of the electrolytic through the battery and its resultant effect of causing transient currents in the battery, a capacitor C is added to the model. A dynamical model of the lead-acid battery, presented in Figure 4.c, shows a simplified equivalent circuit proposed in [Livint et al., 2006].

The cell terminal voltage is represented by V_O , and R_i is a lumped resistance due to cell interconnections. A double layer capacitance C_s (surface-capacitor) is shown in parallel with the charge transfer polarization represented by R_i . This double layer capacitor is the results of charge separation at the electrolyte/electrode interface.

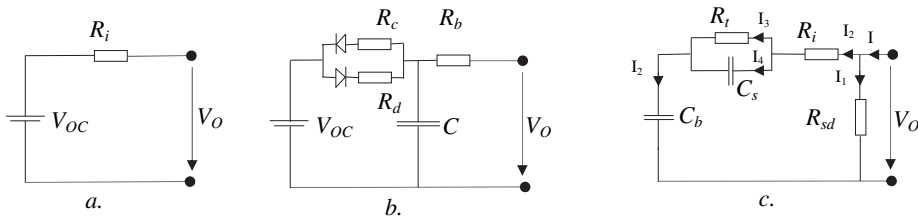

Fig. 4. a. Simple battery model; b. Battery model with the different charging and discharging resistance values and polarization capacitance; c. Simplified equivalent circuit of a lead acid battery

The bulk capacitor C_b models the cell’s open circuit voltage, and R_{sd} is included to represent the self-discharge of the cell.

Voltages and currents describing the characteristics of the model shown in Fig.4.c are given by equations

$$\begin{aligned}
 V_O &= R_i I_2 + V_{C_s} + V_{C_b} = R_{sd} I_1 \\
 V_{C_s} &= \frac{1}{C_s} \int I_4 dt = R_t I_3 \\
 V_{C_b} &= \frac{1}{C_b} \int I_2 dt \\
 I &= I_1 + I_2; I_2 = I_3 + I_4
 \end{aligned}
 \tag{4}$$

where V_{C_b} and V_{C_s} denote the voltages across the bulk- and surface-capacitors, respectively

Taking as state variables the voltages V_O , V_{C_s} , V_{C_b} and assuming that $\frac{dI_2}{dt} \approx 0$ (the rate of change of terminal current per sampling interval, when implemented digitally, is negligible) the complete state variable description (the state model of battery) is obtained:

$$\begin{aligned}
 \begin{bmatrix} \dot{V}_O \\ \dot{V}_{C_s} \\ \dot{V}_{C_b} \end{bmatrix} &= \begin{bmatrix} -\frac{1}{R_{sd}} \left(\frac{1}{C_s} + \frac{1}{C_b} \right) & -\frac{1}{R_t C_s} & 0 \\ -\frac{1}{R_{sd} C_s} & -\frac{1}{R_t C_s} & 0 \\ -\frac{1}{R_{sd} C_b} & 0 & 0 \end{bmatrix} \begin{bmatrix} V_O \\ V_{C_s} \\ V_{C_b} \end{bmatrix} = \begin{bmatrix} \frac{1}{C_s} + \frac{1}{C_b} \\ \frac{1}{C_s} \\ \frac{1}{C_b} \end{bmatrix} I \\
 y = V_O &= [1 \ 0 \ 0] [V_O \ V_{C_s} \ V_{C_b}]^T
 \end{aligned}
 \tag{5}$$

The control strategies for hybrid and electric vehicles are based on SOC knowledge. The batteries behavior can be modeled with different electrical circuit structures and different linear or nonlinear mathematical models. The different estimation methods can be used for the batteries parameters determination. The method based on continue time model and LIF algorithm assures a good accuracy for parameters estimation. The estimated parameters can be used for the battery SOC determination.

4. Electric motors used for hybrid electric vehicles propulsion

4.1 Motor characteristics versus electric traction selection

The electric motors can operate in two modes: a) as motor which convert electrical energy taken from a source (electric generator, battery, fuel cell) into mechanical energy used to propel the vehicle, b) as generator which convert the mechanical energy taken from a motor (ICE, the wheels during vehicle braking, etc..) in electrical energy used for charging the battery. The motors are the only propulsion system for electric vehicles. Hybrid electric vehicles have two propulsion systems: ICE and electric motor, which can be used in different configurations: serial, parallel, mixed. Compared with ICE electric motors has some important advantages: they produce large amounts couples at low speeds, the instantaneous power values exceed 2-3 times the rated ICE, torque values are easily reproducible, adjustment speed limits are higher. With these characteristics ensure good dynamic performance: large accelerations and small time both at startup and braking.

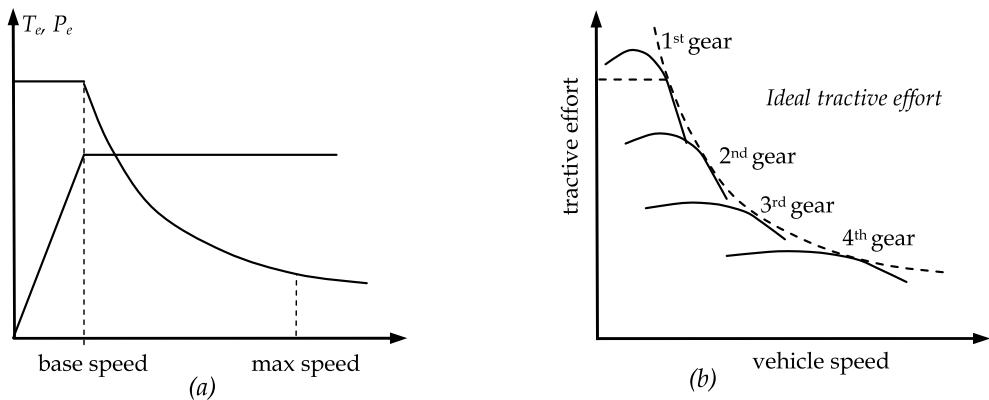

Fig. 5. a. Characteristics of traction motors ; b. Tractive effort characteristics of an ICE vehicle

Figure 5.a illustrates the standard characteristics of an electric motor used in EVs or HEVs. Indeed, in the constant-torque region, the electric motor exerts a constant torque (rated torque) over the entire speed range until the rated speed is reached. Beyond the rated speed of the motor, the torque will decrease proportionally with speed, resulting in a constant power (rated power) output. The constant-power region eventually degrades at high speeds, in which the torque decreases proportionally with the square of the speed. This characteristic corresponds to the profile of the tractive effort versus the speed on the driven wheels [Figure 5. b.]. This profile is derived from the characteristics of the power source and the transmission. Basically, for a power source with a given power rating, the profile of the tractive effort versus the speed should be a constant.

The power of the electric motor on a parallel type hybrid vehicle decisively influences the dynamic performance and fuel consumption. The ratio of the maximum power the electric motor, P_{EM} , and ICE power P_{ICE} is characterized by hybridization factor which is defined by the relation HF

$$HF = \frac{P_{EM}}{P_{EM} + P_{ICE}} = \frac{P_{EM}}{P_{HEV}} \quad (6)$$

where P_{HEV} is the maximum total traction power for vehicle propulsion. It is demonstrated that it reduces fuel consumption and increase the dynamic performance of a hybridization factor optimal point more than one critic ($HF=0.3 \div 0.5$) above the optimal point increase in ICE power hybrid electric vehicle does not improve performance.

The major requirements of HEVs electric propulsion, as mentioned in literature, are summarized as follows [Chan 2005], [Husain 2003], [Ehsani 2005]:

1. a high instant power and a high power density;
2. a high torque at low speeds for starting and climbing, as well as a high power at high speed for cruising;
3. a very wide speed range, including constant-torque and constant-power regions;
4. a fast torque response;
5. a high efficiency over the wide speed and torque ranges;
6. a high efficiency for regenerative braking;
7. a high reliability and robustness for various vehicle operating conditions; and
8. a reasonable cost.

Moreover, in the event of a faulty operation, the electric propulsion should be fault tolerant . Finally, from an industrial point of view, an additional selection criterion is the market acceptance degree of each motor type, which is closely associated with the comparative availability and cost of its associated power converter technology [Emadi 2005].

4.2 Induction motors used in hybrid electric vehicles

4.2.1 Steady state operation of induction motor

Induction motor is the most widely used ac motor in the industry. An induction motor like any other rotating machine consists of a stator (the fixed part) and a rotor (the moving part) separated by air gap. The stator contains electrical windings housed in axial slots. Each phase on the stator has distributed winding, consisting of several coils distributed in a number of slots. The distributed winding results in magnetomotive forces (MMF) due to the current in the winding with a stepped waveform similar to a sine wave. In three-phase machine the three windings have spatial displacement of 120 degrees between them. When balanced three phase currents are applied to these windings, the resultant MMF in the air gap has constant magnitude and rotates at an angular speed of $\omega_s = 2\pi f_s$ electrical radians per second. Here f_s is the frequency of the supply current. The actual speed of rotation of magnetic field depends on the number of poles in the motor. This speed is known as synchronous speed Ω_s of the motor and is given by

$$\Omega_s = \frac{\omega_s}{p} = \frac{2\pi f_s}{p} = \frac{2\pi n_s}{60}; \quad n_s = \frac{60 f_s}{p} \quad (7)$$

where p is number of pole pairs, n_s [rpm], is the synchronous speed of rotating field.

If the rotor of an induction motor has a winding similar to the stator it is known as wound rotor machine. These windings are connected to slip rings mounted on the rotor. There are stationary brushes touching the slip rings through which external electrical connected. The wound rotor machines are used with external resistances connected to their rotor circuit at

the time of starting to get higher starting torque. After the motor is started the slip rings are short circuited. Another type of rotor construction is known as squirrel cage type rotor. In this construction the rotor slots have bars of copper or aluminium shorted together at each end of rotor by end rings. In normal running there is no difference between a cage type or wound rotor machine as far as their electrical characteristics are concerned.

When the stator is energized from a three phase supply a rotating magnetic field is produced in the air gap. The magnetic flux from this field induces voltages in both the stator and rotor windings. The electromagnetic torque resulting from the interaction of the currents in the rotor circuit (since it is shorted) and the air gap flux, results in rotation of rotor. Since electromotive force in the rotor can be induced only when there is a relative motion between air gap field and rotor, the rotor rotates in the same direction as the magnetic field, but it will not run at synchronous speed. An induction motor therefore always runs at a speed less than synchronous speed. The difference between rotor speed and synchronous speed is known as slip. The slip s is given by

$$s = \frac{\Omega_s - \Omega}{\Omega_s} = \frac{\Omega_{sl} - \Omega}{\Omega_s} = 1 - \frac{\Omega}{\Omega_e}; \text{ or } s = \frac{n_s - n}{n_s} = \frac{n_{sl} - n}{n_s} = 1 - \frac{n}{n_s} \tag{8}$$

where: n [rpm] is the speed of the rotor.

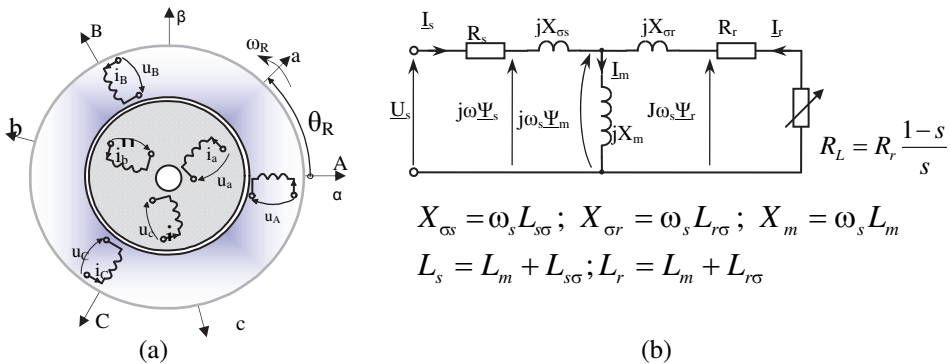

Fig. 6. Cross section of an induction motor (a); Equivalent circuit of an IM (b)

The steady state characteristics of induction machines can be derived from its equivalent circuit. In order to develop a per phase equivalent circuit of a three-phase machine, a wound rotor motor as shown in Figure 6.a. is considered here. In case of a squirrel cage motor, the rotor circuit can be replaced by an equivalent three-phase winding. When three-phase balanced voltages are applied to the stator, the currents flow in them. The equivalent circuit, therefore is identical to that of a transformer, and is shown in Figure 6. b. Here R_s is the stator winding resistance, L_s is self inductance of stator, L_r is self inductance of rotor winding referred to stator, R_r is rotor resistance referred to stator, L_m is magnetizing inductance and s is the slip. The parameters of the equivalent circuit are the stator and rotor leakage reactances $X_{\sigma s}$ and $X_{\sigma r}$, magnetizing reactance X_m , and the equivalent resistance

$$R_L = \frac{1-s}{s} R_r \text{ which depends on the slip } s.$$

The ohmic losses on this "virtual" resistance, R_L , represent the output mechanical power, P_{mec} , transferred to the load. Thus the electromagnetic torque, T_e , is given as

$$T_e = \frac{P_{mec}}{\Omega} = \frac{3p}{(1-s)\omega_s} \frac{(1-s)R_r}{s} I_r^2 = \frac{3p}{\omega_s} \frac{R_r}{s} I_r^2 \quad (9)$$

If statoric leakage reactance is neglected it results

$$T_e = 3p \left(\frac{U_s}{\omega_s} \right)^2 \frac{R_r s}{R_r^2 + (\omega_{sl} L_{r\sigma})^2} \quad (10)$$

For applications where high degree of accuracy in speed control is not required simple methods based on steady state equivalent circuit have been employed. Since the speed of an induction motor, n , in revolutions per minute is given by

$$n = \frac{60f_s}{p}(1-s) \quad (11)$$

Thus the speed of the motor can be changed by controlling the frequency, or number of poles or the slip. Since, number of poles of a motor is fixed at the time of construction, special motors are required with provision of pole changing windings.

4.2.2 The dynamic model of the induction motor

The dynamic model of ac machine can be developed [Ehsani, 2005], [Husain, 2003], using the concept of “space vectors”. Space vectors of three-phase variables, such as the voltage, current, or flux, are very convenient for the analysis and control of ac motors and power converter. A three-phase system defined by $y_A(t)$, $y_B(t)$, and $y_C(t)$ can be represented uniquely by a rotating vector $\underline{y}(t)$ in the complex plane.

$$\underline{y}(t) = \frac{2}{3}(y_A(t) + \underline{a} \cdot y_B(t) + \underline{a}^2 \cdot y_C(t)) = y_D(t) + j \cdot y_Q(t) \quad (12)$$

where $\underline{a} = e^{j(2\pi/3)}$

Under simplifying assumptions (symmetrical windings with sinusoidal distribution, negligible cross-section of the conductors, ideal magnetic circuit) the induction squirrel cage machine may be described in an arbitrary synchronous reference frame, at ω_g speed, by the following complex space vector equations [Livint et al 2006]:

$$\begin{cases} \underline{u}_{sg} = R_s \cdot \underline{i}_{sg} + \frac{d\underline{\psi}_{sg}}{dt} + j\omega_g \underline{\psi}_{sg}; & 0 = R_r \cdot \underline{i}_{rg} + \frac{d\underline{\psi}_{rg}}{dt} + j(\omega_g - \omega_r) \underline{\psi}_{rg} \\ \underline{\psi}_{sg} = L_s \underline{i}_{sg} + L_m \underline{i}_{rg}; & \underline{\psi}_{rg} = L_m \underline{i}_{sg} + L_r \underline{i}_{rg} \\ t_e = -\frac{3}{2} p L_m \underline{i}_{sg} \times \underline{i}_{rg}; & J \frac{d\Omega}{dt} = t_e - D\Omega - t_l \end{cases} \quad (13)$$

where: $\underline{x}_{sg} = \underline{x}_s e^{-j\theta_s}$; $\underline{x}_{rg} = \underline{x}_r e^{-j(\theta_s - \theta_r)}$; $\omega_g = \frac{d\theta_g}{dt}$ - speed of the arbitrary reference frame,

$\omega_r = p\Omega = \frac{d\theta_r}{dt}$ - speed of the rotor reference frame.

In order to achieve the motor model in stator reference frame on impose $\omega_g=0$, in equations (13).

4.3 Power converters

Power converters play a vital role in Hybrid Electric Vehicle (HEV) systems. Typical HEV drive train consists of a battery, power converter, and a traction motor to drive the vehicle. The power converter could be just a traditional inverter or a dc-dc converter plus an inverter. The latter configuration provides more flexibility and improves the system performance. The dc-dc converter in this system interfaces the battery and the inverter dc bus, and usually is a variable voltage converter so that the inverter can always operate at its optimum operating point. In most commercially available systems, traditional boost converters are used. A power converter architecture is presented in Figure 7.

Voltage source inverters (VSI) are used in hybrid vehicles to control the electric motors and generators. The switches are usually IGBTs for high-voltage high power hybrid configurations, or MOSFETs for low-voltage designs. The output of VSI is controlled by means of a pulse-width-modulated (PWM) signal to produce sinusoidal waveform. Certain harmonics exist in such a switching scheme. High switching frequency is used to move the harmonics away from the fundamental frequency.

A three-phase machine being feed from a VSI receives the symmetrical rectangular three-phase voltages shown in Figure 8.a. Inserting these phase voltage in the space vector definition of stator voltage $\underline{u}_s(t) = \frac{2}{3}(u_{sA}(t) + a u_{sB}(t) + a^2 u_{sC}(t))$, yields the typical set of six active switching state vectors $U_1 \dots U_6$ and two zero vectors U_0 and U_7 as shown in Figure 8.b.

$$\underline{u}_s = \begin{cases} \frac{2}{3} U_{dc} e^{j \cdot k \cdot 2\pi/3} & k = 1, \dots, 6 \\ 0 & k = 0, 7 \end{cases} \quad (14)$$

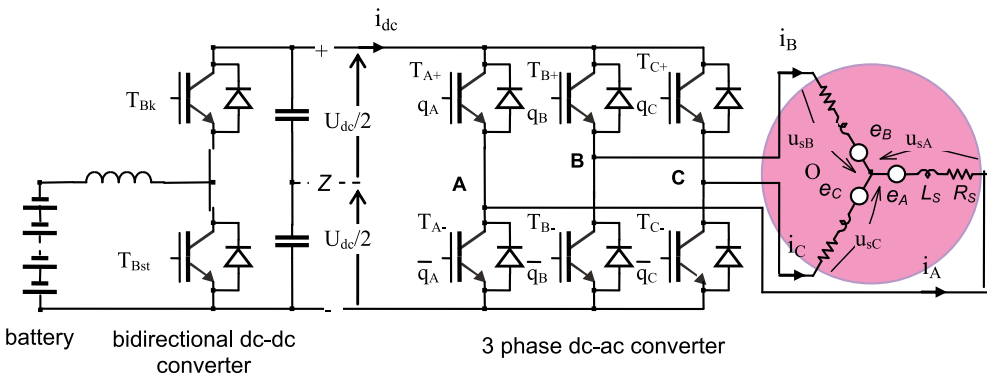

Fig. 7. Power converter architecture

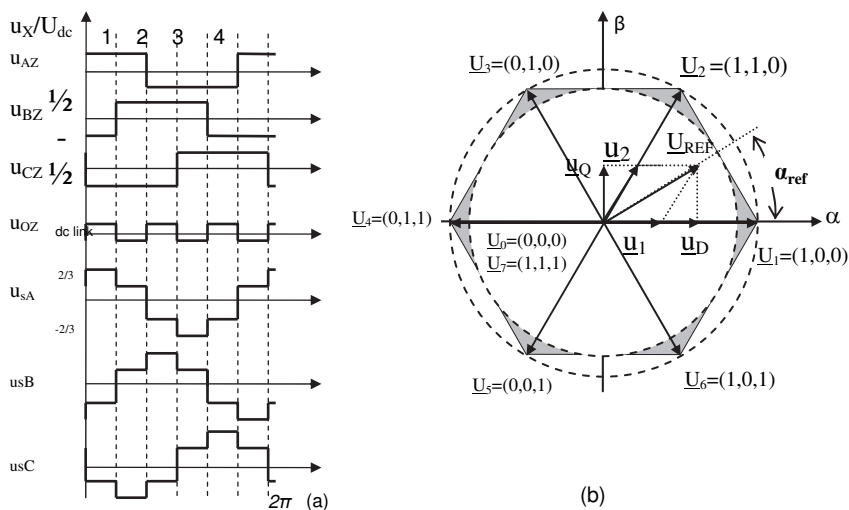

Fig. 8. a. Switched three-phase waveforms ; b. Switching state vectors

5. Control strategies

A number of control strategies can be used in a drive train for vehicles with different mission requirements. The control objectives of the hybrid electric vehicles are [Ehsani, 2005]: 1) to meet the power demand of the driver, 2) to operate each component of the vehicle with optimal efficiency, 3) to recover braking energy as much as possible, 4) to maintain the state-of-charge (SOC) of the battery in a preset window.

The induction motor drive on EV and HEV is supplied by a DC source (battery, fuel cell,) which has a constant terminal voltage, and a DC/AC inverter that provide a variable frequency and variable voltage . The DC/AC inverter is constituted by power electronic switches and power diodes.

As control strategies PWM control is used for DC motor, FOC (field-oriented control) and DTC (direct torque control) are used for induction motors. The control algorithms used are the classical control PID, but and the modern high-performance control techniques: adaptive control, fuzzy control, neuro network control [Seref 2010], [Ehsani 2005], [Livint et all 2008a, 2008c].

5.1 Structures for speed scalar control of induction motor

5.1.1 Voltage and frequency (Volts/Hz) control

Equation (11) indicates that the speed of an induction motor can be controlled by varying the supply frequency f_s . PWM inverters are available that can easily provide variable frequency supply with good quality output wave shape. The open loop volts/Hz control is therefore quite popular method of speed control for induction motor drives where high accuracy in control is not required. The frequency control also requires proportional control in applied voltage, because then the stator flux $\Psi_s = U_s / \omega_s$ (neglecting the resistance drop) remains constant. Otherwise, if frequency alone is controlled, then the flux will change.

When frequency is increased, the flux will decrease, and the torque developed by the motor will decrease as shown in Figure 9.a. When frequency is decreased, the flux will increase and may lead to the saturation of magnetic circuit. Since in PWM inverters the voltage and frequency can be controlled independently, these drives are fed from a PWM inverter.

The control scheme is simple as shown in Figure 9.b with motor being supplied by three-phase supply dc-link and PWM inverter.

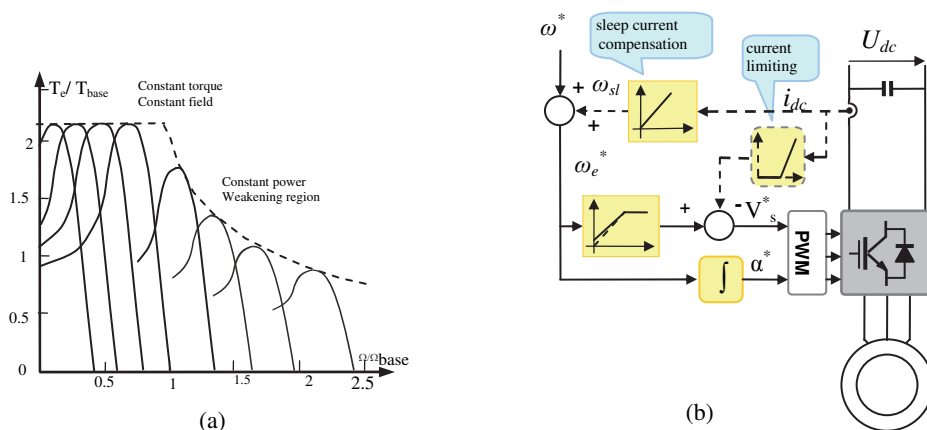

Fig. 9. a. Torque-speed characteristics under V/f control; b. VSI induction motor drive V/f controlled

The drive does not require any feedback and is used in low performance applications where precise speed control is not required. Depending on the desired speed the frequency command is applied to the inverter, and phase voltage command is directly generated from the frequency command by a gain factor, and input dc voltage of inverter is controlled.

The speed of the motor is not precisely controlled by this method as the frequency control only controls the synchronous speed [Emadi, 2005], [Livint et al. 2006] There will be a small variation in speed of the motor under load conditions. This variation is not much when the speed is high. When working at low speeds, the frequency is low, and if the voltage is also reduced then the performance of the motor are deteriorated due to large value of stator resistance drop. For low speed operation the relationship between voltage and frequency is given by

$$U_s = U_0 + kf_s \quad (15)$$

where U_0 is the voltage drop in the stator resistance.

5.2 Structures for speed vector control of induction motor

In order to obtain high performance, and fast dynamic response in induction motors, it is important to develop appropriate control schemes. In separately excited dc machine, fast transient response is obtained by maintaining the flux constant, and controlling the torque by controlling the armature current.

The vector control or *field oriented control* (FOC) of ac machines makes it possible to control ac motor in a manner similar to the control of a separately excited dc motor. In ac machines also, the torque is produced by the interaction of current and flux. But in induction motor the power is fed to the stator only, the current responsible for producing flux, and the current responsible for producing torque are not easily separable. The basic principle of vector control is to separate the components of stator current responsible for production of flux, and the torque. The vector control in ac machines is obtained by controlling the magnitude, frequency, and phase of stator current, by inverter control. Since, the control of the motor is obtained by controlling both magnitude and phase angle of the current, this method of control is given the name vector control.

In order to achieve independent control of flux and torque in induction machines, the stator (or rotor) flux linkages phasor is maintained constant in its magnitude and its phase is stationary with respect to current phasor .

The vector control structure can be classified in: 1. direct control structure, when the oriented flux position is determined with the flux sensors and 2. indirect control structure, then the oriented flux position is estimated using the measured rotor speed.

For indirect vector control, the induction machine will be represented in the synchronously rotating reference frame. For indirect vector control the control equations can be derived with the help of d-q model of the motor in synchronous reference frame as given in 13.

The block diagram of the rotor flux oriented control a VSI induction machine drive is presented in Figure 10.

Generally, a closed loop vector control scheme results in a complex control structure as it consists of the following components: 1. PID controller for motor flux and toque, 2. Current and/or voltage decoupling network, 3. Complex coordinate transformation, 4. Two axis to three axis transformation, 5. Voltage or current modulator , 6. Flux and torque estimator, 7. PID speed controller

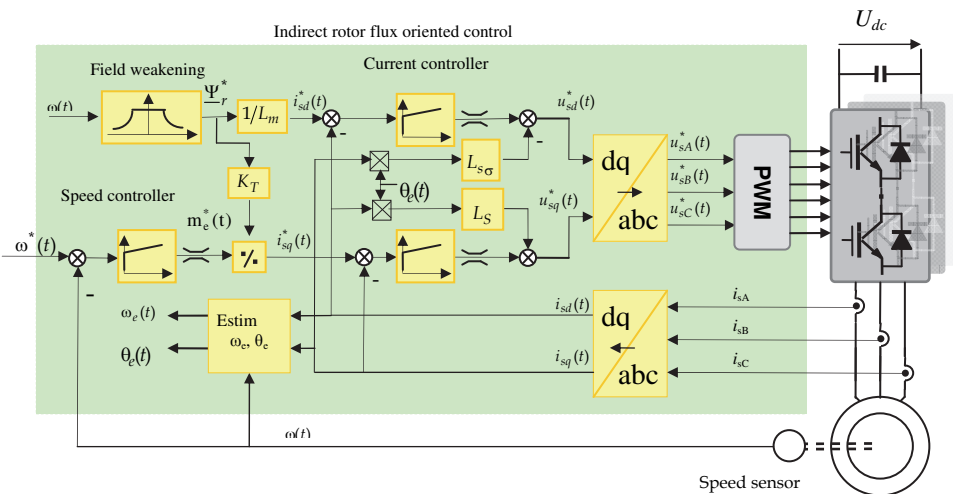

Fig. 10. Block diagram of the rotor flux oriented control of a VSI induction machine drive

6. Experimental model of hybrid electric vehicle

The structure of the experimental model of the hybrid vehicle is presented in Figure 11. The model includes the two power propulsion (ICE, and the electric motor/generator M/G) with allow the energetically optimization by implementing the real time control algorithms. The model has no wheels and the longitudinal characteristics emulation is realized with a corresponding load system. The ICE is a diesel F8Q of 1.9l capacity and 64[HP]. The electronic unit control (ECU) is a Lucas DCN R04080012J-80759M. The coupling with the motor/generator system is assured by a clutch, a gearbox and a belt transmission.

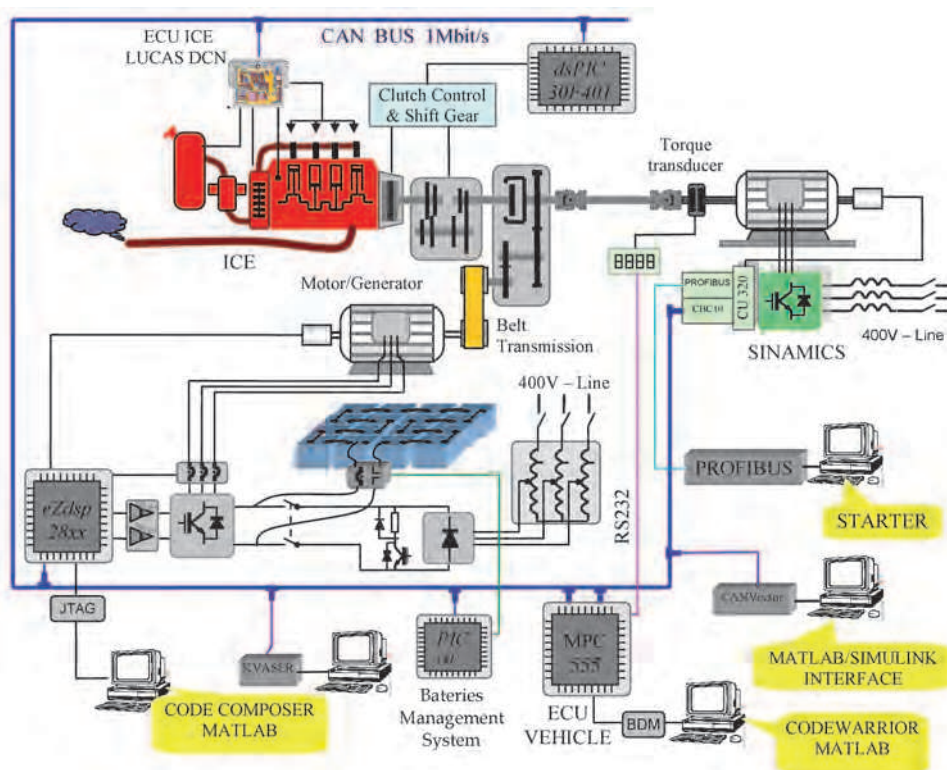

Fig. 11. The structure of the experimental model of the hybrid electric vehicle

The electric machine is a squirrel cage asynchronous machine (15kW, 380V, 30.5A, 50Hz, 2940 rpm) supplied by a PWM inverter implemented with IGBT modules (SKM200GB122D). The motor is supplied by 26 batteries (12V/45Ah). The hardware structure of the motor/generator system is presented in Figure 12. The hardware resources assured by the control system eZdsp 2808 permit the implementation of the local dynamic control algorithms and for a CAN communication network, necessary for the distributed control used on the hybrid electric vehicle, [Livint et al 2008, 2010]

With the peripheral elements (8 ePWM channels, 2x8 AD channels with a resolution of 12 bits, incremental transducer interface eQEP) and the specific peripheral for the

communication assure the necessary resources for the power converters command and for the signal acquisition in system. For the command and state signal conditioning it was designed and realized an interface module.

6.1 The emulation of the longitudinal dynamics characteristics of the vehicle

The longitudinal dynamics characteristics of the vehicle are emulated with an electric machine with torque control, Figure 13. As a mechanical load emulator, the electric machine operates both in motor and generator regimes. An asynchronous machine with vector control technique assures a good dynamic for torque. This asynchronous machine with parameters (15KW, 28.5A, 400V, 1460rpm) is supplied by a SINAMICS S120 converter from Siemens which contains a rectifier PWM, a voltage dc link and a PWM inverter [Siemens 2007]. This converter assures a sinusoidal current at the network interface and the possibility to recover into the network the electric energy given by the electric machine when it operates in generator regime.

The main objective is to emulate the static, dynamics and operating characteristics of the drive line. The power demand for the vehicle driving at a constant speed and on a flat road [Ehsani, 2005], can be expressed as

$$P_e = \frac{v}{1000\eta_{t,e}} (m_v g f_r + \frac{1}{2} \rho_a C_D A_f v^2 + m_v g i) \quad [kW] \quad (16)$$

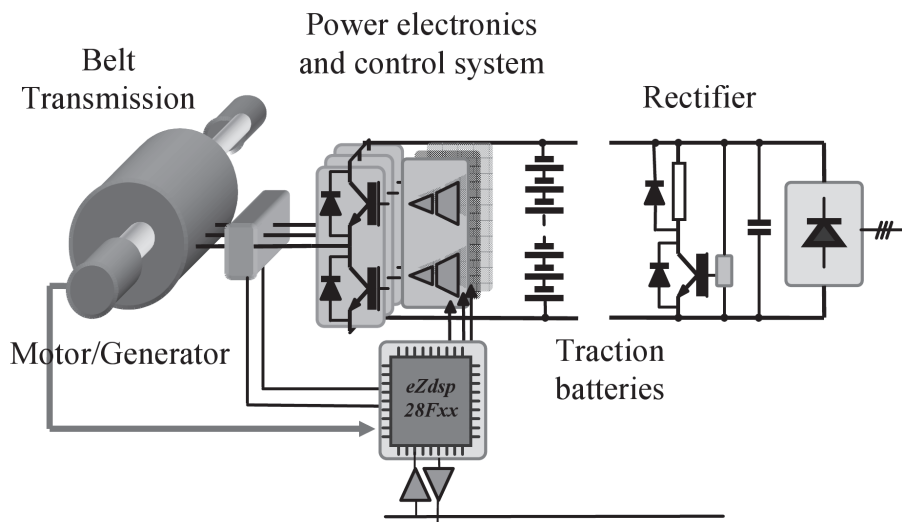

Fig. 12. Electric motor/generator system

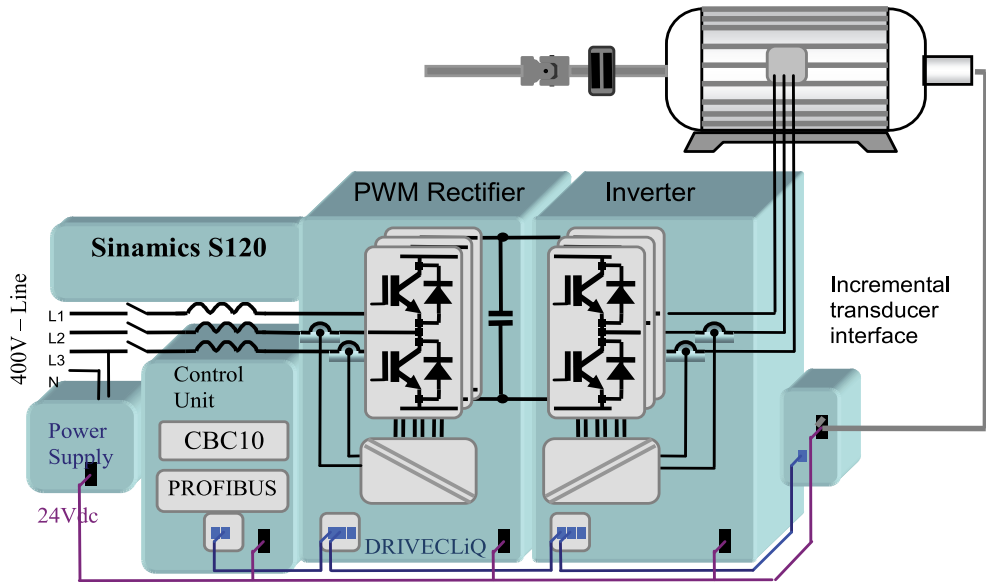

Fig. 13. Emulation system of the longitudinal dynamics characteristics of the vehicle

6.2 The distributed system of the real-time control of the hybrid electric vehicle model

The coordinated control of the sub-systems of the parallel hybrid vehicle can be realized with a hierarchical structure, [Livint et. al, 2006, 2008]. Its main element is the Electronic Control Unit vehicle of the vehicle (ECU vehicle) which supervises and coordinates the whole systems.

It has to monitor permanently the driver demands, the motion conditions and the state of the sub-systems in order to estimate the optimum topology of the whole system and to assure minimum fuel consumption at high running performances. The main system must to assure the maneuverability demanded by the driver in any running conditions. These supervising and coordinating tasks are realized by a control structure that includes both state automata elements and dynamic control elements corresponding to each state. The dynamic control of each sub-system is realized by every local control system. The dynamic control is integrated at the level of the coordinating system only when it is necessary a smooth transition between states or for a dynamic change into a state with more than a sub-system (starting engine with the electric machine).

The optimization of the performances objectives is realized logically by the state automata. The optimum operating state is determined by the coordinating and supervising system based on the analysis of the centralized data.

The state machine design is achieved in three stages:

- the identification of the all possible operating modes of the vehicle,
- the evaluation of the all possible transitions between the operating modes,
- the arbitration of the priorities between the concurrent transitions.

For the first stage it is realized a list with the possible operating modes for each sub-system. For example, for the engine the possible operating modes are running engine and stop engine.

After the identification of the all possible operating modes of each sub-system, it is generated a set of all the possible combinations of the operating modes for the vehicle.

Due to the complexity of the real time control for a parallel hybrid electric vehicle it is necessary to integrate all the elements in a high speed CAN communication network (1Mbps) to assure the distributed control of all resources [CANopen, 2004], [Chacko, 2005]. The experimental model uses a CANopen network with four slave nodes and one master node. The master node is implemented on phyCORE-mpc555 system and assures the network management and supervises the nodes control connected by NMT services, the nodes operating states, the emergency messages analysis and the modifications appeared into the communication network. The first CANopen slave node, at an inferior level, is dedicated for the motor/generator system and includes the speed control loop for the vehicle electrical propulsion. The second slave node is used to take over the torque data given on the RS-232 serial line by the DTR torque transducer and to convert the data for the proper utilization on the CANopen network.

The third slave node of the CANopen network is used for the emulation system for the longitudinal dynamics characteristics of the vehicle, implemented with the asynchronous motor and the SINAMICS S120 converter.

The fourth slave node of the CANopen network is the system of automatic gear shift, which involves control of clutch and gear. Control is achieved with a numerical dsPIC-30F4011.

The CAN protocol utilizes versatile message identifiers that can be mapped to specific control information categories. With predefined priority of the communication message, non-destructive bit-wise arbitration with error detection signaling, the CAN protocol supports distributed real-time control in vehicles applications with a very high level of security .

The content of a message is named by an *identifier*. The *identifier* describes the meaning of the data, but not indicates the destination of the message. All nodes in the network are able to decide by *message filtering* whether the data is to be accepted. If two or more nodes attempt to transmit at the same time, a non-destructive arbitration technique guarantees the messages transmission in order of priority and that no messages are lost.

It is guaranteed that a message is simultaneously accepted by all nodes of a CAN network. When a receiver detects an error in the last bit that cares about it will send an error frame and the transmitter will retransmit the message.

The CAN network provides standardized communication objects for real-time data (PDO – Process Data Objects), configuration data (SDO – Service Data objects), and special functions (Emergency message), network management data (NMT message, Error control).

Service Data Object (SDO) supports the mandatory OD (Object Dictionary) entries, slave support for the next slave services: Reset_Node, Enter_Preoperational_State, Start_Remote_Node, Stop_Remote_Node, Reset_Communication, COB (Communication Data Object).

For the software design it was in attention the modularity and a scalar structure of the final product that can be easy configured for the automation necessities of the communication node. For this the CANopen stack was structured in two modules [Livint et al, 2008, 2009]:

- Module I, dependent on the hardware resources of the numerical system,
- Module II, specific for the application, independent on the hardware resources. To pass the product on other numerical systems it is enough to rewrite the first module.

The functional structure of the slave CANOpen software is presented in Figure 14. Module I is specific for the numerical system (phyCORE-mpc555, eZdsp-F2808, dsPIC-30F4011) and module II is common all three systems. To implement the CANOpen protocol it was used both the graphical programming and the classic (textual) programming.

6.3 Module I implementation on the eZdsp-F2808 or dsPIC-30F4011 numerical systems

The Simulink model visible structure of the slave CANOpen communication node is presented in Figure 15.

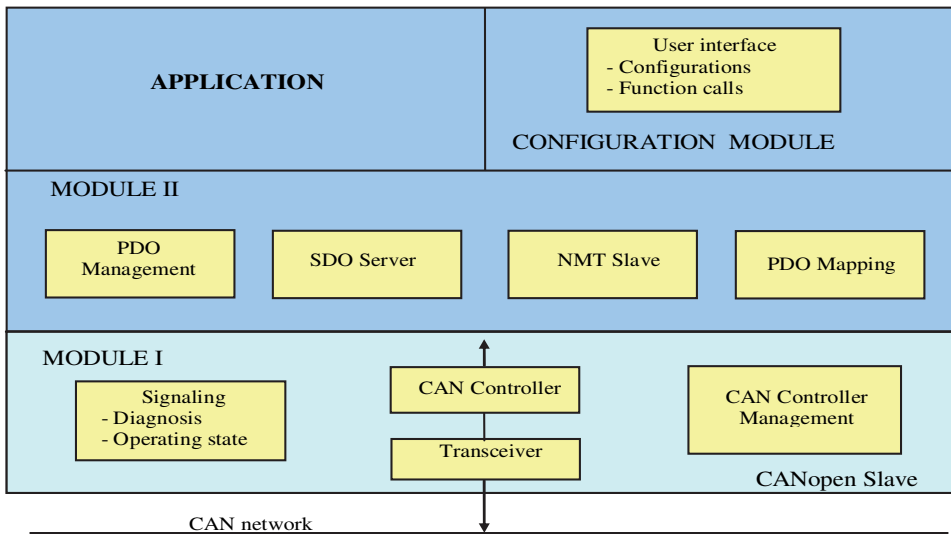

Fig. 14. The functional structure of a CANOpen slave

The CANOpen Message Receive (dsPIC30F4011 or eZdsp 2808) sub-system realizes the messages reception into the CANOpen stack buffer. The messages are transmitted by the CANOpen Message Send (dsPIC30F4011 or eZdsp 2808) sub-system.

They are part of the Module I from the Figure 16. In the same module there is also the CANOpen Err & Run LED's sub-system which commands the two LEDs of the numerical system. The stack initialization and its periodical interrogation are realized by the Init CANOpen, and SW_TimerISR sub-systems.

The data transfer between the graphical and textual modules is made with global variables which are defined by the state flow chart. It is to mention that was necessary to interfere with the C-code generating files (Target Language Compiler - TLC) to obtain the necessary functionality.

An important aspect of the CANOpen implementation is the generation of relative references of time to administrate the data transfer messages (timestamp) and the administrative data (node guarding, heartbeat). For this it was used a software which call both the CANOpen stack and the timer with 1 ms period.

Module I implementation on phyCORE-mpc555 numerical system

The Simulink model for the CANopen node of the second numerical system is similar with the model from Figure 17 but eZdsp 2808 is changed with phyCORE-mpc 555. Thus, for a user which knows a model it is easy to operate with the other. The communication speed is established with the MPC555 Resource Configuration module.

Module II implementation of slave CANopen communication node

The graphical programming is operative and suggestive. It also has limits especially for the complex algorithms processing. In this case the programmer makes a compromise: hardware resources are realized with the graphical libraries and the complex algorithms processing are implemented with textual code lines. The Matlab/Simulink embraces such a combined programming.

Thus, the second module was implemented by a textual programming. The function call is realized with a 1KHz frequency by the SW_TimerISR sub-system. SDO services are assured by the object dictionary SDOResponseTable and by the functions Search_OD (WORD index, BYTE subindex), Send_SDO_Abort (DWORD ErrorCode) and Handle_SDO_Request (BYTE*pData). The functions Prepare_TPDOs (void) and TransmitPDO (BYTE PDONr) realize the administration of the data transmission messages between the numerical systems

The node initialization is realized by the function CANOpen_Init (BYTE Node_ID, WORD Heartbeat) and the communication network administration (NMT slave) are incorporate into the function CANOpen_ProcessStack(void).

The connections (mapping) between the data on the CAN communication bus can be static realized by the initialization function CANOpen_InitRPDO (BYTE PDO_NR, WORD CAN_ID, BYTE len, BYTE *dat), CANOpen_InitTPDO (BYTE PDO_NR, WORD CAN_ID, WORD event_time, WORD inhibit_time, BYTE len, BYTE *pDat).

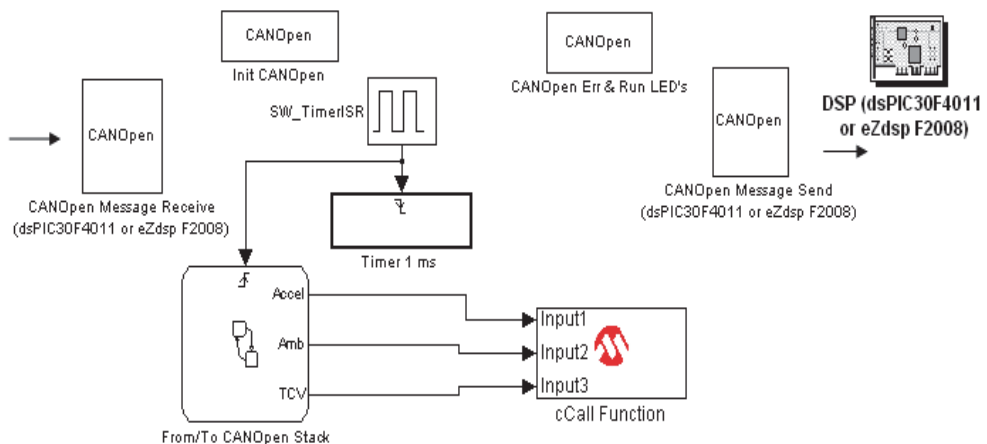

Fig. 15. The Simulink model assigned to the slave CANopen communication node

6.4 Experimental results

In Figure 16 is presented the hybrid electric vehicle model realized into the Energy Conversion and Motion Control laboratory of the Electrical Engineering Faculty from Iasi. Finally several diagrams are presented highlighting the behaviour of the electric traction motor and the mechanical load emulator. It was considered a standard operating cycle UDDS (Urban Dynamometer Driving Schedule).

A velocity diagram UDDS cycle operation is shown in Figure 17-a. It is the speed reference for electric traction motor and the measured speed is presented in Figure 17-b.

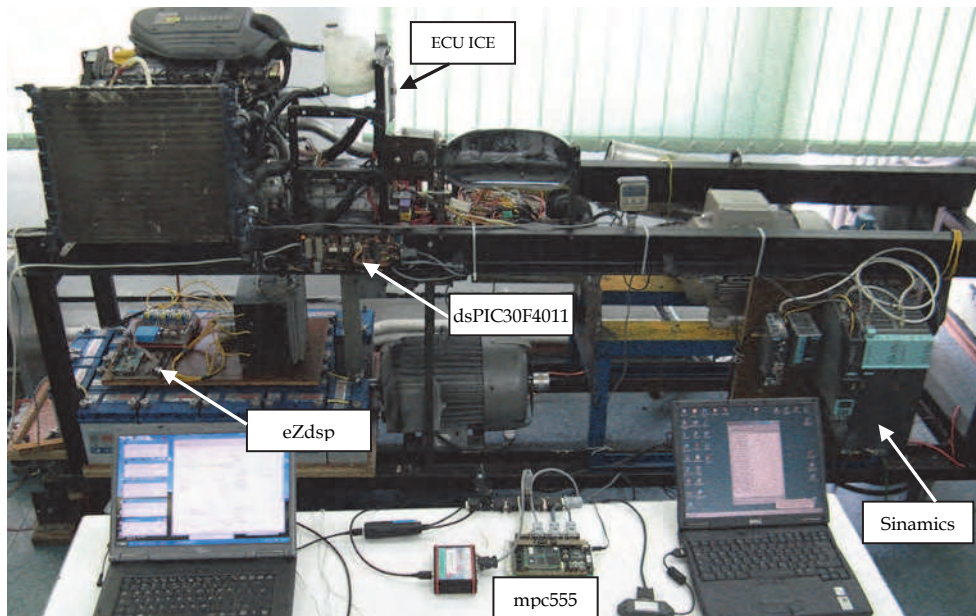

Fig. 16. Hybrid electric vehicle experimental model

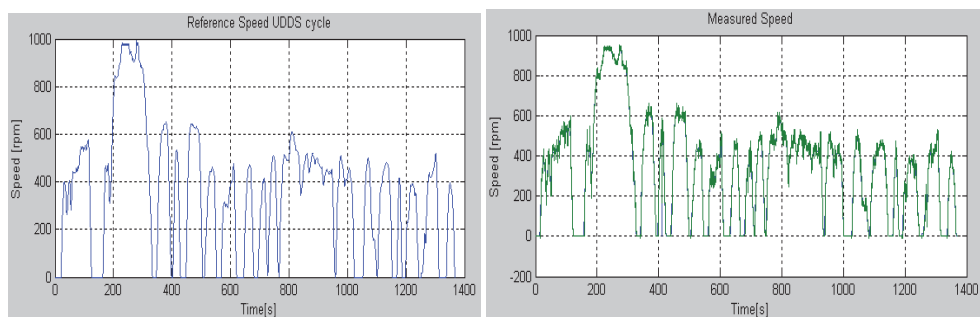

Fig. 17. a) Reference speed for UDSS cycle b) Measured speed for electrical motor

The active current from electrical traction motor is shown in Figure 18-a. Also the mechanical load emulator is an electrical motor with torque control and the torque reference shown in Figure 18-b. In Figure 19 is presented the estimated torque from mechanical load emulator.

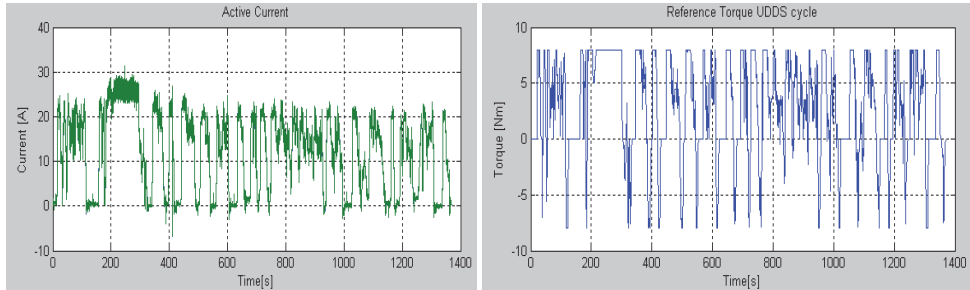

Fig. 18. a) The active current from electric traction motor b) The reference torque for Sinamics system

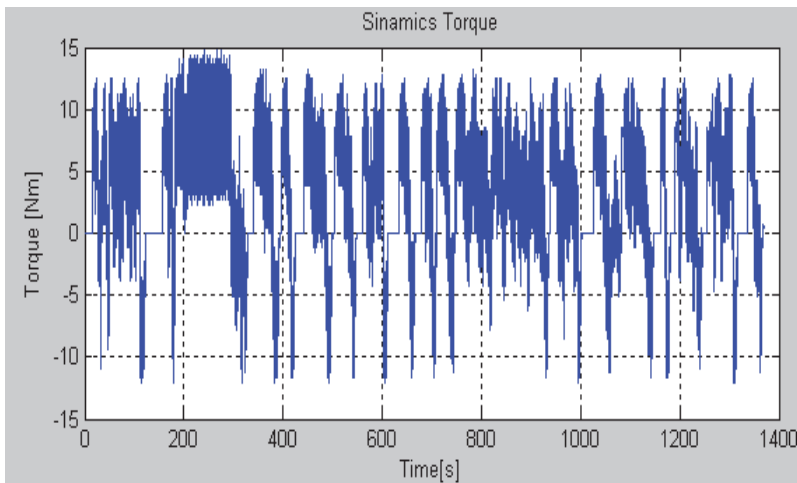

Fig. 19. The estimated torque from mechanical load emulator

7. Conclusions

The hybrid electric vehicles are very complex dynamic systems and have an important number of interconnected electrical systems to achieve the required operating performances. Because of the complexity of the real time control for a hybrid electric vehicle it is necessary to integrate all the elements in a high speed CAN communication network to assure the distributed control of all the resources. For the hybrid electric vehicle experimental model is used a CANopen network with one master node and four slave nodes. The distributed system control with the CANopen protocol on a CAN bus permits the control of the electrical drives systems in safe conditions and with improved dynamic performances.

8. References

- Bayindir , K. C., Gozukucuk, M.A., Teke, A. , (2011). A comprehensive overview of hybrid electric vehicle: Powertrain configurations, powertrain control techniques and electronic control units, *Energy Conversion and Management*, Elsevier, nr. 52, 1305-1313.
- CANopen, *User Manual, Software Manual*, (2004), PHYTE Technology Holding Company
- Chacko, V.R., Lahaparampil, V.Z., Chandrasekar, V., (2005). CAN based distributed real time controller implementation for hybrid electric vehicle, *IEEE*, 247- 251, ISBN 0-7803-9280-9-05
- Chan, C.C, (2002), The state of the art of electric and hybrid vehicles, *Proc. IEEE*, vol. 90, no. 2, pp. 247-275
- Comigan , S., (2002). *Introduction to the Controller Area Network (CAN)*, Texas Instruments Application Report, SLOA101-August 2002, pp. 1-16
- Duan, J., Xiao, J., Zhang, M., (2007). Framework of CANopen protocol for a hybrid electric vehicle, *Proceedings of the IEEE Intelligent Vehicles Symposium*, Istanbul, Turkey, June 13-15, 2007.
- Ehsani M., Gao Y., Gay E.S. Emadi A, (2005). *Modern Electric, Hybrid Electric, and Fuel Cell Vehicles* CRC PRESS, Boca Raton London, New York, ISBN 0-8493-3154-4
- Emadi Ali, (2005). *Handbook of Automotive power electronics and MotorDrives*, CRC PRESS, Taylor&Francis Group, LLC, 2005, ISBN 0-8247-2361-9
- Fuhs A.E., (2009). *Hybrid Vehicles*, CRC PRESS 2009, Taylor Francis Group, LLC, ISBN 978-1-4200-7534-2
- Guzzella L., Sciarretta A., (2007). *Vehicle Propulsion Systems*, Second Edition, Springer-Verlag Berlin Heidelberg, ISBN 978-3-540-74691-1
- Husain I., (2003), *Electric and Hybrid Vehicles Design Fundamentals*, CRC PRESS, ISBN 0-8493-1466-6
- Livint, Gh., Gaiginschi, R., Horga, V., Drosescu R., Chiriac, G., Albu, M., Ratoi, M., Damian, I, Petrescu M., (2006). *Vehicule electrice hibride*, Casa de Editura Venus, Iasi, Romania
- Livint, Gh., Răţoi, M., Horga, V., Albu, M, (2007). Estimation of Battery Parameters Based on Continuous-Time Model, *Proceedings International Symposium on Signals, Circuits&Systems-ISSCS* , July 12-13, 2007, Iasi, Romania, pp. 613-617, IE.EE. Catalog Number: 07EX1678C, ISBN: 1-4244-0969-1
- Livint Gh., Horga, V., Albu, M., Răţoi, M, (2007). Evaluation of Control Algorithms for Hybrid Electric Vehicles, *WSEAS TRANSACTIONS on SYSTEMS*, Issue 1, Vol. 6, January 2007, pp. 133-140, ISSN 1109-2777, <http://www.wseas.org>
- Livint, Gh., Horga, V., Ratoi, M., (2008), Distributed control system for a hybrid electric vehicle implemented with CANopen protocol, -Part I, *Bulletin of the Polytechnic Institute of Iasi*, Tom LIV (LVIII), FASC. 4, ISSN 1223-8139, pp. 1019-1026
- Livint, Gh., Horga, V., Ratoi, M., Albu, M., Petrescu, M., Chiriac, G., (2008). Distributed control system for a hybrid electric vehicle implemented with CANopen protocol-Part II, *Bulletin of the Polytechnic Institute of Iasi*, Tom LIV (LVIII), FASC. 4, ISSN 1223-8139, pp. 1027-1032
- Livint, Gh., Horga, V., Ratoi, M., Damian, I., Albu, M., Chiriac, G., (2008). Advanced real time control algorithms for hybrid electric vehicles optimization, *CEEX Program, Simposion "Contributii Stiintifice "*, UCP AMTRANS, Bucuresti, Romania, noiembrie 2008, pp. 209-214

- Livint, Gh., Horga, V., Ratoi, M., Albu, M., Chiriac, G., (2009), Implementing the CANopen protocol for distributed control for a hybrid electric vehicle, *Proceedings The 8th International Symposium on Advanced Electromechanical Motion Systems*, Lille , July 1-3, CD., ISBN: 978-2-915913-25-5/EAN: 978-2-91 5913-26-5 IEEEExplore, <http://ieeexplore.ieee.org/xpl/RecentCon.jsp?punumber=5234983>
- Livint, Gh., Horga, V., Sticea, D., Rațoi, M., Albu, M., (2009) Electrical drives control of a hybrid electric vehicle experimental model, *Proceedings of the 7th International Conference of Electromechanical and Power Systems*, Editura PIM, 2009, vol. II, pp. 21-27, ISBN vol II, 978-606-520-623-6, October 8-9, 2009, Iași, Romania,
- Livint Gh., Horga V., Sticea D., Rațoi M., Albu M., (2010). Hybrid electric vehicle experimental model with CAN network real time control, in *Advances in Electrical and Computer Engineering*, nr. 2., 2010, pp. 102-108, ISSN 1582-7445, Stefan cel Mare University of Suceava, Romania
- Petrescu, M., Livint, Gh., Lucache, D. (2008), Vehicles dynamic control using fuzzy logic, *Proceedings of 9th WSEAS International Conference on Automation and Information*, pag. 488-493, 2008
- Seref Soylyu, (2010) *Urban Transport and Hybrid Vehicles*, Published by Sciyo, Janeza Trdine 9, 51000 Rijeka, Croatia, ISBN 978-953-307-100-8
- Siemens, Sinamics, *S120 Control Unit and additional system components*, (2007), Equipment Manual 03, Edition
- Sticea D., Livint Gh., Albu M., Chiriac G., (2009). Experimental stand for the dynamical cycle study of the batteries used on hybrid electrical vehicle, *Proceedings of the 7th International Conference of Electromechanical and Power Systems*, Editura PIM, 2009, vol. II, pp. 172-175, ISBN vol II, 978-606-520-623-6, October 8-9, 2009, Iași, Romania,
- Yamada, E., and Zhao, Z., (2000). Applications of electrical machine for vehicle driving system, *Proceedings of the Power Electronics and Motion Control Conference (PIEMC)*, vol 3., pp. 1359-1364, Aug. 15-18, 2000.
- Westbrook H. M., (2005). *The Electric Car, Development and future of battery, hybrid and fuel-cell cars*, The Institution of Electrical Engineers, London, 2005, ISBN 0 85296 013 1
- Wyczalek, F.A., (2000) Hybrid electric vehicles year 2000, *Proceedings of the Energy Conversion Engineering Conference and Exhibit (IECEC) 35th Intersociety*, vol.1, pp. 349-355, July 24-28, 2000

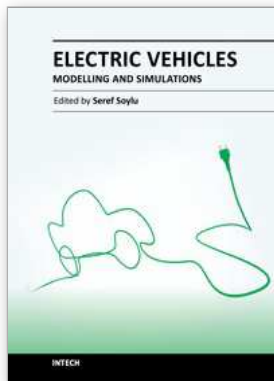

Electric Vehicles - Modelling and Simulations

Edited by Dr. Seref Soylu

ISBN 978-953-307-477-1

Hard cover, 466 pages

Publisher InTech

Published online 12, September, 2011

Published in print edition September, 2011

In this book, modeling and simulation of electric vehicles and their components have been emphasized chapter by chapter with valuable contribution of many researchers who work on both technical and regulatory sides of the field. Mathematical models for electrical vehicles and their components were introduced and merged together to make this book a guide for industry, academia and policy makers.

How to reference

In order to correctly reference this scholarly work, feel free to copy and paste the following:

Gheorghe Livinț, Vasile Horga, Marcel Rățoi and Mihai Albu (2011). Control of Hybrid Electrical Vehicles, Electric Vehicles - Modelling and Simulations, Dr. Seref Soylu (Ed.), ISBN: 978-953-307-477-1, InTech, Available from: <http://www.intechopen.com/books/electric-vehicles-modelling-and-simulations/control-of-hybrid-electrical-vehicles>

INTECH
open science | open minds

InTech Europe

University Campus STeP Ri
Slavka Krautzeka 83/A
51000 Rijeka, Croatia
Phone: +385 (51) 770 447
Fax: +385 (51) 686 166
www.intechopen.com

InTech China

Unit 405, Office Block, Hotel Equatorial Shanghai
No.65, Yan An Road (West), Shanghai, 200040, China
中国上海市延安西路65号上海国际贵都大饭店办公楼405单元
Phone: +86-21-62489820
Fax: +86-21-62489821

© 2011 The Author(s). Licensee IntechOpen. This chapter is distributed under the terms of the [Creative Commons Attribution-NonCommercial-ShareAlike-3.0 License](#), which permits use, distribution and reproduction for non-commercial purposes, provided the original is properly cited and derivative works building on this content are distributed under the same license.