

Mechanical Properties of New Ceramic Materials Obtained from Granular Solid Residuals Coming from Mines and Diatomaceous Earth

Jaime Vite-Torres, María del Carmen Carreño de León,
Manuel Vite-Torres and Juan Rodrigo Laguna-Camacho
*Instituto Nacional de Investigaciones Nucleares (ININ),
SEPI-ESIME-Campus Zacatenco-IPN,
Universidad Veracruzana, Campus Poza Rica, Veracruz
México*

1. Introduction

Granular solid residuals are produced by different industries in Mexico. Some of these are considered dangerous because they are stored in open areas contaminating and affecting the flora, fauna, and aquifers, and occasionally to the human being. These solid residuals coming from mines and diatomaceous earth are known as “jales” (náhuatl derived from xalli, it means sand). The “jales” have a high content of cyanide and heavy metals. These high contents are commonly out of the limits permitted by the Mexican standards. On the other hand, the “diatomita” (diatomaceous earth) is not as dangerous as the “jales”, however, this needs a treatment to eliminate the occluded organic material. This is normally used by producers of gelatin, antibiotics, industrial grease and oil, sugar refining, etc.

The leaching process of metals using the sodium cyanide was introduced in 1887 (Li, 1993). This revolutionizes the techniques to obtain gold and silver. This is a method usually employed in the world to recover metals. Two international patents were obtained by developing equipment and also a process to extract toxic metals and wastes from foundry sands (Vite, 1994a, 1994b). In addition, a national patent was achieved by the leaching of heavy metals from foundry sands (Vite, 1997).

Approximately, 330,000 tons of these solid residuals are generated daily in Mexico. In some states, such as Guanajuato, Zacatecas and cities as Pachuca in the state of Hidalgo, the waste deposits are found in open areas. The chemical composition of these solid residuals is varied. Figure 1 shows a photograph of the pipe used to transport the solid residuals until a “jales” dam.

An important case is related to “jales” when they have high pyrite content (FeS_2). This affects considerably the chemical composition due to their weathering. Due to this fact, it is necessary to process the “jales” before being used at applications such as the construction of landfills in the leveling of roads, additives for asphalt mixtures or dam construction (Botz & Stevenson, 1995, Orozco & Orozco, 1992, Sengupta, 1993, Vite et al., 2003, Wills, 1994).

In this study, a multidisciplinary work combining different mechanical, chemical and physical aspects was conducted. Industrial solid residuals coming from mines were leached to eliminate the toxic metals present in their chemical matrix. This process was carried out by using special equipment as mentioned and described above. It was developed and patented in Mexico and United States of America. The resultant solid material was mixed with solid residuals coming from diatomaceous earth and mines, and binders were employed to obtain new compact ceramic materials.



Fig. 1. Pipe used to transport the solid residuals until the jales dam

The mechanical properties of these ceramic materials, such as the compressive strength were determined in accordance to ASTM C170-50 and ASTM C-36 standard. The final results showed that these ceramic materials are lighter and exhibit higher compression strength than conventional materials such as bricks.

1.1 Background of the invention

The invention refers to an apparatus and process for extracting metals from foundry sands and, more specifically, to an apparatus and process for extracting these metals by making use of a thermostated column.

In the field of metal extraction based on foundry sands, the extraction techniques most utilized to date in a liquid-solid system involve mechanically-stirred leaching tanks, the Pachuca (State of Mexico) tank and Bonotto, Kennedy or Rotocel extractors. None of this equipment however has been specifically designed to extract small quantities of metals from foundry sands, which represents a problem not, so far, resolved.

Of the conventional apparatus mentioned above, the Pachuca tank is that which most resembles the apparatus object of the present application. However, the thermostated column of the new apparatus differs from the Pachuca tank insofar as regards its air dispersion system, the use of decarbonated and humidified air, because it consists of a heating jacket and because temperature control of the heating fluid is by means of a thermostat. These features of an apparatus which is desired to protect, allow a suitable pulp suspension, prevent the formation of a silicate and carbonate layer at the bottom of the

column, permit better temperature control and a finer control of the process variables, such as the pH, the air flow and the solution's oxidation-reduction potential.

1.2 Summary of the apparatus

The apparatus and the process of the present invention allow low concentrations of the metals contained in the mining tailings to be simultaneously extracted, thus achieving two main goals which are 1) the recovery of metal values which can be recycled and 2) An important reduction in the toxicity of the industrial solid wastes (Mining Tailings) which once treated, can be handled as normal industrial waste, which can be used to make ceramic materials or construction materials, with important savings. From among the metals which are possible to recover, one can mention, among others platinum, gold, cobalt, germanium, zinc, manganese, silver and cooper, metals with many industrial uses, and some others such as chromium, vanadium and arsenic, which are highly toxic. Figure 2 shows a schematic diagram of the patented equipment ((Vite, 1994a, 1994b).

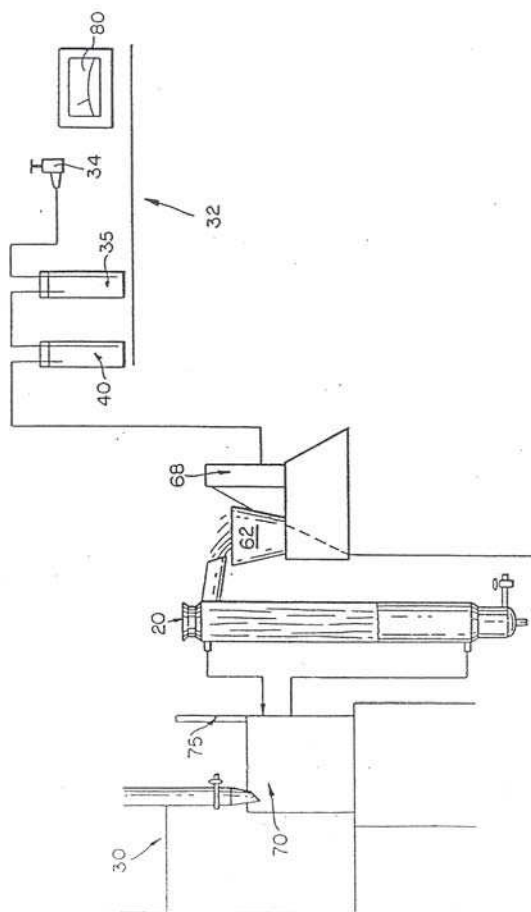

Fig. 2. Schematic diagram of the patented equipment (Vite, 1994a, 1994b)

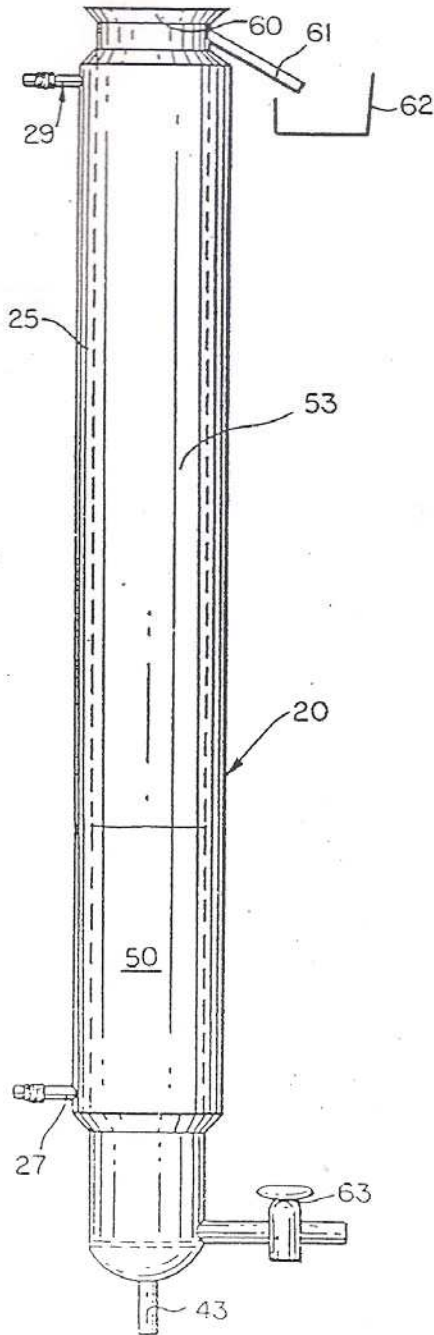

Fig. 3. Side view of the thermostated column (Vite, 1994a, 1994b)

In order to achieve its purpose, the apparatus consists of a thermostatic includes column which is connected to a decarbonated and humidified air supply source, and with a controlled heating system. This column includes an inlet for introduction of the components to form an aqueous pulp, and device for sparging, it in such away that a suitable suspension and homogenization of same is obtained. For it's part , the process is characterized by the introduction into the column of some reagents, distilled water and industrial solid wastes (mining tailings) in order to form an aqueous pulp which is processed in same for 2 hours under controlled temperature , air flow and pH conditions. Upon termination of the above mentioned period, the pulp in the column is extracted and once again heated for 20 minutes, after which it is filtered in order to obtain liquor with the metals in solution.

Another distinctive characteristic of this process is that, as distinguished from the existing system, it permits the extraction of metals from metallic alloys; the thermodynamic stability is higher than covalent bonds.

1.3 Detailed description of the invention

In the structural aspect of the invention (Figure 2, 3, 4 and 5) this consists of an apparatus comprising a thermostated column 20 having a double wall defining a heating jacket 25 through which a heating fluid circulates coming from a heating system 30 which is in flow communications with said jacket by means of the heating fluid inlet and outlet means 27, 29 disposed in element 25 for connection with said system 30. The purpose of said heating system is to maintain the interior of the column 20 at an approximate temperature of 60° C., in accordance with one of the variables of the process for extracting metals from foundry sands. To this end, the heating system 30 includes thermal control devices such as a thermostat 70 and thermometer 75 to control the temperature of the heating fluid.

The apparatus also includes a source 32 of supply of air to the column, where said source comprises a valve 34 for the admission of air and a carbonating device 35 and humidifier 40, the latter two placed in the path which communicates said source with de column. The air is passed through the device 35 and humidifier 40 before it reach the column, to which it is introduced by an inlet 43 and crosses to a sparging device 45 placed next to said inlet which server to finely divide the air in order to foster suitable suspension and homogenization of the pulp. Device 45 consist of a membrane with multiple orifices 46 of a diameter such as not to allow the pulp to pass through same towards the airflow inlet 43. The upper end of the column 20 includes an opening 48 through which the different components forming the aqueous pulp 50 are introduced, said pulp containing the metals which it is desired to extract in accordance with the aim of the apparatus and process invented. Pulp 50 is placed in the inner chamber 53 of the column, which has been previously heated by the heating system 30 and supplied with air from supply source 32, with the characteristics mentioned hereinabove, wherein said pulp is sparged by the air flow crossing device 45 in order to provide it with the suspension and homogenization properties required for the process. A frosted glass cap 60 is placed in opening 48 in order to avoid the escape of air and foam. However, the column is provided with means 61 through which the foam may leave into a reservoir 62. For extracting samples from the pulp during the process, the column has a valve 63, through which the necessary samples are taken to verify that the pulp being processed retains the ideal conditions for obtaining the desired results. In addition, a device 68 for controlling and measuring the airflow supplied to the column is located at a point

before the air inlet 43. With regard to the process the tailings are analyzed in order to verify their compatibility with said process and in order to subsequently carry out the corresponding metallurgic balances. Once analyzed the tailings are finely ground and suspended in an aqueous pulp with a solid-liquid ratio of 1 to 4 and the necessary reagents added; that from 10 to 40 g, of a mineral acid in order to reach a pH of 2, from 4 to 15 of a compound of the family of the bisulphites and from 0.3 to 1.5 g of mono and dialkylamines amineoxides and ethoxylated alkyl amines, all these reagents being of analytical grade. The addition of surfactant is preferred because it is a cationic surfactant which reduces the surface tension and promotes foam formation, thus obtaining a greater efficiency in the leaching process.

Figure 3 and 4 displayed a side view of the thermostated column and the membrane device of the column, respectively. Additionally, Figure 5 shows a design of diagram of a preliminary pilot plant for leaching metal values and toxic metals from industrial solid wastes. Finally, Figure 6 presents a block diagram of the process for the extraction of metal values from foundry sands.

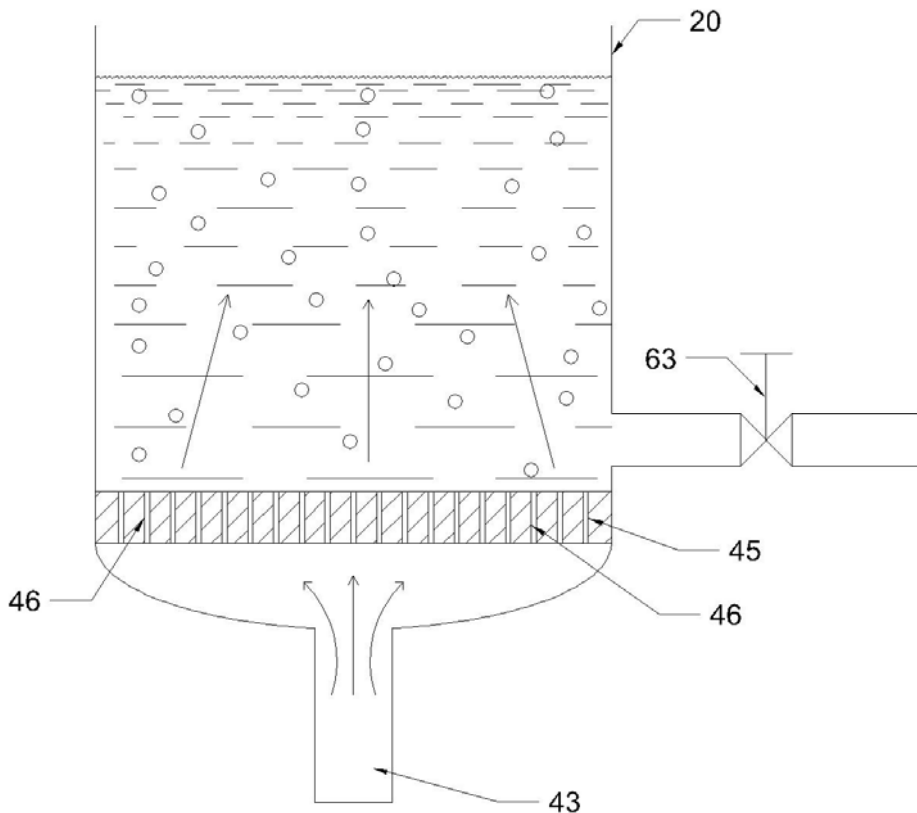

Fig. 4. Membrane device of the column (Vite, 1994a, 1994b)

2. Experimental details

2.1 Preparation of granular solid industrial residuals

2.1.1 Treatment of granular solid industrial residuals coming from diatomaceous earth

The diatomite (diatomaceous earth) is a marine sedimentary rock. This can be found in lake deposits and consist mainly of the accumulation of shells or hydrated silica secreted by diatoms which are microscopic organisms. Chemically consists of silicon dioxide (SiO_2), which is essentially inert; is attacked only by strong alkalis and hydrofluoric acid. Other components of the diatomite are: Sand, clay, volcanic ashes, magnesium carbonate, soluble salts and organic matter. The types and amounts of impurities are highly variable and depend on the conditions of sedimentation and deposition time of the diatomite. Diatomite is used primarily as filters, insulation or filler material. In the first case, the substance is used to filter sludge. Another application is in sugar refining and industrial plants in various solvents antibiotics, grass and oils. In many other cases diatomaceous earth are used for separation process. The diatomite is contaminated with organic material, after being used in the processes described above.

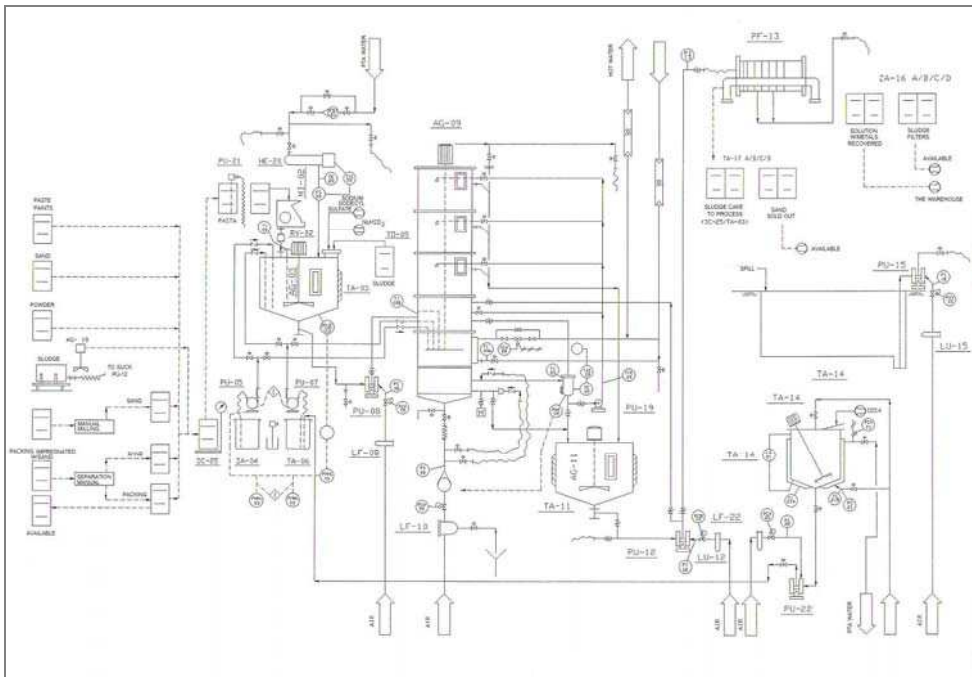

Fig. 5. Design plant for leaching of metal for values and toxic metals from industrial solidwastes (Vite, 1994a, 1994b)

In the laboratory, the organic material adhered to the diatomaceous earth was removed by a physical-chemical process developed here, thus obtaining innocuous material. Subsequently, the sample was sieved to achieve a grain size between 100-200 μm , likewise, a representative sample was taken, using the counting method and quartering, to analyze

qualitatively and quantitatively. Figure 7 shows the morphology of one of the samples obtained from granular solid industrial wastes coming from diatomaceous earth.

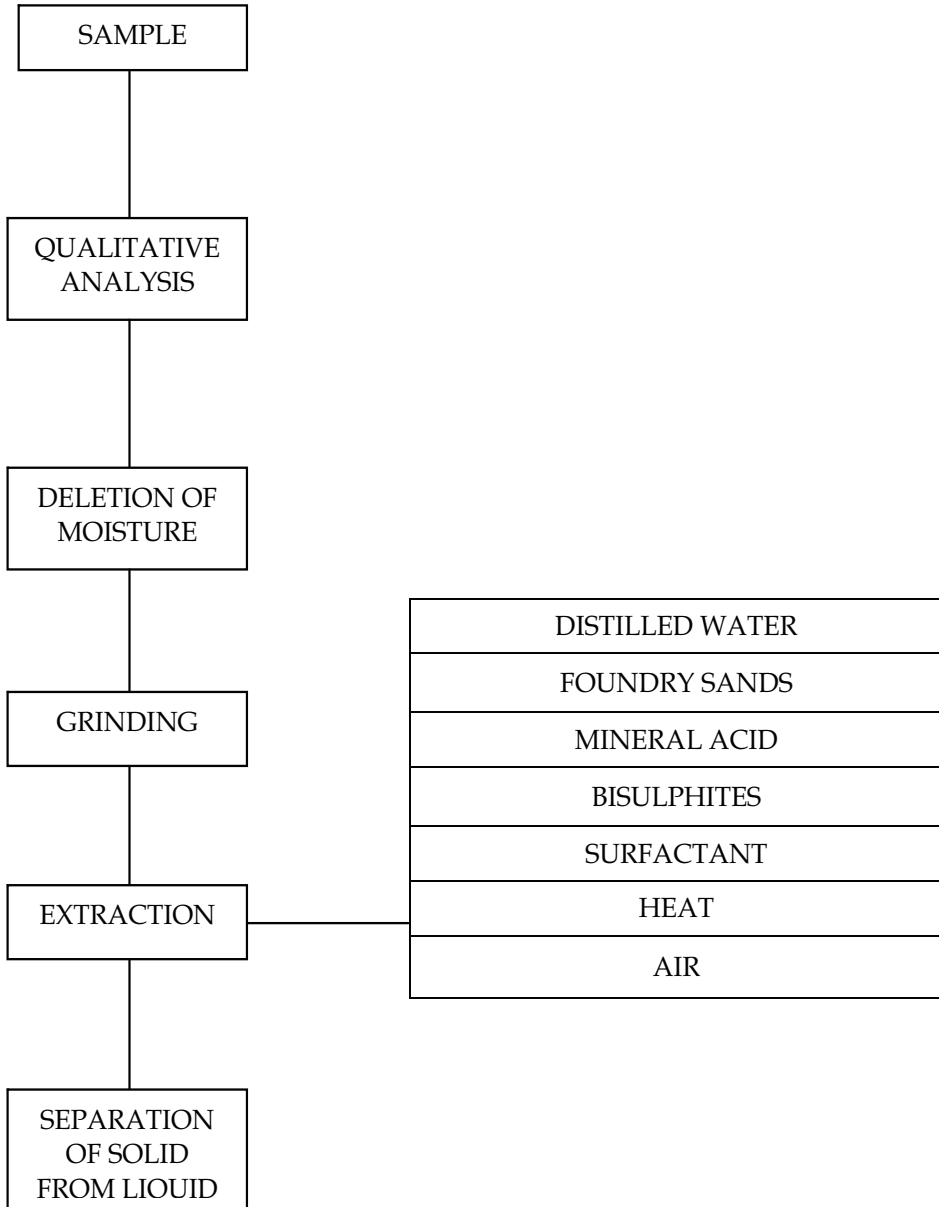

Fig. 6. Block diagram of the process for the extraction of metal values from foundry sands (Vite, 1994a, 1994b)

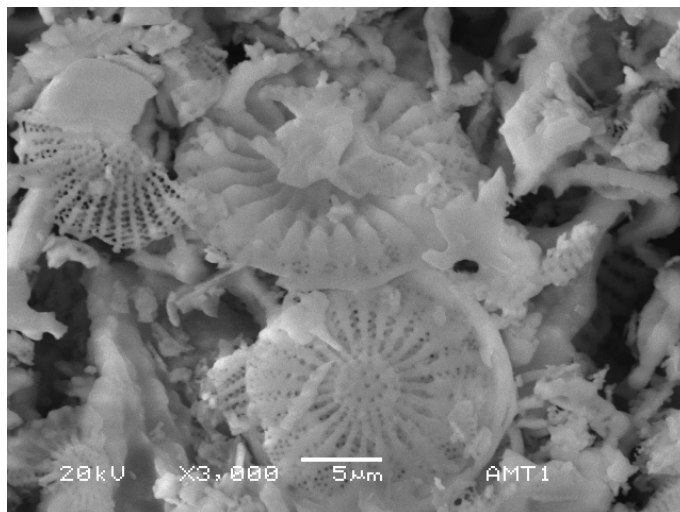

Fig. 7. Morphology characteristics of industrial residual coming from diatomaceous earth

2.1.2 Treatment of the mining industrial residuals samples (MIR)

To determine the presence and concentration of cyanide and heavy metals, representative samples were analyzed qualitative and quantitatively using conventional and nuclear techniques. Then, the content of cyanide was removed using thermostated coupled columns. This process and the equipment was developed and patented in the United States and Mexico (Vite, 1994a, 1994b). Samples are placed into the equipment, where sodium hypochlorite is added, the temperature in the columns is set at 28 ° C, during 20 min. Once the process is completed, the separation solid-liquid is performed. Then, the solid sample is dried and placed back in the thermostated coupled columns in order to leach heavy metals. The sample of "jales" is mixed with reducers, surfactants and complexing agents to perform the leaching process at different pH. Then, an acid or a base is added, la pulp is stirred by injecting air and each sample is processed for 120 min. at 60 ° C. After all this process, the solid-liquid separation is made. The solid was sieved to obtain a grain size between 100-200 μm and was analyzed qualitative and quantitatively, in order to verify the decrease in the concentration of cyanide and heavy metals content in the samples, if there is any evidence of a toxic component, the operation is repeated until obtain innocuous samples. The treatment of solid residuals to leach cyanide and heavy metals was successful, as it eliminates 100% of the cyanide content, as well as 80-100% of the heavy metals content occluded in the chemical matrix of the sample.

2.2 Specimens

The materials used to conduct the tests were ceramic materials identified as "JADIAR" due to a mixture of Jale-Diatomaceous earth-Clay. The samples were named as 1A, 1B and 1C. In the sample 1A, 50% was material coming from diatomaceous earth, 40% of mining industrial residual (Jale) and 10% clay. In sample 1B, was used 50% of diatomaceous earth, 30% solid residual (jale) and 20% clay. Finally, in sample 1C, the contents were 50% diatomaceous earth, 20% mining industrial residuals and 30% clay. Table 1 presents the

material contents. Each sample was mixed separately and was heat-treated first to remove moisture in an oven at a temperature of 100°C for 120 min., then the sample was treated in an oven at 950 °C for 180 min. The diagram shown in Figure 8, presents a flow chart of processing of materials coming from mining industrial residuals and diatomaceous earth.

Sample	Diatomaceous earth (%)	Mining industrial residuals (jales) (%)	Clay (%)
1A	50	40	10
1B	50	30	20
1C	50	20	30

Table 1. Material contents

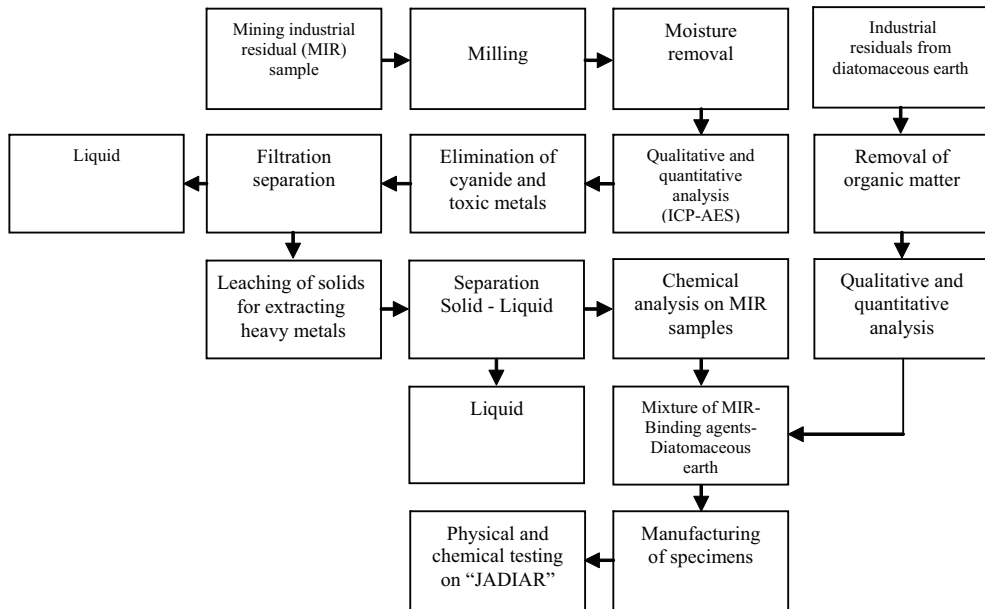

Fig. 8. Flowchart of processing of materials

3. Results and discussion

3.1 Methodology for the production of construction materials (lattice and bricks)

The main objectives pursued with these building blocks are: Ease of construction, increased insulation and ease of operation. Light inert materials are generally chosen. The manufacture may be carried out by mortars and concretes conveniently dispensed with fluid consistencies, paste or dried, depending on the system followed and the shape of the final piece.

3.1.1 Pasta preparation

Pastas are prepared from the mixture of granular solid industrial residuals coming from mines and diatomaceous earth with binding agents such as cement or clay mixed with water conveniently without exceeding their plasticity.

3.1.2 Molding

The molding is made by direct compression or by vibration, with mortar or concrete, the materials has to be practically dry, if the process is done by casting, the material must be more or less fluid. The procedures may be manual or mechanical, depending on the production, cost and product quality.

In this particular case, the manual procedure was used because the pieces were made solely for laboratory analysis. Metallic and Wood molds were used for the lattices. The results of the materials obtained using the methodology mentioned above, can be seen in the bricks and lattices in Figure 9 and Figure 10 where it is possible to observe the manufactured samples for tribological tests.



Fig. 9. Bricks and lattices obtained from granular solid residuals coming from diatomaceous, mining industrial residuals and binders

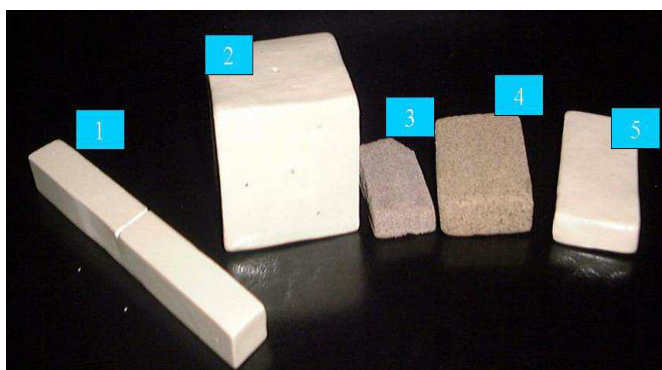

Fig. 10. Manufactured samples with clay and materials coming from mines and diatomaceous earth, 1) Impact and flexion testing, 2) Compression testing, 3) Erosive wear tests (Vite et al., 2010) 4) wet abrasion tests, 5) dry abrasion tests (Vite et al., 2011)

These bricks and lattices were obtained from solid industrial residuals coming from diatomaceous earth, which were mixed with mining industrial residuals and clay. These materials duplicate in tensile strength compared to conventional bricks, according to NOM-C-101, also, the percentage of absorption in the material obtained is smaller (about 17.1%) than required by the NOM-C-101, whose maximum value is 25%.

Note: It should be mentioned in the case of the lattice there are no regulations that specify the quality requirements to be met. The procedure for manufacturing was based on the proportions of the materials that give to a brick, the optimal resistance conditions.

3.2 Mechanical testing

3.2.1 Compressive strength according to ASTM C-170-50 and ASTM C-36

Compression tests are required to subject the sample to a compressive load, until it breaks or fractures. These can be made on most materials according to ASTM C-170-50 standard. The compression tests are conducted on materials such as cement, concrete, rubber, wood, plastic and clay (ceramics). This test consists of applying a variable vertical load to the material, in order to determine whether it complies or not the preset compressive load according to the type of the material studied. The manufacture of these materials can be carried out by mortars and concretes conveniently dispensed. The samples tested were named as 1A, 1B and 1C as mentioned previously. The dimensions of the test samples were 50.8 X 50.8 mm (a 2 inch cube). Figure 11 shows that the compressive strength of the samples analyzed had a maximum when the content of the binder agent was 30% in volume and such resistance was 160.3 kg/cm² and a minimum of 119.7 kg/cm² was obtained when the binder content was 10%. In both cases, the resistance was higher than that of a conventional brick whose resistance varies between 80-100 Kg/cm², also, the weight of the material obtained was 20-25% lower than the weight of conventional bricks, had less porosity and for this reason these materials were considered as a sustainable because the costs of processing were 25% lower, that the materials available on the market. Table 2 presents the compressive strength results for each testing sample.

The parameters obtained were:

- σ max - Maximum stress
- σ yield - Yield stress
- E - Young Modulus
- ϵ max - Maximum strain

Sample	Binder agent (%)	σ max (Kg/cm ²)	σ yield	E	ϵ max (%)
1A	10	119.7	-----	-----	2.7
1B	20	151.9	-----	-----	2.5
1C	30	160.3	-----	-----	3.0

Table 2. Mechanical test results

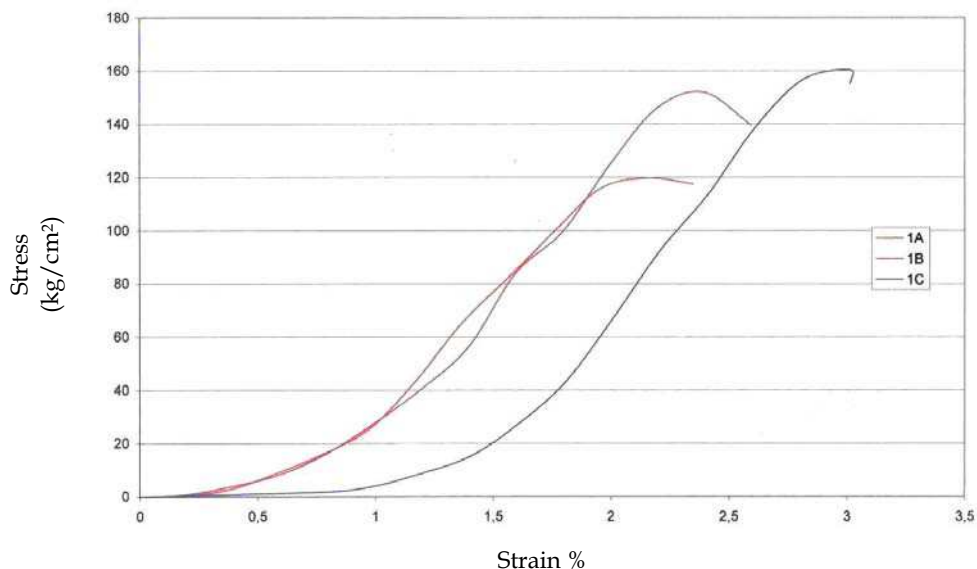

Fig. 11. Graph of the compressive resistance of test samples 1A, 1B and 1C

There are a variety of granular solid industrial residuals in all industrial countries, of anthropogenic origin and produced by nature, with which it is possible to generate proposals based on technical feasibility, economic and social development for the implementation of processes that help to the production of ceramic materials [10] or inputs for the construction industry. Due to this fact, the use of the patented equipment and the process employed in this work can provide sustainable economic and environmental benefits.

The management and implementation of solid and semisolid industrial residuals coming from different industrial sectors is important because it is possible to recover its usability by incorporating the production cycle as materials applicable to the construction industry. In addition, the impact to the environment and health of the population caused by proper handling of industrial solid residuals, which are often stored in open areas and dispersed by wind and rainwater.

4. Conclusions

Using thermostated columns can completely remove the cyanide content of "Jales" present in a recent process. After this treatment, the solid material is dried, characterized and processed with a binder agent, the final result provides a material with excellent mechanical properties for application in construction industries.

The bricks obtained had excellent physical and mechanical properties, such as greater resistance to compression than conventional bricks.

The materials obtained are 20-25% lighter than conventional materials, are also less porous and are sustainable, because development costs are 25% lower compared to other materials used in the construction industry.

There is a wide variety of possibilities of using solid residuals coming from mining and granular residuals from diatomaceous earth to be applied in the construction industry or to the development of ceramic materials.

5. References

- Botz, M., Stevenson, J. (1995). Cyanide Recovery and Destruction. *Engineering and Mining Journal.*, Vol.196, pp. 44-47, ISSN 0095-8948.
- Li, J., Wadsworth, E.M. (1993). Indirect Manipulation of a Sphere on a Flat Disk Using Force Information. *J. Electrochemical Soc.*, Vol.140, No.7, pp. 1921-1927, ISSN 0013-4651.
- Orozco, R.V., Orozco, Y.Y. (1992). Las Presas de Jales en México, Criterios Básicos para su Proyecto, Construcción y Operación, XVI Reunión Nacional de Mecánica de Suelos, México, 1992.
- Sengupta, M. (1993). *Environmental Impacts of Mining: Monitoring, Restoration and Control*, Lewis Publishers, ISBN 0873714415, United States of America.
- Vite, J. (1994a). Apparatus for Extracting Metal Values from Foundry Sands. U.S. Patent 5376000.
- Vite, J. (1994b). Process for Extracting Metal Values from Foundry Sands. U.S. Patent 5376001.
- Vite, J. (1997). Aparato para extraer Metales Valiosos de Arenas de Fundición. Mexican Patent 186702.
- Vite, J., Vite, M., Castillo, M., Laguna-Camacho, J.R., Soto, J., Susarrey, O. (2010). Erosive wear on ceramic materials obtained from solid residuals and volcanic ashes. *Tribology International*, Vol.43, pp. 1943-1950, ISSN 0301-679X.
- Vite, M., Vite, J., Laguna-Camacho, J.R., Castillo, M., Marquina-Chávez, A. (2011). Abrasive wear on ceramic materials obtained from solid residuals coming from mines. *Wear*, Article in press, ISSN 0043-1648.
- Vite-Torres, J., Díaz-Calva, A., Vite-Torres, M., Carreño de León, C. (2003). Application of Coupled Thermostated Columns in Civil Engineering and for Leaching Heavy Metals of Wastes from Foundry Sands and Mining. *International Journal of Environment and Pollution*, Vol.19, No. 1, pp. 46-65, ISSN 0957-4352.
- Wills, B. (1994). *Tecnología del Procesamiento de Minerales*, Editorial Limusa, México.

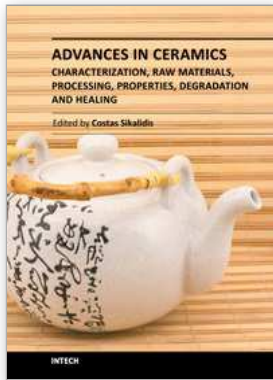

**Advances in Ceramics - Characterization, Raw Materials,
Processing, Properties, Degradation and Healing**

Edited by Prof. Costas Sikalidis

ISBN 978-953-307-504-4

Hard cover, 370 pages

Publisher InTech

Published online 01, August, 2011

Published in print edition August, 2011

The current book consists of eighteen chapters divided into three sections. Section I includes nine topics in characterization techniques and evaluation of advanced ceramics dealing with newly developed photothermal, ultrasonic and ion sputtering techniques, the neutron irradiation and the properties of ceramics, the existence of a polytypic multi-structured boron carbide, the oxygen isotope exchange between gases and nanoscale oxides and the evaluation of perovskite structures ceramics for sensors and ultrasonic applications. Section II includes six topics in raw materials, processes and mechanical and other properties of conventional and advanced ceramic materials, dealing with the evaluation of local raw materials and various types and forms of wastes for ceramics production, the effect of production parameters on ceramic properties, the evaluation of dental ceramics through application parameters and the reinforcement of ceramics by fibers. Section III, includes three topics in degradation, aging and healing of ceramic materials, dealing with the effect of granite waste addition on artificial and natural degradation bricks, the effect of aging, micro-voids, and self-healing on mechanical properties of glass ceramics and the crack-healing ability of structural ceramics.

How to reference

In order to correctly reference this scholarly work, feel free to copy and paste the following:

Jaime Vite-Torres, María del Carmen Carreño de León, Manuel Vite-Torres and Juan Rodrigo Laguna-Camacho (2011). Mechanical Properties of New Ceramic Materials Obtained from Granular Solid Residuals Coming from Mines and Diatomaceous Earth, *Advances in Ceramics - Characterization, Raw Materials, Processing, Properties, Degradation and Healing*, Prof. Costas Sikalidis (Ed.), ISBN: 978-953-307-504-4, InTech, Available from: <http://www.intechopen.com/books/advances-in-ceramics-characterization-raw-materials-processing-properties-degradation-and-healing/mechanical-properties-of-new-ceramic-materials-obtained-from-granular-solid-residuals-coming-from-mi>

INTECH
open science | open minds

InTech Europe

University Campus STeP Ri
Slavka Krautzeka 83/A
51000 Rijeka, Croatia
Phone: +385 (51) 770 447
Fax: +385 (51) 686 166

InTech China

Unit 405, Office Block, Hotel Equatorial Shanghai
No.65, Yan An Road (West), Shanghai, 200040, China
中国上海市延安西路65号上海国际贵都大饭店办公楼405单元
Phone: +86-21-62489820
Fax: +86-21-62489821

© 2011 The Author(s). Licensee IntechOpen. This chapter is distributed under the terms of the [Creative Commons Attribution-NonCommercial-ShareAlike-3.0 License](#), which permits use, distribution and reproduction for non-commercial purposes, provided the original is properly cited and derivative works building on this content are distributed under the same license.