

Experiments of In-Vehicle Power Line Communications

Fabienne Nouvel¹, Philippe Tanguy¹, S. Pillement² and H.M. Pham²

¹Laboratory IETR Rennes,

²University of Rennes 1, Irisa Labs,

France

1. Introduction

The omnipresence of ECU (electronic control units) in vehicles has led the automotive industry to face a great challenge in its transition from mechanical engineering towards mechatronical products. The X-by-wire and X-tainment applications involve efficient networks that allow bus sharing while reducing both cabling costs, number of wires and connectors.

This chapter deals with the embedded in-vehicle networks and the use of emerging technologies combining different communication systems like power line communications (PLC) and/or wireless communications and pushing to a dynamic configuration of both networks and ECU.

The ECUs that replace mechanical or hydraulic systems require secure and specific bus for communication. In order to exchange information between sensors and actuators, different networks have been proposed, from low data rate up to high data rate namely LIN, CAN, FlexRay. In section 2, these networks are presented identifying their strengths and possible drawbacks. As a result of using these fieldbuses, the cost of advanced systems should plummet. Furthermore, X-by-wire systems do not depend on conventional mechanical or hydraulic mechanisms. In (Len & Hefferman, 2001), the authors demonstrate the advantages of X-by-wire and embedded networks.

Considering these specific domain embedded networks, we can observe that each solution uses its specific wires and communication system. The growth of the complexity leads to the necessity to commit to a limited set of networks which answers to these multiple applications. An attractive solution to reduce the wires is the power line communication (PLC) using the power lines (12/42V) to transmit both the power and the messages without functional barriers domain. It can answer the vehicles requirements namely cost, decrease of the amount of wires, flexibility and bandwidth. Section 3 is dedicated to PLC systems. Nowadays, this technique is already proposed for domestic uses (Ribeiro et al., 2006). In vehicle PLC seems to be a promising technology and has numerous advantages; it could reduce the weight of wires, the amount of splicing, and simplify cables bundle and the networks between ECU. The background and current studies are first addressed in Section 3. Although high data rate and flexibility obtained for indoor domestic PLC are proven, it is not possible to apply them directly to cars because the geometrical characteristics and wires

topologies are totally different. Moreover, the in-vehicle PLC channels are affected by the variable activation schedules of electrical functions, such as brakes, indicators, etc, which produce sharp modifications in the circuit's load impedances over brief time intervals, as presented in (Lienard et al., 2008). To optimize high bit-rate communication, the PLC channel transfer function must be carefully studied because it is frequency selective. Previous studies show that the promising techniques are based on wide bandwidth transmission, such a spread spectrum or orthogonal frequency division multiplex (OFDM). Section 4 provides a description of the experimentations using the existing DC electrical wires. The discussion is framed by describing in particular the area of PLC applications. Results for different cars configurations are presented and demonstrate the feasibility of PLC for automotive.

Section 5 will complete the chapter by describing other alternative solutions for in-vehicle communication based on wireless communications such as ZigBee, Wireless USB, Wifi These technologies have been adopted for V2V, R2V and can be extended to in-vehicle communication. Different solutions are proposed, giving a new perspective for ECU communications, both for cars to cars and/or intra-cars communications.

In order to propose more flexibility with these different communication networks, new electronic architecture need to be adopted to reduce the size of ECU. One solution is based on dynamic reconfiguration. Section 6 will analyze this new concept for our embedded system. Reconfigurable systems are already proposed for video driver assistance (Claus & Stechele, 2010). The reconfiguration can increase both safety and flexibility. An ECU can migrate tasks from one node to another. Furthermore, this functionality can be extended to network architecture: according to the channel, the ECU loads, the modem can be dynamically reconfigured to offer seamless communication between ECUs.

2. In-vehicle networks: overview of embedded solutions

Various vehicle buses for different tasks of communications between ECU are used today according to their area of application (Navet, 2008). These embedded networks have both increased the functionality and decreased the amount of wires. However, the usage of different wires for the different networks still has the disadvantage of heavy, complex and expensive. Among these networks, three of them are prevailing:

- the local interconnect network (LIN, the lowest data rate) : proposed by manufacturers, the local interconnect network is used in on-off devices such as car seats, door locks, rain sensors,
- the control area network (CAN, medium data rate) developed by BOSCH, is currently the most widely used vehicular network. A typical vehicle can contain two or three separate CAN networks operating at different transmission rates, from 125 Kbps up to a higher-speed at 1 Mbps for more real-time-critical functions.
- the FlexRay is proposed for X-by-Wire applications which require higher data rate(10 Mbps) and safety. FlexRay is a fault-tolerant protocol designed for high-data-rate, advanced-control applications. X-by-wire systems replace the mechanical control systems with electronic component.

Figure 1 illustrates the embedded network architecture. We can observe that these networks have a hierarchical structure.

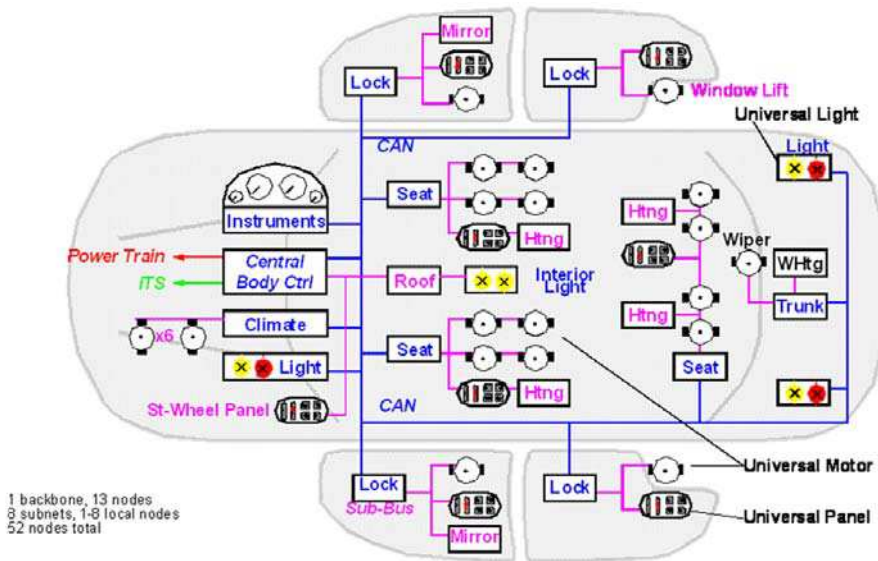

Fig. 1. Network architecture (from [http:// www.freescale.com](http://www.freescale.com))

2.1 The Local Interconnect Network: LIN

Conceived in 1998, the LIN network (LIN, 2003) is an inexpensive slow and serial bus used for distributed body control electronic systems in vehicle. It enables effective communication for sensors and actuators where bandwidth, speed and versatility are not required (i.e. inside mechatronic based subsystems generally made of an ECU and its set of sensors and actuators). LIN is commonly used as a sub bus for CAN and FlexRay. A LIN network is based on one master node and LIN slaves (up to 16 over 40 meters line length). The master node decides when and which frame shall be transmitted according to the schedule table containing the transmission order. At the moment a frame is scheduled for transmission, the master sends the header inviting a slave node to send its data in response. Any node interested can read a data frame transmitted on the bus. The reliability of LIN is high but it does not have to meet the same levels as CAN. The LIN can be implemented using just a single wire, while CAN needs two. The physical layer (PHY) supports a data rate equal to 20 Kbps (due to electromagnetic limitations) but other transmission supports enabling higher data rates are possible. LIN is widely used in middle range cars but it can not support high data rate as required by devices like portable DVD players or multimedia applications.

2.2 The Control Area Network: CAN

The CAN (CAN, 2009) is a widely communication fieldbus used in automotive and other real time applications. It is a serial communications protocol which efficiently supports distributed realtime control with a middle level of security. In automotive ECUs, sensors, anti-skid-systems, etc. are connected using CAN with bit rates up to 1 Mbps. However, in today's car, CAN is used as an SAE (Society of Automotive Engineers) class C (classification defined in J2056/2 Survey, 1994)) network for real time control in the powertrain and

chassis domains (at 250 or 500 kbps). It is also implemented as an SAE class B network for the electronics in the body domain (at 125 kbps).

In CAN, data are transmitted in frames containing up to 8 bytes of data and a number of control bits. A CAN frame is labelled by an identifier whose numerical value determines the frame priority. Depending on the CAN format (standard CAN 2.0A or extended CAN 2.0B) the size of the identifier is 11 bits (CAN 2.0A) or 29-bits (CAN 2.0B). Between CAN frames sent on the bus, there is also a 3 bit inter-frame space. The standard CAN frame format is depicted in Figure 2.

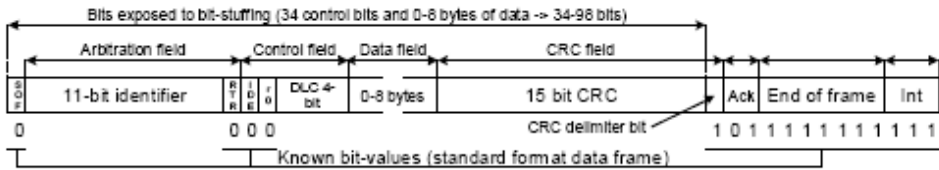

Fig. 2. The CAN frame (from (Nolte, 2006))

Regarding the CAN MAC layer, CAN is a collision-avoidance broadcast bus (CSMA/CA for carrier sense multiple access with collision avoidance), which uses deterministic collision resolution to control access to the bus. It implements a fixed-priority based arbitration mechanism that can provide real time guarantees and that is amenable to timing analysis.

As distributed real time systems become more and more complex, the computing power is steadily growing, and the number of ECUs attached to CAN buses is growing. Thus CAN's maximum speed of 1 Mbps can lead to performance bottlenecks. Hence, methods for increasing the achievable utilisation are needed, e.g., novel analysis methods that allow increased utilisation while guaranteeing timing requirements to be fulfilled, and novel approaches to schedule CAN.

2.3 The FlexRay protocol

X-by-wire systems need fault-tolerant communications with predictable message transmissions and low jitter. This is traditionally solved using TDMA technologies, thanks to their predictable nature. FlexRay (FlexRay Consortium, 2009) is a TDMA communication system developed by a consortium founded in 2000, including both car and semiconductors manufacturers. FlexRay is a fault-tolerant protocol designed for high-data-rate, advanced-control applications. FlexRay is considered by manufacturers as the backbone network for the other networks like CAN or LIN. Currently, FlexRay can handle communications at 10 Mbps. An overview of the FlexRay frame format is given in Figure 3. The frame consists of three segments: the header segment, the payload segment (up to 254 bytes of data), and the trailer or CRC segment.

Communication is done in a communication cycle consisting of a static part and a dynamic part, where each of the parts may be empty. The sending slots are represented through the identifier (ID) numbers that are the same on both channels. The sending slots are used deterministically (pre-defined TDMA strategy) in the static part. In the dynamic part there can be differences in the phase on the two channels. Nodes that are connected to both channels send their frames in the static part simultaneously on both channels. An interesting feature of FlexRay is that it can provide scalable dependability i.e., the "ability to operate in configurations that provide various degrees of fault tolerance."

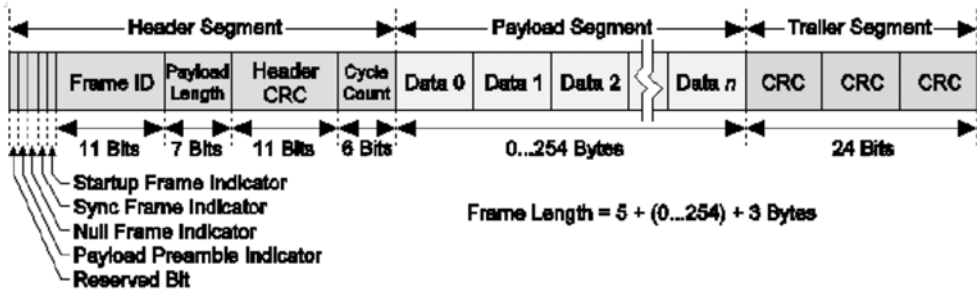

Fig. 3. FlexRay frame (from (FlexRay Consortium, 2009))

However, this network still uses specific wires, which do not achieve compatibility with other networks. So, gateways are necessary to transfer information from ECUs connected to a domain network to ECUs connected to other networks. Those gateways could introduce latency, errors, bottlenecks, and so on.

Other fault-tolerant networks have been developed, namely TTP and TT-CAN, but it seems they are not the best choice for automotive manufacturers due to limited flexibility, high costs and conflicting interests (Nolte, 2006).

Considering these specific embedded networks, we can observe that each solution uses its specific wires and communication system. We can see the wide diversity of the solutions and the necessity to find a limited set of networks which answers to the growing of the multiple applications and requirements. Furthermore, gateways are necessary to switch from one network to another one. This increases the propagation time and does not guarantee real time. One idea to avoid the growth of wires would be to use the PLC technology that is currently developed for indoor AC networks to transmit information over the 12V power distribution (Rubin, 2002). The possible applications of automotive PLC are very wide, extending from low-speed data buses for activating actuators to high-speed multimedia applications.

3. Power Line Communication (PLC)

Many studies are carried out on in-vehicle PLC and focus both on channels, impulsive noises, drivers and protocols. The in-vehicle networks have reduced the number of wires, allowing communication between different typologies of electronic systems (safety devices, entertainment devices, and power train electronics). Additional cost reduction can be accomplished by adopting PLC approach. PLC can be considered to provide the physical layer for serial communications among ECU using for example LIN or CAN transceivers. In this case, the dedicated bus is eliminated. However, PLC can provide both the physical and MAC layers, allowing full compatibility between any ECU. This section considers first the different indoor PLC solutions. Then we focus of in-vehicle PLC driver solutions.

3.1 Indoor PLC

In 2000, a coalition of manufacturers has established a new protocol HomePlug 1.0 that enables the establishment of an Ethernet-IP class network over power line channels (Home Plug V1.0, 2009). The HomePlug process is based on an OFDM technique (Bahai et al., 2004) whose major advantage for the embedded PLC application is to cope with the frequency

selectivity of the power line channel caused by the multiple reflections of the loads connected to the power grid and by the coupling to the other cables placed in the same bundle. The modulation is based on 128 subcarriers equally spaced from 4.3 MHz to 25 MHz, in conjunction coding applied before differential encoding. HomePlug uses CSMA/CA protocol to access to the network. Figure 4 represents the PHY frame format.

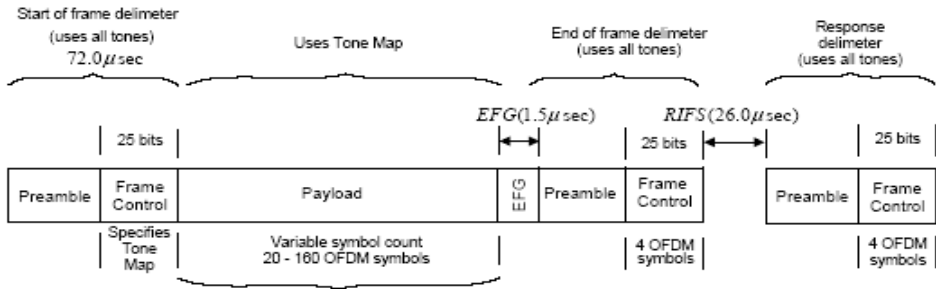

Fig. 4. HomePlug V1.0 PHY frame format (from (HomePlug, 2009))

	Panasonic	HPAV	UPA
Modulation	wavelet OFDM	windowed OFDM	windowed OFDM
Channel coding	RS-CC; LDPC	Parallel-concatenated turbo convolutional code	RS + 4D-TCM concatenation
Mapping	PAM 2-32	QAM 2, 4, 8, 16, 64, 256, 1024	ADPSK 2-1024
FFT/FB size	512 (extendable to 2048)	3072	NC ^{†1}
Max number of carriers	NC	1536	1536
Sample frequency	62.5 MHz	75 MHz	NC
Frequency band	4-28 MHz 2-28 MHz optional	2-28 MHz	0-30 MHz 0-20 MHz optional
PHY Rate	190 Mbps	200 Mbps	200 Mbps ^{‡5}
Information Rate	NC	150 Mbps	158 Mbps ^{‡5}
Programmable notches	Yes	Yes	Yes
Power Spectral Density	NC	-56 dBm/Hz ^{†6}	-56 dBm/Hz ^{†4}
Media Access Method	TDMA-CSMA/CA	TDMA-CSMA/CA	ADTDM ^{†2}
Hidden Node Avoidance	NC	Yes	Yes
Duration MAC frame	NC	Variable	Variable
MAX number of nodes	64 ^{†3}	NC	64 ^{†4}
Network identifier	Yes	Yes	Yes

Table 1. PHY and MAC layers of current PLC solutions (from (OMEGA, 2008))

More recently, the HomePlug AV (HPAV) has been introduced and will be the second major standard released by the HomePlug Powerline Alliance (Gavette, 2006) (Afkhamie et al.,

2005). The main HomePlug AV's objective is to distribute multi-media content within the house as well as data. The PHY layer still operates in the frequency range of [2 - 28] MHz and provides a 200 Mbps PHY channel rate (150 Mbps net information rate).

Long OFDM symbols with 917 usable carriers (tones) are used in conjunction with a flexible guard interval. Modulation densities from BPSK to 1024 QPSK are independently applied to each carrier based on the channel characteristics between the transmitter and the receiver. Experimental systems of HPAV have been field tested in houses, suggesting that on average HomePlug AV system achieves 10 times the data rate of a HomePlug 1.0 system.

At the same time, The HD-PLC (High Definition Power Line Communication) (Galli, 2008) solution has been proposed by Panasonic. It is based on a specific OFDM modulation called Wavelet-OFDM which exploits the Wavelet transform combined with 2 to 16 PAM modulations. The Wavelet OFDM achieves highly efficient transmission with characteristics that exceed even FFT-based OFDM systems. Wavelet OFDM features greater speed efficiency and forms a deeper "flexible notch" that prevents interference with shortwave and other broadcasts. No guard interval is included. The MAC layer uses the hybrid TDMA and CSMA/CA protocols synchronized with the AC line cycle. Table 1 summarizes the current PLC solutions.

Today, the HomePlug Alliance, HD-PLC alliance and the IEEE (IEEE P1901, 2008) are strongly committed to delivering a single mature solution that will be endorsed by the IEEE P1901 work group as the baseline standard. A standard for high speed (over 100 Mbps at the physical layer) communication will be proposed and will use transmission frequencies up to 100 MHz. These PLC solutions could be investigated in an automotive environment.

3.2 In-vehicle PLC

Although high data rate and flexibility obtained for indoor domestic PLC are proven, it is not possible to apply them directly to cars because the geometrical characteristics and wires topologies are totally different. PLC can be considered for the PHY layer only or for the MAC and PHY layers. These two configurations are considered below.

In (Benzi et al., 2008), the authors focus on the issues that need to be addressed when introducing PLC in vehicle. Three main domains need to be covered: the physical (PHY) layer, the data link layer and the performances. In order to answer to them, the properties of the automotive in board PLC supply networks have been investigated (Huck, 2005) (Arabia et al., 2006), (Degardin et al., 2006), (Mohammadi et al., 2009). The results show the insertion losses over the [0-30] MHz bandwidth are about -15 dB and -36 dB in the frequency range [0.500-30] MHz. The noise measurements show an increasing background noise in the frequency ranges [0-100] MHz, especially at frequencies less than 10 MHz, the peaks of the noise could be in the range [-90 dBm/Hz; -40 dBm/Hz]. Varying space between cabling and car body results in changing behaviour of the whole system. A new wiring harness structure is proposed in (Benzi et al., 2008), based on a star structure using active star couplers. The transfer function of this wiring seems to be more flat in the range between 150 and 250 MHz. However this solution needs to re-organize all the harness, which is different from one vehicle to another one.

Considering first the PLC for the PHY layer, a power line communication system over 12 to 42 V wires combining the LIN protocol and a PLC driver has been proposed (De Caro, 2009). In order to avoid interferences between the master and slaves LIN nodes, two different transmission modes have been adopted, one based on BPSK for master to slave

transfers, while slave mode exploits a BASK modulation. The modulation must support data transfer at 10 Kbps, while the accepted conducted emission limits need to be less than 53 dB μ v in the [1-30] MHz band. Two carriers have been selected, one at 100 KHz for low power modules and one at 2 MHz for high power modules. Although this LIN and PLC transceiver is an attractive solution, the data rate remains under 10 Kbps that is not convenient for X-by-wire applications.

A similar approach has been proposed for CAN protocol by many authors (Yamar, 2009), (Silva et al., 2009) (Beikirch et al., 2000). The Yamar solution implements CAN and PLC using the DC-BUS technology with different bit rates up to 1.7 Mbps. It uses narrow band channels with a center frequency between [2-12] MHz. The DC-BUS protocol uses the CSMA/CA multiplex mechanism allowing bidirectional communication up to 16 nodes. In addition, this CAN-PLC solution can be used as a redundant channel for the CAN protocol. However, this solution still does not answer to data rate over 10 Mbps.

Additional PLC drivers combining MAC layers have been presented in (Benzi, 2008). The commercial solutions are available for automotive but to our knowledge not implemented yet in vehicles.

More recently, PLC in electric vehicles has been studied in (Bassi et al., 2009). One can think that the requirements of such communication system within an electrical car differ from a fuel car. An experimental setup has been built. It uses 2 ECUs and 2 DCB500 transceivers to modulate the DC-line. The DCB500 transceivers feature PLC communication over DC-line with a bit rate up to 500 Kbps. The conducted and irradiated emissions show substantial compatibility, except for the lower end frequencies (under 1 MHz) where significant peaks are highlighted. In addition, different channel measurements in electric cars have been carried out in (Barmada et al., 2010). Different cases are considered (front to/from rear part) with different vehicle's configuration (position key, battery,...). As for fuel vehicle, the channels are very frequency selective in the [0-30] MHz. We can conclude that the fuel and electric vehicles seem to have similar behaviours in term of frequency channel and noise for PLC applications.

Another solution for PLC is to consider both the MAC and PHY layers. Considering the channel measurements, the candidate techniques for in-vehicle PLC are spread spectrum combined with code division multiple access (CDMA) (Nouvel et al., 1994) and OFDM. OFDM allows high data rate and outperform CDMA performances in term of throughput and frequency selectivity.

Experimentations using indoor OFDM PLC modems have been carried out and presented in detail in previous studies presented in (Gouret et al., 2006), (Gouret et al., 2007), (Nouvel et al., 2008), (Degardin, 2007) and more recently in (Nouvel et al., 2009A). The results are very promising. Data rate up to 10 Mbps/s can be achieved in the [0-30MHz] bandwidth. The solutions are based on HPAV standards. In (Nouvel et al., 2008) two PLC modems have been tested: SPIDCOM (Spidcom, 2008) and DEVOLO modems. In the SPIDCOM modems, the OFDM modulation is based on 896-carriers from 0 to 30 MHz divided into 7 equal sub-bands. The MAC layer provides a mechanism based on TDMA and CSMA/CA is also available. The PHY and MAC layers are similar to the HPAV ones but differ in some points: number of sub-bands, equalization, and synchronization. With these SPIDCOM modems, an 8 Mbps is achieved with a transmitted power of -50 dBm. With a higher level (-37 dBm), we achieve about 12 Mbps. For multi-media applications, this rate can be sufficient, but decreases rapidly according to the loads. Then measurements have been carried out with

DEVELO PLC modems. They comply with HPAV and support data speed of up to 200 Mbps in a range of 200 meters within a household grid. For intra-car communications, the power supply and the coupling have been modified to take into account the DC channel. Additional measurements are presented in next section. Figure 5 illustrates the spectrum of the transmitted signal over the DC line.

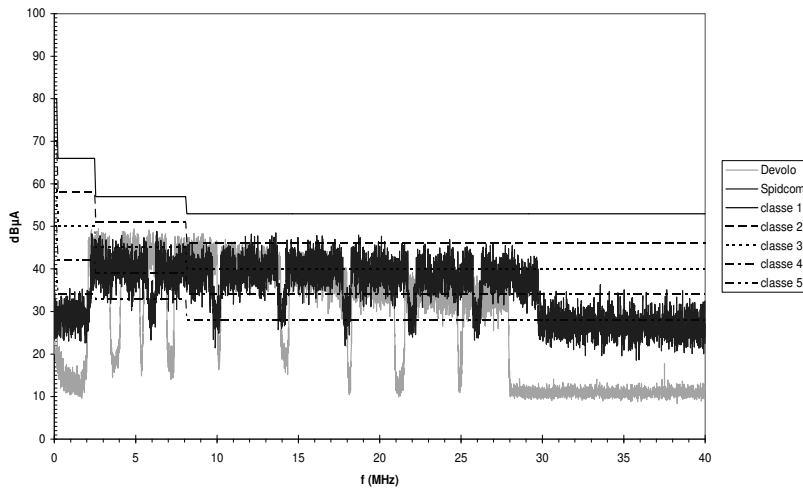

Fig. 5. HPAV and Spidcom spectrum over DC line

Beyond these promising results, the choice of the modulation parameters will be driven by the PLC channels and optimized with regards to the bandwidth, the modulation technique, the coding rate, the guard interval, and so on. This discussion is presented in the next section.

4. In-vehicle measurements

In this section we deal with in-vehicle PLC measurements. In a first time we show some results about real PLC transmissions. Indeed, we have decided to test the feasibility to adapt indoor PLC modems in car. Then, we study in more details the in-vehicle PLC channel with different measurements about the transfer function and the noise. To achieve the capacity of the channel through the cables for PLC, many transfer functions between nodes in the vehicle have been measured. Noises have also been considered.

4.1 In-vehicle PLC transmissions

4.1.1 Data rates measurements testbed

We have tested two indoor PLC modems complying with the standards HPAV and HD-PLC in one car. We have measured throughputs at different points on a gasoline Peugeot 407 SW.

The Figure 6 illustrates the different points used during the throughput measurement. Several scenarios have been used:

1. Car with engine-turned off

2. Car with engine-turned but not moving
3. Car with engine-turned but not moving and effects of lightning, warnings, radio, windscreen wiper, electric windows
4. The car in motion and the effects of the equipments like in 3)

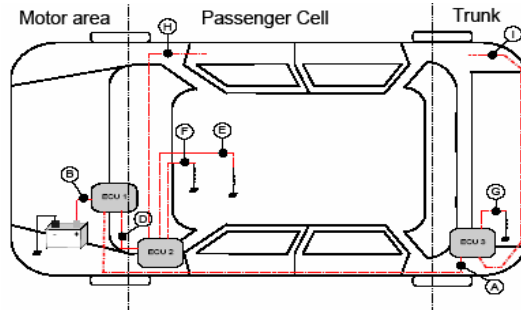

Fig. 6. Measurement scheme: the different uppercases represent the measurement points

The measurements have been achieved with two PLC modems and two computers which have been plugged into the different points shown Figure 6. Therefore, we have measured the TCP throughput between two points with two modems and two PC. The measurement between points A and D has been called path AD. The throughputs are measured associated with the payload ignoring headers. The throughput is also called “Goodput” according the definition in section 3.7 of (Newman, 2009).

4.1.2 Results and discussion

Throughputs for different points have been studied and we can first observe a difference between scenario 1) and the others. Figure 7 to 9 represent the throughput we obtain with the two modems. Throughputs in Figure 7 are higher than 35 Mbps, and in Figures 8 and 9 more than 15 Mbps are achieved for all paths.

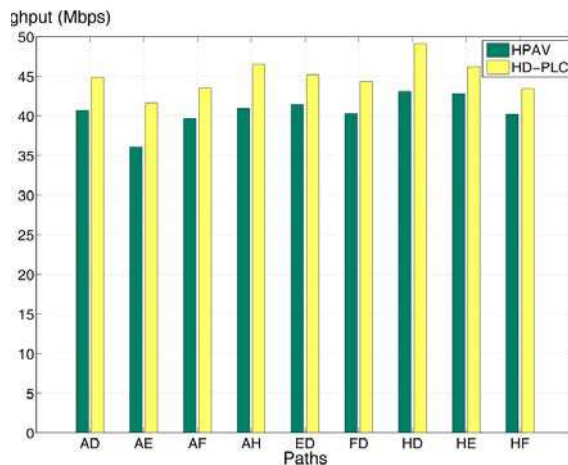

Fig. 7. HPAV and HD-PLC throughputs comparison

For scenario 2), 3) and 4) we remark that the HPAV has the best performances. Moreover, we can observe short variations between the scenarios for the two indoor standards. Furthermore there is a throughput difference according to the path in-vehicle. Indeed, we can see that the path HD has throughput higher than all the others.

Indoor PLC standards have been designed according indoor channel characterization. Moreover, the power level of the transmitted signal has been chosen according to the indoor CEM constraints. In fact, to respect the vehicle CEM it has been said in (Degardin et al., 2007) that the power level of transmitted signal should be between -60 dBm/Hz and -80 dBm/Hz. This specific point must be taken into account for next PLC in-vehicle transmission. That's why measurements on several vehicles have been achieved and are discussed in the next subsection.

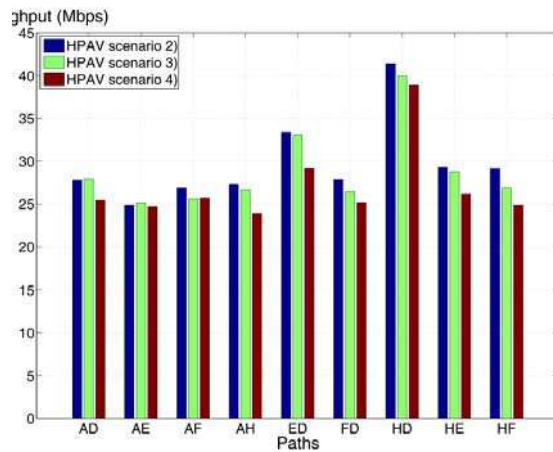

Fig. 8. HPAV throughputs for different paths in-vehicle for scenario 2), 3) and 4)

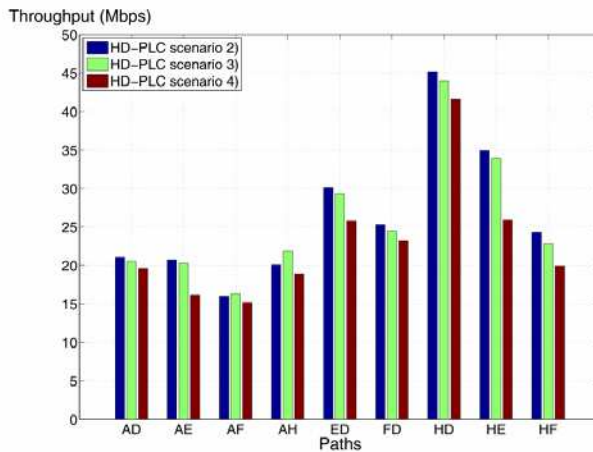

Fig. 9. HD-PLC throughputs for different paths in-vehicle for scenario 2), 3) and 4)

4.2 In-vehicle channel measurements

In order to design a future PLC modem it is necessary to study the PLC in-vehicle channel. Here the transfer function and the background noise is studied.

Additional measurements have been performed on recent vehicles for two classes of paths: front to front and rear to front (Tanguy et al, 2009). Figure 10 and 11 illustrate the results according to our testbed (Figure 6). In order to analyze the DC PLC architectures, additional transfer functions are measured on four different vehicles. The vehicles are classified according to: the number and type of ECUs, the length of wires, the combustion engine.

4.2.1 Measurement testbed

The S-parameters are recorded using a full 4 ports Vector Network Analyzer (VNA) and a PC interfaced to remote the device. We record the S-parameters during about 10 minutes while the car is moving. The S-parameters are recorded about every 10 seconds for the 3 different paths: GF, GH and HD. Compared with the previous subsection we have introduced a new measurement point called G which is for the most of vehicle tested a cigar lighter receptacle. These paths have been chosen in order to analyze the differences between front to front and rear to front.

Regarding the noise, the same points have been considered: G, D, F and H. Two different noise studies have been carried out. The first consists of the measurement of the power spectrum at each point during 10 minutes every 10 seconds with the vehicle moving. The second is a measurement in the time domain. In fact, a digital storage oscilloscope (DSO) has been used to record at each point the signal over the DC line. With this testbed we are able to record two signals at two different points in the same time. Thus, we can observe the level of noise at two different points simultaneously. Finally, the measurements have been performed on a Peugeot 407 SW gasoline and diesel, a Renault Laguna II Estate and a Citroën C3.

4.2.2 Results & discussion

Figure 10 and Figure 11 show an example of time and frequency responses for the three paths GF, GH and HD and for a measurement bandwidth of [1-31] MHz. The impulse responses have been calculated with the inverse Fourier transform of complex parameter S21.

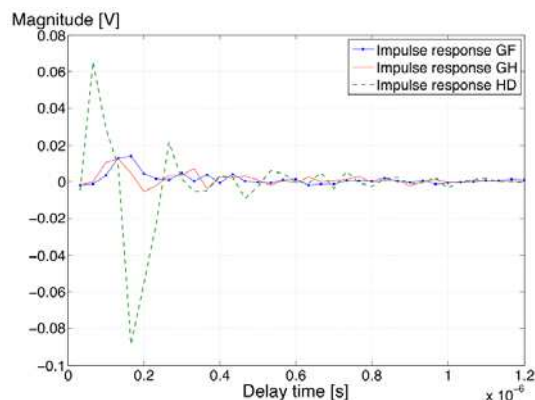

Fig. 10. Impulse response for 3 paths GF,GH,HD on 407SW gasoline

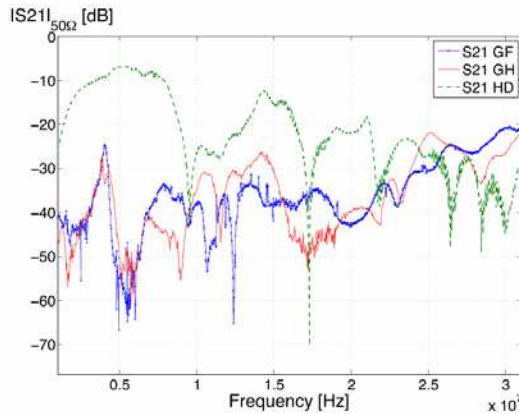

Fig. 11. S21 for 3 paths GF, GH and HD on 407 SW gasoline

		Min	Max	Mean	Std
BC0.9 GF	407 gasoline	391.8 KHz	832.6 KHz	533.8 KHz	89.9 KHz
	407 diesel	538.7 KHz	881.6 KHz	666 KHz	81.6 KHz
	Laguna II	4.3098 MHz	4.8976 MHz	4.7163 MHz	142.8 KHz
	C3	440.8 KHz	1.3713 MHz	1.1587 MHz	143.9 KHz
BC0.9 GH	407 gasoline	1.3713 MHz	2.1059 MHz	1.7578 MHz	190.3 KHz
	407 diesel	97.9 KHz	1.0775 MHz	748.3 KHz	227.3 KHz
	Laguna II	1.0775 MHz	1.2734 MHz	1.1443 MHz	45.6 KHz
	C3	489.8 KHz	1.5182 MHz	1.0591 MHz	331 KHz
BC0.9 HD	407 gasoline	1.8121 MHz	2.057 MHz	2.006 MHz	40.8 KHz
	407 diesel	685.7 KHz	734.6 KHz	712.6 KHz	24.5 KHz
	Laguna II	685.7 KHz	832.6 KHz	744 KHz	31.9 KHz
	C3	881.6 KHz	1.0775 MHz	995.8 KHz	46.4 KHz

Table 2. Coherence bandwidth (BC0.9) for 3 paths (GF, GH and HD) and for 4 different vehicles

In a previous study on in-vehicle PLC (Lienard et al., 2008) a delay spread under 380 μ s and a coherence bandwidth greater than 400 KHz has been found. Moreover, in Table 2, we observe the coherence bandwidths are different from one vehicle to another and from one path to another. This means that the modulation must be adaptive.

Regarding the average attenuation we can also observed differences between the different paths. For example, the Renault Laguna II Estate has a mean average attenuation of 9 dB for the path GF, 31.6 dB for GH and 31.5 for HD. But the 407 SW gasoline has a mean average

attenuation of 40.1 dB for the path GF, 40.4 dB for GH and 24.4 for HD. Otherwise, we have a maximum average attenuation of 69.3 dB for the path GH of the 407 SW diesel and a minimum average attenuation of 5.8 dB for the path GF of the Laguna II.

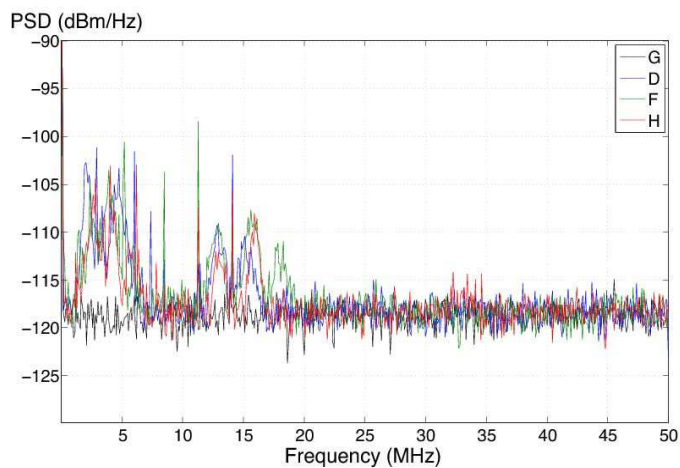

Fig. 12. Noise measured with a spectrum analyser for 4 different paths on a Peugeot 407 SW gasoline

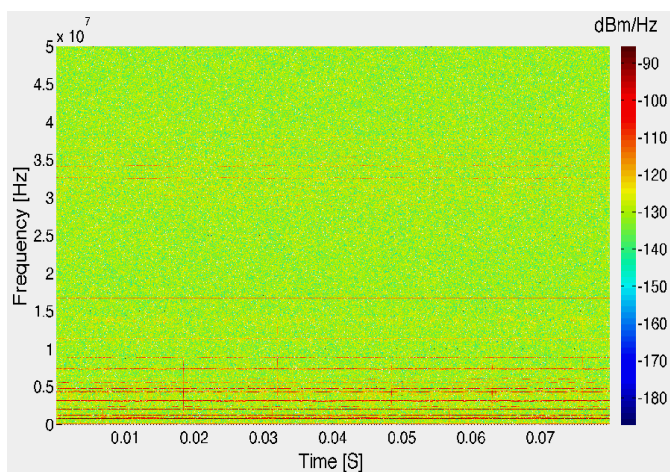

Fig. 13. Spectrogram computed with the DSO recording at point G measured on a Peugeot 407 SW gasoline

To optimize the modulation parameters, we have to consider the noise. Figure 12 represents an example of noise measurement with a spectrum analyzer for 4 different points in a Peugeot 407 SW gasoline. We observe an increase of noise for some frequencies in the bandwidth [0 - 5] MHz. Moreover we can see narrowband noises. Like in (Yabuuchi et al.,

2010) we have applied to noise recordings in-vehicle a time frequency analysis. In Figure 13 we show an example of spectrogram computed with the DSO recording at point G measured on the same vehicle. We have computed the spectrogram with short-time Fourier transform where an Hamming window of length equal to the length of HPAV OFDM symbol (40.96 μ s) and an FFT size of 3072 points like in HPAV standard.

In Figure 13 we can observe that in the bandwidth [0 - 5] MHz the noise is constant during the time of the recording. Therefore, in the case of a multi-carriers modulation transmission in the bandwidth [2-30] MHz some subcarriers will be affected during all the transmission time.

We have observed that the average attenuation, the coherence bandwidth and the RMS delay spread are very different according the vehicles, the paths in-vehicle and the paths between vehicles. We verified the capacity for each paths of each vehicles with the parameters of the Table 3 according to

$$C = \Delta_f \sum_0^{N-1} \log_2(1 + SNR_i) \quad (1)$$

with Δ_f the subcarrier bandwidth, $SNR_{\{i\}} = (H_{\{i\}})^2 \cdot P_e / P_n$ the signal to noise ratio per subcarrier, P_e is the PSD of the emitted signal and P_n is the PSD of the AWGN noise.

Parameters	Values
Fmin	1 MHz
Fmax	31 MHz
Subcarrier	N=1228
FFT/IFFT	3072
Δ_f	24.414 KHz
PSD of noise (P_n)	- 120 dBm/Hz
PSD of signal (P_e)	-60 dBm/Hz

Table 3. Simulation parameters: FFT/IFFT and Δ_f values are parameters used by the HPAV standard

The results show the minimum of the average capacity is about 190 Mbps for the path GH of the Peugeot 407 SW diesel and the maximum is about 507 Mbps for the path GF of the Laguna II. We observed also differences between the paths and the vehicles.

The vehicles have not the same electrical topology. In fact, it depends on car manufacturer, the size of vehicles, the number of ECUs ... Therefore the load on the electrical network, the length of wires and the junctions between cables are different. We have several channels which are different according the paths and the vehicles like we have shown with the coherence bandwidth, the time delay spread, the channel gain and the capacities.

The multicarrier modulation seems to achieve good performances like we have seen during the throughput measurement of HPAV and HD-PLC standards. In this study, only the

channel function transfer and the background noise have been studied. The impulsive noise is an other important aspect to take into account (Umehara et al., 2010) and (Degardin et al., 2008) for powerline communication. According to us the MAC/PHY layers must be designed to take into account the differences between vehicles and the differences between paths in-vehicle. Future work will be focus on the integration in a simulator of all the channel measurements (transfer function, background noise, narrowband interference and impulsive noise) in order to optimize the modulation scheme.

5. In-vehicle wireless communications

The interest in wireless networking has grown significantly due to the availability of many wireless products. Looking at in-vehicle communications, more and more portable devices, e.g., mobile phones, laptop computers and DVD player can exploit the possibility of interconnection with the vehicle. Wireless communication could be an attractive solution to reduce the number of cables and disturbances in cars. We have reviewed potential wireless solutions, specifically two of them in (Nouvel et al., 2009A). We have performed tests similar to PLC tests in order to qualify the channel in the 2.4 GHz band. Data rate measurements show it is possible to achieve more than 10 Mbps/s in the vehicle, using also OFDM technology. Additional studies have been carried out in (Nolte et al., 2009). The authors in (Zhang et al., 2009) have conducted measurements in the [0.5 - 16] GHz band. One can observe the different delay profile, different clusters, different paths and the impact of passengers. Due to lake of space, it is not possible to describe all the measurements. And we invite the interested readers to look at the papers and chapters.

6. From static to dynamic ECU and communication networks

Taking into account all these networks, from specific network up to PLC or wireless combined with the constraint of flexibility and security, one attractive idea is to be able to switch from one network to another one, without additional cost. If the main communication fails, the ECU (modem) can switch to the secondary protocol and continue to run. Reconfigurable architectures based on FPGA may offer very flexible links inside a vehicle. A dynamically reconfigurable system allows changing parts of its logic resources without disturbing the functioning of the remaining circuit. This property can be applied for networks, in order to allow changing from one protocol to another one according to the channel behaviour, errors, load, etc. This section will discuss about this new concept and demonstrates how it can be integrated in vehicle.

Certain modern FPGAs offer dynamic and partial reconfiguration (DPR - Dynamically and Partially Reconfigurable) capability that allows to change dynamically one portion of the FPGA without affecting the rest of the circuit. Currently, the Xilinx Virtex FPGAs (Xilinx, Inc, 2008) are the only commercially available circuits supporting the DPR paradigm and large applications implementation. Internal structure of a Xilinx Virtex5 is presented in Figure 1. The main resources dispatched in the FPGA matrices are slices, DSP blocks (DSP48E), memory blocks (BRAM), input/output (IO) banks, and Clock Management Tiles (CMTs) as well as the reconfiguration interfaces, so called ICAP. Slices are the smallest configurable elements constituted of LUTs (Look-Up Table), registers and logic gates. DSP blocks offer a powerful set of processing elements for data applications.

The dynamic reconfiguration takes place in Partially Reconfigurable Region (PRR) which can be partially reconfigured independently. Designing a dynamically self-reconfigurable system always require the declaration of PRRs. A PRR is implemented statically despite the fact that its content is dynamic. Thus, at runtime, dynamic reconfiguration can only take place into the PRR. Communications between a dynamic task and its static environment is assured through the bus macro interfaces. Bus macros are also specified statically.

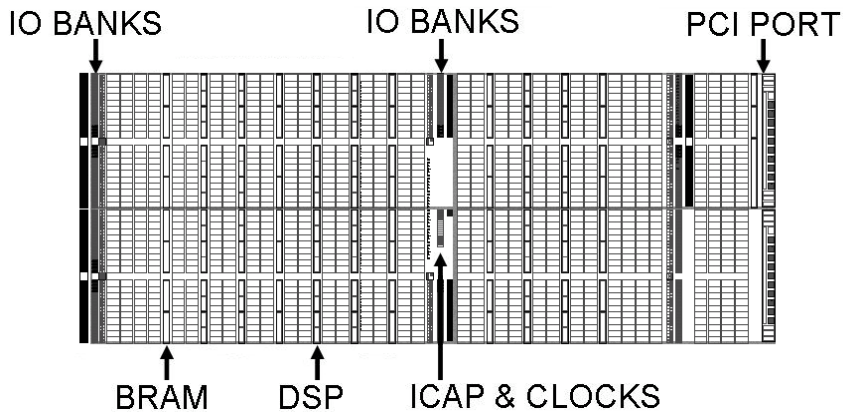

Fig. 14. View of the Virtex5 5VSX50T captured from Xilinx PlanAhead design tool

The FPGA fabric is partitioned into one static logic and one or more partially reconfigurable regions (PRRs). This fabric partitioning enables reconfiguration of a single PRR without system interruption (the static region and other PRRs continue execution while only the reconfigured PRR halts). Each PRR has a related partial bitstream and the reconfiguration process can be done by sending this partial bitstream to the reconfiguration port. In modern FPGAs, the reconfiguration is stored in SRAM based memory, leading to a weakness from a reliability point of view.

Modern FPGAs, besides customary high-density reconfigurable resources, offer the designers the possibilities of implementing programmable processors having features of Commercial Off-The-Shelf (COTS) components (no need to modify processor architecture or application software). Processors play the role of processing units, and one particular is used as coordination units in the embedded system. Besides, processors are in charge of collecting the data from peripherals and from the memory, process the data and send them to the memory and to the peripherals. Also, processors manage the memory and initialize the peripherals. Xilinx FPGA devices include two categories of processors: the hardcore embedded processor (PowerPC) (Xilinx, Inc, 2004) and softcore processors (MicroBlaze, PicoBlaze) (Xilinx, Inc, 2009). Hardcore embedded processors are hard-wired on the FPGA die and their number is limited on each device. On the other hand, softcore processors use reconfigurable resources, so the number that can be actually implemented depends on the device size only. The MicroBlaze tasks can be classified into 2 types: hardware tasks and software tasks. Hardware tasks are peripherals connecting to MicroBlaze. Software tasks are software programs running inside MicroBlazes. Generally, hardware tasks are designed using High Description Language HDL like VHDL, Verilog and software tasks are programmed using C. Regardless of their design methods they are presented in our system

in compiled forms of binary files called bitstreams. A bitstream is the set of binary data describing the circuits implemented on the FPGA, or in PRRs (partial bitstream). Shorten term "bitstream 1" will refer to all the bitstreams of FPGA1, idem with "bitstream 2" for FPGA2,

The processor software context is a set of information needed to uniquely define the state of the processor at a given moment. It could include the states of the processor registers, the cache, the memory, etc. Saving and restoring all relevant values allow for processor context switching and error recovery. The softcore processor MicroBlaze context is represented by the 32-bit values of 32 General Purpose Registers and two Special Registers: the Program Counter (PC) and the Machine Status Register (MSR).

A MicroBlaze task migration consists in migrating hardware task, software task and restoring the software context. Hardware task migration requires the appropriate peripheral to be added using dynamic reconfiguration. Software context is also migrated by dynamic reconfiguration. And copying the saved software context into the related MicroBlaze program memory does the software context recovery process.

Due to their flexibility, FPGAs are attractive for mission-critical embedded applications like automobile domain, but their reliability could be insufficient unless some fault-tolerance techniques capable of mitigating soft errors are used. Dynamic partial reconfiguration provide not only the flexibility in both hardware and software, but also further solutions dealing with reliability problem in critical domains. The dynamic reconfiguration allows the reloading of the defected module to the correct state and the re-execution of the attributed tasks. It cans also re-distribute defected tasks in the faulty module to other processing units in the system.

We present here the feasibility of integrating dynamic reconfiguration features into automotive-aimed applications in which certain fault-tolerance degrees should be maintained. In case of a fault occurrence, the system must be capable of react in real-time to ensure the safety for driver as well as pedestrian. The reaction in this case can be the fast fault detection and correction by loading the original configuration to put the faulty module to the state as at start-up. It can also be the critical task migration from the defected module to another module.

To define a new embedded automotive platform based on reconfigurable architecture, in CIFAER (CIFAER, 2008) we advocate for the use of Radio Frequency and Power-Line Communication for intra-vehicle communications (Nouvel et al., 2008). The communication can be switched from one to the other by dynamically reconfiguring a defined communication zone on an FPGA. These two modes offer very flexible links inside a vehicle. Figure 15 shows the fault-tolerant multi-FPGA platform. The system consists of four FPGAs connected together using two Ethernet communication (in future development one will be based on PLC interface, while the other will be constructed on RF connections). The first network is routed via a network switch, the other network form a ring topology for the fault-tolerance purpose. The Ethernet protocol is built by Ethernet controller as MicroBlaze hardware peripherals and LightWeight IP (LightWeight) as the software library. The lwIP is an open-source stack using TCP/IP protocol, which can be easily adapted to PLC and wireless modem. Each FPGA contain a fault-tolerant dynamic multi-processors system, consisting of several MicroBlaze (Figure 16). Further details about this system architecture, called FT-DyMPSoC, as well as the fault-tolerance schemes implemented can be found in (Pham et al., 2009) and (Pham et al., 2010) for interested readers.

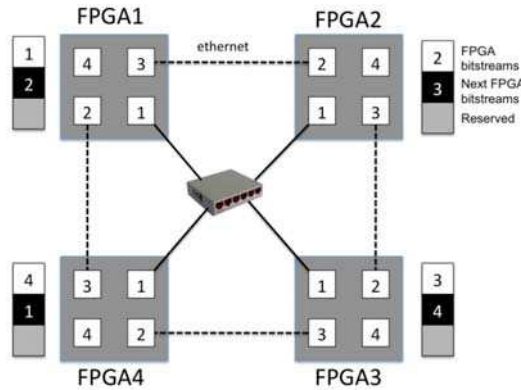

Fig. 15. Fault-tolerant multi-FPGA platform. Two communications networks are supported for reliability purpose

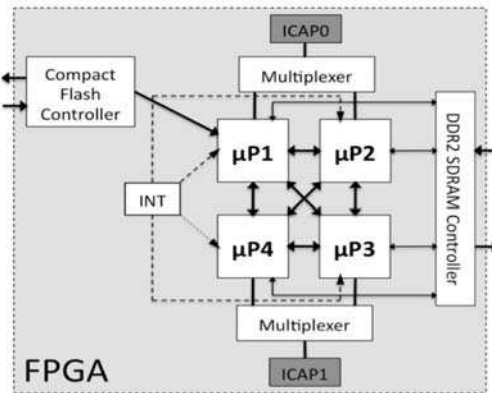

Fig. 16. FT-DyMPSoC Architecture. Included in each FPGA this architecture insert fault-tolerant mitigation schemes

On the overall system, each FPGA is interfaced with a memory that can be accessed by all the processors inside the same FPGA. This memory is partitioned into three segments (Figure 15):

- One for saving all the bitstreams and the software contexts of all the processors of this particular FPGA.
- One for saving all the bitstreams of the next FPGA in the ring network.
- One reserved and used in case of failure occurrence in the system. This segment helps to transfer the bitstreams and contexts between different FPGAs.

The memory segmentation guarantees the existence of at least one copy of all the bitstreams over the whole network.

As we can see in Figure 17, the bitstream of each FPGA is present in its local memory and also in the local memory of the previous FPGA in the ring topology. For example, FPGA1 stores its own bitstream 1 and and the bitstream 2, FPGA2 stores bitstream 2 and bitstream 3... These copies will be used in case of system failure, and permit fast context switching.

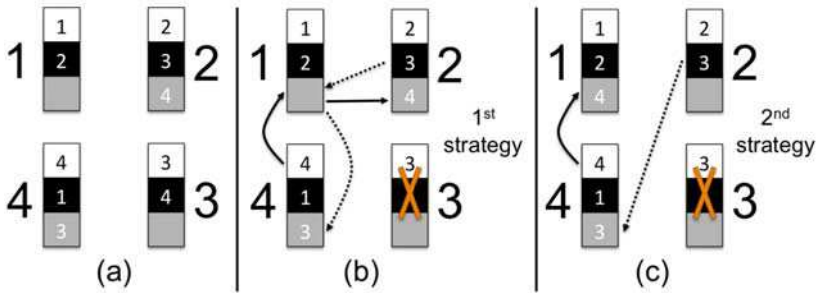

Fig. 17. Fault recovery strategies. Once the faulty FPGA is identified, the copies of the bitstreams are exchanged in order to keep a valid copy of all the configurations

The fault-tolerance degrees are maintained at two levels in the system. The Intra-FPGA level corresponds to the fault-tolerance strategy inside each FPGA, and is related to the design of the FT-DyMPSoC system. The fault-mitigation strategy is realized using the connection matrices algorithm (Pham, 2009), and fault are mitigated by using dynamic reconfiguration at the processors level. The second level called Inter-FPGA level corresponds to the overall system presented in Figure 15. To detect error in the overall network, all the FPGAs exchange frequently among them detection frames. These frames contain the software contexts of the four MicroBlazes of each FPGAs. On one hand, this helps detecting error in the network. On the other hand, including the contexts within the detection frame will help to resume the tasks of a faulty FPGA on another FPGA. During the exchange if the contexts of one FPGA (i.e. FPGA3 in Figure 17) are not received by the others circuits, the FPGA3 is declared faulty. There are 2 possibilities: the MicroBlaze 1 (supporting the interface to the network) of FPGA3 is faulty, causing the communication lost of this FPGA, or the whole FPGA3 is faulty. In order to distinguish these 2 possibilities, the secondary ethernet links is used. FPGA2 and FPGA4 try to communicate with MicroBlaze 2 and 3 of FPGA3. If these communications fails, the whole FPGA3 is declared defected, if not, only the MicroBlaze 1 is defected.

If only one MicroBlaze inside one FPGA fails, we can manage this error thanks to dynamic reconfiguration of this processor or by using task migration within the MPSoC system. The error is managed at the FPGA level. If the whole FPGA fails the task migration concerns the overall circuit. In this case the task of the FPGA3 needs to be dispatched across the remaining circuits. If the system cannot manage all the tasks with one missing FPGA priority needs to be defined and used to maintain critical services for example. In this case, arbitration on the running tasks needs to be executed, and reconfiguration of the remaining FPGA is launched.

If one FPGA is lost, we need to maintain the two bitstreams copy stored in the faulty FPGA. For example, if the FPGA3 is lost (Figure 17), the copies of bitstream 3 and 4 are inaccessible requiring a clone of bitstream 3 and bitstream 4. We propose here 2 strategies delivering the bitstream 3 and 4 to other FPGAs.

1. The first strategy uses only the secondary communication media. We need to use FPGA1 reserved segment as intermediate medium. First the bitstream 4 is copied from FPGA 4 to FPGA1 reserved segment, then to FPGA2. Afterwards, bitstream 3 is copied from FPGA2 to FPGA1, then to FPGA4.

2. The second strategy requires both communication media. Bitstream 4 is copied from FPGA4 to FPGA1 using direct Ethernet link. Simultaneously, bitstream 3 is copied from FPGA2 to FPGA4 using the primary Ethernet via the switch.

In case the Ethernet switch fails, all the primary Ethernet connections are defected; This leads to a connection loss between all the FPGAS. At this moment all circuits switch to the ring topology. The second network will then ensure proper operation of the overall system. The use of redundancy of the network, coupled with the new dynamically reconfigurable paradigm permits to construct highly reliable system.

7. Conclusion

In this chapter, an initial foreseeable solution with PLC has been presented to allow communications and interoperability between embedded applications with different requirements. PLC network answers both to cost, flexibility and throughput requirements. Future work should be devoted to optimize both PLC modulations and ECU architectures in order to minimize the number of cables and ECU etc. This implies rethinking the DC bundles as rethinking the implementation of networks as independent domain.

Furthermore, it is possible to build a reconfigurable ECU for both application and communication. This new concept will allow combining different network technologies. It will answer to fault tolerance constraints, required in X-by-wire applications

This work has been carried out by the CIFAER project, supported by the ANR and by the French Premium Cars competitiveness Cluster ID4car.

8. References

- Afkhamie, K.H.; Katar, S.; Yonge, L. & Newman R. (2005). An overview of the upcoming HomePlug AV standard, *Proceedings of the IEEE International Symposium on Power Line Communications and Its Applications*, pp. 400-404, 0-7803-8844-5, 6-8 Apr. 2005, Vancouver, BC, Canada.
- Arabia, E.; Ciofi, C.; Consoli, A.; Merlino, R. & Testa A. (2006). Electromechanical Actuators for Automotive Applications Exploiting Power Line Communication, *Proceedings of SPEEDAM*, pp. 909-914, 1-4244-0193-3, Taormina, 26-26 May 2006
- Bahai, A.; Saltzberg, R. & Ergen, M (2004). *MultiCarrier Digital Communications*, ISBN: (HB) 0-387-22575-7, Springer NewYork
- Barmada, S.; Raugi, M.; Tocchi, M. & Zheng, T. (2010). Powerline communication in a full electric vehicle, *Proceedings of IEEE International Symposium on Power Line Communications and Its Applications*, pp. 331-336, 978-1-4244-5009-1, Rio de Janeiro , 28-31 March 2010
- Bassi, E.; Benzi, F.; Almeida, L. & Nolte, T. (2009). Powerline communication in electric vehicles, *Electric Machines and Drives Conference*, pp. 1749-1753, 978-1-4244-4251-5, Miami, 3-6 May 2009
- Beikirch, H. & Voss, M. (2000). CAN-transceiver for field-bus power line communication, *Proceedings of the International Symposium on Power Line Communications and Its Applications*, Limerick, pp. 257-264, April 2000
- Benzi, T.; Facchinetti, T. Nolte & Almeida L. (2008). Towards the powerline alternative in automotive applications, *Proceedings of Factory Communication Systems*, pp. 259-262, 978-1-4244-2349-1, Dresden, 21-23 May 2008

- CAN. (2009), Retrieved from official web site <http://www.can-cia.org/> (2009)
- CIFAER (2008), Communications Intra-véhicule et Architecture Embarquée Reconfigurable, French ANR Project 2008-2011. Available at web site www.agence-nationale-recherche.fr/AAPProjetsOuverts
- Claus, C.; Stechele W. (2010), AutoVision - Reconfigurable Hardware Acceleration for Video-Based Driver Assistance, In: Platzner, Teich, Wehn (Editors): *Dynamically Reconfigurable Systems*, ISBN 978-90-481-3484-7, Springer, 2010
- De Caro S. & Testa, A. (2009). A Power Line Communication approach for body electronics modules, *Proceeding of Power Electronics and Applications*, pp. 1-10, 978-1-4244-4432-8, Barcelona, 8-10 September 2009
- Degardin, V.; Laly, P.; Liénard, M. & Degauque, P. (2006). Impulsive Noise on In-Vehicle Power Lines: Characterization and Impact on Communication Performance, *Proceedings of IEEE International Power line Communications and Its Applications*, pp. 222-226, 1-4244-0113-5, Orlando, 26-29 March 2006.
- Degardin, V.; Lienard, M.; Degauque, P. & Laly, P. (2007). Performances of the Homeplug PHY layer in the context of in-vehicle powerline communications, *Proceedings of Power Line Communications and Its Applications*, pp. 93-97, 1-4244-1090-8, Pisa, 26-28 March 2007
- FlexRay Consortium. (2009). FlexRay Communication System, Protocol Specification, Version 2.0. Retrieved from: <http://www.flexray.com>
- Galli, S.; Koga, H. & Kodama, N. (2008). Advance signal Processing for PLCs: Wavelet OFDM, *Proceedings of Power Line Communications and Its Applications*, pp. 187-192, 978-1-4244-1975-3, Jeju city, Jeju Island, 2-4 April 2008
- Gavette, S. & al. (2006). HomePlug AV Technology Overview, *Technical report. Sharp Laboratories of America*. Retrieved from download.microsoft.com/download.
- Gouret, W.; Nouvel, F. & El Zein, G. (2006). Additional Network Using Automotive Powerline Communication, *Proceedings of International Conference on Intelligent Transport Systems Telecommunications*, pp. 1087-1092, 0-7803-9587-5, Chengdu, 26-29 March 2006
- Gouret, W.; Nouvel, F. & El Zein, G. (2007), High Data Rate Network Using Automotive Power Line, *Proceedings of International Conference on Intelligent Transport Systems Telecommunications*, pp. 1-4, 1-4244-1178-5, Sophia Antipolis, 26-28 March 2007
- IEEE P1901 (2008), IEEE P1901 Working group. Retrieved from web official web site <http://grouper.ieee.org/groups/1901/>
- Home Plug (2009). HomePlug Powerline Alliance. Retrieved from official web site www.homeplug.org
- Huck, T., Schirmer, J. & Dostert, K. (2005). Tutorial about the implementation of a vehicular high speed communication system. in *IEEE International Power line Communications and Its Applications IEEE ISPLC* , pp 162-166, 6-8 April, 2005.
- J2056/2 Survey. (1994). J2056/2 survey of known protocols. In *SAE Handbook*. Warrendale, PA: Soc. Automotive Eng. (SAE), vol. 2.
- Leen, G; Hefferman, D. (2001). Vehicles without wires. *Computing & Control Engineering Journal*, Volume. N° 12(Issue 5), October (pp. 205-21).
- Lienard, M.; Carrion, M.; Degardin, V. & Degauque, P. (2008). Modeling and Analysis on In-vehicle power line communication channels, *Proceeding of IEEE Transaction on Vehicular Technology*, vol 57, N°2, pp. 670-679, 0018-9545

- LIN Consortium. (2003). LIN Specification Package, Revision 2.0. Retrieved from <http://www.lin~subbus.org/> (2009)
- Mohammadi, M.; Lampe L.; Lok, M.; Mirabbasi, S.; Mirvakili, M.; Rosales, R. & Van Veen, P. (2009). Measurement study and transmission for in-vehicle power line communication, *Proceedings of IEEE Power Line Communications and Its Applications*, pp. 73–78, 978-1-4244-3790-0, Dresden, 29-March -1 April 2009
- Navet (2008), *The Automotive Embedded Systems Handbook, Industrial Information Technology series*, Taylor and Francis, CRC Press, ISBN 978-0849380266, 2008.
- Newman, D. (2009). Benchmarking Terminology for Firewall Performance, RFC 2647.
- Nolte, T. (2006). Share-Driven Scheduling of Embedded Networks. *University, Dissertation, May 2006. Department of Computer Science and Engineering Mälardalen University Västerås, Sweden*, Printed by Arkitektkopia, Västerås, Sweden Distribution, 2006
- Nolte, T. & Hansson H. (2009). Wireless Automotive Communications, *Internal Report* available at http://ant.comm.ccu.edu.tw/course/97_ITS/1_HW1/0.Wireless%20Automotive%20Communications.pdf, 2009
- Nouvel, F.; El Zein, G. & Citerne, J. (1994). Code division multiple access for an automotive area network over power-lines, *Proceedings of IEEE Vehicular Technology Conference*, pp. 525–529, 0-7803-1927-3, Stockholm, 8-10 June 1994.
- Nouvel, F. & Maziéro, P. (2008). X-by-Wire and intra-car communications: power line and/or wireless solutions, *Proceedings of International Conference on Intelligent Transport Systems Telecommunications*, pp. 443-448, 978-1-4244-2857-1, Phuket, 24 October 2008.
- Nouvel, F; Gouret, W; Maziéro (2009a), Automotive Network Architecture for ECUs Communications, in *Automotive Informatics and Communicative Systems: Principals in Vehicular Networks*, 28 pp, 2009, ISBN 978-160566338-8, 2009
- Nouvel F.; Tanguy, P. & Maziéro P. (2009b), What is about next high speed power line communication systems for in -vehicle networks, *Proceedings of ICICS*, pp. 533-537, 978-1-4244-4656-8, Macau, 8-10 December 2009
- OMEGA (2008), Deliverable D3.1 State of the art, application scenario and specific requirements for PLC, *OMEGA ICT-213311 Project*, FP7, Available on web site http://www.ict-omega.eu/fileadmin/documents/deliverables/Omega_D3.1.pdf
- Pham, H.-M.; Pillement S. & Demigny, D. (2009) A Fault-Tolerant Layer For Dynamically Reconfigurable Multi-Processor System-on-Chip, in *Proc. Int. Conf. on ReConfigurable Computing and FPGAs*, pp. 284–289, Cancun, Mexico, Dec. 2009.
- Pham, H.-M.; Pillement, S. & Demigny, D. (2010) Evaluation of Fault-Mitigation Schemes for Fault-Tolerant Dynamic MPSoC, in *Proc. Int. Conf. on Field Programmable Logic and Applications*, 2010
- Rubin, A. (2002). Implementing automotive protocols for communications over noisy battery power lines, *Proceedings of the IEEE Conference on Conv. Elect Electron. Eng.*, pp. 306, 1 December 2002
- Ribeiro. et al. (2006) Power Line communications : a promising communication system paradigm for last miles and meters applications, *Telecommunications : Advances and trends in transmissions*, pp. 134-154, ISBN 85-98876-18-6.
- Silva, P.; Almeida, L.; Caprini, D.; Facchinetti, T.; Benzi, F. & Nolte, T. (2009). Experiments on timing aspects of DC-powerline communications, *Proceedings of IEEE*

- international Conference on Emerging Technologies & Factory Automation*, pp. 1674-1677, 978-1-4244-2727-7, Palma de Mallorca, Spain, September 22-25 2009
- Spidcom (2008). Spidcom Inc., Retrieved from official web Official web site <http://www.spidcom.com>.
- Tanguy P.; Nouvel, F. & Maziéro, P. (2009b), Power Line Communication standards for in-vehicle networks, pp. 533-537, 978-1-4244-5347-4/09, Lilles, 20-22 October 2009
- Tanguy, P.; Nouvel, F. (2010). In-Vehicle PLC Simulator Based on Channel Measurements, in *next Proceedings of International Conference on Intelligent Transport Systems Telecommunications*, Kyoto, 9-11 November 2010.
- Umehara, D.; Morikura, M.; Hisada, T.; Ishiko S. & Satoshi, H. (2010). Statistical Impulse Detection of In-Vehicle Power Line Noise Using Hidden Markov Model, *Proceedings of Power Line Communications and Its Applications*, pp. 341-346, March 2010.
- Valéo (2006). Valéo Inc., Electrical and Electronic Distribution Systems: Focus on Power Line Communication. Retrieved from official web <http://www.valeo.com>
- Xilinx, Inc (2004). PowerPC 405 Processor Block Reference Guide, 2004
- Xilinx, Inc (2008). Early Access Partial Reconfiguration User Guide UG208, September 2008.
- Xilinx, Inc (2009). MicroBlaze Processor Reference Guide UG081 (v10.3), 2009
- Yamar, 2009, <http://www.yamar.com>, last access 20.09.2009
- Yabuuchi, Y.; Umehara, D.; Morikura, M.; Hisada, T.; Ishiko ,S. & Horihata, S. (2010). Measurement and Analysis of Impulsive Noise on In-Vehicle Power Lines, *Proceedings of Power Line Communications and Its Applications*, pp. 325-330, March 2010.
- Zhang, N.; Zhu, X.; Liu, L.; Yu, C.; Zhang, Y.; Dong, Y.; Zhang, H.; Kuai, Z. & Hong, W. 2009. Measurement and characterization of wideband channel for in-vehicle environment. In *Proceedings of the 4th international Conference on Radio and Wireless Symposium* (San Diego, CA, USA, January 18 - 22, 2009). IEEE Press, Piscataway, NJ, 183-186.

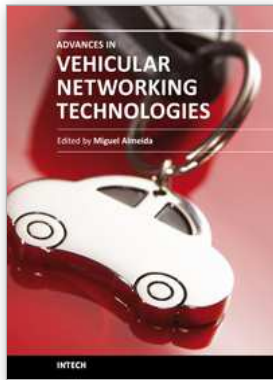

Advances in Vehicular Networking Technologies

Edited by Dr Miguel Almeida

ISBN 978-953-307-241-8

Hard cover, 432 pages

Publisher InTech

Published online 11, April, 2011

Published in print edition April, 2011

This book provides an insight on both the challenges and the technological solutions of several approaches, which allow connecting vehicles between each other and with the network. It underlines the trends on networking capabilities and their issues, further focusing on the MAC and Physical layer challenges. Ranging from the advances on radio access technologies to intelligent mechanisms deployed to enhance cooperative communications, cognitive radio and multiple antenna systems have been given particular highlight.

How to reference

In order to correctly reference this scholarly work, feel free to copy and paste the following:

Fabienne Nouvel, Philippe Tanguy, S. Pillement and H.M. Pham (2011). Experiments of In-Vehicle Power Line Communications, *Advances in Vehicular Networking Technologies*, Dr Miguel Almeida (Ed.), ISBN: 978-953-307-241-8, InTech, Available from: <http://www.intechopen.com/books/advances-in-vehicular-networking-technologies/experiments-of-in-vehicle-power-line-communications>

INTECH

open science | open minds

InTech Europe

University Campus STeP Ri
Slavka Krautzeka 83/A
51000 Rijeka, Croatia
Phone: +385 (51) 770 447
Fax: +385 (51) 686 166
www.intechopen.com

InTech China

Unit 405, Office Block, Hotel Equatorial Shanghai
No.65, Yan An Road (West), Shanghai, 200040, China
中国上海市延安西路65号上海国际贵都大饭店办公楼405单元
Phone: +86-21-62489820
Fax: +86-21-62489821

© 2011 The Author(s). Licensee IntechOpen. This chapter is distributed under the terms of the [Creative Commons Attribution-NonCommercial-ShareAlike-3.0 License](#), which permits use, distribution and reproduction for non-commercial purposes, provided the original is properly cited and derivative works building on this content are distributed under the same license.