

Condensation Capture of Fine Dust in Jet Scrubbers

M.I. Shilyaev and E.M. Khromova

*Department of heating and ventilation,
Tomsk State University of Architecture and Building
Russia*

1. Introduction

Dust particles with a size of hundredths and tenths of a micron can be hardly separated from the cleaned gas flow in the inertial dust catchers without their preliminary agglomeration. This processing can be carried out in the sound field; as a result of this processing the small particles become significantly larger because of acoustic coagulation (according to (Uzhov & Valdberg, 1972), soot particles with a size of $0.03 \mu\text{m}$ enlarge to $5 \mu\text{m}$) or because of condensation of water vapors on these particles. In the last case efficient dust capture is provided by a rise of inertia of particles, where water vapors condense during particle motion in the working section of apparatus, and, hence, by a rise of probability of their collision with droplets of irrigating fluid (Fig. 1), for instance, in jet scrubbers. Thus, at soot capture from cracked gases in the counter-flow jet scrubber (Fig. 2) the efficiency of about 90% was achieved at high inlet moisture content in gases (about 1 kg/kg of dry gases) (Uzhov & Valdberg, 1972, Shilyaev et al., 2006). The conditions of intensive vapor condensation on particles should be achieved already at the inlet; and reliable prognosis and optimization of dust capture require the adequate mathematical models. It can be scarcely determined in experiment. Some generalizing experimental data on condensation dust capture in different devices of the wet type are shown in (Uzhov & Valdberg, 1972, Valdberg & Savitskaya, 1993). However, it is shown in (Shilyaev et al., 2008) that in these devices it is wrong to generalize dust capture efficiency vs. moisture content by a single dependence (as it was done in the mentioned papers) because the processes of dust capture there are determined by different mechanisms (Shilyaev et al., 2006).

The authors failed to find well-grounded theoretical publications on combined heat and mass transfer and condensation dust capture on droplets in jet scrubbers. The attempt of such modeling is shown in (Pazhi & Galustov, 1984), one of the chapters of this book presents one-dimensional model, but unfortunately, it is shown with numerous misprints and it is difficult to understand. According to equations, the moisture content and thermodynamics of the vapor-gas flow were not considered in general in connection with heat and mass transfer with particles and droplets. Therefore, well-illustrated correlation between calculations and experimental data on dust capture causes some doubts. At that, there is no the description of experimental conditions and required physical, operation, and geometrical parameters.

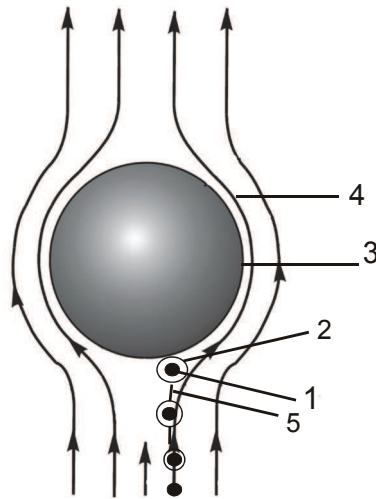

Fig. 1. The scheme of interaction of a particle with condensate on the surface with a droplet of irrigating fluid: 1 - particle; 2 - condensate on particle surface; 3 - droplet; 4 - stream line of the vapor-gas flow; 5 - formation trajectory of a particle with condensate on the surface

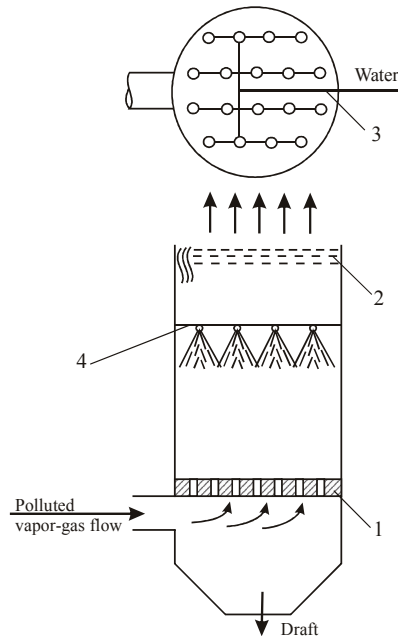

Fig. 2. The scheme of the counter-current hollow jet scrubber: 1 - gas-distributing grid; 2 - droplet-catcher; 3 - water collector; 4 - jets

The above-mentioned data prove the necessity of more complete and accurate statement of the discussed problem.

The current paper represents the main points and results of implementation of the physical-mathematical model on condensation capture of submicron particles in jet scrubbers, occurring by the inertial mechanism, proved by the experimental data of (Uzhov & Valdberg, 1972).

2. Main assumptions and equations of the model

The current model was based on the model of heat and mass transfer of fluid droplets with the vapor-gas flow in irrigation chamber (Shilyaev & Khromova, 2008, Shilyaev et al., 2008). It was modified by addition of the equation of particle motion, continuity equation for their "spread" density (mass concentration), which considers the effect of collision of particles with condensate on the surface, and equations of heat and mass transfer of new formations with the vapor-gas flow. At that, we have considered a change in the mass of irrigating fluid droplets both via mass transfer with the vapor-gas flow and precipitation of formations on their surface. The equation of droplet heat transfer considers both the latent heat of phase transition on droplet surface and heat transfer of new formations due to their precipitation on droplets. The equation of moisture content considers the mass fluxes from new formations together with the mass fluxes caused by fluid evaporation (vapor condensation) from (on) droplets. The continuity equation for the "spread" density of irrigating fluid takes into account a change in its mass both due to total phase transition on droplets and formations and due to absorption of formations by droplets at their collision. The scheme of collision of droplet and particle with condensate on the surface is shown in Fig. 1.

In general we consider the motion and heat and mass transfer of the three-phase four-component heterogeneous medium of fluid droplets-monodispersed submicron solid particles-vapor-gas mixture in the hollow scrubbers with jet irrigation in the framework of the model of various-temperature and various-velocity continua. At that, considering the small size of particles with condensate on the surface, their motion with the vapor-gas mixture is assumed dynamically equilibrium, but temperature-unbalanced. This model takes into account condensation of vapors on droplets and particles or evaporation depending on local thermodynamics parameters in the vapor-gas flow. The effect of precipitation of particles with condensate on the surface on droplets is taken into account with the help of capture coefficient, determined by the empirical formula of Langmuir-Blodgett. It is known that the higher the content of vapor in gas, the more efficient the process of fine particle capture in the scrubber. Therefore, the current model takes into account the effect of increased moisture content on mass transfer of droplets and particles with condensate on their surface by the correction for the Stefan flow. Volumetric concentrations of droplets and particles are assumed low, what is typical for operation of scrubbers and irrigation chambers of air-conditioning units; therefore, the equations of liquid and solid phase motion in the framework of continuum model are turned to the motion equations for separate droplets and particles. At that, we consider that the droplets and submicron particles are monodispersed, with some, for instance, mean-mass diameter.

The model presentation of the problem is shown in Fig. 3. This schematic view of irrigation chamber was chosen to formulate the model equations in more general form, considering that the chambers can be horizontal ($\beta=0$) or vertical ($\beta=\pi/2$) or even inclined at unconditioned angle. The counter-flow jet scrubbers are vertical, irrigation chambers of air-

conditioning units are horizontal (predominantly) and vertical (sometimes), Venturi tubes are horizontal, vertical and inclined at unconditioned angle (in battery arrangement). In Venturi scrubber dust is captured in the diffuser (diverging) part of Venturi tube, which should be taken into account in the equation of the vapor-gas flow velocity. At that, the scheme can be counter-flow a) and direct-flow b), what is determined by supply of fluid and vapor-gas flow. In the counter-flow scheme a) fluid is fed from one side with the following initial parameters: Θ_0 is droplet temperature, $q = Q_f/Q$ is irrigation coefficient (Q_f and Q are volumetric flow rates of fluid and vapor-gas flow), δ_{d0} is mean-mass size of droplets generated by jets and calculated via the jet parameters (Uzhov & Valdberg, 1972, Pazhi & Galustov, 1984, Vitman et al., 1962), V_{d0} is the initial velocity of droplets also calculated via jet parameters. The vapor-gas mixture with small particles is fed from the opposite side with the following initial parameters: T_{00} , d_0 , U_0 are temperature, moisture content and velocity of the vapor-gas flow. In direct-flow scheme b) fluid and vapor-gas mixture and particles are fed from one side. At interaction the particles with condensate on the surface collide with droplets, absorbed by them and entrained into sludge.

Let's write down model equations in the general vector form.

The equation of droplet motion with consideration of their mass variability because of condensation or evaporation and absorption of formations by droplet is

$$\frac{d\vec{V}_d}{d\tau} = \vec{g} + \vec{R}_d - \frac{\vec{V}_d}{m_d} \frac{dm_d}{d\tau}, \tag{1}$$

where \vec{V}_d , m_d , \vec{R}_d is velocity vector, droplet mass and vector of aerodynamic resistance acting on the droplet per a unit of its mass, and \vec{g} is vector of gravity acceleration, τ is time. The motion equation for particles with condensate on the surface is (equilibrium is assumed because of the small size of formations)

$$\vec{V}_{pf} = \vec{U}, \tag{2}$$

where \vec{V}_{pf} and \vec{U} are velocity vectors of formations and vapor-gas flow.

The continuity equation for irrigating fluid is

$$\frac{d\rho_d}{d\tau} = \frac{\rho_d}{m_d} \frac{dm_d}{d\tau} - \rho_d \nabla \vec{V}_d, \tag{3}$$

where ρ_d is "spread" density of droplets.

The equation of mass transfer of fluid droplet with the flow of vapor-gas mixture due to evaporation-condensation and with particles due to their precipitation on droplets is

$$\frac{dm_d}{d\tau} = \frac{2\pi M_1 K_s D \delta_d}{RT} (P_1 - P_{1d}) \Phi + \rho_{pf} V_r \frac{\pi \delta_d^2}{4} \eta_{sk}, \tag{4}$$

or

$$\frac{dm_d}{d\tau} = \beta_d \pi \delta_d^2 (\rho_1 - \rho_{1d}) + \rho_{pf} V_r \frac{\pi \delta_d^2}{4} \eta_{sk}, \tag{4'}$$

where M_1 is molecular mass of vapor (for steam $M_1=18$ kg/kmole), D is coefficient of vapor diffusion in mixture, δ_d is current size of the droplet, $R=8.314 \cdot 10^3$ kJ/kmole K is universal gas constant, T is absolute temperature of the vapor-gas flow, P_1 and P_{1d} are partial pressures of vapors far from the droplet and on its surface, corresponding to saturation temperature, which equals temperature of droplet surface Θ_s , K_s is correction for the Stefan flow at high moisture contents (Uzhov & Valdberg, 1972, Amelin, 1966):

$$K_s = 1 + \frac{P_1 + P_{1d}}{2B},$$

$B = P_1 + P_2$ is barometric pressure, P_2 is partial pressure of dry gas in the flow, and Φ is Frossling correction for the inertia of the flow past the droplet (Shilyaev et al., 2006):

$$\Phi = 1 + 0,276Re_d^{0,5} \cdot Sc^{0,33},$$

Re_d is Reynolds number of the flow past the droplet:

$$Re_d = \frac{V_r \delta_d \rho}{\mu},$$

Sc is Schmidt number:

$$Sc = \frac{\mu}{\rho D},$$

$V_r = |\vec{V}_d - \vec{U}|$ is absolute value of relative droplet velocity, ρ and μ are density and dynamic viscosity of the vapor-gas mixture, ρ_{pf} is "spread" density of particle formations with condensate on the surface, η_{stk} is coefficient of formation capture by fluid droplets, β_d is mass transfer of a droplet by concentration difference of vapors, ρ_1 and ρ_{1d} are partial densities (mass concentrations of vapor) far from the droplet and near its surface, calculated from state equations

$$\rho_1 = \frac{P_1 M_1}{RT}, \quad \rho_{1d} = \frac{P_{1d} M_1}{R\Theta_s}.$$

The equation of mass transfer of particle formation with condensate on the surface with the flow of vapor-gas mixture (Maxwell equation) is

$$\frac{dm_{pf}}{d\tau} = \frac{2\pi M_1 K_s D \delta_{pf}}{RT} (P_1 - P_{1p}), \tag{5}$$

or

$$\frac{dm_{pf}}{d\tau} = \beta_{pf} \pi \delta_{pf}^2 (\rho_1 - \rho_{1p}), \tag{5'}$$

where m_{pf} is mass of formation, δ_{pf} is diameter of formation, P_{1p} is partial pressure of vapors near the formation surface, calculated by its temperature T_{pf} corresponding to saturation

temperature, β_{pf} is coefficient of formation mass transfer by concentration difference, and ρ_{1p} is partial density of vapors near the formation surface, calculated from the equation of state

$$\rho_{1p} = \frac{P_1 M_1}{RT_{pf}}.$$

The continuity equation for particles with condensate on the surface with consideration of their precipitation on droplets of irrigating fluid is

$$\frac{d\rho_{pf}}{d\tau} = \frac{\rho_{pf}}{m_{pf}} \frac{dm_{pf}}{d\tau} - \rho_{pf} \nabla \bar{U} - \rho_{pf} V_r \frac{\pi \delta_d^2}{4} \eta_{sk} \frac{\rho_d}{m_d}, \quad (6)$$

where $\rho_d/m_d = n_d$ is calculating droplet concentration in the vapor-gas flow.

The continuity equation for dry particles with consideration of precipitation of particle formation with condensate on the surface on droplets of irrigating fluid is

$$\frac{d\rho_p}{d\tau} = -\rho_p \nabla \bar{U} - \rho_p V_r \frac{\pi \delta_d^2}{4} \eta_{sk} \frac{\rho_d}{m_d}, \quad (7)$$

where ρ_p is "spread" density of dry particles in the flow.

The equation for moisture content of the vapor-gas flow is

$$\frac{dd}{d\tau} = \frac{W}{(1 - \varepsilon_{dp}) \rho_2}, \quad (8)$$

where d is moisture content made up of the mass of fluid vapors per one kilogram of dry part of gas in the mixture,

$$\rho_2 = \frac{P_2 M_2}{RT},$$

ρ_2 is partial density of dry gases in the flow, M_2 is molecular mass of dry gases (for air $M_2=29$ kg/kmole), ε_{dp} is total volumetric concentration of droplets and particles in the flow, as usual $\varepsilon_{dp} \ll 1$, W is the total mass withdrawal (condensation), income (evaporation of droplets and formations) of fluid vapors in the flow per a time unit in a volume unit of the vapor-gas mixture:

$$W = - \left[\frac{dm'_d}{d\tau} \frac{\rho_d}{m_d} + \frac{dm_{pf}}{d\tau} \frac{\rho_{pf}}{m_{pf}} \right],$$

where

$$\frac{dm'_d}{d\tau} = \frac{2\pi M_1 K_s D \delta_d}{RT} (P_1 - P_{1d}) \Phi,$$

or

$$\frac{dm'_d}{d\tau} = \beta_d \pi \delta_d^2 (\rho_1 - \rho_{1d}).$$

The equation for velocity of the vapor-gas mixture along chamber axis x (Shilyaev & Khromova, 2008) is

$$U = U_0 \frac{T}{T_{00}} \frac{K+d}{K+d_0}, \tag{9}$$

where $K = M_1/M_2$.

The equation of heat transfer of a droplet with the vapor-gas mixture flow is

$$c_d m_d \frac{d\Theta}{d\tau} = -\alpha_d \pi \delta_d^2 (\Theta_s - T) + r_f \frac{dm'_d}{d\tau} + c_{pf} \rho_{pf} V_r \frac{\pi \delta_d^2}{4} \eta_{sk} T_{pf}, \tag{10}$$

where Θ is mean-mass temperature of droplet, Θ_s is temperature of droplet surface, c_d is heat capacity of droplet together with absorbed particles, then we will assume it equal to fluid heat capacity c_f because of low concentration of particles, r_f is specific heat of the phase transition evaporation-condensation, then we will assumed $c_{pf} = c_f$.

The equation of heat transfer between particle formations with condensate on the surface and the flow of vapor-gas mixture is

$$c_{pf} m_{pf} \frac{dT_{pf}}{d\tau} = -\alpha_{pf} \pi \delta_{pf}^2 (T_{pf} - T) + r_f \frac{dm_{pf}}{d\tau}, \tag{11}$$

where α_{pf} is heat transfer of formation.

The equation for the temperature of vapor-gas mixture is

$$\rho \frac{dcT}{d\tau} = \alpha_d \pi \delta_d^2 (\Theta_s - T) \frac{\rho_d}{m_d} + \alpha_{pf} \pi \delta_{pf}^2 (T_{pf} - T) \frac{\rho_{pf}}{m_{pf}}. \tag{12}$$

where c is heat capacity of the vapor-gas mixture.

Equations (1)-(12) should be solved under the following initial conditions:

$$\text{at } \tau = 0 \quad \vec{V}_d = \vec{V}_{d0}, \vec{U} = \vec{U}_0, \rho_d = \rho_{d0}, m_d = m_{d0}, m_{pf} = m_{p0}, \rho_{pf} = \rho_{p0}, d = d_0, \Theta = \Theta_0, T = T_{00} \tag{13}$$

The model equations can be solved in the stationary statement in the Euler coordinate system for direct flow (assignment of initial conditions for the droplets of irrigating fluid, vapor-gas mixture and particles on one side of the apparatus at $x=0$) and for counter flow (assignment of initial conditions for the droplets of irrigating fluid on one side of the apparatus at $x=0$, and for the vapor-gas mixture and particles on another side at $x=l$). At that

$$\frac{\partial}{\partial t} = 0 \text{ and}$$

$$\frac{d_i(\dots)}{d\tau} = \vec{V}_i \nabla(\dots), \tag{14}$$

where index i determines substantial derivative. If axis x coincides with apparatus axis and direction of the vapor-gas flow, relationship (14) is

$$\begin{aligned} \frac{d\bar{V}_d}{d\tau} &= \bar{V}_d \nabla \bar{V}_d, \quad \frac{d\rho_d}{d\tau} = \bar{V}_d \nabla \rho_d, \quad \frac{dm_d}{d\tau} = \bar{V}_d \nabla m_d, \quad \frac{dm_{pf}}{d\tau} = \bar{U} \nabla m_{pf} = U \frac{\partial m_{pf}}{\partial x}, \\ \frac{d\rho_{pf}}{d\tau} &= \bar{U} \nabla \rho_{pf} = U \frac{\partial \rho_{pf}}{\partial x}, \quad \frac{d\rho_2}{d\tau} = \bar{U} \nabla \rho_2 = U \frac{\partial \rho_2}{\partial x}, \quad \frac{dd}{d\tau} = \bar{U} \nabla d = U \frac{\partial d}{\partial x}, \quad \frac{d\Theta}{d\tau} = \bar{V}_d \nabla \Theta, \\ \frac{dT_{pf}}{d\tau} &= \bar{U} \nabla T_{pf} = U \frac{\partial T_{pf}}{\partial x}, \quad \frac{d(cT)}{d\tau} = \bar{U} \nabla (cT) = U \frac{\partial (cT)}{\partial x}. \end{aligned}$$

The efficiency of dust particle capture is determined by expression:

$$\eta = 1 - \frac{1}{h\rho_{p0}U_0} \int_0^h (\rho_p U)_{x=l} dy, \quad (15)$$

where h is chamber height (width).

In equation (1) and then, if we assume droplet spherical,

$$m_d = \frac{\pi \delta_d^3}{6} \rho_f, \quad (16)$$

where ρ_f is density of irrigating fluid, and δ_d is droplet diameter. With consideration of gravity forces in the coordinate system of Fig. 3 the velocity vector of irrigating fluid droplets has two components V_{dx} and V_{dy} . The strength of aerodynamic drag \bar{R}_d , effecting the droplet, per a unit of its mass is:

$$\bar{R}_d = \tilde{\xi}_d \frac{(\bar{V}_d - \bar{U})}{\tau_d}, \quad (17)$$

where

$$\tau_d = \frac{\rho_f \delta_d^2}{18\mu}. \quad (18)$$

In (17) $\tilde{\xi}_d = \xi_d / \xi_s$ is relative coefficient of droplet resistance, ξ_d is actual coefficient of droplet resistance, and $\xi_s = 24 / \text{Re}_d$ is Stokes coefficient of droplet resistance.

The density of vapor-gas flow is determined as the sum of partial densities of mixture components:

$$\rho = \rho_1 + \rho_2. \quad (19)$$

The dynamic viscosity of vapor-gas flow is calculated through the partial pressure of binary mixture components (Shilyaev & Khromova, 2008), or on the basis of molecular-kinetic theory of gases (Shilyaev et al., 2008).

Let's take relative resistance coefficient $\tilde{\xi}_d$ by the known approximation dependence, valid for a wide range of Reynolds numbers $\text{Re}_d = 0,1 - 3 \cdot 10^5$ (Shilyaev et al., 2006):

$$\tilde{\xi}_d = 1 + 0,197 \text{Re}_d^{0,63} + 2,6 \cdot 10^{-4} \text{Re}_d^{1,38}. \quad (20)$$

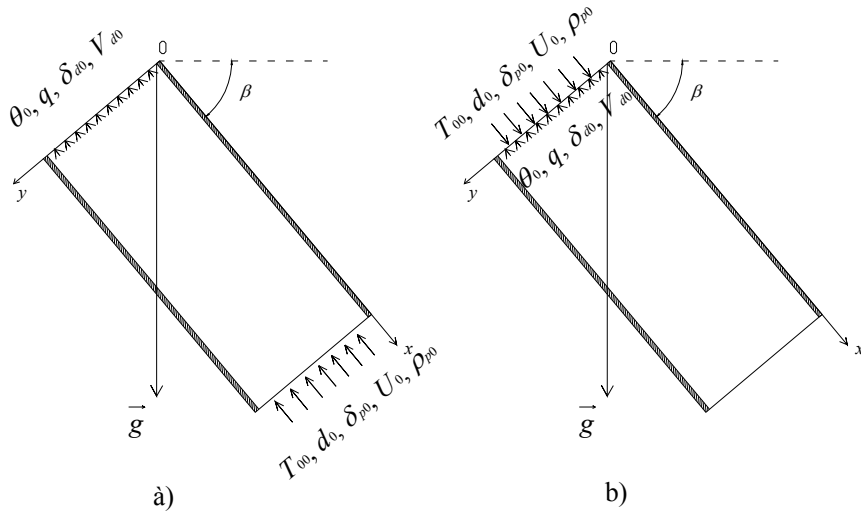

Fig. 3. The schemes of irrigation chambers: a) – counter flow; b) – direct flow

Let's take capture coefficient η_{Stk} , determining efficiency of precipitation of particle formations with condensate on their surface on droplets of irrigating fluid by empirical dependence of Langmuir-Blodgett with the correction of N.A. Fuks for the capture effect (Shvydkiy & Ladygichev, 2002):

$$\eta_{Stk} = \left(\frac{Stk}{Stk + 0,5} \right)^2 + 2,5 \frac{\delta_{pf}}{\delta_d}, \tag{21}$$

where Stk is Stokes number:

$$Stk = \tau_\delta \frac{V_r}{\delta_d}, \quad \tau_\delta = \frac{\rho_f \delta_{pf}^2}{18\mu}. \tag{22}$$

The second summand in equation (21) determines the capture effect.

In equation (4') β_d is coefficient of droplet mass transfer with the vapor-gas flow by concentration difference of vapors $\Delta\rho = \rho_1 - \rho_{1d}$, $\rho_{1d} = P_{1d}(\Theta_s)M_1/R\Theta_s$ (in calculations we will assume $\Theta_s \approx \Theta$, what is reasonable, as it is shown in (Shilyaev & Khromova, 2008), for droplets with the size of up to 600-800 μm):

$$\beta_d = 2 \frac{D}{\delta_d} K_s \Phi. \tag{23}$$

In equation (5) m_{pf} is mass of formation:

$$m_{pf} = \frac{\pi\delta_{pf}^3}{6} \rho_{pf}^0 \approx \frac{\pi\delta_{pf}^3}{6} \rho_f. \tag{24}$$

where ρ_{pf}^0 is averaged density of formation, then, we will assume $\rho_{pf}^0 \approx \rho_f$.

In equation (5) β_{pf} is coefficient of formation mass transfer with the vapor-gas flow:

$$\beta_{pf} = 2 \frac{D}{\delta_{pf}} K_s. \quad (25)$$

In equation (10) we determine the coefficient of droplet heat transfer a_d by Drake formula:

$$\text{Nu}_d = \frac{\alpha_d \delta_d}{\lambda} = 2 + 0,495 \text{Re}_d^{0,55} \text{Pr}^{0,33}, \quad (26)$$

Nu_d is Nusselt number of heat transfer, λ is coefficient of heat conductivity for the vapor-gas mixture calculated by partial pressures (Shilyaev & Khromova, 2008) or on the basis of molecular-kinetic theory of gases for the binary mixture (Shilyaev et al., 2008), $\text{Pr} = \frac{\mu c}{\lambda}$,

where c is heat capacity of the vapor-gas flow:

$$c\rho = c_1\rho_1 + c_2\rho_2, \quad (27)$$

then

$$c = \frac{c_1 d + c_2}{1 + d}, \quad (28)$$

since by equation

$$d = \frac{\rho_1}{\rho_2}, \quad (29)$$

c_1 and c_2 are heat capacities of vapor and dry gas (for steam $c_1=1.8$ kJ/kg·K, for air $c_2=1.005$ kJ/kg·K).

The second summand in the right part of (10) is latent heat of phase transition of droplet evaporation or condensation of vapors on the droplet, the third summand in the right part is heat transferred by formations on the droplet. Let's determine heat transfer coefficient of formation a_{pf} by equation

$$\alpha_{pf} = 2 \frac{\lambda}{\delta_{pf}} \quad (30)$$

because of its small size.

Equation (12) describes a change in enthalpy per a time unit in a volume unite of the vapor-gas flow because of its convective heat transfer with droplets of irrigating fluid and formations.

The initial condition for mass concentration of fluid is set as

$$\rho_{d0} = q\rho_i \frac{U_0}{V_{d0}}. \quad (31)$$

The condition of vapor condensation on particles follows from the equation of mass transfer, for instance, (5): $\rho_1 - \rho_{1p} > 0$, then $dm_{pf}/d\tau > 0$. This condition can be written at $\tau=0$ in the form $\left(\frac{P_1 M_1}{RT_{00}} - \frac{P_{1p}(T_{00}) M_1}{RT_{00}} \right)_{\tau=0} > 0$, or $P_1 - P_{1p} > 0$.

Since from state equation $P_1 = B \frac{d_0}{K + d_0}$, $P_{1p} = B \frac{d_{1p}}{K + d_{1p}}$, d_{1p} is moisture content determined by temperature at chamber inlet T_{00} , the condition for the beginning of liquid vapor condensation on particles takes form

$$d_0 > K \frac{a}{1 - a}, \tag{32}$$

where

$$a = \frac{P_{1p}(T_{00})}{B}. \tag{33}$$

For instance, for steam and air at $B=101325$ Pa, $T_{00}=333$ K (60 °C), $P_{1p}=0.199 \cdot 10^5$ Pa, $K=18/29=0,621$. Then, $a=0.1964$ and $d_0 > 0.152$ kg/kg of dry air. Therefore, condition (32) should be taken into account at realization of the above problem.

3. Comparison of calculation results with experimental data

Results of model implementation for the experimental data on soot capture in the jet scrubber by the method of methane electric cracking from cracked gases are shown in Fig. 4. On the basis of data from (Uzhov & Valdberg, 1972), we managed to determine approximately the physical parameters of cracked gases through the comparison with the molecular weights of the known gases: $M_g = 11.24$ kg/kmole is molecular mass; $c_g = 2.4$ kJ/kg · K is specific heat capacity at constant pressure; coefficients of dynamic viscosity are

$$\mu_g = 6,47 \cdot 10^{-6} \left(\frac{T}{T_0} \right)^{1,7}, \text{ Pa s, } T_0 = 273 \text{ K,} \tag{34}$$

and coefficients of heat conductivity are

$$\lambda_g = 1,34 \cdot 10^{-2} \left(\frac{T}{T_0} \right)^{1,7}, \text{ W/m} \cdot \text{K,} \tag{35}$$

coefficient of steam diffusion in cracked gases is:

$$D_0 = 13,1 \cdot 10^{-6} \left(\frac{T}{T_0} \right)^{3/2}, \text{ m}^2/\text{s.} \tag{36}$$

Calculations have been carried out for the following conditions (Uzhov & Valdberg, 1972, Table XIII.1, p.221):

- inlet gas temperature - $t_0 = 160 - 180^\circ \text{C}$;

- outlet gas temperature - $t_{out} = t(H) = 50 - 55^{\circ} \text{C}$;
- inlet velocity of vapor-gas flow - $U_0 = 0,25 \text{ m/s}$;
- irrigation coefficient - $q = 7,1 \cdot 10^{-3} \text{ m}^3/\text{m}^3$;
- inlet soot concentration - $\rho_{p0} = 1.72 \text{ g/m}^3 (2.8 \text{ g/m}^3 (\text{normal conditions}))$;
- outlet soot concentration - $\rho_{pout} = \rho_p(H) = 0.356 \text{ g/m}^3 (0.425 \text{ g/m}^3 (\text{normal conditions}))$;
- inlet water temperature - $\theta_0 = 20^{\circ} \text{C}$;
- scrubber diameter - $D = 3 \text{ m}$;
- scrubber height - $H = 12,75 \text{ m}$;
- water pressure on jets (evolvent) - $P_f = 300 \text{ kPa}$;
- jet nozzle diameter - $d_n = 12 \text{ mm}$;
- density of cracked gases under normal conditions - $\rho_g = 0,51 \text{ kg/m}^3 (\text{normal conditions})$.

Approximated calculation of the size of irrigating fluid droplets by (Uzhov & Valdberg, 1972) gives the values of mean-mass diameter $\delta_{d0} = 700 \mu\text{m}$ and initial velocity of droplets $V_{d0} = 24,5 \text{ m/s}$. The estimate of moisture content difference by empirical data of (Uzhov & Valdberg, 1972) allowed determination of $\Delta d = 0,849 \text{ kg/kg}$ of dry air for the given experiment. Exhaustive search of inlet moisture contents (there is no d_0 in experimental data) for determination of experimental value $\Delta d \approx 0.85 \text{ kg/kg}$ of dry gas in calculations allows us to take $d_0 = 0.93 \text{ kg/kg}$ of dry gas. In calculations we have also taken the initial size of soot particles $\delta_{p0} = 0.1 \mu\text{m}$.

Let's determine the efficiency values by the ratio of mass flow rates of particles at the scrubber outlet and inlet by formula (15) with consideration of dependence (9):

$$\eta = 1 - \frac{\rho_p(H) \cdot U(H)}{\rho_{p0} \cdot U_0} = 1 - \frac{0,356}{1,72} \frac{T(H)}{T_{00}} \frac{K + d(H)}{K + d_0} =$$

$$= 1 - \frac{0,356}{1,72} \frac{325,2}{443} \frac{\left(\frac{18}{11,24} + 0,081\right)}{\left(\frac{18}{11,24} + 0,93\right)} = 0,899 \text{ (89,9\%)}$$

where $d(H)$ and d_0 are taken by calculation because there is no experimental value of velocity $U(H)$ in [1], $\rho_p(H)$ and ρ_{p0} are real concentrations of particles at scrubber outlet and inlet, and temperatures $T(H)$ and T_{00} are assumed average from data presented.

The theoretical value of efficiency for the given version of calculation is $\eta = 89.3 \%$, and the diagrams in Fig. 4 prove that.

Calculation results on parameters described by the suggested model are shown in Fig. 4. According to the diagrams, the "spread" density (mass concentration) of dry particles increases drastically at first, then it starts decreasing slowly. An increase is caused by a fast reduction in velocity of the vapor-gas flow because of a significant withdrawal of vapors via their condensation of droplets and particles; then particles with condensation on the surface are entrapped by droplets and dust concentration in the flow decreases. In this case the size of particles increases by the factor of 3.5; i.e., their mass increases by the factor of 43.

Calculated outlet gas temperatures differ significantly from the experimental ones, and we suppose that this is connected with uncertainty of assignment of initial moisture content and averaging of temperature within 20°C from the measured values.

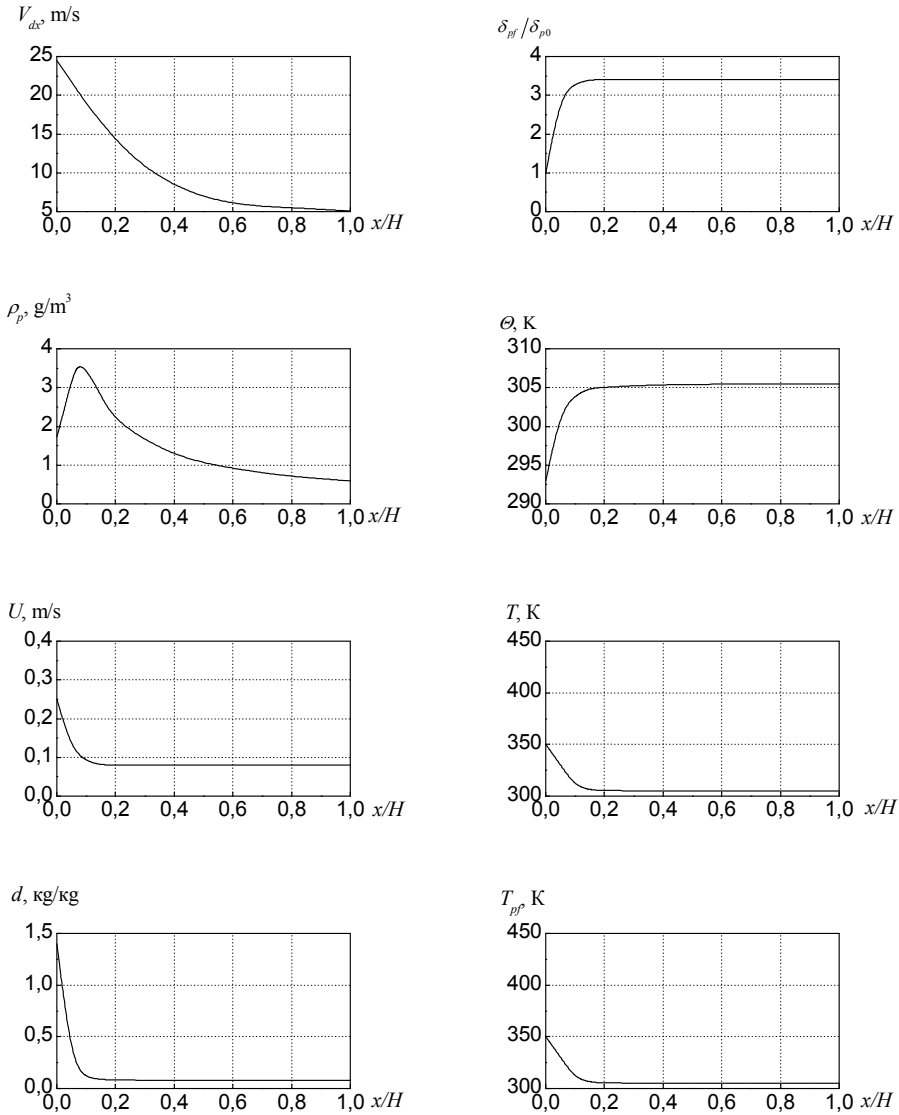

Fig. 4. Results of model calculations: $H=12.75$ m, $q=7.1 \cdot 10^{-3}$ m³/m³, $\delta_{d0}=7 \cdot 10^{-4}$ m, $V_{d0}=24.5$ m/s, $\Theta_0=293$ K, $T_{00}=443$ K, $d_0=0.93$ kg/kg, $U_0=0.25$ m/s, $\delta_{d0}=10^{-7}$ m, $\rho_{p0}=1.72$ g/m³

As we can see, the theoretical results correlate well with the experimental values, what proves model efficiency.

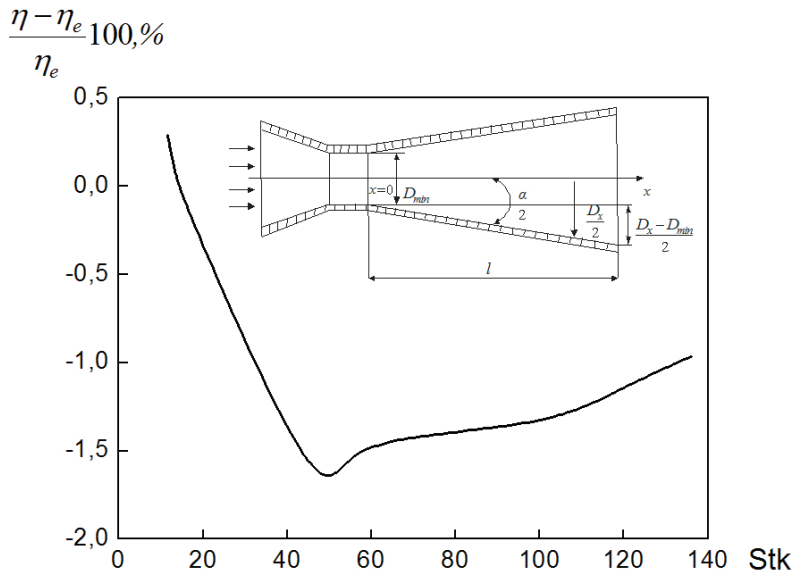

Fig. 5. Comparison of model with experimental data under isothermal conditions for Venturi scrubber: η was determined by formula (15) and η_e - by formula (37)

To assure additionally efficiency of the model, the process of dust capture on water droplets from air was calculated with the use of this model under the isothermal conditions (at $t=20$ °C) without mass transfer in a standard Venturi tube (Uzhov & Valdberg, 1972). Calculation results are compared in Fig. 5 with the experimental data described by the known dependence of fractional efficiency on Stokes number (Uzhov & Valdberg, 1972)

$$\eta_e = 1 - e^{-q \cdot 10^{-3} b \sqrt{\text{Stk}}}, \quad \text{Stk} = \frac{\rho_p^0 \delta^2 V_{r0}}{18 \mu \delta_{d0}}, \quad (37)$$

at $q=0.5 \cdot 10^{-3} \text{ m}^3/\text{m}^3$, $b=1.5$ (b is constructive parameter: $b=1.25-1.56$ (Uzhov & Valdberg, 1972, Shilyaev et al., 2006)). Difference in a wide range of Stokes numbers Stk does not exceed 2%. In calculations velocity of the vapor-gas flow was determined by formula

$$U = U_0 \frac{T}{T_{00}} \frac{K + d}{K + d_0} \left(\frac{D_{\min}}{D_x} \right)^2, \quad (38)$$

where U_0 is velocity of the vapor-gas flow in the throat of tube with diameter D_{\min} , D_x is the current diameter of diffuser:

$$D_x = D_{\min} + 2x \text{tg} \frac{\alpha}{2},$$

α is diffuser angle, and x is coordinate along the tube axis. The size of fluid droplets, fed into the tube throat, was calculated by formula of Nukiyama-Tanasava (Shilyaev et al., 2006, Shvydkiy & Ladygichev, 2002):

$$\delta_{d0} = \frac{0,585}{V_{r0}} \sqrt{\frac{\sigma_f}{\rho_f}} + 53,4 \left(\frac{\mu_f}{\sqrt{\rho_f \sigma_f}} \right)^{0,45} q^{1,5}, M, \tag{39}$$

where σ_f is coefficient of surface tension of fluid (for water $\sigma_f=0.072$ N/m), ρ_f is fluid density (for water $\rho_f=10^3$ kg/m³), μ_f is coefficient of dynamic viscosity of fluid (for water $\mu_f=10^{-3}$ Pa s at $t=20$ °C), $V_{r0} = |V_g - V_{d0}|$, V_g is gas velocity in the throat of Venturi tube, and V_{d0} is velocity of droplets in the throat of Venturi tube, assumed equal to 4-5 m/s. The density of particles was taken conditionally $\rho_p^0 = 10^3$ kg/m³. The diameter of tube throat was taken $D_{min}=0.1$ m, length of diffuser part was $l=1$ m, and angle was $a=6^0$.

4. Condensation effect of single particle enlargement in irrigation chamber

Results of model (Shilyaev et al., 2008) implementation together with mass transfer equation for a single submicron droplet (5') under the condition of fluid vapor condensation on it (32) are shown in Figs. 6-9 for the air-water system (calculations have been carried out at $T_{00}=333$ K, $\delta_{d0}=500$ μm, $q=0.001$ m³/m³, $\Theta_0=293$ K, $U_0=3$ m/s, $V_{d0}=12$ m/s; q is coefficient of irrigation; $V_{d0}, U_0, \Theta_0, T_{00}$ are inlet velocities and temperatures of irrigating fluid droplets and vapor-gas flow; δ_{d0} is initial size of irrigating fluid droplets; δ_0 is initial size of submicron droplet; d_0 is moisture content at the inlet to the chamber; and l is chamber length). The effect of collision between submicron droplet and irrigating fluid droplet was not taken into account.

According to Figs. 6 and 7, at high moisture contents the condensation effect is very strong and inverse to initial size δ_0 . The droplet size for $\delta_0=0.1$ μm increases by the factor of 450 up to 45 μm, for $\delta_0=0.01$ μm it increases by 4500 times up to the same size. These formations can be efficiently captured even independently in vortex drop catchers.

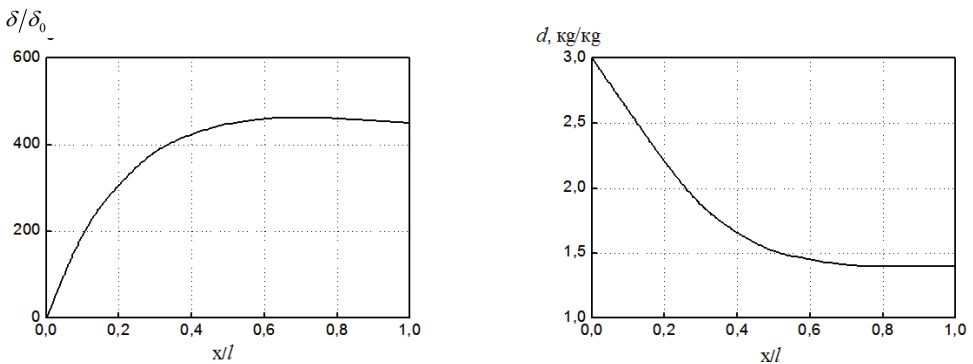

Fig. 6. Condensation of fluid vapors in a vertical chamber in direct flow on droplet with size $\delta_0=10^{-7}$ m: $l=2$ m, $d_0=3$ kg/kg of dry air

Results of calculations under outstanding conditions of condensation (32) are shown in Fig. 8. In this case critical value is $d_0=0.15$ kg/kg of dry air. According to the figure, the droplet with initial size $\delta_0=0.1$ μm evaporates along the whole chamber and disappears almost at the chamber inlet.

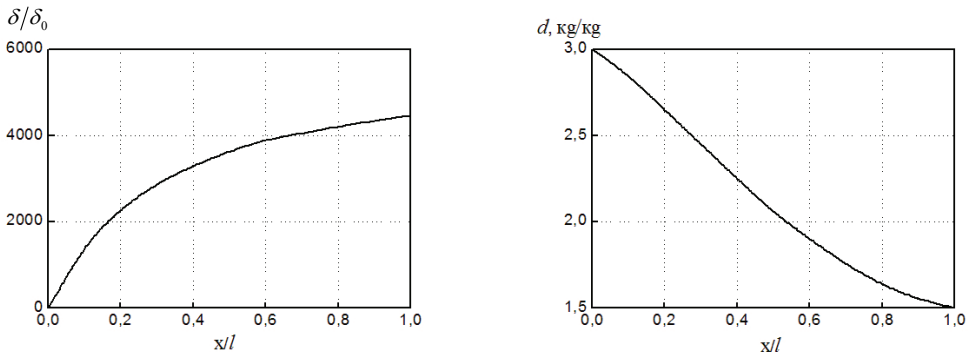

Fig. 7. Condensation of fluid vapors in a vertical chamber in direct flow on droplet with size $\delta_0=10^{-7}$ m; $l=1$ m, $d_0=3$ kg/kg of dry air

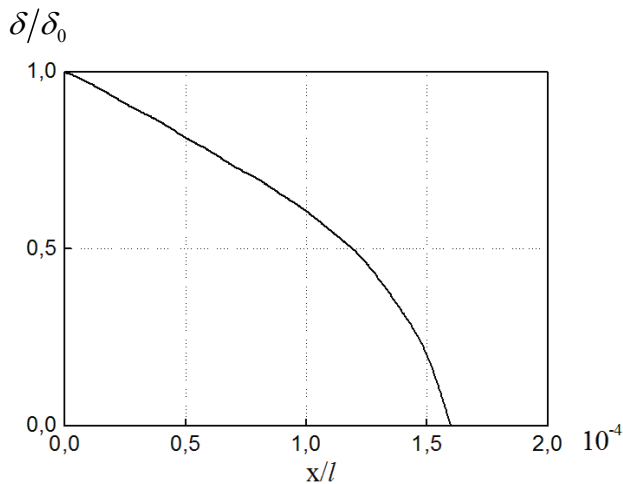

Fig. 8. Droplet evaporation in the vertical chamber at the direct flow: $\delta_0=10^{-7}$ m, $l=1$ m, $d_0=0.15$ kg/kg of dry air

Calculation results for condition (32) satisfied at the inlet are shown in Fig. 9. The process of mass transfer between particle and flow starts from condensation. The droplet size at initial moisture content $d_0=0.17$ kg/kg of dry air increases until the middle of chamber length and becomes equal to $4 \mu\text{m}$ (by the factor of 40), then it starts evaporating and at the distance of $0.7 l$ it disappears turning to vapor.

Therefore, condensation processes in irrigation chambers under some certain conditions can effect positively the efficiency of submicron particle capture, but these conditions can be achieved only on the basis of adequate mathematical models similar to the suggested one including model equations (Shilyaev et al., 2008) combined by mass and heat balance, heat and mass transfer equations of particles under the conditions of their absorption by fluid droplets at the motion along the chamber.

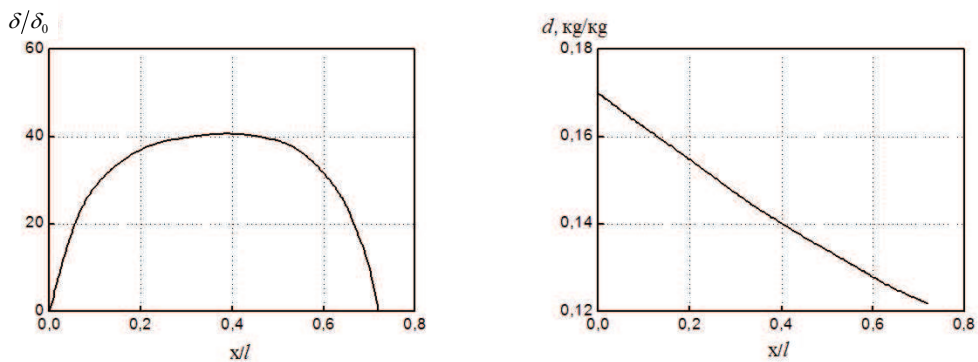

Fig. 9. Condensation is evaporation of a droplet in the vertical chamber at direct flow: $\delta_0=10^{-7}$ m, $l=1$ m, $d_0=0.17$ kg/kg of dry air

Let's determine the average velocity of vapor at its condensation on a droplet from balance relationship

$$\frac{\Delta m}{\Delta \tau} = \pi \bar{\delta}^2 \bar{w}_v \bar{\rho}_v = \frac{\pi}{6} (\delta_d^3 - \delta_0^3) \frac{\rho_f}{\Delta \tau}, \tag{40}$$

where Δm is droplet mass increase during time $\Delta \tau$ of its passing along distance l , for instance, the chamber length; \bar{w}_v is vapor velocity to the surface of condensation (droplet); $\bar{\rho}_v$ is the average vapor density on distance l near the droplet surface calculated by its temperature equal to the temperature of saturation; δ_0 and δ_d are initial and final diameters of droplet; ρ_f is droplet density; $\bar{\delta}$ is average size of a droplet on distance l . Time is $\Delta \tau = l / U$, where U is velocity of the vapor-gas flow along the chamber axis.

If we assume $\bar{\delta} = \sqrt{\delta_d \delta_0}$, from (40) we can obtain

$$\bar{w}_v \approx \frac{1}{6} \frac{\delta_d^2 U \rho_f}{\delta_0 l \bar{\rho}_v}. \tag{41}$$

In equation (41) we neglect summand δ_0^2 / δ_0 , since $\delta_0 \ll \delta_d$. It can be seen from (41) that velocity \bar{w}_v is reverse to the initial size of droplets. This regularity can be also obtained directly from the equation of droplet mass transfer:

$$\frac{dm}{d\tau} = \pi \delta^2 w_v \rho_v = \beta \pi \delta^2 (\rho_{1d} - \rho_1). \tag{42}$$

It follows from (42) that

$$w_v = \beta \frac{\rho_{1d} - \rho_1}{\rho_{1d}}, \tag{43}$$

but since we can assume for small droplets, as it was already mentioned, $\beta = 2 \frac{D}{\delta}$, it follows from equation (43) that $w_v \sim \frac{1}{\delta}$.

Let's estimate with the help of formula (41) condensation rates for Figs. 6 and 7:
at $l = 0.1\text{m}$

$$\delta_{d1}/\delta_{01} = 450, \delta_{01} = 10^{-1}\mu\text{m}, \delta_{d1} = 45\mu\text{m};$$

at $l = 1\text{m}$

$$\delta_{d2}/\delta_{02} = 4500, \delta_{02} = 10^{-2}\mu\text{m}, \delta_{d2} = 45\mu\text{m}.$$

Assuming in (41) that values of $U/\bar{\rho}_v$ differ slightly in these two considered cases, we obtain

$$\frac{\bar{w}_{v1}}{\bar{w}_{v2}} = \left(\frac{\delta_{d1}}{\delta_{d2}} \right)^2 \frac{\delta_{02}}{\delta_{01}}. \quad (44)$$

Along distance $l = 0,1\text{m}$ $\frac{\delta_{d1}}{\delta_{01}} = 1700, \delta_{02} = 10^{-2}\mu\text{m}, \delta_{d2} = 17\mu\text{m}; \frac{\delta_{d2}}{\delta_{02}} = 170, \delta_{01} = 10^{-1}\mu\text{m},$
 $\delta_{d1} = 17\mu\text{m}.$

As we can see, in two considered cross-sections of chamber two calculation versions give the same final size of droplets: in the first case it is $45\mu\text{m}$ and in the second it is $17\mu\text{m}$.

Thus, it follows from (44) in connection with $\delta_{d1} \approx \delta_{d2}$ that

$$\frac{\bar{w}_{v1}}{\bar{w}_{v2}} = \frac{\delta_{02}}{\delta_{01}}. \quad (45)$$

Relationship (45) proves the fact that the diffusion mechanism of small particle deposition on large droplets is insignificant because of small diffusion velocities of vapors at condensation on their surfaces, and it can be neglected; simultaneously it is very important for small droplets. This conclusion correlates with formula of B.V. Deryagin and S.S. Dukhin (Uzhov & Valdberg, 1972)

$$\eta_d = \frac{144\pi\mu D(\rho - \rho_v)}{g\rho_p^0\rho_{da}\delta_d(\delta_{d0}^2 - \delta_0^2)}. \quad (46)$$

Here μ is dynamic viscosity of vapor-gas flow, ρ_p^0 is density of particles, ρ_{da} is density of dry air in the vapor-gas mixture, and η_d is capture efficiency of particles with size δ_0 due to the diffusion effect.

According to calculations by formula (46), at $\delta_0 \ll \delta_d$ the efficiency of submicron dust deposition is low (Shilyaev et al., 2006).

5. Parametrical analysis of condensation capture of fine dust in Venturi scrubber

The Venturi scrubber (VS) is the most common type of wet dust collector for efficient gas cleaning from dust particles even of a micron size. Together with dust capture the absorption and thermal processes can occur in VS. The VS is used in various industries:

ferrous and non-ferrous metallurgy, chemistry and oil industry, production of building materials, power engineering, etc. The construction of VS includes combination of irrigated Venturi tube and separator (drop catcher). The Venturi tube has gradual inlet narrowing (converging cone) and gradual outlet extension (diffuser). A pinch in cross-section of Venturi tube is called a “throat”. The operation principle of VS is based on catching of dust particles, absorption or cooling of gases by droplets of irrigating fluid dispersed by the gas flow in Venturi tube. Usually the gas velocity in the throat of scrubber tube is 30-200 m/s, and specific irrigation is 0.1-6.0 l/s³. In the current section we are considering optimization of possible application of Venturi scrubber for fine dust capture under condensation conditions on the basis of the suggested physical-mathematical model.

Results of calculation on the basis of suggested model for VS are shown in Figs. 10 and 11. According to Fig. 10, at low moisture contents (almost dry air) with a rise of initial particle concentration the efficiency of their capture increases slightly and with an increase in moisture content it decreases (Fig. 10a). At that high efficiency of dust capture can be achieved at low particle concentrations and high moisture contents at the VS inlet (Fig. 10b). Dependence of dust capture efficiency on diffuser angle of Venturi tube α is shown in Fig. 11a, and it is obvious that for the given case the optimal is $\alpha \approx 7.7^\circ$. For any other case this optimal angle can be calculated by the model.

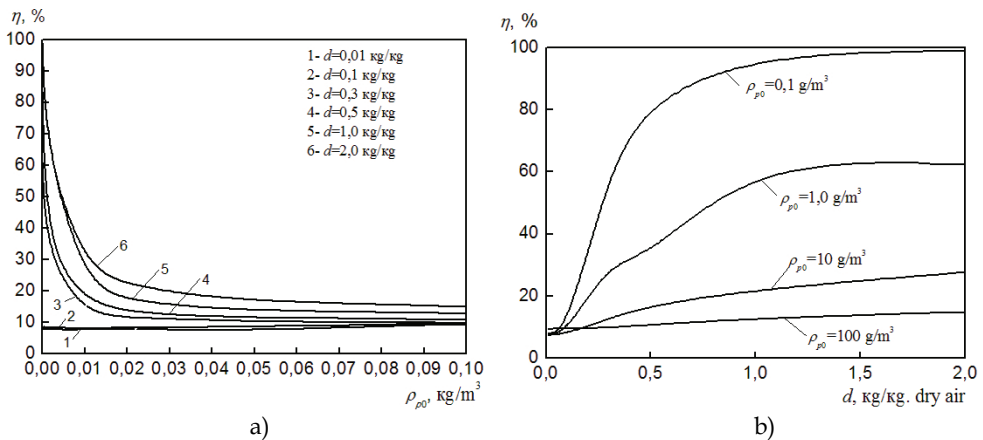

Fig. 10. Effect of initial particle concentration and moisture content on dust capture efficiency: $V_0=5$ m/s, $\Theta_0=293$ K, $\rho_p^0=10^3$ kg/m³, $q=0.5 \cdot 10^{-3}$ m³/m³, $U_0=160$ m/s, $T_{00}=333$ K, $a=6^\circ$, $l=1$ m, $\delta_0=10^{-7}$ m

Dust capture efficiency vs. relative diffuser length is shown in Fig. 11b, and it can be seen that the optimal length of diffuser tube, which provides the required dust capture efficiency, can be determined with the help of the model. Thus, for this case at required efficiency $\eta=99$ % the length of diffuser should be $l=1$ m.

According to Fig. 12, efficiency depends significantly on the flow velocity in the tube throat and irrigation coefficient. Calculations were carried out for diagram a) at following parameters: $l=1$ m, $V_{d0}=5$ m/s, $\delta=0.1$ μ m, $\Theta_0=293$ K, $a=6^\circ$, $\rho_{p0}=1$ g/m³, $\rho_p^0=10^3$ kg/m³, $q=2$ l/m³, $U_0=80$ m/s, $T_{00}=303$ K, $d_0=0.01193$ kg/kg of dry air.

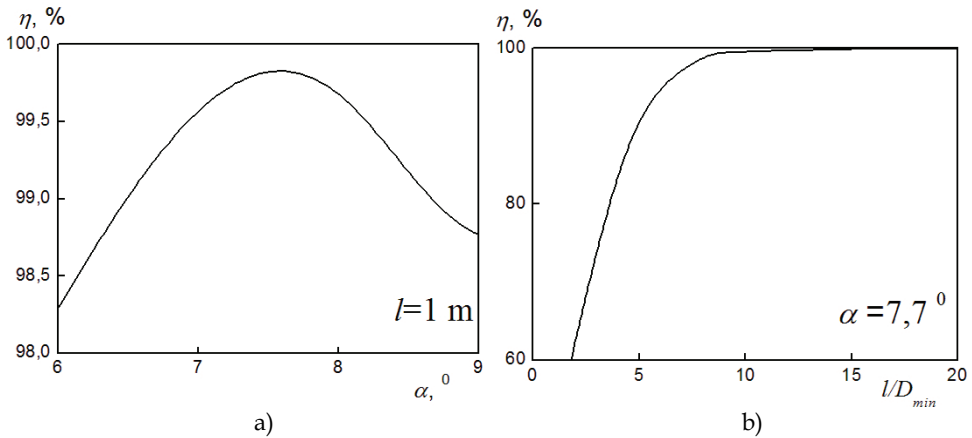

Fig. 11. The effect of diffuser angle (a) and diffuser length (b) on dust capture efficiency: $V_0=5$ m/s, $\Theta_0=293$ K, $\rho_p^0=10^3$ kg/m³, $q=10^{-3}$ m³/m³, $U_0= 80$ m/s, $T_{00}=333$ K, $\rho_{p0}=1$ g/m³, $d_0=0.5$ kg/kg of dry air, $\delta_0=10^{-6}$ m

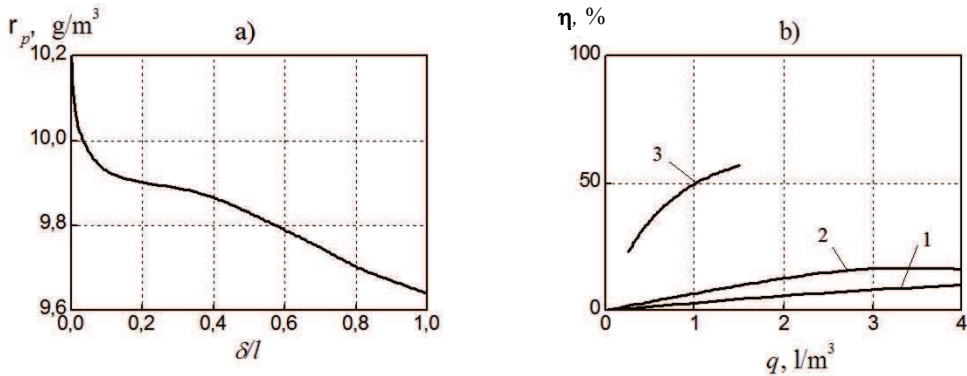

Fig. 12. Calculation results: a) distribution of particle concentration along the diffuser; b) efficiency of particle capture depending on irrigation coefficient: 1 - $U_0= 80$ m/s, $d_0=0.01193$ kg/kg of dry air; 2 - $U_0= 100$ m/s, $d_0=0.01193$ kg/kg of dry air; 3 - $U_0= 100$ m/s, $d_0=0.5$ kg/kg of dry air, other parameters are the same as for Fig. a)

6. Comparison of direct-flow and counter-flow apparatuses of condensation capture of fine dust

It is interesting to compare specific power inputs for gas cleaning from fine dust under the conditions of condensation of particle capture on fluid droplets in the direct-flow and counter-flow apparatuses as well as their sizes under the same conditions. For this purpose let's compare the counter-flow jet scrubber (CJS) and Venturi scrubber (VS) under the same flow rates of cracked gases cleaned from soot particles, corresponding to experimental data of (Uzhov & Valdberg, 1972) for CJS.

Comparative calculations were carried out for the following data. For CJS: $q=7.1 \cdot 10^{-3} \text{ m}^3/\text{m}^3$, $\delta_{d0}=700 \text{ }\mu\text{m}$, $V_{d0}=24.5 \text{ m/s}$, $\Theta_0=293 \text{ K}$, $T_{00}=443 \text{ K}$, $d_0=0.93 \text{ kg/kg}$ of dry air, $U_0=0.25 \text{ m/s}$, $\delta_0=0.12 \text{ }\mu\text{m}$, $\rho_{p0}=1.72 \text{ g/m}^3$, $D=3.0 \text{ m}$, $H=2; 3; 6; 9; 11; \text{ and } 12.5 \text{ m}$. For VS the diameter of tube throat D_{min} was determined from the equilibrium equation for volumetric flow rates of the vapor-gas flow at the inlets of the compared apparatuses. Thus, at $U_0=80 \text{ m/s}$ $D_{min}=0.17 \text{ m}$, at $U_0=160 \text{ m/s}$ $D_{min}=0.12 \text{ m}$. Angle α was varied as well as scrubber length l . Initial size of droplets δ_{d0} for VS was calculated by Nukiyama-Tanasava formula (39) depending on $(U_0 - V_{d0})$, fluid density ρ_f , q , coefficient of fluid surface tension σ_f (for water $\sigma_f=0.072 \text{ N/m}$); the value of initial velocity of droplets in tube throat V_{d0} was set 4.0 m/s . Calculation results are generalized in Figs. 13 and 14 for optimal angle $\alpha=7.7^\circ$, corresponding to maximal efficiency of dust capture. According to the figures, with an increase in the relative length of Venturi tube and relative height of CJS, the efficiency increases significantly, but the higher l/D_{min} and H/D , the less expressive is this growth. According to Fig. 13b, the efficiency growth is caused firstly by enlargement of "formations" (particles with condensate on their surface). Deceleration of efficiency growth depending on converging cone length and scrubber height is caused by a decrease in particle concentration in the flow and reduction in probability of collisions between "formations" and fluid droplets. The suggested model provides a possibility to determine the optimal length of Venturi tube l or scrubber height H for the required efficiency of dust capture.

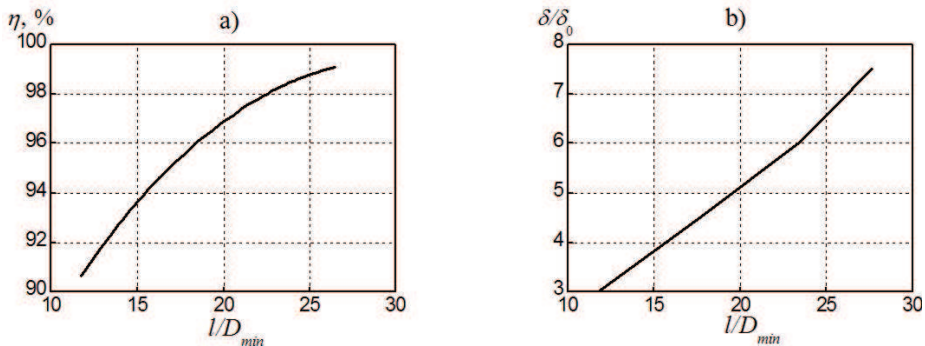

Fig. 13. Results of calculations by the model for Venturi scrubber: $q=7.1 \cdot 10^{-3} \text{ m}^3/\text{m}^3$, $V_{d0}=4.0 \text{ m/s}$, $\Theta_0=293 \text{ K}$, $T_{00}=443 \text{ K}$, $d_0=0.93 \text{ kg/kg}$ of dry air, $U_0=80 \text{ m/s}$, $\delta_0=1.2 \cdot 10^{-7} \text{ m}$, $\rho_{p0}=1.72 \text{ g/m}^3$, $D_{min}=0.17 \text{ m}$, $\alpha=7.7^\circ$

Calculation results on the relative size of "formations" and CJS efficiency under the same conditions as for VS, corresponding to experimental data for CJS on soot capture from cracked gases (Uzhov & Valdberg, 1972), are shown in Fig. 15 depending on the initial temperature of droplets. The height of experimental CJS was $H=12.7 \text{ m}$, and diameter was $D=3 \text{ m}$. It can be seen from the figure that with a decrease in droplet temperature at the inlet Θ_0 efficiency increases significantly. Thus, an increase in Θ_0 from 293 K ($20 \text{ }^\circ\text{C}$) to 278 K ($5 \text{ }^\circ\text{C}$) increases efficiency by 8% . This important result proves the fact that the same experimental efficiency $\eta \approx 90 \%$ can be obtained at significantly less height of the scrubber. Thus, according to calculations, at $\Theta_0=278 \text{ K}$ ($5 \text{ }^\circ\text{C}$) this value of efficiency can be achieved at height $H \approx 4-5 \text{ m}$ instead of 12.7 m , what reduces the dimensions and specific quantity of metal of the whole construction. The point in Fig. 15b indicates the experimental value of efficiency, and this means that model operability is proved well by the experiment.

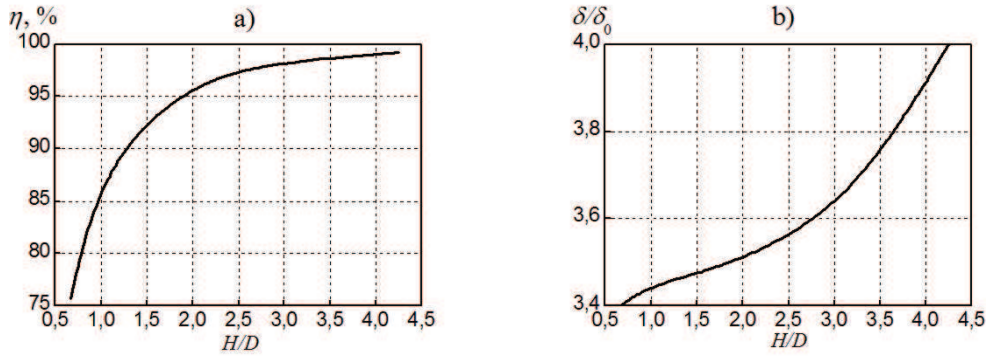

Fig. 14. Results of calculations for CJS: $q=7.1 \cdot 10^{-3} \text{ m}^3/\text{m}^3$, $\delta_{d0}=7 \cdot 10^{-4} \text{ m}$, $V_{d0}=24.5 \text{ m/s}$, $\Theta_0=293 \text{ K}$, $T_{00}=443 \text{ K}$, $d_0=0.93 \text{ kg/kg}$ of dry air, $U_0=0.25 \text{ m/s}$, $\delta_0=1.2 \cdot 10^{-7} \text{ m}$, $\rho_{p0}=1.72 \text{ g/m}^3$, $D=3.0 \text{ m}$

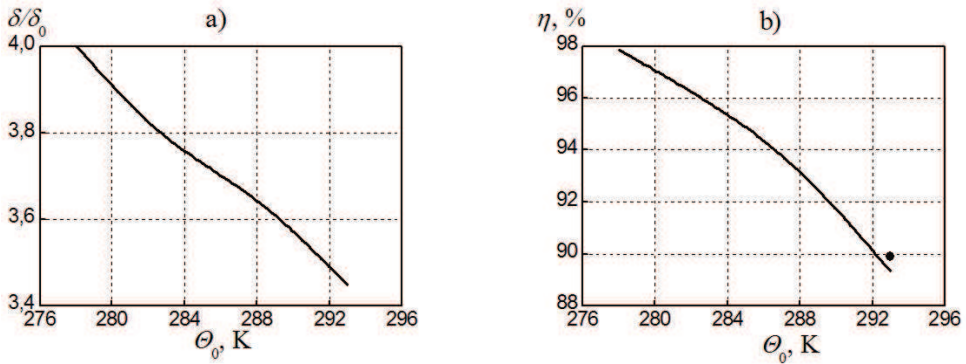

Fig. 15. Results of calculations by the model for CJS: $H=12.75 \text{ m}$, $q=7.1 \cdot 10^{-3} \text{ m}^3/\text{m}^3$, $\delta_{d0}=7 \cdot 10^{-4} \text{ m}$, $V_{d0}=24.5 \text{ m/s}$, $T_{00}=443 \text{ K}$, $d_0=0.93 \text{ kg/kg}$ of dry air, $U_0=0.25 \text{ m/s}$, $\delta_0=10^{-7} \text{ m}$, $\rho_{p0}=1.72 \text{ g/m}^3$.

According to analysis, for similar required efficiency, the direct-flow dust catchers (in this case they are VS), despite their advantage by dimensions over the counter-flow apparatuses, require higher power inputs for gas cleaning, determined by pressure drops in apparatuses. Actually, for VS the coefficient of hydraulic resistance can be estimated by formula (Shilyaev et al., 2006)

$$\xi_{i.v} = \xi_{d.i} \left(1 + 0,63q^{0,7} \frac{\rho_f}{\rho} \right), \tag{47}$$

where $\xi_{d.i}$ is resistance coefficient of the dry Venturi tube, it is assumed to be 0.12-0.15, ρ is gas density. Under our conditions for estimate calculation we assume $q=7.1 \cdot 10^{-3} \text{ m}^3/\text{m}^3$, $\rho_f=10^3 \text{ kg/m}^3$, $\xi_{d.i}=0.12$, $\rho \approx \rho_0 \frac{273}{T_m}$, $T_m=397.6 \text{ K}$, where $T_m=0.5(T_{00}+T_{out})$, $T_{00}=443 \text{ K}$, $T_{out}=352.2 \text{ K}$, and $\rho_0(273 \text{ K})=0.51 \text{ kg/m}^3$ (Uzhov & Valdberg, 1972). Then, $\rho=0.35 \text{ kg/m}^3$.

Substituting these data into (47), we obtain $\xi_{t,v} = 6,9$. Hence, at $U_0=80$ m/s the pressure drop on the Venturi tube is $\Delta P_{t,v} = \xi_{t,v} \rho \frac{U_0^2}{2} = 7728$ Pa, and at $U_0=160$ m/s $\Delta P_{t,v} = 30912$ Pa.

This resistance exceeds the resistance of CJS, where the main part of energy is spent for fluid spraying, and hydraulic resistance is low (as usual, the velocity of cleaned gas does not exceed 1 m/s). At that, the same energy is spent for fluid spraying in Venturi tube. Thus, specific energy spent for fluid spraying is

$$\Delta P_f = qP_f,$$

where P_f is pressure of fluid fed to the spraying jets, equal to 300-400 kPa. Thus, in our case we obtain

$$\Delta P_f = 7,1 \cdot 10^{-3} (300 - 400) 10^3 = (2130 - 2840) \text{ J/m}^3.$$

Moreover, to estimate the total dimensions of VS, the sizes of droplet catcher should be added to the sizes of Venturi tube and power inputs for overcoming of hydraulic resistance should be taken into account.

All the above mentioned proves the fact that the counter-flow schemes of condensation dust capture are in preference to the direct-flow ones.

7. Conclusion

Therefore, the physical-mathematical model of heat and mass transfer and condensation capture of fine dust in scrubbers was formulated, and its efficiency was determined. The suggested model can be used for preliminary calculations and estimation of the most rational determining parameters of apparatuses, which provide efficient gas cleaning.

8. References

- Amelin, A.G. (1966). *Theoretical Foundations of Fog Formation at Vapor Condensation*. – Moscow: Khimiya.
- Pazhi, D.G., Galustov, V.S. (1984). *Foundations of Liquids Spraying Technology*. – Moscow: Khimiya.
- Shilyaev, M.I., Khromova, E.M. (2008). Simulation of heat and mass transfer in spray chambers. *Theoretical Foundations of Chemical Engineering*, Vol. 42, No. 4, P. 404-414.
- Shilyaev, M.I., Khromova, E.M., Tumashova, A.V. (2008). Physical-mathematical model of heat and mass transfer process in jet irrigation chambers at high moisture contents. *Izv. Vuziv. Stroitelstvo*, No. 6, P. 75-81.
- Shilyaev, M.I., Shilyaev, A.M., Grischenko, E.P. (2006). *Calculation Methods for Dust Catchers*. – Tomsk: Tomsk State University of Architecture and Building.
- Shilyaev, M.I., Shilyaev, A.M., Khromova, E.M., Doroshenko, Yu.N. (2008). About condensation mechanisms of dust capture intensification in CJS and DC. *Izv. Vuzov. Stroitelstvo*, No.4, P. 61-67.
- Shvydkiy, V.S., Ladygichev, M.G. (2002). *Gas Cleaning: Reference Book*. – Moscow: Teploenergetik.
- Uzhov, V.N., Valdberg, A.Yu. (1972). *Gas Cleaning by Wet Filters*. – Moscow: Khimiya.

- Valdberg, A.Yu., Savitskaya, N.M. (1993). Calculation of dust capture at condensation operation of scrubbers. *Theoretical Foundations of Chemical Engineering*, Vol. 27, No. 5, P. 526-530.
- Vitman, L.A., Katsnelson, B.D., Paleev, I.I. (1962). *Liquid Spraying by Jets*. – Moscow-Leningrad: Gosenergoizdat.

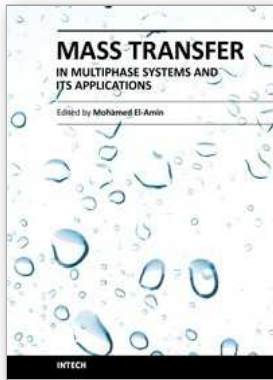

Mass Transfer in Multiphase Systems and its Applications

Edited by Prof. Mohamed El-Amin

ISBN 978-953-307-215-9

Hard cover, 780 pages

Publisher InTech

Published online 11, February, 2011

Published in print edition February, 2011

This book covers a number of developing topics in mass transfer processes in multiphase systems for a variety of applications. The book effectively blends theoretical, numerical, modeling and experimental aspects of mass transfer in multiphase systems that are usually encountered in many research areas such as chemical, reactor, environmental and petroleum engineering. From biological and chemical reactors to paper and wood industry and all the way to thin film, the 31 chapters of this book serve as an important reference for any researcher or engineer working in the field of mass transfer and related topics.

How to reference

In order to correctly reference this scholarly work, feel free to copy and paste the following:

M.I. Shilyaev and E.M. Khromova (2011). Condensation Capture of Fine Dust in Jet Scrubbers, Mass Transfer in Multiphase Systems and its Applications, Prof. Mohamed El-Amin (Ed.), ISBN: 978-953-307-215-9, InTech, Available from: <http://www.intechopen.com/books/mass-transfer-in-multiphase-systems-and-its-applications/condensation-capture-of-fine-dust-in-jet-scrubbers>

INTECH
open science | open minds

InTech Europe

University Campus STeP Ri
Slavka Krautzeka 83/A
51000 Rijeka, Croatia
Phone: +385 (51) 770 447
Fax: +385 (51) 686 166
www.intechopen.com

InTech China

Unit 405, Office Block, Hotel Equatorial Shanghai
No.65, Yan An Road (West), Shanghai, 200040, China
中国上海市延安西路65号上海国际贵都大饭店办公楼405单元
Phone: +86-21-62489820
Fax: +86-21-62489821

© 2011 The Author(s). Licensee IntechOpen. This chapter is distributed under the terms of the [Creative Commons Attribution-NonCommercial-ShareAlike-3.0 License](#), which permits use, distribution and reproduction for non-commercial purposes, provided the original is properly cited and derivative works building on this content are distributed under the same license.