

Hybrid Solar Vehicles

Gianfranco Rizzo, Ivan Arsie and Marco Sorrentino
*Department of Mechanical Engineering, University of Salerno
 Italy*

1. Introduction

In the last years, increasing attention is being spent towards the applications of solar energy to electric and also to hybrid cars. But, while cars only fed by sun do not represent a practical alternative to cars for normal use, the concept of a hybrid electric car assisted by solar panels appears more realistic (Letendre et al., 2003; Fisher, 2009). The reasons for studying and developing a Hybrid Solar Vehicle can be summarized as follows:

- fossil fuels, largely used for car propulsion, are doomed to depletion; their price tends to increase, and is subject to large and unpredictable fluctuations;
- the CO₂ generated by the combustion processes occurring in conventional thermal engines contributes to the greenhouse effects, with dangerous and maybe dramatic effects on global warming and climatic changes;
- the worldwide demand for personal mobility is rapidly growing, especially in China and India; as a consequence, energy consumption and CO₂ emissions related to cars and transportation are increasing;
- solar energy is renewable, free and largely diffused, and Photovoltaic Panels are subject to continuous technological advances in terms of cell efficiency; their diffusion is rapidly growing, while their cost, after a continuous decrease and an inversion of the trend occurred in 2004, is continuing to decrease (Fig. 1);

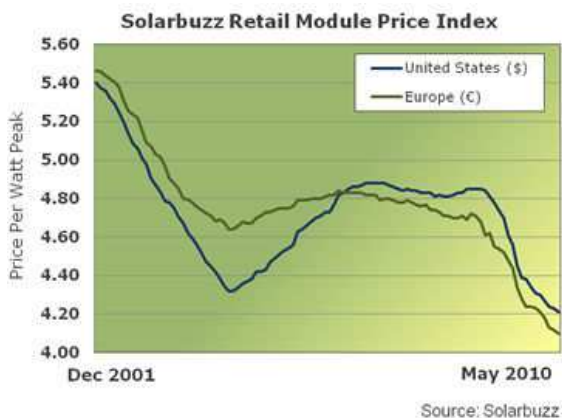

Fig. 1. Trends for cost of photovoltaic modules.

- solar cars, powered only by the sun, in spite of some spectacular outcomes in competitions as World Solar Challenge, do not represent a practical alternative to conventional cars, due to limitations on maximum power, range, dimensions and costs;
- Hybrid Electric Vehicles (HEV) have evolved to industrial maturity, and represent now a realistic solution to important issues, such as the reduction of gaseous pollution in urban drive as well as the energy saving requirements (Guzzella and Amstutz, 1999); the degree of electrification of the fleet is expected to grow significantly in next years (Fisher 2009, Fig. 2).

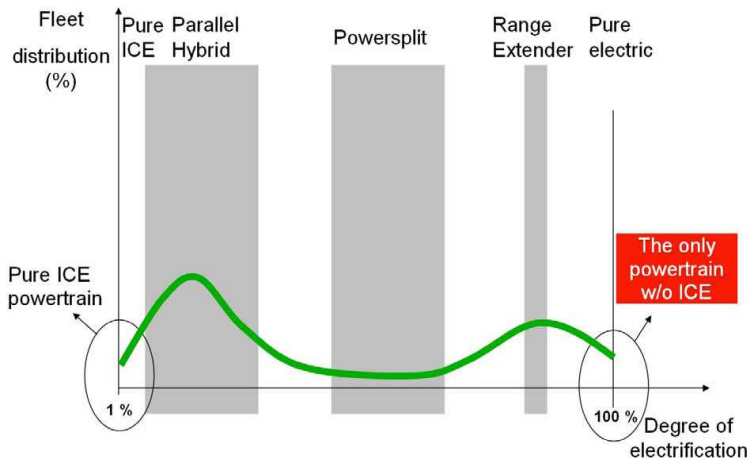

Fig. 2. Degree of electrification. Vision 2025 (Fisher, 2009).

Despite their potential interest, Hybrid Solar Vehicles (HSV) have received relatively little attention in the open literature until a few years ago, particularly if compared with the great effort spent in the last years on other solutions, as fuel cell vehicles, which strongly suffer from the critical issues related to the production and distribution of hydrogen. The scepticism about the direct use of solar energy in cars may be explained by the misleading habit to analyze the automotive systems in terms of power, instead of energy, as discussed in next paragraphs. A proper design of the vehicle-powertrain system may allow meeting a significant share of the total energy required with the energy captured by the panels, during both driving and parking phases, as shown in next paragraphs and evidenced in previous papers (Arsie et al., 2006, 2007). Their economic feasibility appears encouraging: according to some recent studies (Neil C., 2006), PV panels added to hybrid cars could be even more cost effective than PV panels added to buildings. This result has been also confirmed by some recent evaluations, aimed to the estimation of pay-back time of moving and fixed solar roofs for a PV assisted vehicle at different latitudes (Coraggio et al., 2010 II).

Moreover, the presence of a photovoltaic panel on a Plug-In Hybrid Electric Vehicle (PHEV) can enhance the development of Vehicle to Grid (V2G) technology: in this approach, the plug-in vehicles, besides receiving power when parked, can also provide power to the grid. Use of PHEV for V2G can provide benefits to both vehicle owner and the power utility company, apart from the reduced tailpipe emissions and increased mileage, particularly when the number of vehicle connected to the grid is large (Kempton et al., 2001). This technology is now spreading: on September 2009, Delaware's Governor signed a law on

V2G, requiring electric utilities to compensate owners of electric cars for electricity sent back to the grid at the same rate they pay for electricity to charge the battery (www.udel.edu/V2G/). In this context, it is clear that a solar powered vehicles can contribute to power the grid also using solar energy, that is free and renewable. This opportunity prevents also to waste solar energy provided by PV panels on the car when car batteries are fully charged.

In principle, Hybrid Solar Vehicles (HSV) could therefore sum up the advantages of HEV and solar power, by the integration of Photovoltaic Panels in a Hybrid Electric Vehicle. But it would be simplistic to consider the development of a HSV as a straightforward addition of photovoltaic panels to an existing Hybrid Electric Vehicle, that could be considered just as a first step. In fact, the development of HEV's, despite it was based on well-established technologies, showed how considerable research efforts were required for both optimizing the power-train design and defining the most suitable control and energy-management strategies. Analogously, to maximize the benefits coming from the integration of photovoltaic with HEV technology, it is required performing accurate re-design and optimization of the whole vehicle-powertrain system. In these vehicles, in fact, there are many mutual interactions between energy flows, propulsion system component sizing, vehicle dimension, performance, weight and costs, whose connections are much more critical than in conventional and also in hybrid cars (Arsie et al., 2006).



Fig. 3. Astrolab, a Hybrid Solar Vehicle developed by the French company Venturi.

Particularly, the presence of solar panels requires to study and develop specific solutions, since instead of the usual "charge sustaining" strategies adopted in HEV, proper "charge depletion" strategies have to be adopted, to account for the battery recharging during parking (Arsie et al., 2007, 2008). Moreover, advanced look-ahead capabilities are required for such vehicles. In fact, at the end of driving the final state of charge (SOC) is required to be low enough to allow full storage of solar energy captured in the next parking phase, whereas the adoption of an unnecessary constantly-low value of final SOC would give additional energy losses and compromise battery lifetime. The optimal management of battery would therefore require a previous knowledge of the solar energy to be captured in next parking phase, that can be achieved through the real-time access to weather forecast (Coraggio et al., 2010, 1).

The impact of solar panels contribution can be significantly improved by adopting suitable Maximum Power Point Tracking (MPPT) techniques, which role is more critical than in fixed plants. The recourse to an automatic sun-tracking roof to maximize captured energy in parking phases has also been studied (Coraggio et al., 2010, II).

Moreover, as it happens for other hybrid vehicles working in start-stop operation, the optimal power split between the internal combustion engine and battery pack must be pursued also taking into account the effect of engine thermal transients. Previous studies conducted by the research group on series hybrid solar vehicles demonstrated that the combined effects of engine, generator and battery losses, along with cranking energy and thermal transients, produce non trivial solutions for the engine/generator group, which should not necessarily operate at its maximum efficiency. The strategy has been assessed via optimization done with Genetic Algorithms, and implemented in a real-time rule-based control strategy (Arsie et al., 2008, 2009, 2010).

In the following, all these topics will be discussed, with reference to the computational and experimental results presented in published papers and achieved during the on-going research.

2. Automotive applications of solar energy

2.1 Photovoltaic panels: efficiency and cost

The conversion from light into direct current electricity is based on the researches performed at the Bell Laboratories in the 50's, where the principle discovered by the French physicist Alexandre-Edmond Becquerel (1820-1891) was applied for the first time. The photovoltaic panels, working thanks to the semiconductive properties of silicon and other materials, were first used for space applications. The diffusion of this technology has been growing exponentially in recent years (Fig. 4), due to the pressing need for a renewable and carbon-free energy (REN21, 2009).

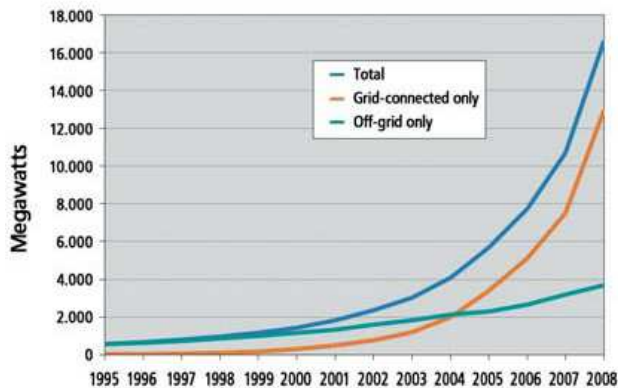

Fig. 4. Solar PV, world capacity 1995-2008

The amount of solar energy is impressive: the 89 petawatts of sunlight reaching the Earth's surface is almost 6,000 times more than the 15 terawatts of average electrical power consumed by humans (Smil, 2006). A pictorial view of the potentialities of photovoltaics is given in Fig. 5, where the areas defined by the dark disks could provide more than the

world's total primary energy demand (assuming a conversion efficiency of 8%). The applications range from power station, satellites, rural electrification, buildings to solar roadways and, of course, transport.

In Fig. 6 the trends for the efficiency of photovoltaic cells are shown. Most of the today PV panels, with multicrystalline silicon technology, have efficiencies between 11% and 18%, while the use of mono-crystalline silicon allows to increase the conversion efficiency of about 4%. The recourse to multi-junction cells, with use of materials as Gallium Arsenide (Thilagam et al, 1998), and to concentrating technologies (Segal et al., 2004), has allowed to reach 40% of cell efficiency. Anyway, the cost of these latter solutions is still too high for a mass application on cars.

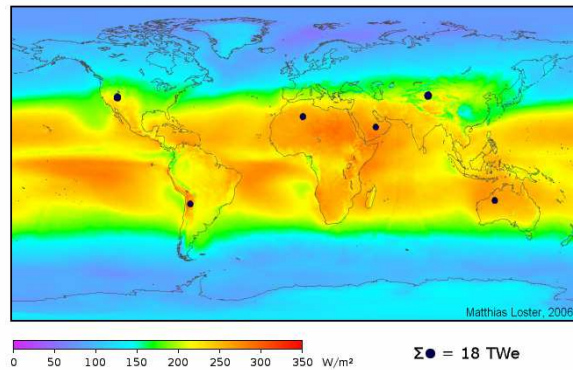

Fig. 5. Average solar irradiance (W/m²) for a horizontal surface (Wikipedia).

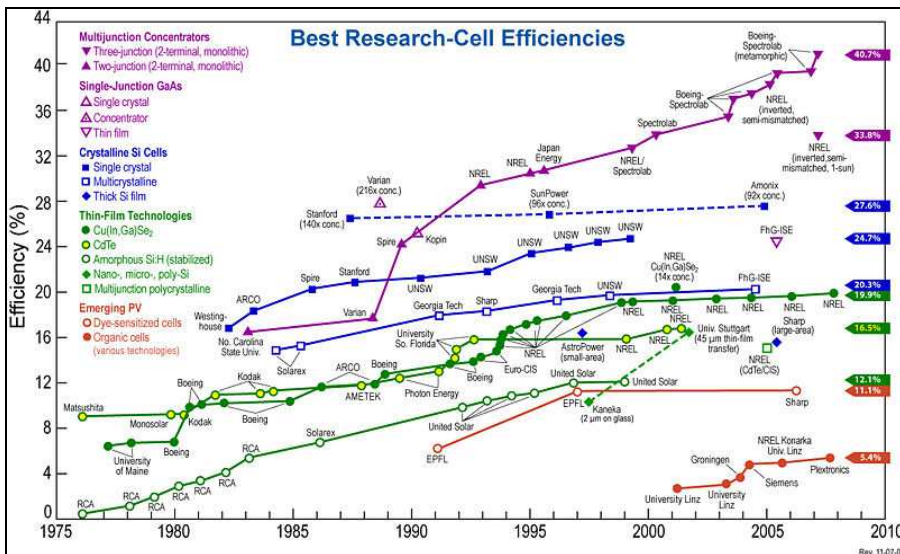

Fig. 6. Trends for efficiency of photovoltaic cells.

About price of solar modules, the market has experienced a long period of falling down of the prices since January 2002 up to May 2004. Afterwards, prices began rising again, until 2006-2007. This inversion has been attributed to the outstripping of global demand with respect to the supply, so that the manufacturers of the silicon needed for photovoltaic production cannot provide enough raw materials to fill the needs of manufacturing plants capable of increased production (Arsie et al., 2006; see also www.backwoodsolar.com). After 2008, the prices began to fall down again, both in USA and in Europe (Fig. 1).

2.2 Solar energy for cars: pros and cons

The potential advantages of solar energy are clear: it is free, abundant and rather evenly distributed (Fig. 5), more than other energy sources as fossil fuels, uranium, wind and hydro. It has been considered that the solar energy incident on USA in one single day is equivalent to energy consumption of such country for one and half year, and this figure could reach embarrassingly high values in most developing countries.

At the same time, also the limitations of such energy source seem clear: it is intermittent, due to the effects of relative motion between Earth and Sun, and variable in time, due to weather conditions (while the former effect can be predicted precisely, the latter can be foreseen only partially and for short term). But the most serious limitation for direct automotive use concerns its energy density: the amount of radiation theoretically incident on Earth surface is about 1360 W/m^2 (Quaschnig, 2003) and only a fraction of this energy can be converted as electrical energy to be used for propulsion. Considering that the space available for PV panels on a normal car is limited (from about 1 m^2 in case of panels outfitting 'normal' cars to about 6 m^2 for some solar cars), it emerges that the net power achievable by a solar panel is about two order of magnitude less than the power of most of today cars.

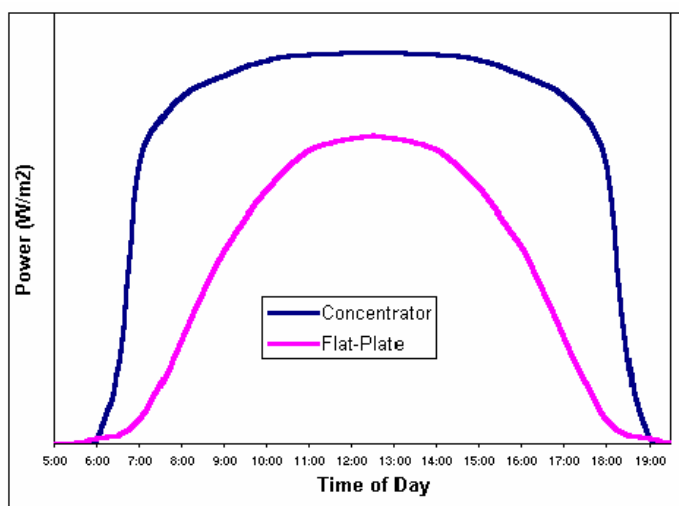

Fig. 7. Solar panel power during a day, for different technologies.

But this simple observation, that explains the scepticism about solar energy in most of the automotive community, is based on the misleading habit to think in terms of power, instead

of energy. In fact, for a typical use in urban driving (no more than one hour per day, according to recent Statistics for Road Transport, with an average power between 7 and 10 kW, considering a partial recovery of braking energy), the net energy required for traction can be about 8 kWh per day. On the other hand, a PV panel of 300 W of peak power can operate not far from its maximum power for many hours, especially if advanced tracking techniques would be adopted (Fig. 7). In these conditions, the solar contribution can represent a rather significant fraction, up to 20-30%, of the required energy (Table 1).

	Maximum Power (kW)	Average Power (kW)	Time (h/day)	Energy (kwh/day)
A - Car	70	8	1	8
B - PV	0.30	0.2	10	2
B/A %	0.4 %	2.5 %	1000 %	25 %

Table 1. Incidence of solar contribution in terms of power and energy

It therefore emerges that benefits of solar energy can be maximized when cars are used mostly in urban environment and in intermittent way, spending most of their time parked outdoor, and of course in countries where there is a “sufficient” solar radiation. But, as it will be shown in next sections, feasible locations are not necessarily limited to “tropical” countries.

3. Research issues related to hybrid solar vehicles

There are several research issues related to the application of PV panels on cars. PV panels can be added to a car just to power some accessories, as ventilation or air conditioner, as in Toyota Prius Solar (Fig. 8), or to contribute to car propulsion. Particularly in this latter case, it would be simplistic to consider their integration as the sole addition of photovoltaic panels to an existing vehicle. In fact, the development of HEV's, despite it was based on well-established technologies, has shown how considerable research efforts were required



Fig. 8. Toyota Prius Solar

for both optimizing the power-train design and defining the most suitable control and energy-management strategies. Analogously, to maximize the benefits coming from the integration of photovoltaic with HEV technology, it is required performing accurate redesign and optimization of the whole vehicle-powertrain system, considering the interactions between energy flows, propulsion system component sizing, vehicle dimension, performance, weight and costs. In the following, some of these aspects are described, also based on the author's direct experience on Hybrid Solar Vehicles.

3.1 Solar panel control

The surface of solar panels on a car is limited, with respect to most stationary applications. It is therefore important to maximize their power extraction, by analyzing and solving the problems that could reduce their efficiency. Part of these aspects are common to the stationary plants also, but some of them are quite specific of automotive applications. For example, the need of connecting cells of different types (technology as well as electrical and manufacturing characteristics) within the same array usually leads to mismatching conditions. This may be the case of using standard photovoltaic cells for the roof and transparent ones, in place of glasses, connected in series. Again, even small differences among the angles of incidence of the solar radiation concerning different cells/panels that compose the panel/string may cause a mismatching effect that greatly affects the resulting photovoltaic generator overall efficiency. Such reduction may become more significant at high cell temperatures, with a de-rating of about $0.5\%/^{\circ}\text{C}$ for crystalline cells and about $0.2\%/^{\circ}\text{C}$ for amorphous silicon cells (Gregg, 2005).

These effects are more likely in a car, due to the exigency to cover a curved surface, where differences in solar radiation and temperature can be higher than in a stationary plant. All these aspects are of course enhanced and complicated during driving, due to orientation changes and shadows. In the photovoltaic plants it is mandatory to match the PV source with the load/battery/grid in order to draw the maximum power at the current solar irradiance level.

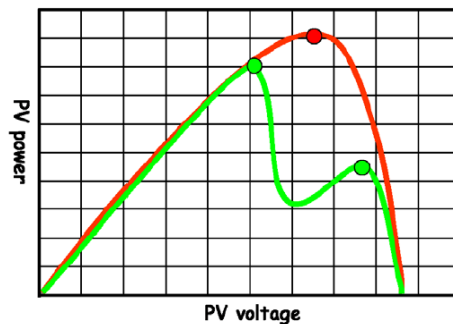

Fig. 9. Power vs. voltage characteristic of a PV field under uniform conditions (red) and with mismatching (green).

To this regard, a switching dc-dc converter controlled by means of a Maximum Power Point Tracking (MPPT) strategy is used (Hohm, 2000) to ensure the source-load matching by properly changing the operating voltage at the PV array terminals in function of the actual conditions. Usually, MPPT strategies derived by the basic Perturb and Observe (P&O)

approach are able to detect the unique peak of the power vs. voltage characteristic of the PV array, in presence of uniform irradiance (Fig. 9, red curve). But, due to mismatching and non uniform irradiation, temperature distribution and manufacturing features, the shape of the PV characteristic may exhibit more than one peak (Fig. 9, green curve). In these cases, the standard MTPP techniques tend to fail, so causing a reduction in power extraction (Egiziano et al., 2007; Femia et al., 2008). More advanced approaches, based on a detailed modelling of the PV field and on numerical techniques, have been developed to face with this problem (Jain, 2006; Liu, 2002).

3.2 Power electronics issues

In a solar assisted electric or hybrid vehicle, particular attention must be spent on power electronics, to enable better utilization of energy sources. To this purpose, high efficiency converter topologies, with different system configurations and particular control algorithms, are needed (Kassakian, 2000; Cacciato et al., 2004).

The use of multi-converters configurations could be advisable to solve the problems of solar generators such as PV modules mismatching and partial shadowing. A comparative study of three different configurations for a hybrid solar vehicle has been recently presented (Arsie et al., 2006, Cacciato et al., 2007). In order to reduce power devices losses, the increase of converter switching frequencies by adoption of soft-switching topologies is also considered. The advantages consist in reducing the size of the passive components and, consequently, the converter weight and volume while decrease the overall Electro Magnetic Interference (EMI), a critical point in automotive applications. Moreover, the converters can be designed by adopting recent technologies such as planar magnetic structures and SMD components, in order to allow the converters to be located inside the photovoltaic modules.

3.3 Optimal design of hybrid solar vehicles

A study on the optimal design of a Hybrid Solar Vehicle has been performed at the University of Salerno, considering performance, fuel consumption, weight and costs of the components (Arsie et al., 2007, 2008). The study, that has determined optimal vehicle dimensions and powertrain sizing for various scenarios, has shown that economic feasibility (pay-back between 2 and 3 years) could be achieved in a medium term scenario, with mild assumptions in terms of fuel price increase, PV efficiency improvement and PV cost reduction.

A prototype of HSV with series structure (Fig. 10) has also been developed (Adinolfi et al., 2008), within the framework on an educational project funded by EU (Leonardo project I05/B/P/PP-154181 "Energy Conversion Systems and Their Environmental Impact, www.dimec.unisa.it/Leonardo). The specifications of the prototype are presented in Table 2.

Vehicle lay-out is organized according to a series hybrid architecture, as shown on Fig. 11. With this approach, the photovoltaic panels PV assist the Electric Generator EG, powered by an Internal Combustion Engine (ICE), in recharging the Battery pack (B) in both parking mode and driving conditions, through the Electric Node (EN). The Electric Motor (EM) can either provide the mechanical power for the propulsion or restore part of the braking power during regenerative braking. In this structure, the thermal engine can work mostly at constant power, corresponding to its optimal efficiency, while the electric motor EM is designed to assure the attainment of the vehicle peak power.



Fig. 10. A prototype of Hybrid Solar Vehicle with series structure developed at the University of Salerno.

<p>Vehicle Piaggio Porter Length 3.370 m Width 1.395 m Height 1.870 m Drive ratio 1:4.875</p>	<p>Photovoltaic Panels Polycrystalline Surface APV 1.44 m² Weight 60 kg Efficiency 0.125</p>
<p>Electric Motor BRUSA MV 200 – 84 V Continuous Power 9 KW Peak Power 15 KW</p>	<p>Electric Generator Yanmar S 6000 Power COP/LTP 5.67/6.92 kVA Weight 120 kg</p>
<p>Batteries 16 6V Modules Pb-Gel Mass 520 Kg Capacity 180 Ah</p>	<p>Overall weight (w driver) MHSV 1950 kg</p>

Table 2. Specifications of the HSV prototype

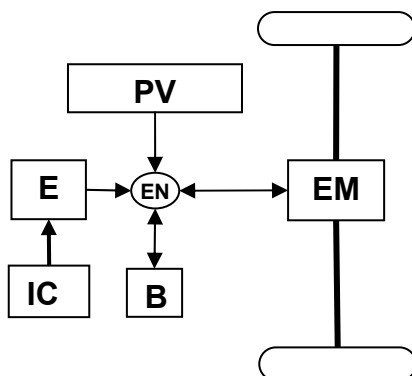

Fig. 11. Scheme of a series Hybrid Solar Vehicle

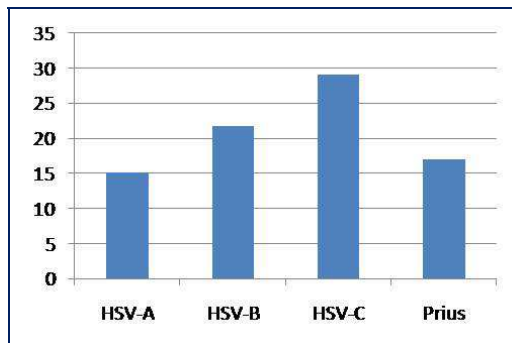

Fig. 12. Fuel Economy (km/l) on ECE Cycle - HSV vs. Toyota Prius. A - actual prototype. B - PV eff.=18% - Batt.=75 Ah. C - B+ 20% weight off - Lithium-Ion Batt.

Experimental and numerical activities have been conducted to develop and validate a comprehensive HSV model (Adinolfi et al., 2008). The model accounts for vehicle longitudinal dynamics along with the accurate evaluation of energy conversion efficiency for each powertrain component. While the actual prototype (HSV-A, Fig. 12) is penalized by a non optimal choice of their components, also due to budget limitations, the simulation model validated over the prototype data shows that very interesting values of fuel economy could be reached by improving the efficiency of solar panels (from 12% to 18%) and optimizing battery capacity and weight (HSV-B), and further reducing vehicle weight by adoption of Lithium-Ion batteries instead of original Lead-Acid (HSV-C).

3.4 Management and control of energy flows

The energy management of Hybrid Solar Vehicles, in spite of many similarities with HEV's, could not simply borrowed from the solutions developed for HEV's: in fact, while in these latter a charge sustaining strategy is usually adopted, in HSV's the battery can be recharged also during parking time by solar energy, and therefore a charge depletion strategy has to be followed during driving, as it happens for Plug-In Hybrid Electric Vehicles (PHEV) (Marano et al., 2009). Anyway, there are again some differences between PHEV and HSV: while for PHEV the recharge is mainly finalized to extend the vehicle range, for HSV's the input energy is free, and solar recharge should be maximized not only to extend the range, but mainly to minimize fuel consumption and CO₂ emissions. Therefore, at the end of driving cycle the final state of charge (SOC) should be sufficiently low to leave room for the solar energy to be stored in the battery in the next parking phase. On the other hand, the adoption of an unnecessary low value of final SOC could produce additional energy losses associated to battery operation, so increasing fuel consumption.

In a recent paper (Rizzo & Sorrentino, 2010), the effects of different strategies of selection of final SOC are studied by simulation over hourly solar data at different months and locations, and the benefits achievable by estimating the energy expected in next parking phase are assessed. The simulations are carried out with a dynamic model of a HSV previously developed (Arsie et al., 2007), including a rule-based (RB) energy management strategy. The results have shown that the estimation of the incoming solar energy in next parking phase produces a more efficient energy management, with reduction in fuel consumption, particularly at higher insolation (Fig. 13).

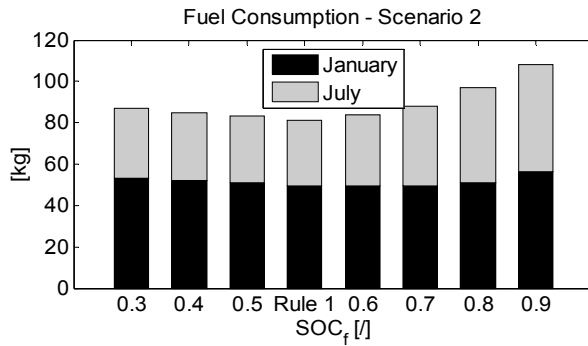

Fig. 13. Effects of optimized (Rule 1) and parametric choice of SOC on Fuel Consumption for a Hybrid Solar Vehicles (Los Angeles, January and July, 1988). $\eta_{PV} = 0.19$

The RB control architecture consists of two loops: i) an external loop, defining the desired final state of charge to be reached at the end of the driving cycle; ii) an internal loop, estimating the average power delivered by the internal combustion engine and SOC deviation. The scheme of rule-based control strategy operation is shown in Fig. 14.

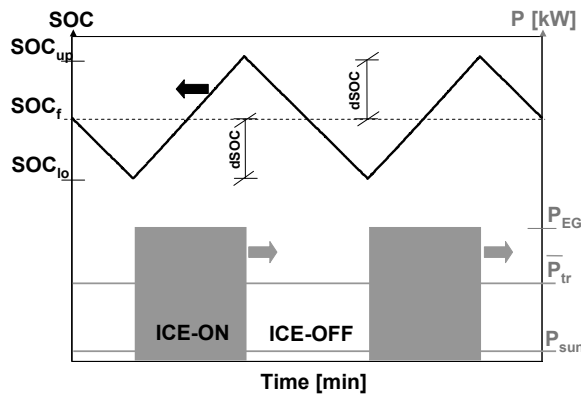

Fig. 14. Schematic representation of the rule-based control strategy for quasi-optimal energy management of a series HSV powertrain.

The results of RB strategy have been successfully compared with a benchmark (non implementable) strategy, obtained by means of a Genetic Algorithm (Sorrentino et al., 2009). In the study, a vehicle dynamic model considering also the effects of engine thermal transients on fuel consumption and power, related to start-stop operation (Fig. 15), has been adopted.

Fig. 16 compares the optimal power of the engine-generator group, operating in start-stop mode, at various vehicle average power (Rizzo et al., 2010). The red line indicates the most efficient ICE-EG operating point (PEG,opt), corresponding to about half nominal power. Such comparison indicates that at high road loads the optimal power values exhibit a load following behavior, whereas at low power demand they always undergoes PEG,opt. These results show that, due to the combined effects of engine losses, of thermal transients and of

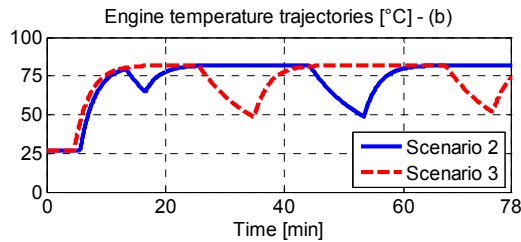

Fig. 15. Simulated engine temperature profiles in a series hybrid electric vehicle with start-stop operation.

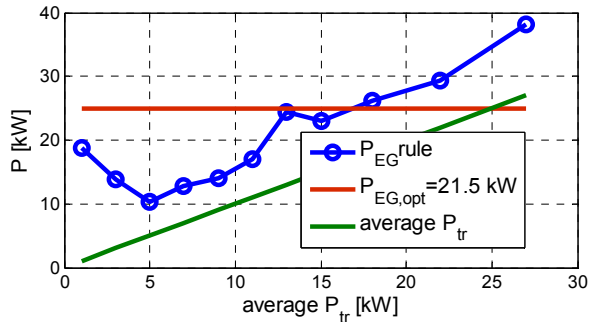

Fig. 16. Optimal generator power vs. average vehicle power for a hybrid electric vehicles with series structure.

electric losses, the optimal choice of generator power in a series hybrid depends in complex way from vehicle power, and that optimal engine power corresponds to the maximum engine efficiency conditions only in a limited power range. A more detailed analysis is reported in the cited paper (Rizzo et al., 2010).

The importance of thermal transients in start-stop operation over fuel consumption and emissions, neglected in most models used for energy management in hybrid vehicles, has been also demonstrated by recent experimental studies (Ohn et al., 2008).

A method for fuel consumption minimization in a Hybrid Solar Vehicle based on application of Model Predictive Control has also been recently proposed (Preitl et al., 2007).

3.5 Effects of panel position and use of moving roofs

In most of solar cars, solar panels are fixed and located at almost horizontal position. This solution, although the most practical by several points of view, does not allow to maximize the net power from the sun. In next figure the mean yearly incident energy corresponding to different position of solar panels is presented, for different latitudes. The data have been obtained by PVWatts (<http://www.pvwatts.org/>), based on a database of real data covering about 30 years, for different locations in USA.

It can be observed that, with the adoption of a self-orienting solar roof (2 axis tracking), there is an increase of incident energy, varying from about 800 to 600 kWh/m²/year, from low to high latitudes. In terms of relative gain, a moving panel would increase the solar contribution from about 46%, at low latitudes, up to 78%, at high latitudes. Of course, the

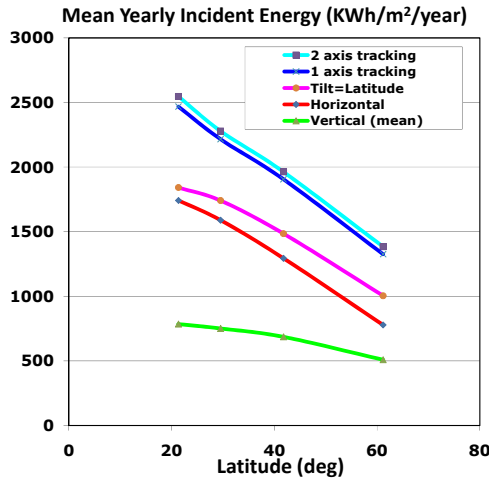

Fig. 17. Effects of panel position and latitude on incident energy

adoption of a moving panel could be feasible only for parking phases, where on the other hand many cars in urban environment spend most of their time. The real benefits would be lower than the ones indicated in the graph, due to the energy spent to move the panel and to possible kinematic constraints preventing perfect orientation. Also, in order to maximize the solar contribution, transparent panel could be incorporated in the windows, and the lateral surface of a car could be also covered by solar panels, as for instance in FIAT Phylla. An estimation of the increase in incident energy can be obtained by considering the mean incident energy on a vertical surface, with random orientation: with respect to the energy incident at horizontal position, their contribution is about 45%, at low latitudes, but up to 65% at higher latitudes.

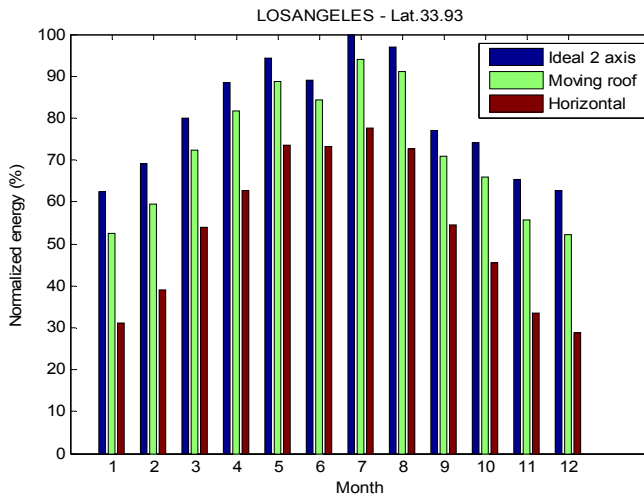

Fig. 18. Energy collected with various options of solar roof (Los Angeles, 1988)

It therefore emerges that the adoption of a moving roof for parking phases, and the utilization of windows and lateral surfaces too, would allow a significant increase of incident energy with respect to the sole utilization of the car roof. Moreover, this increment is particularly significant at high latitudes, so contributing to enlarge the potential market of solar assisted vehicles.

A study on the benefits of a moving solar roof for parking phases in a Hybrid Solar Vehicle has been recently presented (Coraggio et al., 2010). A kinematic model of a parallel robot with three degrees of freedom has been developed and validated over the experimental data obtained by a small scale real prototype. The effects of roof design variables are analyzed, and the benefits in terms of net available energy assessed by simulation over hourly solar data at various months and latitudes (Fig. 18).

3.6 Upgrade of conventional vehicles

A possible remark is that, considering the current economic crisis, it is unlikely that, in next few years, PV assisted EV's and HEV's will substitute for a substantial number of conventional vehicles, since relevant investments on production plants would be needed. This fact would of course impair the global impact of this innovation on fuel consumption and CO₂ emissions, at least in a short term scenario. Therefore, one may wonder if there is any possibility to upgrade conventional vehicles to PV assisted hybrid. A proposal of a kit to be distributed in after-market has been recently formulated and patented by the author (www.hysolarakit.com). Mild-solar-hybridization will be performed by installing in-wheel electric motors on the rear wheels (in case of front wheel drive) and by the integration of photovoltaic panels on the roof. The original architecture will be upgraded with the an additional battery pack and a control unit to be faced with the engine management system by the OBD port. The Vehicle Management Unit (VMU), which would implement control logics compatible with typical drive styles of conventional-car users, receives the data from OBD gate and battery (SOC estimation) and drives in-wheel motors by properly acting on the electric node EN (Fig. 19). A display on the dashboard may advice the driver about the actual operation of the system. The project has been recently financed by the Italian ministry of research (www.dimec.unisa.it/PRIN/PRIN_2008.htm). The results will be published shortly, and presented on the cited websites.

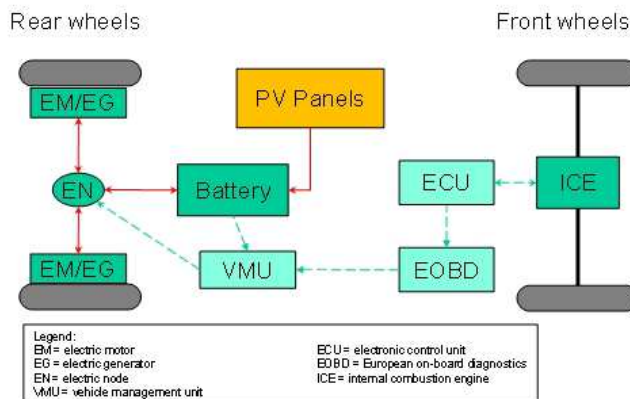

Fig. 19. Scheme of a system to upgrade a conventional car to Mild Hybrid Solar Vehicle.

4. Conclusion

The integration of photovoltaic panels in hybrid vehicles is becoming more feasible, due to the increasing fleet electrification, to the increase in fuel costs, to the advances in terms of PV panel technology, and to the reduction in their cost. Hybrid Solar Vehicles may therefore represent a valuable solution to face both energy saving and environmental issues. Of course, these vehicles cannot represent a universal solution, since the best balance between benefits and costs would depend on mission profile: in particular, significant reductions in fuel consumption and emissions can be obtained during typical use in urban conditions during working days. Moreover, the integration with solar energy would also contribute to reduce battery recharging time, a critical issue for Plug-in vehicles, and to add value for Vehicle to Grid applications.

Putting a solar panel on an existing hybrid vehicle may be just the first step: in order to maximize their benefits, re-design and optimization of the whole vehicle-powertrain system would be required. Particular attention has to be paid in maximizing the net power from solar panels, and in adopting advanced solutions for power electronics. Moreover, these vehicle would require specific solutions for energy management and control, whit more advanced look-ahead capabilities.

The adoption of moving roofs for parking phases and the use of solar panels on windows and lateral sides would enhance solar contribution, beyond the classical fixed panel on the car roof. Moreover, these solutions would reduce the gap between solar contribution at low and high latitudes, so extending the potential market of these vehicles. Interesting opportunities are also related to possible reconversion of conventional vehicles to Mild Hybrid Solar Vehicles, by means of kits to be distributed in after-market.

The perspectives about cost issues of hybrid solar vehicles are encouraging. Anyway, as it happens for many innovations, full economic feasibility could not be immediate, and a financial support from governments would certainly be appropriate. But the recent and somewhat unexpected commercial success of some electrical hybrid cars indicates that there are grounds for hope that a significant number of users is already willing to spend some more money to contribute to save the planet from pollution, climate changes and resource depletion.

5. References

- Adinolfi G., Arsie I., Di Martino R., Giustiniani A., Petrone G., Rizzo G., Sorrentino M., (2008), "A Prototype of Hybrid Solar Vehicle: Simulations and On-Board Measurements", Proc.of Advanced Vehicle Control Symposium AVEC 2008, October 6-9, 2008, Kobe (Japan) 917-922 Society of Automotive Engineers of Japan - ISBN: 978-4-904056-21-9
- Arsie, I., Rizzo, G., Sorrentino, M., (2006) "Optimal Design and Dynamic Simulation of a Hybrid Solar Vehicle", SAE paper 2006-01-2997, SAE 2006 Transactions - Journal of Engines, vol. 115-3, pp. 805-811.
- Arsie, I., Rizzo, G., Sorrentino, M., (2010) "Effects of engine thermal transients on the energy management of series hybrid solar vehicles", Control Engineering Practice (2010), DOI:10.1016/j.conengprac.2010.01.015.

- Arsie I, Rizzo G, Sorrentino M (2009) Genetic Algorithms Based Optimization of Intermittent ICE scheduling on a Hybrid Solar Vehicle In: European Control Conference 2009, ECC09, Budapest, August 23-26, 2009.
- Arsie I., Rizzo G., Sorrentino M. (2008) A Model for the Optimal Design of a Hybrid Solar Vehicle Review of Automotive Engineering, Society of Automotive Engineers of Japan (JSAE), 2008, ISSN 1349-4724. 29-3: 439-447
- Arsie I., Rizzo G., Sorrentino M. (2007) Optimal Design and Dynamic Simulation of a Hybrid Solar Vehicle, SAE TRANSACTIONS- JOURNAL OF ENGINES 115-3: 805-811
- Cacciato M., Consoli A., Scarcella G., Testa A. (2004), "A Multhi-Phase DC/DC Converter for Automotive Dual-voltage Power Systems" IEEE Industry Applications Magazine, November/December 2004, pp. 2-9.
- Cacciato M., Consoli A, Scarcella G, Scelba G. (2007), Accurate Implementation of a State of Charge Estimator for Hybrid and Elecric Vehicle Battery Packs. 2nd International Workshop on Hybrid Vehicles. 14 September, 2007. (pp. 1-6). Salerno, Italy.
- Coraggio G., Pisanti C., Rizzo G., Sorrentino M. (2010, I), Assessment of benefits obtainable in a Hybrid Solar Vehicle using look-ahead capabilities for incoming solar energy, 10th Intl. Symp. On Advanced Vehicle Control, August 22-26, 2010, Loughborough (UK).
- Coraggio G., Pisanti C., Rizzo G., Senatore A. (2010, II), A Moving Solar Roof for a Hybrid Solar Vehicle, 6th IFAC Symposium on Advances in Automotive Control, July 11-14, 2010, Munich (D).
- Egiziano L., Giustiniani A., Lisi G., Petrone G., Spagnuolo G., Vitelli M.(2007): "Experimental characterization of the photovoltaic generator for hybrid solar vehicle". Proc of 2007 IEEE International Symposium on Industrial Electronics, June 4-7 2007 Vigo (Spain), pp 329-334.
- ESA, Electricity Storage Association, www.electricitystorage.org
- Femia N., Lisi G., Petrone G., Spagnuolo G., Vitelli M. (2008), "Analysis of Photovoltaic Systems with Distributed Maximum Power Point Tracking", Proc. of IEEE International Symposium on Industrial Electronics ISIE08, June 30-July 2 2008 pp. 2408 - 2413.
- Fischer R. (2009), AVL List GmbH, The Electrification of the Powertrain - from Turbohybrid to Range Extender, 30. Internationales Wiener Motorensymposium 2009
- Guzzella L. and Amstutz A. (1999), CAE Tools for Quasi-Static Modeling and Optimization of Hybrid Poweretrains. IEEE Transactions on Vehicular Technology, vol. 48, no. 6, November 1999.
- Hohm, D.P.; Ropp, M.E., (2000), "Comparative study of maximum power point tracking algorithms using an experimental, programmable, maximum power point tracking test bed", Conference Record of the Twenty-Eighth IEEE Photovoltaic Specialists Conference, 2000. 15-22 Sept. 2000, pp:1699 - 1702
- Jain, A.; Sharma, S.; Kapoor, A., (2006), "Solar cell array parameters using Lambert W-function", Solar Energy Materials & Solar Cells 90 (2006) 25-31
- Kassakian, J.G. (2000), Automotive Electronics Power Up IEEE Spectrum, Volume: 37, Issue: 5 May 2000, Pages:34 - 39
- Kempton W., Tomić J., Letendre S., Brooks A., Lipman T. (2001), "Vehicle-to-Grid Power: Battery, Hybrid, and Fuel Cell Vehicles as Resources for Distributed Electric Power

- in California", Report prepared for California Air Resources Board and the California Environmental Protection Agency, 2001.
- Letendre S., Perez R., Herig C. (2003), Vehicle Integrated PV: A Clean and Secure Fuel for Hybrid Electric Vehicles, Proc. of the American Solar Energy Society Solar 2003 Conference, June 21-23, 2003, Austin, TX.
- Liu, S., Dougal, R.A. (2002), "Dynamic multiphysics model for solar array", IEEE Trans. On Energy Conversion, Vol. 17, No. 2, June 2002, pp. 285-294.
- Neil C. (2006), Solar Hybrid Vehicles,
http://www.energypulse.net/centers/article/article_display.cfm?a_id=1267
- Preitl Z., Bauer P., Kulcsar B., Rizzo G., Bokor J. (2007), Control Solutions for Hybrid Solar Vehicle Fuel Consumption Minimization In: Proceedings of the 2007 IEEE Intelligent Vehicles Symposium, Istanbul, Turkey, June 13-15, 2007.
- Quaschnig V. (2003), "Technology fundamentals - The sun as an energy resource". Renewable Energy World 6 (5): 90-93.
- REN21, Renewables - Global Status Report - 2009 Update,
http://www.ren21.net/pdf/RE_GSR_2009_update.pdf
- Rizzo G., (2010), Automotive Applications of Solar Energy, 6th IFAC Symposium on Advances in Automotive Control, July 11-14, 2010, Munich (D).
- Rizzo G., Sorrentino M., (2010), Introducing Sunshine Forecast to Improve On-Board Energy Management of Hybrid Solar Vehicles, 6th IFAC Symposium on Advances in Automotive Control, July 11-14, 2010, Munich (D).
- Segal A., Epstein M., Yogev A., (2004), Hybrid concentrated photovoltaic and thermal power conversion at different spectral bands, Solar Energy 76 (2004) 591-601
- Smil V., (2006), Energy at the Crossroads, Global Science Forum Conference on Scientific Challenges for Energy Research, Paris, May 17-18, 2006,
<http://www.oecd.org/dataoecd/52/25/36760950.pdf>
- Statistics for Road Transport, UK Government,
<http://www.statistics.gov.uk/CCI/nscl.asp?ID=8100>
- Thilagam, A., Singh, J., Stulik, P., (1998), Optimizing Gallium Arsenide multiple quantum wells as high-performance photovoltaic devices, Solar Energy Materials and Solar Cells, Vol: 50, 1-4, January, 1998 pp. 243-249, Elsevier



Solar Collectors and Panels, Theory and Applications

Edited by Dr. Reccab Manyala

ISBN 978-953-307-142-8

Hard cover, 444 pages

Publisher Sciyo

Published online 05, October, 2010

Published in print edition October, 2010

This book provides a quick read for experts, researchers as well as novices in the field of solar collectors and panels research, technology, applications, theory and trends in research. It covers the use of solar panels applications in detail, ranging from lighting to use in solar vehicles.

How to reference

In order to correctly reference this scholarly work, feel free to copy and paste the following:

Gianfranco Rizzo, Ivan Arsie and Marco Sorrentino (2010). Hybrid Solar Vehicles, Solar Collectors and Panels, Theory and Applications, Dr. Reccab Manyala (Ed.), ISBN: 978-953-307-142-8, InTech, Available from: <http://www.intechopen.com/books/solar-collectors-and-panels--theory-and-applications/hybrid-solar-vehicles>

INTECH
open science | open minds

InTech Europe

University Campus STeP Ri
Slavka Krautzeka 83/A
51000 Rijeka, Croatia
Phone: +385 (51) 770 447
Fax: +385 (51) 686 166
www.intechopen.com

InTech China

Unit 405, Office Block, Hotel Equatorial Shanghai
No.65, Yan An Road (West), Shanghai, 200040, China
中国上海市延安西路65号上海国际贵都大饭店办公楼405单元
Phone: +86-21-62489820
Fax: +86-21-62489821

© 2010 The Author(s). Licensee IntechOpen. This chapter is distributed under the terms of the [Creative Commons Attribution-NonCommercial-ShareAlike-3.0 License](#), which permits use, distribution and reproduction for non-commercial purposes, provided the original is properly cited and derivative works building on this content are distributed under the same license.