

Mechatronics Design of an Unmanned Ground Vehicle for Military Applications

Pekka Appelqvist, Jere Knuutila and Juhana Ahtiainen
*Helsinki University of Technology
Finland*

1. Introduction

In this chapter the development of an Unmanned Ground Vehicle (UGV) for task-oriented military applications is described. The instrumentation and software architecture of the vehicle platform, communication links, remote control station, and human-machine interface are presented along with observations from various field tests. Communication delay and usability tests are addressed as well. The research was conducted as a part of the FinUVS (Finnish Unmanned Vehicle Systems) technology program for the Finnish Defense Forces. The consortium responsible for this project included both industry and research institutions. Since the primary interest of the project was in the tactical utilization scenarios of the UGV and the available resources were relatively limited, the implementation of the vehicle control and navigation systems was tried to be kept as light and cost-effective as possible. The resources were focused on developing systems level solutions.

The UGV was developed as a technology demonstrator using mainly affordable COTS components to perform as a platform for the conceptual testing of the UGV system with various types of payloads and missions. Therefore, the research methodology was rather experimental by nature, combining complex systems engineering and mechatronics design, trying to find feasible solutions. The ultimate goal of the research and development work was set to achieve high level of autonomy, i.e., to be able to realistically demonstrate capability potential of the system with the given mission. In this case, the test tasks were related to tactical reconnaissance and surveillance. The targeted end-result, task-oriented autonomous mission capability, means that the UGV is able to cope with the predefined tasks as autonomously as possible, requiring operator support only in demanding decision making and unexpected problem situations.

The contribution of this research relies in the systems level solution that combines autonomous motion and task execution capabilities of the UGV, as well as scalable level of autonomy to support the UGV operator. Additional contribution consists of systems integration and information flow between the higher level command & control site and the UGV remote control station. So far, there have been relatively few attempts to combine all these ambitious features in realistic field environment tests, especially in a cost-effective approach. Along with the presented UGV demonstrator case (see Fig. 1), the chapter provides for an overlook to the essential research problems and presents solutions used in

the domain of autonomous field robots. The research challenges are generic by nature in similar robotic systems.

The emphasis of this chapter is rather on practical observations and feasible solutions instead of describing algorithms in detail. Section 2 reviews similar UGV systems and their development, while generic design considerations of various subsystems are discussed in Section 3. Next, in Section 4, the implementation and design solutions of the UGV demonstrator systems are explained in detail. This is followed by the results and observations based on several demonstrations and field testing in Section 5. Finally, the achievements are concluded with the analysis of developed solutions and observations from the field tests.



Fig. 1. The fully instrumented UGV demonstrator at the primary test site.

2. Related Work

2.1 Historical perspective

The term Unmanned Ground Vehicle or UGV only defines that the operator controlling the vehicle, if one exists, is not on the vehicle itself. It does not specify the kind of control that an operator might have over the vehicle at any given time. Sheridan (1992) divides control modes into manual control, supervisory control and fully automatic control. Manual and supervisory modes can be further divided depending on the degree of computer involvement in the control loop. In this chapter we consider vehicles that can be used in any one of these modes, possibly in addition to manned driving. However, more emphasis is on the supervisory and autonomous modes since that is where most research is currently focused on. Sheridan does not give preference to any mode over another, but it is evident that systems with more autonomy also have to be technically more sophisticated. However,

after attaining full autonomy, adding high-level communication between human and the vehicle can be seen as an even higher level of sophistication as suggested by SPAWAR (2007a). In that classification, full autonomy is followed by semi-proximal autonomy and proximal autonomy. Semi-proximal autonomy signifies a mode where a robot can act as a guide to a human in unknown environment. Proximal autonomy is a mode where the human and the robot can cooperate on human terms. Also note that the term UGV does not rule out the possibility of human passengers on the vehicle. Such situations might arise within mass transport systems and military evacuation missions.

So far, the development and use of remotely controlled vehicles has been dominated by the military. During their existence, these vehicles have been a relatively high-tech and as such, quite expensive. The military however has had the need and the resources to develop and deploy systems that are able to successfully perform specific tasks that might be otherwise too costly. One of the earliest, if not the first, were German wire-guided electric boats during the First World War. These boats had an explosive charge on them and were steered into big, slow warships. (Lightoller, 1935; Neumann, 1921) In the Second World War, all the major parties had remote controlled systems. There were Soviet "TT-26" tanks (Armchair General, 2004), German "Goliath" tracked mines (Kaleun, n.d.) and U.S. "TDR" aircraft (SPAWAR, 2007b). Despite their technical similarity, the boats and tracked mines just mentioned and also guided torpedoes and cruise missiles - to name a few - are however not considered unmanned vehicles as they are destroyed when used.

The space race saw the deployment of Soviet planetary Lunokhod rovers on the Moon in the 1970's (Wade, 2008). Three U.S. rovers have successfully landed on Mars: Pathfinder in 1997, Spirit and Opportunity in 2003. The latter two are still operational (NASA 2009). While the Lunokhods were teleoperated, the same cannot be said for the Mars robots because the delay caused by the distance between Mars and the Earth makes it impractical. As a result, the Mars robots are programmable and more autonomous. Unmanned aerial vehicles are currently in use by armed forces all over the developed countries. The challenges on the ground - obstacles to moving, sensing and communicating - have proved much more difficult than in the air or under water.

Autonomous driving on roads and highways has been under development since the late 1960's when the available computing power allowed the first ones to be built. The early systems used only computer vision to track the road and lane markings. For a more detailed history on the development of unmanned ground vehicles, see "UGV history 101" (Cage, 1995). The VaMP ja VITA-2 vehicles developed by Universität der Bundeswehr München and Mercedes-Benz became a significant advance in unmanned ground vehicle technology (Schmidhuber, 2005) when they drove over 1000 km on highways in 1994. They reached speeds of 130 km/h and drove in heavy traffic, but required some human intervention (UniBwM, n.d.).

The state-of-the-art UGV projects around the world have proved that current autonomous UGV systems are capable of coping even in dynamic environments with high speeds. In the DARPA Urban Challenge (UC) competition (DARPA, n.d.), the vehicles had to navigate in an urban environment with other vehicles and perform a simulated logistics task. A digital map of the road network was provided, but some of the roads were blocked and the vehicles were required to use their sensors to detect the blocks and replan their route on the fly. Since then DARPA has not announced new competitions in the UGV domain. The UC competition showed that the Velodyne laser scanner (Velodyne, n.d.) is the best readily

available sensor for environment modeling at the moment. All the major teams that completed the UC used this sensor. It provides a very accurate model about the environment using a column of 64 vertically aligned laser beams that rotate at 5-15 Hz frequency.

In the Military ELROB event arranged in 2006 and 2008 (ELROB, n.d.), a different approach was chosen. It emphasized completing real military missions - such as detection of explosives and tactical awareness in urban reconnaissance - but the rules did not require fully autonomous vehicles. Practically all participating vehicles were purely teleoperated. In 2007, a civilian ELROB was arranged where the tasks were related to civilian scenarios such as improving situation awareness in an incident with improvised explosive devices (IED). Military and civilian versions alternate the annual ELROB event.

2.2 Current military systems

There are a number of small man-portable robots in military and police use. These are typically used to defuse bombs and other explosive devices and are remotely operated. The first two fully deployed vehicle-size autonomous unmanned systems are the Israel Aerospace Industries' Guardium Unmanned Security Vehicle (IAI, n.d.) and the MDARS developed by General Dynamics Robotic Systems (GDRS, n.d.). The Guardium is designed for guarding and surveillance tasks and it can both drive autonomously and be teleoperated. MDARS is developed to provide an automated intrusion detection and inventory assessment capability for use in warehouses and storage sites. In 2008, 24 MDARS systems were ordered and expected to be delivered in January 2009 (Washington Technology, 2008). A number of other vehicle-size systems exist, but they are more or less limited to direct teleoperation. Several implementations of remotely operated de-mining vehicles exist, but so do some more versatile vehicles such as the Accident Response Mobile Manipulator System (ARMMS) by Sandia (Sandia, 2008). The ARMMS is built on a HMMWV and is equipped with two manipulators in the front. Its main purpose is to act as a remotely operated vehicle in radioactive or otherwise hazardous environments.

Several research projects aim at developing more autonomous ground vehicles for military use. The most notable ones are being developed in the United States. R-Gator is a robotic version of the John Deere M-Gator, a multipurpose military transport vehicle. The R-gator seems likely to be deployed in the near future. It is able to follow a pre-defined path or a human and can also be controlled with a remote controller up to a distance of 300 m (John Deere, 2008). The MULE, part of the U.S. Army Future Combat System, is a 2,5 ton wheeled vehicle that is planned to have different versions for transport, countermine and assault (U.S. Army, 2008). Research projects have taken place around other similar vehicle platforms such as the TAGS-CX by Foster-Miller and Spinner, Crusher and Autonomous Platform Demonstrator by the National Robotics Engineering Center (NREC), part of the Carnegie-Mellon University Robotics Institute. NREC has also been developing the Gladiator, an armed vehicle-size unmanned vehicle for the U.S. Marines (NREC, n.d.).

2.3 Commercial civilian systems and autonomous features in cars

The term unmanned vehicle usually implies military applications. The same technology in civilian applications is often called driverless, automatic, autonomous or robotic. A number of such mass transport systems are in use. Most of these are trains, but also road vehicle

systems such as the ParkShuttle and Phileas (Lohmann, 2007). Industrial solutions such as the Sandvik Automine (Sandvik, 2008) or Brisbane harbour automatic container terminal (Tekes, 2006) also make use of unmanned vehicles in material handling. All current systems work in structured environments and are typically restricted to moving in an area with no humans present due to safety reasons.

Teleoperation kits or systems to convert a traditional vehicle to a remotely controlled one also exist. Some of these systems such as the Pronto4 by Kairos Autonomi state that they can be installed in a matter of hours on any wheel operated vehicle (Kairos Autonomi, n.d.).

Vehicle automation features are becoming increasingly common in private cars. A modern car typically has several processors taking care of engine and transmission control, anti-lock brakes and vehicle stability to name a few. These are not any more the "smart features" that get special attention from consumers. More advanced systems include sensors that can sense the environment outside the vehicle. The currently new vehicle automation features can control the speed or position of the vehicle or help the driver to do it.

Adaptive cruise control (also active cruise control and intelligent cruise control) typically uses a radar or laser scanner to measure distances to the obstacles in front of the car. The cruise control system can then adjust vehicle speed to match the speed of the vehicle driving in front and keep sufficient distance to it. Some of these systems can also apply the brake to avoid collisions or lessen the damage of an unavoidable collision.

Intelligent speed adaptation is a system where the vehicle can access a database of speed limits to determine the currently active one for the vehicle. This information can be used to limit the speed that the vehicle can be driven at, or it can use force-feedback on the accelerator pedal so that the driver feels it in the pedal when he is speeding.

Lane departure warning systems use cameras to monitor lane markings. If the driver is about to exit the lane without signaling, the system alerts by vibrating the steering wheel. Some systems include lane keeping assistance by applying the brake on the opposite side or by steering to keep the vehicle in the lane. The manufacturers stress that the driver still has to be alert and driving.

Parking automation systems are also becoming more common. These systems can parallel park between obstacles on the side of the road. The system takes care of steering and the driver typically has to control the vehicle speed.

Automated highway systems are systems where the vehicles can communicate and cooperate to drive automatically in queues. The aim is on the other hand to improve safety and on the other, lower the consumption of the vehicles. When the vehicles are able to communicate, they can brake simultaneously. This allows shorter distanced between cars and thus lower consumption. No systems exist, but a demonstration of such a system has been held in 1997 (PATH, n.d.).

3. Design Considerations

The development of the UGV demonstrator was divided into three phases in the project plan. In the first phase the vehicle was instrumented for computer controlled operation. The UGV consists of subsystems that were: locomotion system, energy system, positioning system, sensor system, navigation system, motion control system and communication system. Naturally, there is also a need for an interface for human-machine interaction (HMI). In case the UGV is used for actual missions, there is also a need for mission control

system and if there is some mission specific payload there has to be a control system for the payload. Due to the limited resources and focusing in the UGV project, the actual implementation of the UGV demonstrator was a so called minimum realization. This means that COTS components were used whenever possible and the number of sensors was kept as low as possible. Resources were aimed for developing software rather than hardware. Overall architecture of the UGV demonstrator was designed according to the figure 2 where most of the main components of the UGV demonstrator are shown. The remote control station is shown in gray and the white boxes represent the actual vehicle. Next subchapters summarize the design considerations related to each subsystem of the UGV demonstrator and explain the figure 2 in detail.

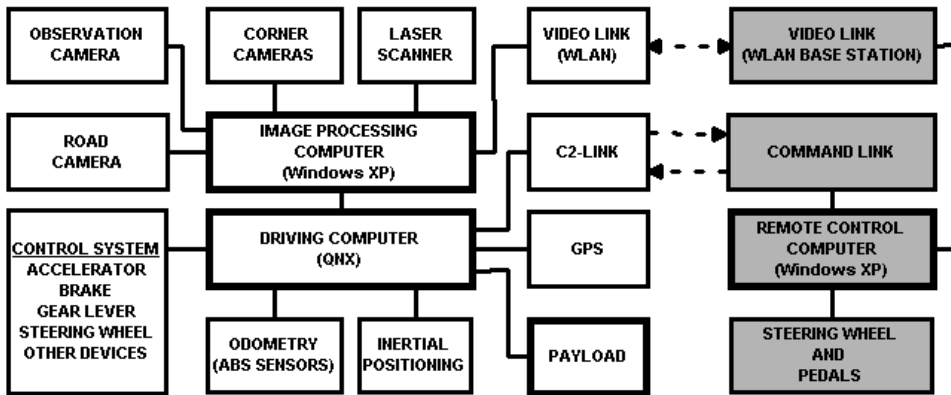

Fig. 2. Block diagram of the UGV demonstrator. Remote control station is represented by the gray boxes on the right while the white boxes represent the vehicle.

Locomotion system

The UGV demonstrator locomotion system consists of the vehicle platform together with its instrumentation. A decision to use a commercial off-road vehicle was made early in the project. This way sufficient off-road capability and reliability of the basic mechanics was ensured. Also, vehicles of this size can travel reasonably long distances and carry a wide range of payloads. Another decision made at that point was that the vehicle should remain street legal, which greatly simplifies the logistics in testing. This means that the computer control and the drive-by-wire capability of the platform had to be made using the control system of the vehicle. The actuators that drive the vehicle controls had to be detachable so that the vehicle can be safely driven on public roads by human driver.

It was decided that the drive-by-wire capability will be implemented entirely with electrical actuators due to their ease of use and relatively small size. Pneumatic and hydraulic actuators were also considered, especially for the brake pedal control which requires considerable force. However, the force required to fully apply the brake was measured and it was deemed possible to achieve the same force with a linear electric actuator. The decision that the vehicle must remain street legal dictated where the actuators would be installed, since no disturbance for the human driver was allowed. Achieving drive-by-capability with external actuators is not the optimal way since there are always unnecessary gaps in the

installations and the control circuits are therefore hard to tune. An ideal platform for a UGV system would be a vehicle that has electric actuators integrated on it at the factory. This way it would be possible to connect straight to the vehicle bus and send drive commands to the on-board computer. Also, with a vehicle with a vehicle data bus it is possible to read all the information related to the vehicle from the bus. In our case there was no such bus in the vehicle.

Energy system

All the components in the figure 2 are electric so there is a clear need for an additional energy system. The additional energy system was part of the design from the start and the idea was that there would be enough capacity in the batteries to supply power for all the devices for several hours. Another design criterion was that that the energy system should be able to provide both 12 and 24 volts. Also, the batteries should be charged when the engine is running. A rectifier and additional charger that use electricity from an electric socket were also taken into consideration. With these components the batteries could be charged in a garage when the engine is not running and the UGV demonstrator could be powered through the rectifier, not charging the batteries.

Positioning system

Positioning the vehicle precisely enough is essential for autonomous operation. It was known that a GPS receiver by itself would not provide accurate enough information. Therefore it was necessary to add other positioning methods. Using an inertial navigation system (INS) based on gyroscopes and accelerometers together with dead reckoning calculations it is possible to get the position estimate accurate enough. So, the positioning system of UGV demonstrator, shown in figure 2, was designed to involve GPS-receiver, inertial positioning device and odometry sensors for travelled distance and steering angle. Fourth method for improving the position estimate is video navigation based on processing image flow and laser scanner data.

Sensor system

A dynamic model of the environment is acquired and updated through the sensor system. The sensor system of the UGV demonstrator consisted of three cameras and two single line laser scanners. Due to the limited resources, the plan was to use as few sensors as possible. Sensors are shown in the upper left corner of the figure 2. With these sensors it is possible to demonstrate the functionality of the system, but the reliability and performance will not be as great as they could be due to the inaccurate environment model. The environment model could be improved with the help of more sensors. For example, a Velodyne lidar would improve the model dramatically. The cameras were designed mainly for teleoperation purposes and the laser scanners for the autonomous mode for obstacle avoidance.

Navigation system

Navigation system is responsible for providing the route points for a UGV system. The navigation system of the UGV demonstrator was based on the idea that the vehicle was intended to use roads and open fields. There are accurate digital road maps of the Finnish roads available for a fee. Even the small forest roads are mapped. The operator can design the route for the vehicle with the help of digital map material. Only in case of an obstacle the navigation system would plan a route around it. In case there is need for off-road driving,

the operator would have to plan the route by hand or teleoperate the vehicle through the off-road part. No map is created in the vehicle during runtime. In our demonstrator, we deemed it simpler and cheaper to record a suitable digital map of roads than use a commercial one.

Motion control system

Motion control system is the low level system which executes the drive commands that are given from upper level system. In the teleoperation mode the motion control system executes the commands given by the remote control station. In the autonomous mode, the commands are given by the navigation system, which is trying to maintain the given velocity and position on the route. In the UGV demonstrator the motion control system includes the control loops of the actuators which drive the vehicle controls. Also the speed controller and path follower belong to the motion control system.

Communication system

Communication between the vehicle and the remote control station is necessary, even though fully autonomous vehicle would not necessarily need a communication link. The communication link is an essential part of the teleoperation capability and also very useful in the autonomous mode. A reliable, long range and high-bandwidth link was needed, but such radio modems were not yet available, at least not for a reasonable cost. This is of the biggest limiting factors in the UGV domain. A low-bandwidth but reliable tactical radio was used for the command and control (C2) data and a high-bandwidth video-link was used for transmitting the video feed.

Remote control station and HMI

The remote control station consists of a laptop computer running the user interface application for the vehicle, steering wheel and pedals and radio equipment. Another laptop can be added for payload control.

Human-machine interaction was a notable part of our research. Since fully autonomous task execution in hostile environments is not yet - if ever will be - practical, several modes of operation were employed. The idea was that there should be intermediate modes between direct teleoperation and the fully autonomous mode. The transfer or division of control between a human operator and computer - scalable level of autonomy - was one focus area of the project.

Safety issues

The starting point in the design of the UGV demonstrator was to construct such an emergency stop circuit (ESC) that the vehicle could be stopped at any time. All the thinkable malfunction scenarios were taken into account when designing the circuit. It is important that there is no software in the loop. The ESC was designed so that it activates if the software in the driving computer crashes, connection is lost or the system loses power. The ESC can also be activated manually, using emergency stop buttons or by software from the remote control station. When the ESC is activated, the brake pedal is applied fully and accelerator pedal is released. Stalling the engine was considered, but deemed not necessary.

4. Implementation

In this chapter the implementation of the UGV demonstrator is explained in detail. The chapter is divided into two main parts - the implementation of the hardware and the software systems of the vehicle.

4.1 Hardware Implementation

Drive-by-wire capability was realized with electric actuators that drive the control devices of the vehicle. Actuators were installed so that they can be detached from the vehicle controls when driving manually. This way the vehicle remains street legal and is safe to drive among normal traffic. With street legal vehicle there was no need for complicated and costly transportation arrangements.

All the actuators that drive the control devices were sized so that they fit the planned positions, but also that they have enough power to use the control devices in all situations. Measuring the needed force to use the control devices was done with standard scales. It was taken into consideration that the power steering and the brake booster are not in use when the engine is not running.

The vehicle is equipped with automatic transmission and the gear lever, situated in the middle console, was instrumented by a detachable linear actuator (see Fig. 3). The actuator has two limit switches and an incremental encoder integrated inside it. When the software is started the motor needs to be calibrated. Calibration is done by driving the motor to its limit where a limit switch stops the motor. That position becomes the reference point. Also, every time either of the limit switches is activated, the position is calibrated again in case some inaccuracies would have occurred. After the calibration, the position of the gear lever can be calculated from the encoder pulses. All gear lever positions are achievable with this arrangement.

The steering wheel is actuated using a brushed DC-motor attached to a stand built in place of the removed center console. The motor is attached to the steering wheel with a toothed belt and a belt-pulley arrangement shown in figure 3. The toothed belt can be detached from the steering wheel after which a human driver can turn the wheel normally. The steering angle is measured underneath the vehicle from the push-rod that mechanically turns the wheels. A linear micropulse transducer with IP 67 (internal protection) was used. Linear potentiometer was tried but it did not endure the harsh conditions. Vibrations wore the conducting surface off from the middle point.

The brakes are actuated using the brake pedal to keep human operability at all times. The brake pedal is operated by a linear actuator. It is not attached to the pedal but it only pushes it allowing "safety driver" to step in any time and override the computer control. This greatly improves safety during testing. The throttle pedal is actuated similarly. Pushing the brake pedal to the floor required quite a lot of power and it was hard to find suitable actuator, because selecting spindle motor it is always a tradeoff between power and speed. The selected motor has just enough power to press the brake pedal to the floor when the brake booster is off. However, with the brake booster on, there is more than enough braking power. When driving on a public road, the actuators can be driven to the uppermost position and powered down so there is no danger of them interfering with the human driver's vehicle handling. The actuators are equipped with potentiometers that tell their absolute position. These signals are used as the feedback signal on the control loops. The

motors are also equipped with limit switches that prevent the motors exceeding their range of movement.



Fig. 3. Steering wheel is instrumented with brushed DC-motor and belt-pulley arrangement. Gear lever is instrumented with a spindle motor. Instrumentation was tested and the controllers were tuned by using the steering wheel shown on the right.

Remote ignition of the engine is instrumented with relays. It is assumed that the key in the ignition lock disabling the vehicle immobilizer and the steering lock. Feedback signal from the tachometer is used to determine whether the engine is running or not and the feedback signal from the annealing indicator reveals when the combustion chamber is warm enough to try starting (diesel engine). One relay switches on the power and another rotates the starter motor. Operator has to only press ignition button in UI, the software module takes care of everything else.

Also the windshield wipers and the windshield wash functions are instrumented. This is also done by connecting a computer controllable relays in parallel to vehicles own wires.

Safety

Instrumentation of the pedals was designed keeping also the safety issues in mind. When the ESC activates, the brake pedal is pushed to the floor and the throttle pedal is released. This is achieved by conducting electricity straight from the battery to the motors until limit switches break the circuit. In practice, the only definite way to stop the vehicle would

require stalling the engine, but the ESC proved to be fully reliable so, for convenience's sake, the engine was left running. The ESC is connected to the driving computer with an external watchdog circuit. When the software is running, it feeds a rectangular wave signal to the watchdog circuit at a specific frequency. In case the software crashes, the watchdog circuit no longer receives the signal and activates the ESC. The ESC can also be activated within the software from the remote control station or manually using one of the six emergency stop buttons mounted on the vehicle. In case of a radio connection loss, the ESC is activated by the driving computers software. Also, in the event of electrical power loss, the ESC will be activated.

Sensors

Most of the necessary sensors for unmanned operation are mounted on the roof rack of the vehicle (see Fig. 1). The observation camera which turns 360° is mounted in the middle of the roof rack in a shielded dome which protects the camera from the weather. In the dome there is a heater element that keeps the camera functional even at freezing outside temperatures. Four corner cameras were installed for the observation of the immediate surroundings of the vehicle. Another laser scanner, used for obstacle detection, is installed in the middle of roof rack's front part and directed towards the ground approximately 9 m in front of the vehicle. The other scanner is installed on the bumper and it looks straight forward. Both scanners are also waterproof and equipped with heater elements. The roof rack features also two WLAN antennas, two radio antennas and a beacon. The road camera is mounted to the rear view mirror stand, looking straight ahead through the windshield. In addition, depending on the mission, some payload can be attached to the roof rack as well.

Positioning of the vehicle is done by fusing data from GPS receiver, inertial navigation system (INS) and dead reckoning calculations. Also, video navigation was used to detect wheel tracks and road boundaries. The GPS receiver is standard COTS receiver with SIRF star III -chip and it is installed to the front bumper of the vehicle. The GPS receiver used to be on the roof as well but was installed on the front bumper after it was discovered that it was interfered by the transmitting radio of the C2-link with full power. On the bumper, where the distance to the transmitting antenna was twice as much, the interference was manageable.

Inertial measurement unit is a military-grade equipment and it is bolted to the centre of the vehicle chassis. Travelled distance used in dead reckoning calculations is computed from the filtered signals of the ABS-sensors. The signal from the ABS-sensors is sine wave which amplitude and frequency depends on the speed of rotation. Therefore, some custom made electronics was needed to generate pulses that are readable by the I/O-board of the driving computer. Steering angle used needed in dead reckoning calculations is the same one used in the control loop of the steering wheel.

Electricity

All the electric components mounted in the vehicle are powered by an additional electricity system which is completely separate from the vehicles own electric system. Energy is provided by a 2 kW generator which is belt driven by the engine. The generator is installed under the hood replacing the air-con compressor. Two 12 V, 75 Ah lead-acid gel batteries connected in series are used as a buffer and storage. Three DC/DC converters, two for 24 volts and one for 12 volts, provide regulated power for the electrical systems. It was

calculated that with all the electric components on, the batteries will last at least three hours. The batteries are also chargeable with a 24 volt charger installed to the poles of batteries. This charger is to be connected to 230 volts of alternating current. With a single switch it is possible to electrify the vehicle with external rectifier which also uses 230 Volts. Rectifier is needed because the 24 volt charger does not provide enough current to electrify all the electric components and charge the batteries at the same time.

Computers

The heart of the vehicle is a shock isolated rack behind the front passengers' seat where two computers and other electronics are mounted. Image processing computer is intended mainly for processing the camera and laser scanner data and driving computer for real-time drive command execution. The shock-isolation is needed because of vibration and trembling. In addition, the hard drives were installed in foamed plastic. The computers have been assembled from selected components and they feature ATX motherboards with 1.86 GHz Pentium-M processors. These mobile processors were selected because of their low power consumption and thus low heat dissipation.

Communication

Several options were considered when selecting the communication equipment. A reliable, long-range, but low-bandwidth command and control (C2) link and a high-bandwidth video link were needed.

A tactical, vehicle radio was selected as C2 link for its long range. For the video link, WLAN was chosen as the most practical possibility with the hope that superior solutions – such as mobile WiMAX or a tactical broadband solution – will replace it later.

The used WLAN for the image data is based on IEEE 802.11b, using the 2.4 GHz ISM (Industrial, Scientific and Medical) frequency band, which is quite a high frequency for non-line-of-sight operation in typical Finnish forest environment. Water molecules (e.g. in foliage, snow) absorb radio waves at this particular band, causing further attenuation to the signal. The band has fairly low transmitting power restrictions (20dBm, 100mW) in Finland. With special permission we were able to purchase and use high-power equipment (30dBm, 1W). The remote control station uses horizontally omnidirectional 15 dBi antennas. The vehicle has physically smaller, more convenient 8 dBi antennas. Both the vehicle and the remote control station use double antenna setup to minimize shadow zones.

4.2 Vehicle Software Architecture

Three or four computers, depending on the setup, are used in the system, two of which are in the vehicle. The driving computer takes care of vehicle real-time control, which is why it runs QNX Neutrino RTOS 6.3. The image processing computer runs Windows XP, taking care of grabbing the road camera image, reading the laser scanner data and processing of both. It is possible to use two computers in the remote control station, one for operating the vehicle and another for mission specific payload.

The software architecture of UGV demonstrator is shown in figure 4. Image processing computer is illustrated with a circle in the lower left corner of the figure and the remote control station with the rectangle in the same corner. The rest of the figure represents the software architecture of the driving computer.

There is also a possibility to link the remote control station to Command, Control, Communications, Computers and Intelligence (C4I) system, from where the missions are actually given to the operator who formulates the mission for use of one UGV. The system is designed so that one operator could control a fleet of vehicles at the same time.

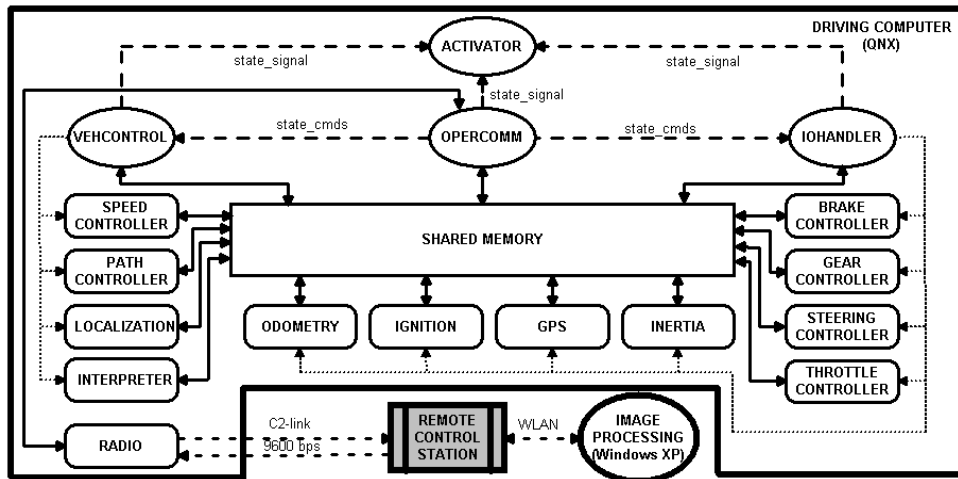

Fig. 4. Software architecture of the driving computer.

Driving computer

Software of the driving computer is based on processes, threads, signals and shared memory. A diagram of the software architecture is shown in figure 4. Parallel processes are represented by circles, and threads running inside them are represented by rounded rectangles. The core of the software, shared memory, is described with vertical rectangle. Every process and thread has access to its reading and writing routines.

First the ACTIVATOR process creates the shared memory and then starts all the other processes and monitors their state. In case the activator does not get a state signal from any of the processes within a specified time frame, it shuts down the software in a safe and controlled way. The OPERCOMM process handles the radio communication between the vehicle and the remote control station through the radio thread. It starts the radio connection thread, interprets the commands received from the remote control station and replies to each with an acknowledgment (ACK) message. The values received are written to the SHARED MEMORY, from where the controller threads read them periodically. If there are mode change commands in the message, opercomm will send appropriate signals to the other processes. In case the radio connection is lost, opercomm will also set on the emergency brake mode. The VEHCONTROL process is not in use while teleoperation mode is selected. It is designed with the threads it creates for autonomous use of the vehicle. The IOHANDLER creates and monitors the threads which control the actuators used to operate the vehicle's control system or read different sensors.

State machine

The whole software of the driving computer is based on state machine described in figure 5. When the software is started every thread and process are in a state called INITIALIZING. If something does not initialize right or software or hardware failure is detected, the software transits to SHUTDOWN state where the system is run down in a safe and controlled way. If the activator does not receive a state signal from any of the processes, regardless of the state, the software transits to the shutdown state. From initializing state, if everything is okay, the software goes to state MANUAL. In this state all the measurements are in use but actuator control is not available. This state is used for gathering data with a human driver. It is also a safe state to be in when the vehicle is stopped for a longer period of time, since the actuators are not in use. From MANUAL the software can transit either to TELEOPERATION, AUTOMATION or EMERGENCY_STOP. The POWER_SAVE state is not implemented but is an option designed for missions where the vehicle would need to stay in one place for days. This state is a sort of a stand by state in which all the unnecessary electric components are switched off. A timer signal would wake the system up. To implement this state some hardware changes would also be needed.

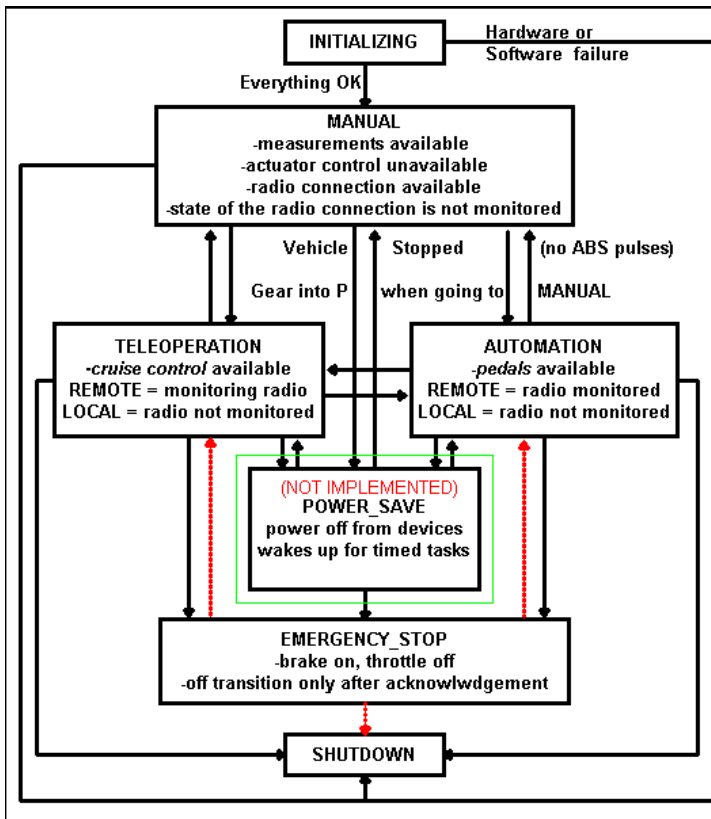

Fig. 5. Software of the driving computer is based on state machine.

The automation and teleoperation states, as their names suggest, are related to the degree of automation of the vehicle. In teleoperation state, the actuators are controlled directly from the remote control station. There is also an option where a cruise control can be set to assist the operator. The REMOTE and LOCAL flags tell whether the radio signal is monitored or not. In a local mode, the driving computer can be used to send control signals to vehicle. This sometimes handy state is only intended for testing purposes. In this state the radio signal is not monitored. When the remote flag is set, the radio signal is monitored and all the control signals come from the remote control station.

In the automation state, the local and remote flags are options as well. However, in this state the vehicle follows routes given by the operator, meaning that the vehicle follows some predefined waypoints. Only the supervision of the vehicle is left to the operator. In the automatic waypoint following mode it is also possible to leave the speed control for the operator: the operator controls the pedals of the vehicle but the steering wheel is under computer control. In the emergency stop state, the software control is overridden and the vehicle is stopped by activating the ESC with a computer controlled relay. To get out of this state a reset signal must be sent to the driving computer.

Image processing computer

The image processing computer acts as a server which the clients in the network can connect to and receive data from. The image processing computer grabs the image from the road camera, compresses it using a wavelet algorithm and transmits it to the client using UDP packets. The compression ratio can be selected at the remote control station. The observation camera is web browser based and it can be turned with buttons on the steering wheel at the remote control station. Image processing computer also processes the data from the laser scanner and is connected to the driving computer with a socket in order to exchange important information such as detected obstacles.

Remote control station and communication protocol

At the remote control station the vehicle can be controlled from a single laptop computer. Another laptop can be easily utilized for separate payload control. Vehicle control commands are transmitted through a military radio with a proprietary protocol that minimizes the necessary bandwidth and provides safety functions such as an emergency stop when the connection is lost. Communications between the vehicle computers and remote control station computers utilize a TCP and UDP packets over Internet Protocol. The higher level protocol to control the image processing functions is also proprietary. The observation camera uses an HTTP interface and vehicle payloads also have their own protocols.

The separate C4I system that was used to assign missions to the UGV demonstrator system and supervise their completion was connected through a local area network. The missions were defined in XML format and as such, could be transferred using a variety of methods such as low-bandwidth radios or a memory stick. In the demonstrations, a shared SQL database was used to record all mission-relevant data and allow the display of real-time data on the mission control system.

5. Milestone demonstrations and field tests

The UGV project plan included demonstrations meant to present the results of the work done and as an opportunity for the Finnish Defence Forces (FDF) to verify them and assess the potential usefulness of an unmanned vehicle. The demonstrations also served as project milestones and helped to stay focused on the current challenges.

Although to rough topics and dates were defined in the original project plan, the script of each demonstration was typically decided some months before. This decision was made on the basis of what was achievable, what was potentially most useful and interesting to FDF and also what was “demonstrable”, meaning things that can be seen and not only explained. Even if some features were developed and tested along the span of the project, not all of them were demonstrated because they were not working reliably enough. So the decision was made to concentrate on features that – if not unseen in the current unmanned vehicles – would make successful demonstrations more likely. The demonstrations themselves were more like displays of achievements, but it was all the testing and preparing for them that provided the project team with valuable experience.

The three demonstrations held during the project all took place on an island which is being used exclusively by the FDF. In the middle of the island there is a fairly large open area that has some obstacles such as trees, rocks and pits. Surrounding the open area there are forested areas with some unpaved roads cutting through them. In the demonstrations the open area and the roads were used to simulate a typical Finnish rural landscape.

Delay in the communication chain was measured and analyzed since the delay experienced by the operator is a critical aspect in teleoperation. By measuring the delay we were able to analyze the system performance and evaluate future communication solutions. Also, in an effort to gain a better understanding of the requirements for an unmanned vehicle user interface, separate teleoperation tests were arranged where “real” users were used to review the user interface. The test subjects were officers of the FDF chosen in an effort to find users that would match the potential real users of a UGV system.

5.1 Demo 1 - Teleoperation

The aim of the first demonstration was to demonstrate the completion of the essential instrumentation of the vehicle and the teleoperation capability and it was held in April 2006. Teleoperation was seen as the first stepping stone on the way to autonomous driving and also a required function in the final system, sort of a backup if the autonomy cannot cope with a situation. The demonstration not only presented the teleoperation but also the whole system setup including the instrumentation in the vehicle. The demonstrator system essentially included the vehicle and the remote control station where it was controlled from. The remote control station was set up in a vehicle field maintenance tent, provided by the army base. The remote control station with a laptop computer, wheel and pedals was located so that there was no direct view to the vehicle but the driver had to rely on the video feedback and other data provided by the demonstrator system.

The temperature on the day of the first demonstration was around zero degrees Celsius and the ground was covered with snow, slush and water. The plants and trees had no leaves except for the evergreen trees. The conditions were typical early spring in Finland.

The demonstration itself was the vehicle being driven in the field and along the forest road along a defined course. The total length of the course was in the order of two kilometres, the

furthest point being 500 meters from the remote control station. During the demonstration, driving speed was mostly around 20 km/h. The driver was one of the project members who had been responsible for developing the user interface.

After the demonstration, guests were given the opportunity to teleoperate the vehicle. This was to show that even though the system provided additional, more complicated functions, the basic driving is not very different from traditional driving.

The demonstration was a success as unmanned driving capability of the vehicle was achieved. The whole system was set up and made functional in a short time period of less than 9 months. However, there were notable restrictions, most of which were in some way related to the available resources. One of the main limitations was the communication link between the vehicle and the remote control station. For teleoperation, a fairly good quality video image is needed and in our setup, it was provided through 802.11 or WLAN connection. The connection is good as long as there is line of sight between the antennas but deteriorates with obstacles. Obstacles such as hills or buildings cut the connection instantly, but also vegetation and trees, even without foliage, becomes a factor within few hundred meters.

In our setup, the vehicle speed has no technical limitation. This means that the judgement is completely on the driver. The vehicle has been driven at a speed of 30-40 km/h in an area with no nearby obstacles. However, the real environment is very seldom free of obstacles and the speed has to be adjusted accordingly. The limiting factor in teleoperation systems is the delay in the control loop, or time that it takes from an driver action until the consequence of the action can be seen in the feedback. In our setup, this delay was in the order of 0.8-0.9 seconds (see section 5.4). This would allow somewhat higher speeds than what was used, but since the main focus was not on the speed, we opted for the increased safety margin instead.

5.2 Demo 2 - Path following and mission capabilities

The main goal of the second demonstration was to demonstrate the vehicle's ability to position itself, follow predefined paths and avoid obstacles. Demo 2 was held in April 2007. For autonomous navigation, the software in the vehicle had been improved to fuse positioning data from different sources: the GPS, the inertial navigation system (INS), odometry and laser scanner. Accurate positioning is the most essential requirement for autonomous driving.

Mission management was demonstrated by adding a separate C4I system with its own interface. The mission with its objective locations and tasks was planned using this interface. The mission was then transferred to the driver of the unmanned vehicle, who would plan the more precise execution of the mission. The demonstration mission included surveillance tasks but since the integration of the payload sensors was not yet complete, surveillance was done using the cameras already installed on the vehicle.

Several path segments in the demonstration area were defined and recorded by driving the vehicle along the paths and recording the integrated position information. These paths were stored in the vehicle and also copied to the remote control station to be displayed on the map interface. In the demonstration, the driver selected path segments to build up the complete route. The route also included points where the vehicle would stop. The vehicle drove through most of the path autonomously. The route was defined to include a more challenging part with narrow passages and nearby obstacles. To demonstrate the transitions

between autonomous driving and teleoperation, the driver took over the control of the vehicle, drove it through the challenging part and then handed control back to the vehicle computer. The transitions were done while the vehicle was moving to demonstrate that as long as both parties are aware of the current situation, the handover does not require a full stop and a new start.

The positioning turned out to be the main limiting factor for autonomous driving at this phase. The GPS is accurate only within few metres and has sometimes difficulties on the forest roads, where trees block a significant part of the sky. The INS device used in this project was a military grade device, but was missing its original odometer. The unavailability of odometer signal resulted in problems with the device creeping. The creeping could be controlled by making intermittent stop to allow the INS to make a "zero update" (set the speed to zero and remove much of the position error). However, if this update was still in progress when the vehicle started moving again, the INS position data would often become useless. At that point, a new start up was required. Even though in the vehicle computer we had the odometry information available, we were unable to feed it into the INS.

In the demonstration the vehicle was able to follow the defined course. On the forest road the positioning was greatly improved by using the tree trunks as landmarks. Their positions had been recorded and on consequent passes, the vehicle could achieve greater path following precision.

In this second demonstration the user interface had also been upgraded to include a map interface (see Fig. 6). The map was actually an aerial image of the demonstration area and on top of it were drawn the available route segments the vehicle was able to follow. With the same view, the driver could plan the path including setting stops and different reference speeds for different parts of the path. The position of the vehicle was seen on the map and the video frame showed real time video. The driver could fine tune the autonomous path following by setting an offset the vehicle would take into account. The driver could also take over the control or stop the vehicle in case the vehicle was not performing as it was supposed to, but no such case occurred in the demonstration. Obstacle avoidance was demonstrated by placing objects on the path of the vehicle. The vehicle detected and avoided these objects by planning a path around them. The second demonstration was again successful by achieving the main goal of driving autonomously through a pre-defined course. The main source of problems and limitations with autonomous driving were the positioning issues.

5.3 Demo 3 - Unmanned mission scenario

The aim of the third demonstration was to demonstrate the capability of the whole UGV system to perform a complete mission. The final demonstration was held in October 2007. The area used was the same as in previous demos, but the exact location was changed to allow a better view of the events to the audience. Essentially the new content of the final demonstration was to put together all the new and all previously seen features of the unmanned vehicle system. As in the previous demo, a reconnaissance/surveillance mission was assigned using a separate command and control system. The first objective was to search a designated area for enemy activity using the cameras on board the vehicle. The second objective was to measure the level of radiation and test the presence of harmful chemical and biological aerosols using a dedicated NBC detector payload. The third

objective was to park the vehicle at a suitable location and use it as a remote observation platform using the ground surveillance radar fitted on the roof of the vehicle. To add interest for the audience, a number of different vehicles and soldiers on foot were acting as the enemy. Also, arrangements were made so that the NBC detector could detect chemicals and radiation and raise an alarm. This demonstration also introduced a payload operator, who was in charge of operating the observation camera, the NBC detector and the ground surveillance radar.

After receiving the mission orders, the driver plotted the path for the vehicle and sent it on its way. The vehicle followed the designated path using the autonomous path following function and cruise speed controller. The payload operator was using the camera to check for "enemy" presence. For the remote observation task, the vehicle was driven and parked at one edge of an open field. The "enemy" soldiers and vehicles would then cross the field and the payload operator would pick up them on the radar and camera.

In this demonstration we experienced the most notable demonstration setback as just before starting, the network card of the NBC device broke and with no replacement part available, communication with the device became impossible. The demonstration still followed the original script, but without the NBC alarms. Apart from that, the demonstration was a success as the mission was accomplished as planned.



Fig. 6. User interface of the UGV demonstrator. On the left the map view of the demo area and on the right the video frame of the driving camera. Information about the vehicle state can be seen on the bottom right corner.

5.4 Analysis of the communication delay

Accumulation of the delay in the communication chain was measured for benchmarking purposes to analyze the system performance and to be able to evaluate future communication solutions. The delay experienced by the operator is a critical aspect in teleoperation. The total delay experienced by the operator is the sum of delays from two sources: the forward-loop delay, which is the time that passes from the moment the operator gives a command until the moment the command is executed and feedback delay, which is the time that passes from the moment something happens at the remote site, until the moment the operator gets information about the event.

Different methods have been considered to overcome the problems associated with teleoperating with long delays, including raising the level of autonomy of the system being controlled and using a model of the real system at the operator side of the system. In some cases the response of the real system is predicted and the predicted state is visualized for the operator.

In the case of this project, the forward-loop delay can be further divided into processing delay within the remote control station, transmission delay and the processing and actuation delay in the vehicle. In the feedback channels (data and video use slightly different methods) there are also delays in processing, transmission and display of information.

To measure the performance of the teleoperation system and to identify the sources of largest delays, a measurement setup was arranged. The remote control station and vehicle brake lights were recorded with a single video camera so that the delay between operator brake pedal press and brake light illumination could be calculated from the recording. The camera records 25 fps so the delay calculated from the number of frames is accurate to ± 40 ms. In an effort to improve this, we measured several runs and averaged the results.

To measure the delay in the mechatronic system, a light emitting diode was connected to another I/O output and set to illuminate simultaneously with an electrical signal that causes the brake pedal to be pushed. Again, the lights were videotaped and delay calculated from the frames. The delay between the diode lighting up and the vehicle brake light doing the same is essentially the time it takes to accelerate and move the actuating motor enough to push the brake pedal. There are small delays associated with the electronics (e.g. H-bridge driving the motor, led lights up faster than a bulb), but these can be omitted in the time scale we are working in.

The delay in the video image was measured similarly. A person standing in the view of the vehicle cameras waved an arm and the video camera recorded the person and the remote control station display showing the person on screen. The delay was again calculated from the frames in the recording.

Total forward-loop delay from pushing the teleoperator's brake pedal until vehicle brake lights lit up averaged to 560 ms (see Fig. 7.). The delay in the mechatronic system was measured to be 224 ms on average. All processing delays proved insignificant. The longest delays seemed to be associated with the radio. It took an average of 665 ms, which seemed surprisingly long, but was verified to be correct. The video delay was measured with different image compression settings, but the differences in delays were not statistically significant. The video delay averaged to 340 ms for road camera and 550 ms for observation camera.

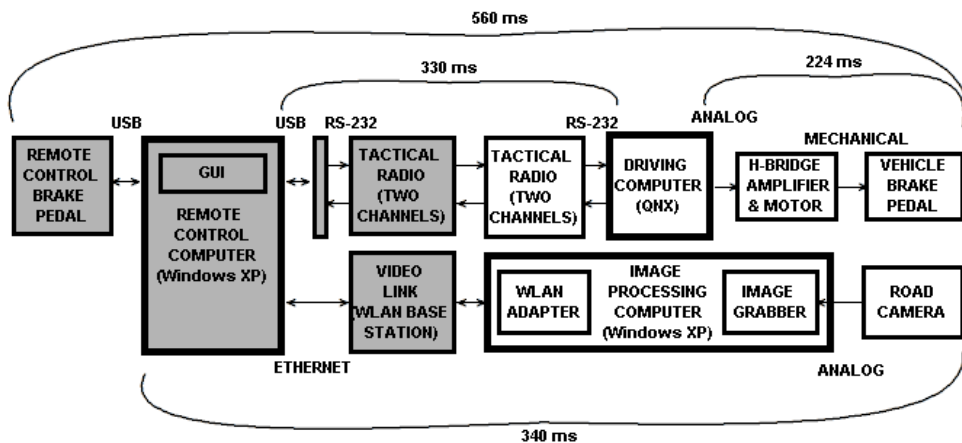

Fig. 7. Data flow and delays in teleoperation. The upper part depicts the forward-loop delay and the lower part the video delay of the road camera.

5.5 Teleoperation tests

In an effort to gain a better understanding of the requirements for an unmanned vehicle user interface, to somehow measure the quality of the current implementation and enable its further development, a separate project was launched. The aim was to find out what requirements there should be for the interface and how they could be measured. Three most important usability attributes out of Nielsen's total of five (Nielsen, 1993) were identified. They were low error rate, efficiency and memorability.

People involved in the development process of a system often adapt to using it and become blind to its problems and shortcomings. This is why "real" users were used to review our user interface. The test subjects were officers of the FDF chosen in an effort to find users that would match the potential real users of a UGV system. The test setup is shown in figure 8.

The user interface used in the experiment was essentially the same as in the final third demonstration. Much of the setting was also the same: the vehicle was driven from a tent mostly at the open field. The operator could see the vehicle at its starting position, but during the experiments it was driven so far and also to places where it could not be directly seen. The test subjects were driving the vehicle first assisted and after becoming comfortable with the controls, unassisted. They were also utilizing some of the automatic functions such as the cruise controller. They were asked to think aloud their thoughts during the experiment. The user interface, user actions and speech were recorded using a video camera and logging user actions by software. After the experiment the subjects were interviewed. In addition to user testing, formal evaluation without users (Lewis & Rieman, 1993) – also known as expert methods – such as cognitive walkthrough and usability heuristics were used.

Problem spots and ideas for improvement

The video images in the user interface are essential. The observation camera was found to provide better view of the terrain ahead. This is somewhat surprising since it is located higher and contours of the terrain are harder to see. The colors are the likely quality factor since the lower camera is a monochrome one. Some of the most significant problems and ideas for improvement were:

- It was difficult to understand which way the observation camera was pointing. A compass or preferably a 3D-arrow or vehicle should be overlaid to visualize the direction.
- The fixed camera's viewing angle was not wide enough to see the road while making sharp turns. Wider lens would improve this, but also introduce distortion, which is an additional burden for image processing in case the camera is used also for that.
- The vehicle traveling direction nor planned path could not be seen in the view. These should be overlaid to aid the driver to see where he should drive and where the vehicle is going. The steering wheel angle gives a rough idea, but to see the path in the image would provide additional help.
- Obstacles could be highlighted and/or distance coded. Judging the distance to an obstacle becomes harder with non-stereoscopic vision.
- The direction of the cameras and vehicle and projected path and speed of the vehicle would improve the map view. The map should (optionally) turn vehicle traveling direction up.
- Vehicle is often driven at same setting for long periods. A hand-operated throttle similar to tractors or airplanes would ease strain on foot.
- Emergency stop buttons were available both in software and as a small button on the wheel. A better option would be a separate big, fixed switch.
- Turning the observation camera was done by buttons on the wheel, but as the wheel was turned, it was difficult to see which way they worked. A separate controller would be better.
- The system has a number of modes to allow direct teleoperation, some automatic functions and autonomous driving. The current mode was displayed as big text and color, but this was unintuitive.
- The number of modes should be low to make a simple interface, but more modes would allow better control and freedom for the driver. Selecting the mode could be automatic, but the user should be kept aware of the mode currently in use. Even when the user specifically selects the mode, different modes are known to cause mode confusion, which is a known issue in aviation psychology (Bredereke & Lankenau, 2002) and also a significant problem area in the control of automatic systems.

The teleoperation tests showed that test subjects were able to learn to drive the vehicle in a relatively short time. They were generally comfortable operating it and said they were positively surprised of the general easiness of driving. On the other hand, as the user tests and expert methods revealed, the system and the user interface were still quite limited and there was much room for improvement. Even though our UGV project was not aiming to build a product, the usefulness of involving outside users in testing its user interface was

clear. In a bigger scope, the robustness and reliability of autonomous systems in unstructured environment still remains a challenge.



Fig. 8. Setup for the teleoperation tests. Observing researcher sitting on the left and test operator using the remote control devices on the right. The UGV starting the mission can be seen in the background.

6. Summary and conclusions

The presented UGV technology demonstrator was successfully instrumented using mainly affordable COTS components and thus represents a minimum realization able to realistically demonstrate capability potential with the given missions. The test tasks were related to tactical reconnaissance and surveillance and the UGV was able to cope with the predefined tasks largely autonomously, requiring operator support only with demanding decision making and in unexpected problem situations. Capability for task-oriented operation was enabled by the systems level solution that combines autonomous motion and task execution capabilities of the UGV, as well as the scalable level of autonomy in the HMI supporting the remote operator. Also, systems integration and information flow between the C4I system and the UGV remote control station was essential part of the whole system.

In the first phase of the UGV project, unmanned driving capability of the vehicle was achieved. It was noticed that a fairly good quality video image is needed for the teleoperation. This requires a lot from the communication link, not only range but also delay characteristics are important. In the UGV demonstrator case, the maximum distance was limited to approximately one kilometre by the WLAN connection at our test site. In our setup, the vehicle speed had no technical limitation but the judgment depending on the sensed delay was left completely for the teleoperator. Real environment is very seldom free

of obstacles and the speed has to be adjusted accordingly. The limiting factor for speed in teleoperation systems is the delay in the control loop, or time that it takes from a driver action until the consequence of the action can be seen in the feedback. Another observation made was that more feedback - an audio signal for example - from the vehicle would have been useful.

The second phase demonstrated more autonomous features of the vehicle. Autonomous driving capability was achieved and the HMI was developed especially for the mission execution. Positioning of the vehicle was accurate enough but it was discovered that the environmental model was clearly inadequate for reliable autonomous operation. Obstacle avoidance, for example, was not to be trusted since some obstacles remained unobserved. Therefore, the operator had to supervise the vehicle at all times, which is not convenient in the long run. More sensors should be added to the sensor system in order to enhance the environmental model of the UGV and situation awareness of the operator.

In the final demonstration the mission capability was demonstrated. A fictitious reconnaissance mission was assigned from the C4I system to the operator, who formulated the mission for the vehicle. Payload was teleoperated, other tasks were performed automatically under the supervision of and occasional correction by the operator.

Autonomous task execution with UGVs is still relatively new area of research and it is still in its infancy. Fully autonomous task execution, especially in hostile environment, is not yet - if ever will be - practical. There is a growing research interest (both civilian and military) in the higher level control of mobile robotics that deals with task execution and related HMIs to assist and supervise this capability. Therefore, scalable level of autonomy is needed to enable smooth task execution and seamless operator involvement.

At the same time, the development of navigation and positioning systems has gone a long way and it has been shown that those problems can be solved. As an example, there are already commercial devices and features which can be added to vehicles to improve the performance and situation awareness of the driver.

Although UGVs coping with dynamic environment have been under research and development only for the past few decades, the results of the development of subsystems are already visible. Nowadays, it is possible to set up a functional UGV system, relatively cost-effectively, by integrating commercial subsystems. In other words, one does not have to design and produce every single subsystem from scratch anymore. However, a system integrated from commercial components might be functional, but it is not in any way optimized or fit for military operations. To achieve reliability needed in field operations, a great deal of platform specific development and optimization is needed.

The most difficult problems within current UGV technology are qualitative environment sensing, context awareness and communications. Also, it is essential to observe humans from the vicinity of the UGV for safe operation. It can be estimated that the role of the driver in both commercial and military vehicles will be more of a supervisory one in the future. There will be fully autonomous vehicles for specific tasks and applications, but for most vehicles, the driver - either on or off the vehicle - will be in charge and take over the control when necessary.

7. Acknowledgements

Our research was funded by the Finnish Defence Forces' technology program and additionally by the Scientific Advisory Board for Defence. The authors also want to thank other project partners, especially Patria Group and VTT (Dr. Hannu Lehtinen, Dr. Ilkka Kauppi, Petri Kaarmila and Jarmo Prokkola).

8. References

- Armchair General online. (2004). Soviet Army (RKKKA) in World War II. [Online] Available at: <http://www.armchairgeneral.com/rkkaww2/weapons/tanks1.htm> [Accessed 29 April 2009]
- Bredereke, J. & Lankenau, A. (2002). A Rigorous View of Mode Confusion, *Proceedings of SafeComp 2002*, pp.19-31, ISBN 3-540-44157-3, Catania, Italy, September 2002, Springer Verlag
- Cage, D.W. (1995). UGV HISTORY 101: A Brief History of Unmanned Ground Vehicle (UGV) Development Efforts. *Unmanned Systems Magazine*, Special Issue on Unmanned Ground Vehicles. Vol. 13, No. 3, Summer 1995 Available at: <http://www.spawar.navy.mil/robots/pubs/ugvhist95-nopix.pdf> [Accessed 29 April 2009]
- DARPA (not dated). DARPA Urban Challenge. [Online] Available at: <http://www.darpa.mil/grandchallenge/index.asp> [Accessed 27 April 2009]
- ELROB (not dated). European Land-Robot Trial. [Online] Available at: <http://www.elrob.org/> [accessed 28 April 2009]
- GDRS (not dated). Autonomous Robotics Programs, Mobile Detection Assessment and Response System (MDARS). [Online] Available at: <http://www.gdrs.com/robotics/programs/program.asp?UniqueID=27> [Accessed 28 April 2009]
- IAI (not dated). Guardium - Autonomous Security Vehicle. [Online] Available at: <http://www.iai.co.il/17483-31663-en/default.aspx> [Accessed 5 May 2009]
- John Deere (2008). R-GATOR. A stand-alone autonomous vehicle and a rugged, versatile platform for tactical payloads. [Online] (updated September 2008) Available at: http://www.deere.com/en_US/contractsales/fedmilitarysales/media/pdf/rgator_08_3480.pdf [accessed 4 May 2009]
- Kairos Autonomi (not dated). Pronto4 Strap-on Autonomy System for Existing Vehicles or Vessels. [Online] Available at: http://www.kairosautonomi.com/pronto4_system.html [Accessed 4 May 2009]
- Kaleun, T. (not dated). Light demolition carrier "Goliath" (Sd.Kfz.302/303a/303b) [Online] Available at: <http://www.geocities.com/CapeCanaveral/Lab/1167/egoliath.html> [Accessed 29 April 2009]
- Lewis, C. & Rieman, J. (1993) Task-Centered User Interface Design: A practical introduction. Shareware, published by the authors. Available at <http://hcibib.org/tcuid/> [Accessed 26 April 2009]
- Lightoller, C.H. (1935). Titanic and other ships. [Online] Project Gutenberg of Australia (updated April 2005) Available at: <http://gutenberg.net.au/ebooks03/0301011h.html> [Accessed 28 April 2009]

- Lohmann, R.H.C. (2007) About Group Rapid Transit and Dual-Mode Applications [Online] Available at: http://www.2getthere.eu/media/apm07_paper_-_about_group_rapid_transit_and_dual-mode_applications.pdf [Accessed 29 April 2009]
- NASA (2009). NASA's Mars Exploration Program. [Online] (updated Mar 2009) Available at: <http://marsprogram.jpl.nasa.gov/missions/> [Accessed 29 April 2009]
- Neumann, G.P. (1921). *The German air force in the Great War*. Translated from German by J.E. Gurdon. Hodder and Stoughton limited, London. Available at: <http://www.archive.org/details/germanairforcein00gurduoft> [Accessed 28 April 2009]
- Nielsen, J. (1993). *Usability Engineering*. Academic Press. San Diego, CA. ISBN-13 978-0-12-518406-9
- NREC (not dated). Unmanned Vehicle Design. [Online] Available at: <http://www.rec.ri.cmu.edu/projects/unmanned/index.htm> [Accessed 4 May 2009]
- PATH (not dated). AVCSS Vehicle Demonstrations, Vehicle Control.[Online] Available at: <http://www.path.berkeley.edu/PATH/Research/demos> [Accessed 27 April 2009]
- Sandia (2008). Accident Response Mobile Manipulator System (ARMMS) [Online] (updated Jan 2008) Available at: <http://www.sandia.gov/isrc/ARMMS.html> [Accessed 26 April 2009]
- Sandvik (2008). Automine [Online] (updated Mar 2008) Available at: [http://www.miningandconstruction.sandvik.com/\(products-mine-automation-systems-Automine\)](http://www.miningandconstruction.sandvik.com/(products-mine-automation-systems-Automine)) [Accessed 4 May 2009]
- Schmidhuber, J. (2005). Prof. Schmidhuber's highlights of robot car history. (updated 2007) Available at: <http://www.idsia.ch/~juergen/robotcars.html> [Accessed 4 May 2009]
- Sheridan, T.B. (1992), *Telerobotics, Automation, and Human Supervisory Control*, The MIT Press. ISBN 0-262-19316-7, Cambridge, Massachusetts
- SPAWAR (2007a). Evolving Paradigms of Human-Robot Interaction [Poster]
- SPAWAR (2007b). Unmanned Systems Branch Honors WWII UAV Pioneer, In: *Robotics update*. Winter 2007 / Vol. 7, No. 2. [Online]. Available at: http://www.spawar.navy.mil/robots/newsletter/RoboticsUpdate_7_2.pdf [Accessed 26 April 2009]
- TeKes (2006). Kalmar Industries Oy Ab: The automatic port of Brisbane. [Online] (updated Apr 2007) Available at: http://www.tekes.fi/eng/success_stories/Menestystarina_tiedot.asp?id=4916 [Accessed 4 May 2009]
- UniBwM (not dated). Vorarbeiten UniBwM: Die Versuchsfahrzeuge VaMoRs und VaMP. [Online] Available at: <http://www.unibw.de/lrt13/tas/mitarb/prof/vamp.pdf?searchterm=VaMP> [Accessed 16 November 2008]
- U.S.Army (2008). Future Combat Systems. [Online] (updated May 2008) Available at: <https://www.fcs.army.mil/systems/index.html> [Accessed 4 May 2009]
- Wade, M. (2008). Lunokhod. [Online] Available at: <http://www.astronautix.com/craft/lunokhod.htm> [Accessed 29 April 2009]
- Washington Technology (2008). General Dynamics to build robot vehicles. [Online] (updated Feb 2008) Available at: <http://washingtontechnology.com/articles/2008/02/25/general-dynamics-to-build-robot-vehicles.aspx> [Accessed 29 April 2009]
- Velodyne (not dated). Velodyne High Definition Lidar. [Online] Available at: <http://www.velodyne.com/lidar> [Accessed 27 April 2009]



Mechatronic Systems Applications

Edited by Annalisa Milella Donato Di Paola and Grazia Cicirelli

ISBN 978-953-307-040-7

Hard cover, 352 pages

Publisher InTech

Published online 01, March, 2010

Published in print edition March, 2010

Mechatronics, the synergistic blend of mechanics, electronics, and computer science, has evolved over the past twenty five years, leading to a novel stage of engineering design. By integrating the best design practices with the most advanced technologies, mechatronics aims at realizing high-quality products, guaranteeing at the same time a substantial reduction of time and costs of manufacturing. Mechatronic systems are manifold and range from machine components, motion generators, and power producing machines to more complex devices, such as robotic systems and transportation vehicles. With its twenty chapters, which collect contributions from many researchers worldwide, this book provides an excellent survey of recent work in the field of mechatronics with applications in various fields, like robotics, medical and assistive technology, human-machine interaction, unmanned vehicles, manufacturing, and education. We would like to thank all the authors who have invested a great deal of time to write such interesting chapters, which we are sure will be valuable to the readers. Chapters 1 to 6 deal with applications of mechatronics for the development of robotic systems. Medical and assistive technologies and human-machine interaction systems are the topic of chapters 7 to 13. Chapters 14 and 15 concern mechatronic systems for autonomous vehicles. Chapters 16-19 deal with mechatronics in manufacturing contexts. Chapter 20 concludes the book, describing a method for the installation of mechatronics education in schools.

How to reference

In order to correctly reference this scholarly work, feel free to copy and paste the following:

Pekka Appelqvist, Jere Knuutila and Juhana Ahtiainen (2010). Mechatronics Design of an Unmanned Ground Vehicle for Military Applications, *Mechatronic Systems Applications*, Annalisa Milella Donato Di Paola and Grazia Cicirelli (Ed.), ISBN: 978-953-307-040-7, InTech, Available from:

<http://www.intechopen.com/books/mechatronic-systems-applications/mechatronics-design-of-an-unmanned-ground-vehicle-for-military-applications>

INTECH

open science | open minds

InTech Europe

University Campus STeP Ri
Slavka Krautzeka 83/A
51000 Rijeka, Croatia
Phone: +385 (51) 770 447

InTech China

Unit 405, Office Block, Hotel Equatorial Shanghai
No.65, Yan An Road (West), Shanghai, 200040, China
中国上海市延安西路65号上海国际贵都大饭店办公楼405单元
Phone: +86-21-62489820

Fax: +385 (51) 686 166
www.intechopen.com

Fax: +86-21-62489821

© 2010 The Author(s). Licensee IntechOpen. This chapter is distributed under the terms of the [Creative Commons Attribution-NonCommercial-ShareAlike-3.0 License](#), which permits use, distribution and reproduction for non-commercial purposes, provided the original is properly cited and derivative works building on this content are distributed under the same license.