

# Wind Farm Protection Systems: State of the Art and Challenges

Tamer A. Kawady, Naema M. Mansour and Abdel-Maksoud I. Taalab  
*Electrical Engineering Department, Minoufiya University  
Shebin El-Kom, Egypt*

## 1. Introduction

Owing to the rapid increase of the global population and their energy needs, traditional means to satisfy the burgeoning energy demands need careful reevaluation. Coupled with the uneven distribution of resources around the world, economic impacts of large-scale importation and the environmental impacts of continued dependence on nonrenewable fossil fuels, there is an imminent need to transfer, at least partly, the dependence on to renewable energy resources. Among these resources, wind electric conversion systems have emerged as the leader at the present time. According to the Global Wind Energy Council (GWEC) annual report, over 27 GW of new wind power generation capacity came on line worldwide in 2008 representing a 36% growth rate in the annual market, bringing the total global wind power capacity to over 120GW through the end of 2008 as shown in Fig. 1 [1]. This indicates that there is huge and growing global demand for emissions-free wind power, which can be installed quickly, virtually everywhere in the world.

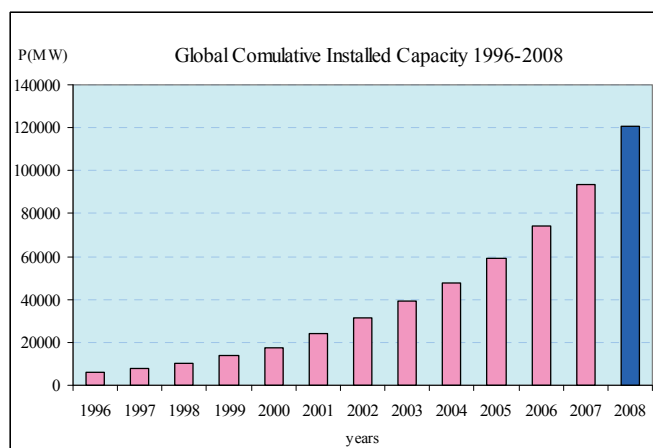

Fig. 1. Global cumulative installed capacity 1996-2008 (source GWEC annual report) [1].

Although, the renewable energy as a percentage of US electricity is only 3%, wind energy now contributes over 42% of all non-hydro renewable generation, up from 33% in 2007 as in Fig. 2. The U.S. Department of Energy's report, 20% Wind Energy by 2030: Increasing Wind Energy's Contribution to U.S. Electricity Supply, found that reaching a level of 20% wind energy by 2030 was feasible under one closely examined scenario [2]. In Europe, according to new European Wind Energy Association (EWEA) statistics released in early February, 2009, the wind penetration of the Europe Union (EU) power is accounted for 36%, or 8,484 MW, of new capacity, beating all other power technologies including gas, coal and nuclear power as shown in Fig. 2 [3]. The EU has agreed on legislation to realise 20% renewable energy by 2020, so to reach the 20% renewable energy target, the EU will need to increase the share of electricity from renewable energy sources from 16% in 2006 to at least 34% in 2020.

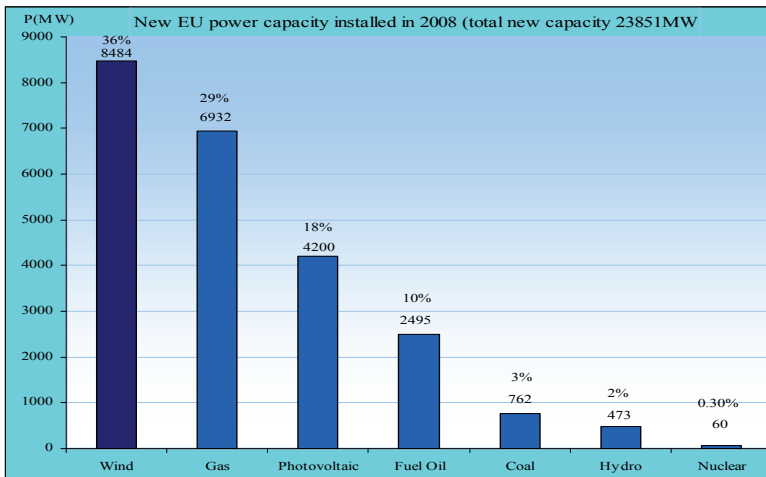

Fig. 2. New EU power capacity installed in 2008 (source EWEA annual report 2008) [2].

The impressive growth in the utilization of wind energy has consequently spawned active research activities in a wide variety of technical fields. Moreover, the increasingly penetration of wind energy into conventional power systems highlights several important issues such as reliability, security, stability, power quality, ... etc. Among these issues, providing wind farms with the proper protection is quite essential. The essential benefits from the dedicated protection functions are to avoid the possible local damage resulting from incident faults and minimize the impact of these abnormal conditions on other sound parts of the network. This consequently enhances the reliability and dependability of the overall grid performance. These terms such as continuity, reliability ...etc. have recently received much attention due to the new de-regulation policies and marketing liberalization. On the other hand, wind farms are characterized with some unique features during their normal and faulty operating conditions. Different factors participate usually into these conditions such as the distributed generation concept, the own behavior of the induction generator, varying wind speed, ... etc. Moreover, the economic perspective plays a major role as well. This consequently highlights different challenges regarding the behavior of their protection and control schemes. The primary objective of this chapter covers two basic

goals. The first goal concerns with describing the outlines of the basic wind farm protection systems that are usually utilized with modern wind farms nowadays. The basic protection zones including the wind farm area, wind farm collection system, wind farm interconnection system and the utility area are described. For each zone, the utilized protective elements are described. Their performance will be fully explored, since these relaying elements for wind farms, in particular, are sometimes characterized with different performance as compared with other ones used conventionally in power systems. The second goal is to emphasize the protection challenges concerning with the utilized protective elements that are usually employed with wind farms.

The outline of this chapter is as follows. The next section presents an overview of the occurred electrical faults in wind farms including their types, natures and statistical analysis. The configuration of the conventional protection systems for wind farms is outlined in section 3 covering the generators, local transformers, wiring circuitry and coupling point. Section 4 highlights the basic challenges of utilized protective elements in wind farms. Some different simulated illustrative examples are presented in section 5 based on a detailed modelling of Al-Zafarana wind farm in Egypt using both SFIG and DFIG generators. Recent trends for improving the protection performance are covered in section 6. Finally the resulted conclusions and the relevant references are provided in sections 7 and 8 respectively.

## 2. An Overview of Electrical Faults in Wind Farm Systems

The economic perspective plays a major role, in which the enormous cost pressures usually coerce the wind farm designers for economic causes to remarkably reduce the utilized protection schemes. As reported by Bauscke et al. in [4], different levels of damage were recorded resulting occasionally from the drawbacks of the associated protection system. As a result, wind farm providers still utilize simple and none-integrated protection methodologies [5], [6]. Different sources of failures are experienced for wind farms resulting in unwanted disconnections of some wind turbines for relatively large times for locating and maintaining these failures. These causes and their influences were statistically analyzed by Ribrant and Birtling [7] for the Swedish wind power plants as compared with their corresponding analysis in Germany and Finland respectively [8], [9]. As reported from Fig. 3(a), the failures in the electrical systems represent the largest share as compared with other types. The associated downtimes for these failures are ranked as shown in Fig. 3(b). This reveals the expected dangers of such electrical faults and consequently raises the importance of their relevant protective schemes. As concluded from Table 1, 2.38 failures per turbine were recorded yearly in Germany resulting in 62.6 hours of downtime per failure yearly as well. Moreover, those electrical system failures are ranked as the dominant failure causes. With the increasing of the of wind power penetration into power systems, these remarkable downtimes are not acceptable due to their influence on the overall system stability and continuity. This obviously raises the importance of providing wind power plants with the most appropriate protective schemes against such electrical abnormalities.

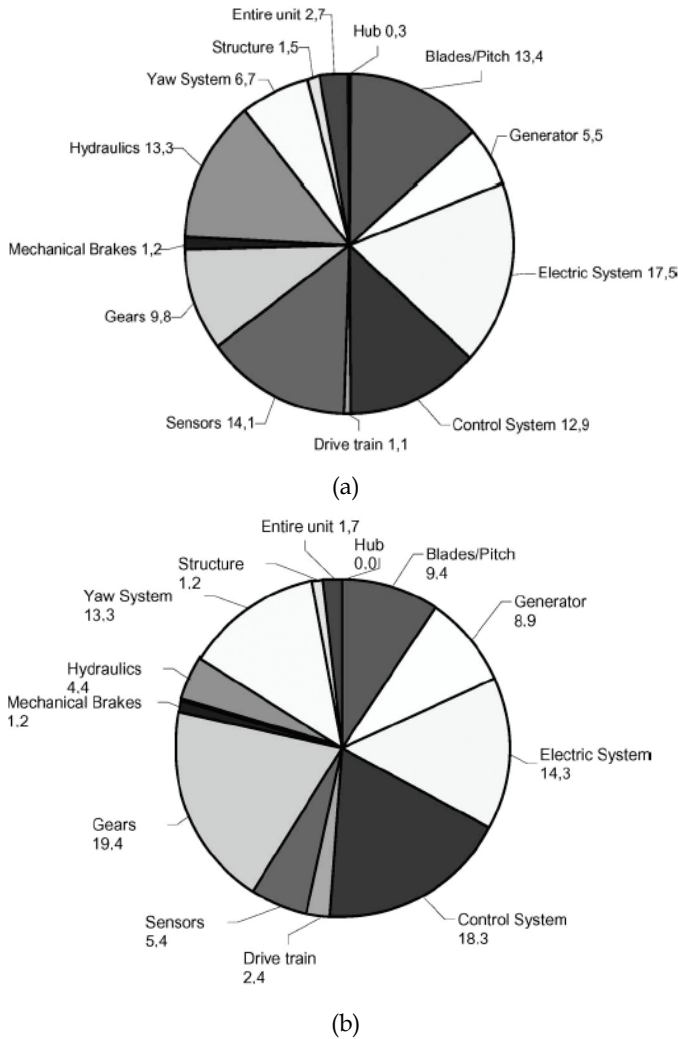

Fig. 3. Distribution of failures in the Swedish wind power plants (1997-2005) [7].

- (a) Distribution according to the failure type
- (b) Distribution according to the related downtimes

Country	Sweden	Finland	Germany
Average number of failures per turbine	0.402 times/year	1.38 times/year	2.38 times/year
Average downtime per failure	170 hours/year	172 hours/year	62.2 hours/year
Most failure causes	Electrical system	Hydraulics	Electrical systems
Longest downtime per failure	Drive train	Gears	Generators

Table 1. Statistical summary for the wind plants in Sweden, Finland and Germany.

Since, the increasingly penetration of wind energy into conventional power systems, the availability of the wind turbine, and reliability of the corresponding wind energy conversion systems should be increased. This spawned active research to carry out several investigations of failure statistics in the real field since the study of wind power turbine statistics gives knowledge of reliability performance. The investigation of the statistical studies is very essential for knowledge of the most frequently failures that may aid in the system maintenance planning and reconsidered the used protection schemes.

### 3. Common protective schemes for wind farms

#### 3.1 Basic Protection Functions

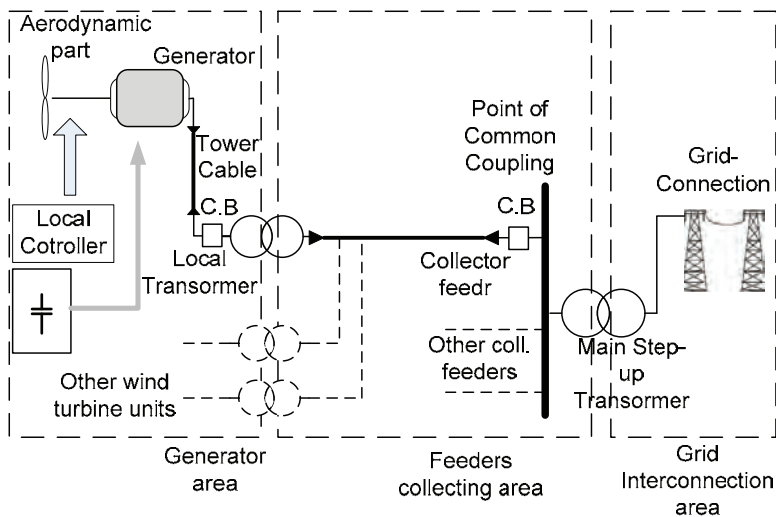

Fig. 4. Typical wind farm construction with its protection zones.

Fig. 4 shows a schematic diagram of a typical wind farm consisting of (n) units of wind turbines. Nowadays, modern wind farms include 20 to 150 units with typical size from 0.5 MW to 1.8 MW wind turbine generators. Larger sizes up to 3 to 5 MW are recently available in the market, in which they were successfully installed in some European countries. The typical generator's terminal voltage may range from 575 to 690 V with frequency of 60 Hz. The generator terminal voltage is stepped up to the Collector Bus system with typical voltage of 34.5 kV. The step up transformer is an oil cooled, pad mounted located at the base of the wind turbine unit. Sometimes, the step up transformer is mounted in the turbine nacelle. Certain considerations should be applied for avoiding the harmonic effects. The typical wind farm collector system consists of a 34.5 distribution substation collecting the output of the distributed wind turbine generators through the incoming feeders. Usually some reactive power compensation units are provided by a collection of switched capacitors. Finally, the collected power is transferred to the utility side via an interconnection step up transformer [6], [10].

The common type of the wind turbine generators that are commercially available nowadays are induction generator (IG), wound rotor synchronous generator (WRSG), and permanent magnet synchronous generator (PMSG). Due to the uncontrollable natural characteristic of wind speed, the induction generators IGs are suitable for driving the wind turbines. The two basic types of wind turbines used nowadays are fixed-speed wind turbine (FSWT) that equipped with squirrel cage IGs and variable-speed wind turbines (VSWT) equipped with doubly fed IG (DFIG). Squirrel-cage induction generators work normally within a limited wind speed range, which is one of their main drawbacks in comparison with variable-speed ones. Variable-speed wind turbines are mainly equipped with a doubly-fed induction generators (DFIG) with variable frequency excitation of the rotor circuit. The stator windings are connected directly to the AC grid whereas the rotor windings are coupled through a partial scale back-to-back converter as in Fig. 9. The main advantage of DFIG wind turbines is their ability to supply power at a constant voltage and frequency while variations of the rotor speed. The concept of DFIG for variable-speed wind turbine provides the possibility of controlling the active and reactive power, which is a significant advantage as regards grid integration.

The wind farm protection system is usually divided into different protection zones including the wind farm area, wind farm collection system, wind farm interconnection system and the utility area. First, the induction generator protection is typically accomplished via the generator controlling system covering some certain protection functions such as under/over voltage, under/over frequency, and generator winding temperature (RTDs). Whereas, the generator control system does not contribute for the interconnecting system or the utility zone. The generator step up transformer is usually protected with primary fuses. For those cases when the transformer is mounted in the nacelle, a circuit breaker is integrated with dedicated phase and ground time-overcurrent relays. The collector feeder protection is simplified considering it as a radial distribution feeder using overcurrent protection (50/51). A basic challenge arises due to the distributed generators connected together to the radial feeder in determining the minimum faulty zone. That is in order to keep the remaining sound parts of the farm supplying the power. On the other hand, the protection of the wind farm substation collector bus and main power transformer consists of multi-function numerical relay system including main transformer differential relay, transformer backup overcurrent relay, collector bus differential relay and breaker failure relay. Further details are available in the literatures. Considering the utility area, different protection functions may be used according to the voltage level and the considered protection topology. Direct transfer trip scheme, line differential relay, pilot protection, zones distance relaying, over/under voltage protection, over/under frequency protection, breaker failure protection, synchronous checking and backup overcurrent protection can be used [6], [10]. Taking into consideration that, the wind farm interconnection would be applied to MV distribution network or HV system, the coordination of utility relays and the wind farm will be therefore quite different. Communication system with dedicated SCADA is quite important for wind farm operation. Nowadays, the data from each wind generator control is transmitted via optic cables and spread the substations for general control and monitoring purposes. This provides an ideal situation for providing them with an integrated monitoring and protection system.

### 3.2 Rotor protection system

Historically grid codes allowed the wind turbines to be disconnected instantaneously with voltage sag below .8 per unit. In 2003, E.ON and VET (Germany) introduced the first FRT code requirements [11]. Later, other international wind energy associations introduced their similar codes as well. Generally speaking, the grid codes required that grid connected wind turbines should withstand with voltage dips on any or all phases in the transmission system as long as the voltage measured at the high-voltage terminals of the grid-connected transformer, or in other words at the common coupling point (CCP), remains above the predetermined level of the grid code [12]-[14]. Different benefits are expected to be gained with FRT capabilities including enhancing the system stability and fast restoration of system service if the fault is cleared during the allowable time. These capabilities can be achieved by an adapted control strategy.

The crowbar comprises of some certain thyristors that short-circuit the rotor winding and hence thereby limit the rotor voltage and provide an additional path for the fault current. When a disturbance is introduced, high currents are induced into the rotor circuitry from the stator side affecting the dc-link voltage as well. Then, the dc-link over-voltage protection will stop the rotor converter/inverter unit; meanwhile it turns on the crowbar control thyristor. Similarly, the crowbar can be triggered based on the occurring overcurrent through the rotor circuitry. The rotor is now connected to the crowbar and remains connected until the main circuit breaker disconnects the stator from the grid [13], [14]. After clearance of the fault the generator can be line-synchronized again and started in a normal operation mode.

The core of the crowbar operation was described by Akhmatov, Xiang, Holdsworth, Ekanyaki and Niiranen as reported in. Technically, two types of crowbar systems are known including passive and active ones. For passive ones, the crowbar consists of a diode bridge that rectifies the rotor phase currents and a single thyristor in series with a resistor  $R_{crow}$ . The thyristor is turned on when the DC link voltage  $U_{dc}$  reaches its maximum value or the rotor current reaches its limit value. Simultaneously, the rotor of the DFIG is disconnected from the rotor-side frequency converter and connected to the crowbar. The rotor remains connected to the crowbar until the main circuit breaker disconnects the stator from the network. When the grid fault is cleared, the rotor-side converter is restarted, and after synchronization, the stator of the DFIG is connected to the network [15]-[18].

In contrast to a conventional passive crowbar, the active crowbar is fully controllable by means of a semiconductor switch. This type of crowbar is able to cut the short-circuit rotor current whenever needed and thus the DFIG wind turbine is able to ride through a network disturbance. If either the rotor current or dc link voltage levels exceed their limits, the IGBTs of the rotor-side inverter are blocked and the active crowbar is turned on. The crowbar resistor voltage and dc link voltage are monitored during the operation of the crowbar. When both these voltages are low enough, the crowbar is turned off. After a short delay for the decay of the rotor currents, the rotor-side inverter is restarted and the reactive power is ramped up in order to support the grid.

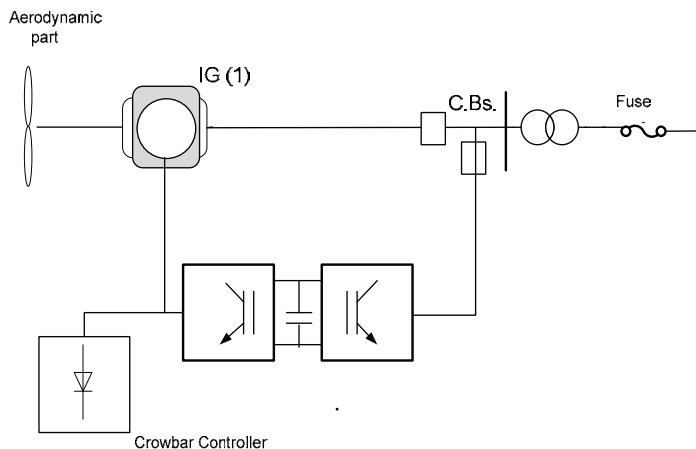

Fig. 5. Crowbar protection system for DFIG units

Practically, crowbar mechanisms raise some problems. The crowbar ignition leads to the loss of the generator controllability through the machine side converter (MSC), since the machine rotor is short-circuited through the crowbar resistors and the MSC is blocked. During this time slot the, generator acts as a common single fed induction generator and consumes reactive power, which is not desirable. Hence, utilizing crowbar mechanisms has recently replaced with employing DC chopper used to limit the DC voltage by short-circuiting the DC circuit through the chopper resistors. This was demonstrated in Fig. 6. Further information is available in the literatures [11].

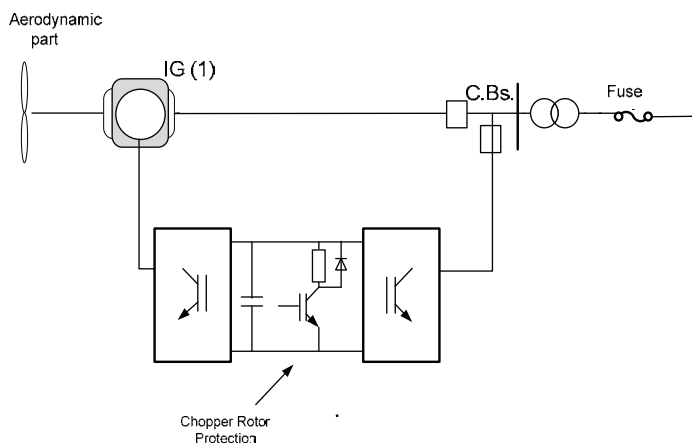

Fig. 6. Chopper rotor protection system for DFIG units



### 3.3 Wind turbine controller role

Typically, each turbine set is equipped with a multi-function numerical integrated controller unit. This controller provides different control actions regarding concerning with the generator system, power factor correction, yaw operation, hydraulic system, pitch mechanism, ..... etc. In addition to its control functions, it provides different protection functions such as,

- Over/Under voltage protective relays (27/59).
- Over/Under frequency protective relays (81O/U).
- Monitoring the electrical parameters (currents, voltages, power ... etc.) and disturbance recorders.
- Communication with the main control system
- Power flow control

The aforementioned controller unit interacts with the utilized protective elements with the generator set for providing the generator with the appropriate protection as possible. According to the manufacturer designs (or operators experience), the allowable setting for these protective elements are set. As example, some manufactures recommend to instantaneously trip the generator set for a 25% overvoltage conditions and with a 0.1 second for a 20% conditions. Also, a 0.2 second for tripping is recommended for over/under frequency conditions with  $\pm 2$  Hz frequency deviation and instantaneous tripping for  $\pm 3$  Hz frequency deviation or above.

### 3.4 Monitoring, Command, and Control Systems

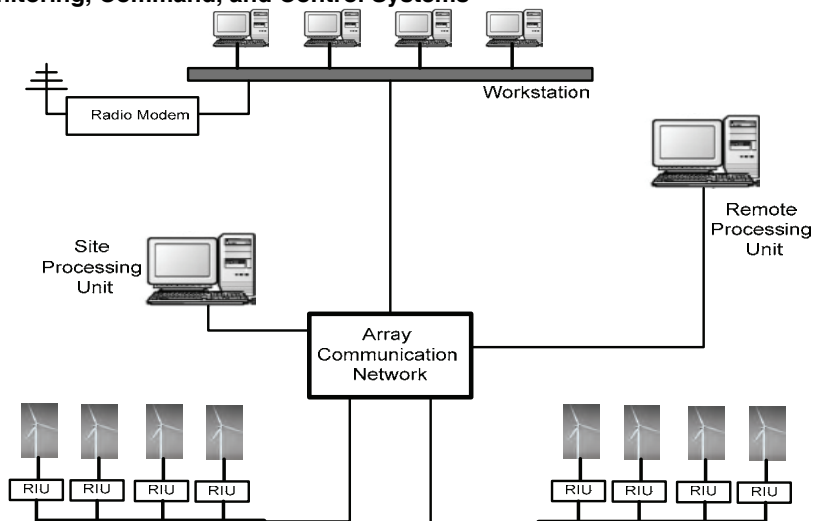

Fig. 7. Basic hierarchy of the utilized SCADA systems for wind farms.

Fig. 7 illustrates the basic outline of the utilized SCADA system that usually utilized with wind farms. Actually, the configuration of the communications system, along with the SCADA interfaces for large wind farm projects is complex depending on different factors including the utilized numerical protection and control devices hierarchies. The data from

each of the wind turbine control systems are collected with its local Remote Interface Unit (RIU) and send over a fiber optic cable installed in the same duct bank of the medium voltage collector feeder. The data is then transmitted to the main workstation for monitoring and control purposes [6]. The main workstation facilitates to monitor all environmental and electrical information at each turbine set and to control their operation using either automatic or manual process. Further spreading of the wind farm data is possible using radio or other communication channels. More sophisticated situations arise for off-shore farms in particular.

### **3.5 Protection of the local step-up transformer**

The local step-up transformer at each generator set is usually connected with Delta-Grounded Wye (or Grounded Wye-Grounded Wye) according to generator manufacturer's requirement. Current Limiting Fuses (CLFs) are commonly employed for protecting such transformer and its corresponding sub-connecting feeder for each induction generator set. This is mainly due to its reliability, simplicity and low cost. This economic perspective, on the other hand, is quite essential for wind farms, in particular, due to the massive numbers of such power system elements in large wind farms.

### **3.6 Collector feeder protection**

The collector feeder is simply considered as a radial distribution. It is usually protected using overcurrent protection (50/51) element. A basic challenge arises due to the distributed generators connected together to the radial feeder in determining the minimum faulty zone. That is in order to keep the remaining sound parts of the farm supplying the power. The interconnection transformer has usually a 3-winding configuration with a grounded Wye - grounded Wye connection. The tertiary winding is connected Delta. The Delta Tertiary is used to stabilize the neutrals of the transformer and provide zero sequence current to ground fault on both sides of the main transformer bank. If a Delta-Wye transformer is used for the main interconnecting transformer, a grounding transformer may be installed on the Delta side of the transformer to provide stabilization of the transformer primary neutral. The protection for the wind farm distribution substation consists of multifunction numerical systems including a main transformer differential relay, transformer Time-Overcurrent relay for the main transformer back-up protection, collector bus differential relay, distribution Time-Overcurrent relay, and breaker failure protection. It should be considered that, the wind farm interconnection would be applied to MV distribution network, HV system ... etc. Therefore, the coordination of utility relays and the wind farm will be quite different [19].

## **4. Basic protection challenges**

The essential benefits from the dedicated protection functions are to avoid the possible local damage resulting from incident faults and minimize the impact of these abnormal conditions on the other sound parts of the network. It enhances consequently the reliability and dependability of the overall grid performance. In spite of the obvious importance of the electrical protection of wind power plants, it surprisingly has not garnered a sufficient attention till present. The economic perspective plays a major role, in which the enormous cost pressures usually coerce the wind farm designers for economic causes to remarkably

reduce the utilized protection schemes. Different viewpoints arise as the causes for these problems as summarized below.

#### 4.1 Distribution system topology

The distribution connectivity nature, where infeed points are tapped sequentially from the same main feeder, may strongly influence the profile of the occurring fault. This is mainly due to the simultaneous feeding of the fault even with other unfaulted units.

#### 4.2 Protection system configuration

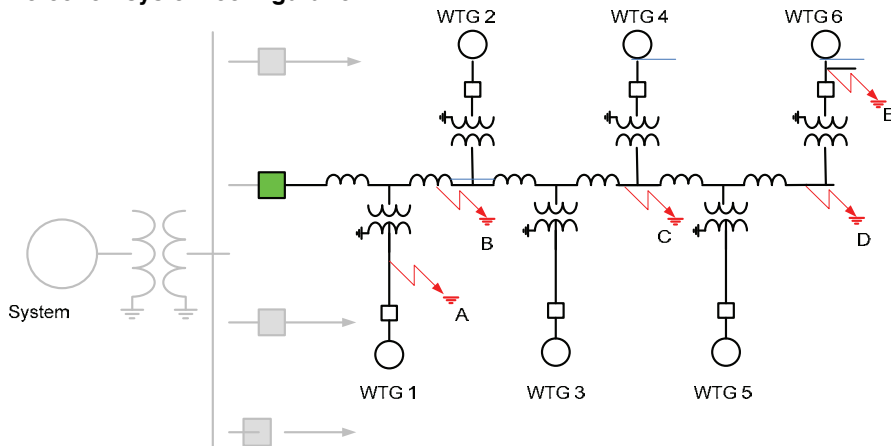

Fig. 8. Fault location effects on the protection of the collecting feeder

The economic factor and the distribution topology of the associated electrical networks result in utilizing simple protection methodologies with the local breaker/fuse combination for each generator-transformer unit. Then discriminating and locating those faults occurring at positions A, B, C, D and E (shown in Fig. 8) are usually lost. This results in disconnecting the whole collecting feeder for such faults.

#### 4.3 Distributed generation effects

Since the collector feeder can be considered as a radial distribution feeder connecting several wind generation units, it is expected to raise those similar protection problems of common distributed generations. Relaying mis-coordination and mal-operation are the most common ones.

#### 4.4 Control system requirements

Due to the impacts of the interconnection with the main power grid, some certain requirements such as "Fault Ride Through" are utilized to keep the system stability. The interaction among these operation modes and the employed relaying schemes should be considered to realize the proper and well coordinated protection performance.

#### 4.5 Dynamic behavior of the induction generator.

As known, induction machines have their own dynamic performance as compared with conventional synchronous ones. Moreover, the continuous wind speed variations and the interaction of the associated power electronics (for DFIG ones) collaborate together for providing the behavior of these machines during fault periods. More sophisticated and well coordinated relaying schemes should be provided to realize the most appropriate protection methodology for wind farm elements.

Insufficient protective elements, non-integrated control scenarios and improper coordination among protective and control strategies may lead to serious problems for large grid-connected wind farms. As example for these problems is the accident happening in North Germany on November 4, 2006. The UCTA interconnected grid was affected by a serious incident originating from the North German transmission grid that led to power supply disruption for more than 15 million households, splitting a synchronously connected network into three islands (two under-frequency and one over-frequency). After cascading overloads and tripping, two of three large separated systems (Western Island and North-Eastern Island) ended up with a significant amount of wind generation resources. Western Island (under-frequency state): During the incident, about 40% of the wind power units tripped. Moreover, 60% of the wind power units connected to the grid tripped just after the frequency drop (4,142 MW). Wind power units were automatically reconnected to the grid when the conditions of voltage and frequency were in the accepted range. North-Eastern Island (over-frequency state): Significant imbalance in this subsystem caused rapid frequency increase and triggered the necessary primary, standard and emergency control actions of tripping wind generation units sensitive to high frequency values. Tripping these units (estimated value of 6,200 MW) helped to decrease the frequency value during the first few seconds of disturbance. Further information for this event was available in [20]. The following section demonstrates different simulation examples for a typical 305 MW in Al-Zafarana, Egypt aiming to visualize the basic challenges of protective relays utilized for wind farms.

### 5. Simulated illustrative examples

#### 5.1 Modeling of Al-Zaafarana wind farm

A 305 MW wind farm was recently established in Al- Zaafarana (220 south east of Cairo, Egypt) and connected to the 220 kV Egyptian grid. This promising area (shown in Fig. 9) is distinctive with different superior features such as an average annual wind speed of 9.5 m/s, and its excellent geographical and environmental features. The farm was structured through six stages of 30, 33, 30, 47, 85 and 80 MW respectively. Except the latter two stages, other ones are with fixed speed and variable pitch operation. Currently, two further stages are being constructed adding extra 240 MW to the farm. The fourth and fifth stages were selected for simulation purposes representing typical examples for fixed and variable speed operations respectively. The fourth stage consists of 71 wind turbines (with a 660KW squirrel cage induction generator for each turbine) providing a total power of 47MW. The fifth stage consists of 100 wind turbines (with a 850 KW DFIG units for each turbine) providing a total power of 85MW. Fig. 10 (a) and (b) demonstrate the distribution of turbine units with 4 and seven collecting feeders for both stages respectively. Each wind turbine is

connected to a 690V/22 KV local step-up transformer and then integrated with the grid through 22/220 kV step-up transformers [21].



Fig. 9. Al-Zafarana wind farm location

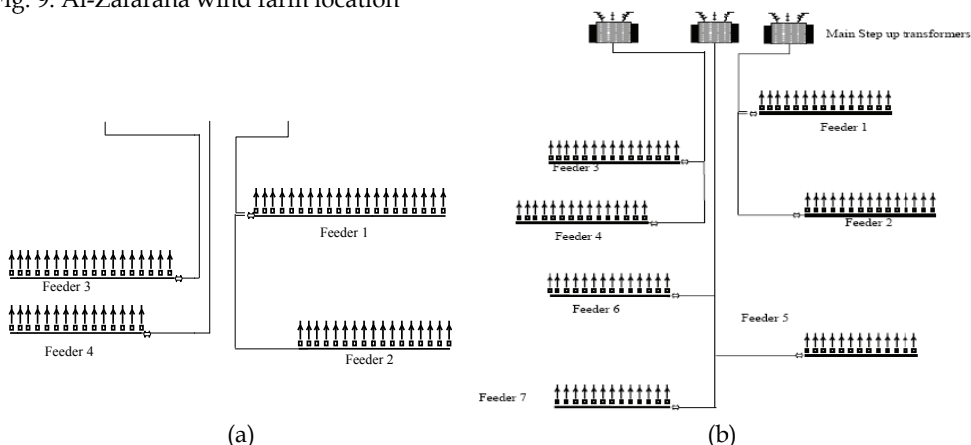

Fig. 10. Schematic of the fourth and fifth stages of Al-Zaafarana wind farm.

- (a) Fourth stage with 47 MW
- (b) Fifth stage with 85 MW

Fig. 11 (a) and (b) show the detailed schematic of each wind turbine unit constructed with the wind turbine and asynchronous machine blocks in MATLAB for both SFIG and DFIG respectively. Dedicated pitch control and converter/inverter blocks are implemented as shown in the aforementioned figures. The nominal wind speed was assigned to 9.5 m/sec “the annual average wind speed in its corresponding location”, whereas the “cut-in” wind speed was assigned to be 4.5 m/sec.

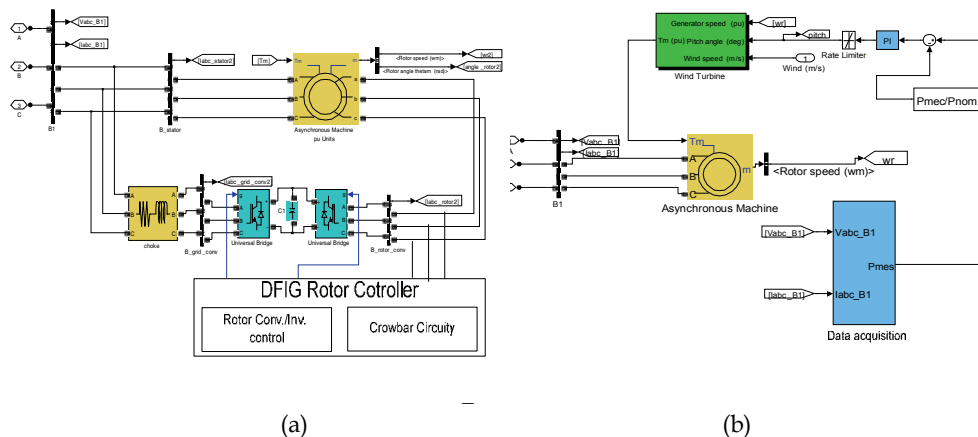

Fig. 11. Simulink-based diagram of Al-Zaafarana wind farm Generator modeling

- (a) DFIG machines  
(b) SFIG machines

The relatively large number of wind turbine units, in which each of them was constructed with different individual items “Turbine, generator, local transformer, feeding cable, ...” raises the obvious need for employing a reduced modeling for the selected stages. On the other hand, reduced model should be conditioned with the following restrictions:

- Model Accuracy for each individual power system element should be kept in its higher level.
- The essential concepts for distributed generation must be satisfied.
- Equivalence of currents for each individual unit as well as overall farm currents for both detailed and reduced model should be realized.
- Equivalence of the generated power for each individual unit as well as for the overall farm for both detailed and reduced model should be realized.
- Total power losses (due to connecting cables) should be considered.

For each stage, only one collecting feeder was constructed using detailed modeling for three units (the first, second and last units), whereas other units in the same feeder were lumped by a single equivalent unit. Other collecting feeders were also represented by their total equivalent power as well. For those lumped units, cable lengths were considered for keeping the total power losses equal to those resulted with the corresponding detailed model. The response of the reduced model was validated compared with the corresponding detailed one via different simulation examples for both faulty and non-faulty operating conditions. Details for the proposed modeling methodology were fully addressed in [22].

For either simulated wind farms stages, the behavior of both SFIGs and DFIGs were thoroughly investigated under various faulty and non-faulty operating conditions. The prepared simulation cases covered a wide variety of operating conditions including fault type, fault location, fault resistance and wind speed variations. These fault cases were prepared using the developed reduced model for both stages at different positions. For each

test case, three phase voltages and currents were recorded at various locations. This facilitated to explore the overall performance of the wind farm properly.

## 5.1 Performance of SFIG units

### 5.1.1 Ground faults

Ground fault is generally the most common fault type in electrical networks, whereas its behavior depends mainly on the fault position, soil resistivity, fault resistance and the applied grounding methodology. For a solid A-G fault at the generator terminals, the currents and the voltages at the generator terminals are illustrated in Fig. 12. No sensible fault current was remarked as a result of the ungrounded stator winding. The resulting overvoltage permitted the local controller to open the local C.B. within 100 ms.

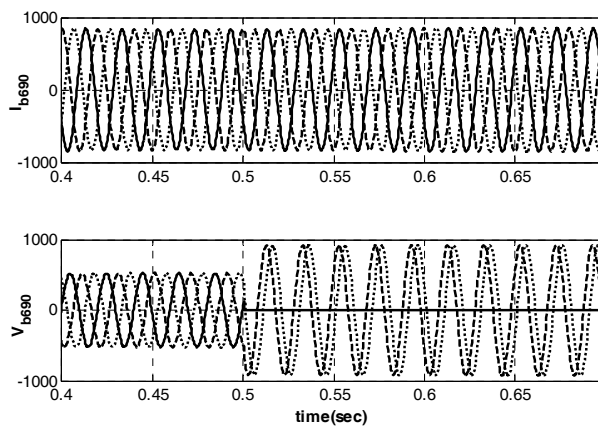

Fig. 12. Response to A-G fault at the generator terminals.

On the other hand, repeating the solid A-G fault before the fuse yielded the shown fault currents in Fig. 13 (a) and (b) fed from the associated local generator and other generating units (in addition to the main grid) respectively. Surprisingly, the fault current fed from the local generator was not sufficient to permit tripping of its local breaker (CB1) as remarked from Fig. 13 (a). On the other hand, the accumulated fault current from both the other generating units and the grid network is sufficient to melt the local fusing element as shown remarked from Fig. 13 (b). More complex situations were visualized with non-solid ground faults resulting from the occurred lower fault currents even with small fault resistance values. Also, repeating the fault before the local generator breaker (along the tower cable) is a challenge as well. Then, the need for more advanced protecting schemes for detecting such faults as well as for minimizing the tripped generation units is obvious.

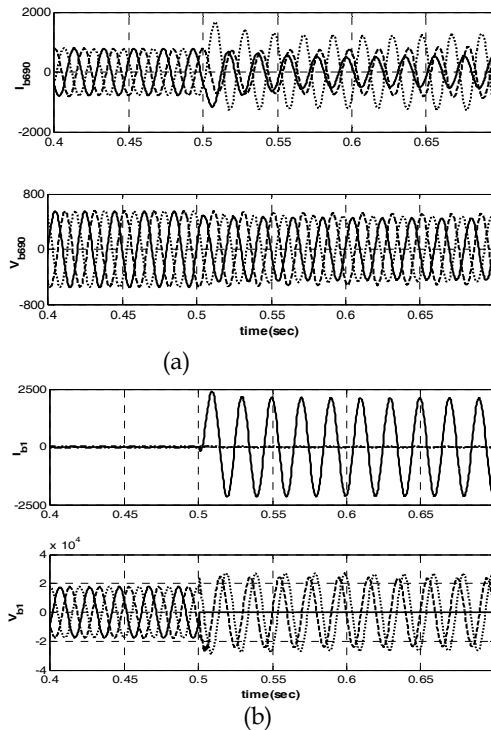

Fig. 13. Response to A-G fault before the fusing element.  
 (a) Voltages and currents at generator terminals.  
 (b) Voltages and currents at the medium voltage side

### 5.1.2 Phase faults

For A-B fault at the generator terminals, the resulting fault current exceeded the predetermined current setting for the associated generator breaker as well as the fuse of the faulted unit as described in Fig. 14 (a) and (b) for both fault feeding currents. The fault was accordingly tripped from both sides. Similarly to ground fault conditions, other connected turbines to the same collecting feeder participated also in feeding the fault. These units fed the fault individually with almost the same fault current level. However, their local fuses were not permitted to trip their branches. This was resulted from the obviously larger fault current passing through the own fusing element of the faulty unit (summation of other fault feeding currents), which accelerated its tripping action. Similar behavior was obtained with repeating the same fault condition (A-B fault) before the fuse element. It resulted from exceeding both counterparts of the fault current the setting boundaries of the associated breaker and the fuse.



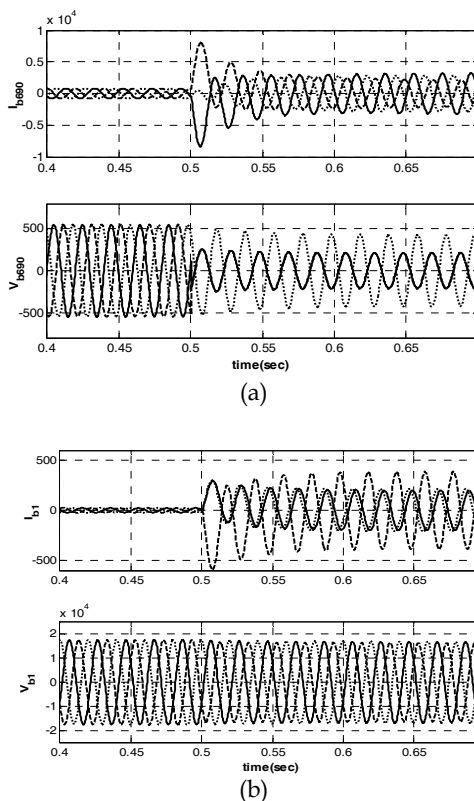

Fig. 14. Response to A-B fault at the generator terminals.  
 (a) Voltages and currents at the generator terminal.  
 (b) Voltages and currents at the medium voltage side.

With repeating the same fault condition after the fusing element, each participated wind generators fed almost the same fault current through its corresponding fuse. This resulted in completely losing the overall collecting feeder rather than tripping the faulty branch only. This typical distributed generation figure still represents a challenge for the utilized conventional protection elements. For a three phase fault on the generator terminals, Fig. 15 illustrated the response of the faulty unit demonstrating the associated voltages, currents and generated power. Fortunately, the three phase voltage and current quantities at the generator terminals were rapidly decreased to zero. The local controller of the associated generator disconnected its local breaker successfully due to the occurred undervoltage condition. Repeating the same fault before the fusing element yielded similar voltage and current profiles for the corresponding generator. Fortunately, the large fault current feeding from other generation units in addition to the grid network exceeded the fuse setting. On the other hand, other generating units sharing the same step up transformer had similar voltage and current profiles. This resulted in disconnecting these units by their undervoltage control, if the fuse associated with the faulty unit failed to operate.

Unfortunately, repeating the same fault condition after the fuse element resulted in disconnecting the whole collecting feeder. Also, other collecting feeders sharing the same step-up transformer had similar situation.

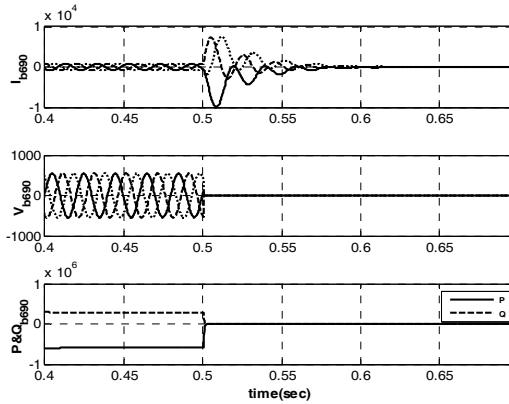

Fig. 15. Three phase fault at the generator terminals

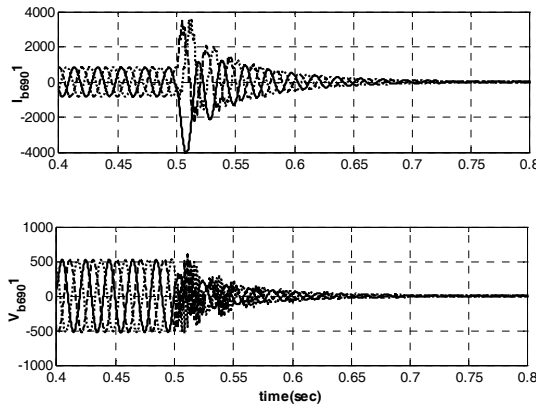

Fig. 16. Unit response to a three phase fault 5 km apart from the wind farm

**5.1.3 Grid faults**

In order to investigate the impact of network faults, a three phase fault was applied 5 km apart from the grid connection bus. The voltages and currents of all wind generation units were rapidly decreased to zero as shown in Fig. 16. Similarly, grid phase-phase faults resulted into under-voltage situations which may result in disconnecting all units as well. This of the generating units may strongly affect the system stability, particularly with large wind farms. Further details are available in [23], [24].

## 5.2 Performance evaluation of DFIG units

Depending on the developed model of the selected DFIG stage, the behavior of the modeled DFIG stage in conjunction with the related FRT mechanism was thoroughly investigated under various faulty and non-faulty operating conditions. For each case, voltage and current quantities for both stator and rotor circuitries were recorded as described in the following sub-sections.

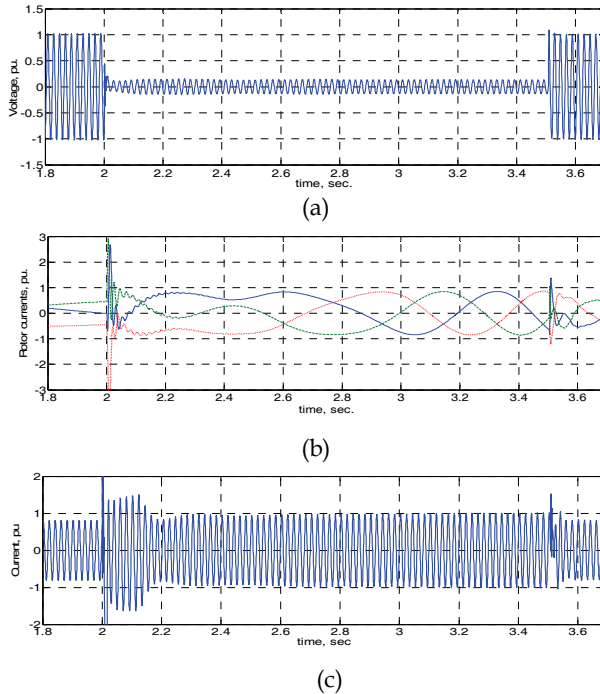

Fig. 17. Simulation response due to a solid 3-phase grid-fault without crowbar initialization.

- (a) Stator phase voltage, pu.
- (b) Rotor phase currents, pu.
- (c) Stator phase current, pu.

### 5.2.1 Grid faults

During grid faults, the occurred faults resulted in a sufficient drop of phase voltage so that the associated crowbar mechanism was initiated to protect the rotor windings from the excessive fault current. As illustrated in Fig. 17, both rotor and stator windings suffered from the increased currents resulted from a solid three phase grid fault occurring beyond the main collecting step up transformer. The corresponding crowbar scheme was inhibited during this test case. However, the occurred current levels were not sufficient for initiating the associated fuses or local breakers at each generating unit. Utilizing the crowbar scheme resulted in rapidly decreasing the rotor currents to zero as described in Fig. 18. As soon as the crowbar scheme was initiated as the machine reacted exactly as a SFIG one. Hence, the

stator currents we decreased to zero as remarked in Fig. 18 (b). Consequently the local protection at each generator set (fuses and local breakers) was blocked.

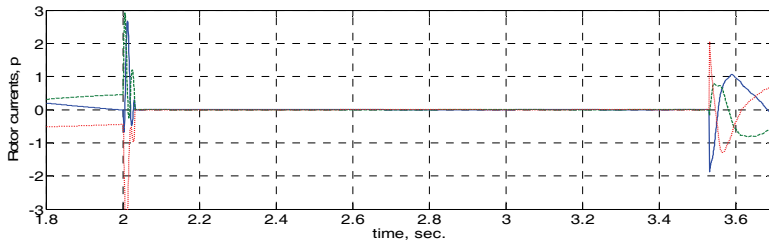

(a)

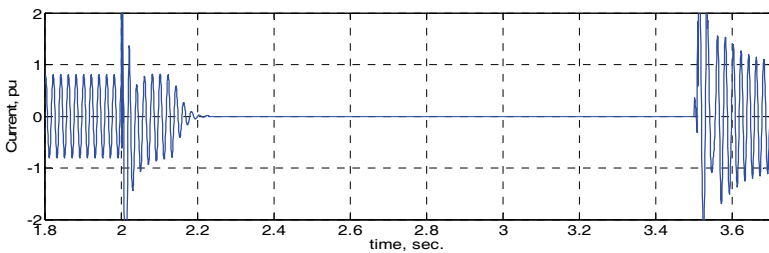

(b)

Fig. 18. Simulation response due to a solid 3-phase grid-fault with crowbar initialization.

- (a) Rotor phase current, pu.
- (b) Stator phase current, pu.

### 5.2.2 Wind farm faults

The DFIG response for a 2-phase solid fault beyond the local step-up transformer and the fusing element was investigated in Fig. 19. As remarked from the results, the occurred voltage drop initiated the crowbar mechanism. As noted from Fig. 19(c), the resulted stator fault current was not enough to initialize the utilized fuse element. At non-solid faults usually the fault current decreases due to an increased fault resistance. These faults should be considered for evaluating the behavior of the DFIG machines equipped with FRT mechanisms. When a fault resistance is inserted into the fault current path, the decrease of the fault current is accomplished with a decrease of the occurring voltage drop at the generator terminals. Consequently, the FRT mechanism may incorrectly be initiated for faults occurring inside the wind farm. This results in inhibiting the operation of the related overcurrent protection due to the reduced fault current. This resulted in inhibiting the operation of the associated fusing element. These situations of network faults were demonstrated well in [22].

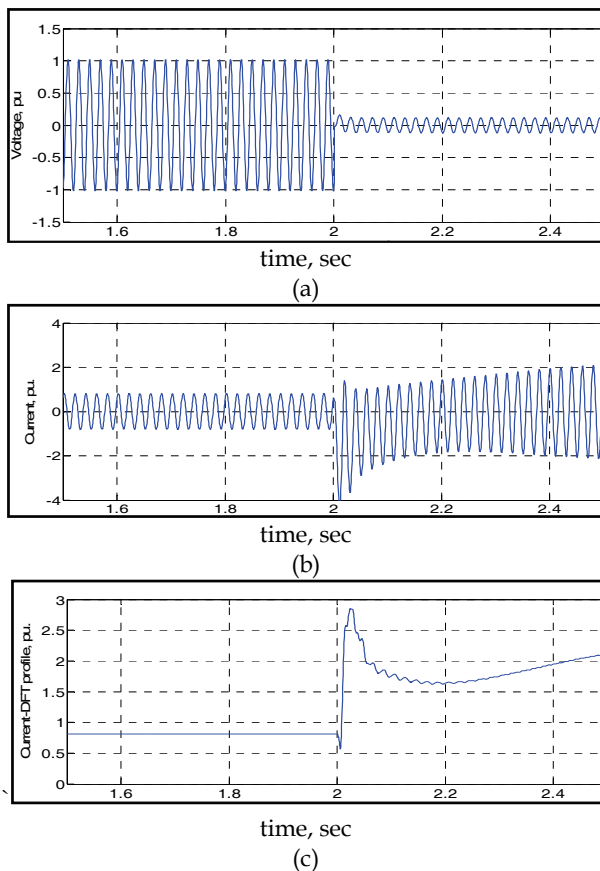

Fig. 19. Simulation response due to a solid 2-phase fault beyond the local transformer.

- (a) Stator phase voltage, pu.
- (b) Stator phase current, pu.
- (c) Stator phase current peak profile with DFT

## 6 Trends for improving wind farm protection systems

Due to the own behavior of induction generators as well as the specific topology of distributed generation concept for wind farms, employing CLFs for protecting the local transformer for each generating set was characterized with some certain shortcomings. Three different suggestions are proposed to eliminate the aforementioned protection problems described as follows.

### 6.1 Redesigning the distribution network

Different configurations of connecting wind turbine units were typically employed including Radial design, Single sided-ring design and Double sided-ring design, ... etc as described in the literatures. All of them are characterized with conventional distributed

generation profile. This consequently leads those un-faulty wind generators sharing the same collecting feeder to participate with the faulty unit for supplying the fault current. Larger portions of wind turbine units may be redundantly disconnected. Redesigning this wiring connectivity may eliminate the associated problems with the conventional distribution network topology.

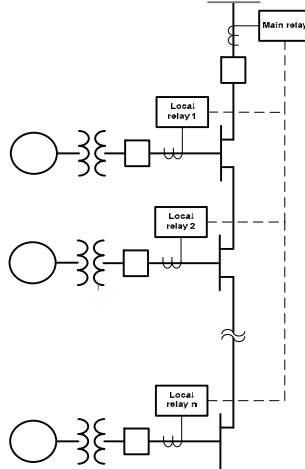

Fig. 20. Proposed communication-based relaying employment

## 6.2 Employments more protective elements

Utilizing more protective elements may represent solutions for all highlighted problems. As example, directional elements may eliminate the effects of distributed generator effects remarkably. Compromising between the economic prospective and the aimed performance is essential for realizing a practical and acceptable behavior.

## 6.3 Integrated protection with Enhanced communication employment

The proper employment of communication facilities in conjunction with the more sophisticated and integrated protective schemes may impressively eliminate the aforementioned problems. As described in Fig. 20, each of the local relays at each generator unit coordinates its response simultaneously with other generating units as well as wit the main protective element at the collecting bus. Fault location computation as well as the final tripping decision are then decided upon the status of these received signals. Depending on the existed communication links utilized with the used SCADA system of existed wind farms facilitates these steps.

## 7. Conclusions

This chapter emphasized the basic outline of the common configuration of protective relays that are usually utilized with modern wind energy conversion systems. Electrical faults occurring into the different zones of wind farms were described. Accordingly, different problems arise with the simple and non-integrated protection schemes that are usually

utilized with wind farms. The associated challenges of those protective elements were discussed and their relevant problems were visualized. Among these problems, unwanted disconnection of wind generation units, rather than disconnecting the faulty unit only, is not acceptable. This negatively impacts the continuity and the stability of the overall system. Some simulation examples were presented for demonstration purposes. These simulations were developed based on a real 305MW wind farm in Alzafarana-Egypt including both SFIG and DFIG configurations. For DFIGs, in particular, utilizing crowbar mechanisms may affect the behavior of conventional overcurrent protection elements against network faults occurring into the local connecting circuitry of the wind farm. The study emphasized the need for enhancing the existed protection schemes for wind farms to realize better power system performance as well as minimize the possible damages resulting from the fault occurrence. Intelligent techniques, enhancing the existed protection schemes for wind farms, redesigning the wind farm wiring topology and integrated protection schemes may play definite roles towards eliminating these problems.

## 8. References

- [1] Global Wind Energy Council (GWEC), "Global Wind Energy 2008 Report", <http://www.gwec.net>.
- [2] American Wind Energy Association, "Annual Wind Industry Report, 2008", <http://www.awea.org>.
- [3] European Wind Energy Association (EWEA), "EWEA ANNUAL REPORT 2008", <http://www.ewea.org>.
- [4] Stefan Bauschke<sup>1</sup>, Clemens Obkircher, Georg Achleitner, Lothar Fickert and Manfred Sakulin, "Improved Protection system for electrical components in wind energy plants", 15th International Conference on Power System Protection, PSP '2006, Bled-Slovenia, 6-8 Sept. 2006.
- [5] R. Ramakumar, N. Butler, A. Rodriguez and S. Venkata, "Economic aspects of advanced energy technologies", Proceedings of the IEEE, Volume 81, Issue 3, March 1993, pp. 318 - 332.
- [6] D. Hornak, N. Chau, "Green power - wind generated protection and control considerations", Protective Relay Engineers, 2004 57th Annual Conference for 30 Mar-1 Apr 2004, pp. 110 - 131.
- [7] Johan Ribrant and Lina Margareta Bertling, "Survey of Failures in Wind Power Systems With Focus on Swedish Wind Power Plants During 1997-2005", IEEE TRANSACTIONS ON ENERGY CONVERSION, VOL. 22, NO. 1, MARCH 2007.
- [8] H. Holttinen, T. Lakso, and M. Marjaniemi. (2005, Dec. 18) Tuulivoiman Tuotantotilastot Vuosiraportti, "Performance of wind power plants", annual report). 2000-2005, VTT, Espoo, Finland, [Online]. Available: <http://www.vtt.fi> (2005-12-18).
- [9] M. Durstewitz (Ed.), "Windenergie report Deutschland 2004-2005", Institut fuer Solare Energieversorgungstechnik (ISET), Kassel, Germany, N. E. Carlstedt, private communication, Nov. 2005.
- [10] S. Musunuri, "Protection requirements for a large scale wind park", Protective Relay Engineers Conference, 2009-30-03 to 02-04, 2009, pp. 478 - 491.
- [11] Erlich, W. Winter, A. Dittrich, "Advanced Grid Requirements for the Integration of Wind Turbines into the German Transmission System", IEEE General Meeting, GM2006.

- [12] Andreas Dittrich Alexander Stoev, "Comparison of fault ride-through strategies for wind turbines with DFIM generators", Power Electronics and Applications, 2005 European Conference on, Dresden, Germany.
- [13] V. Akhmatov, "Analysis of Dynamic Behaviour of Electric Power System with Large Amount of Wind Power", PhD Thesis, Electric Power Engineering, Orsted DTU Technical University of Denmark, April 2003, Denmark.
- [14] Niiranen, J. 2004. "Voltage Dip Ride Through of Doubly-Fed Generator Equipped with Active Crowbar", Nordic Wind Power Conference, 1-2 March 2004, Chalmers University of Technology, Göteborg, Sweden.
- [15] Niiranen, J. 2005. "Experiences on Voltage Dip Ride through Factory Testing of Synchronous and Doubly Fed Generator Drives", Proceedings of 11th European Conference on Power Electronics and Applications. Dresden, Germany, 11-14 September 2005.
- [16] Anca D. Hansen and Gabriele Michalke, "Fault ride-through capability of DFIG wind turbines", Renewable Energy, Elsevier, Vol. 32 (2007), pp. 1594-1610
- [17] Niiranen, J. 2006. "About the Active and Reactive Power Measurements in Unsymmetrical Voltage Dip Ride Through Testing", Nordic Wind Power Conference, 22-23 May 2006, Espoo, Finland.
- [18] Xiang, D., Ran, L., Tavner, P.J., Bumby, J.R. 2004. "Control of a Doubly-fed Induction Generator to Ride-through a Grid Fault", Proceedings of ICEM 2004, Cracow, Poland, 5-8 September 2004.
- [19] S. Haslam, P. Crossley and N. Jenkins, "Design and evaluation of a wind farm protection relay", Generation, Transmission and Distribution, IEE Proceedings, Volume 146, Issue 1, Jan. 1999, pp. 37 - 44.
- [20] Union for the Co-ordination of Transmission of Electricity (UCTE), "FINAL REPORT - SYSTEM DISTURBANCE ON 4 NOVEMBER 2006", UCTE, Brussels - Belgium, [www.ucte.org](http://www.ucte.org).
- [21] Tamer A. Kawady, Naema Mansour, Aly Osheiba, Abdel-Maksoud Taalab and Rama Ramakumar, "Modeling and Simulation Aspects of Wind Farms for Protection Applications", 40th ANNIVERSARY FRONTIERS OF POWER CONFERENCE October 29-30, 2007, Stillwater, Oklahoma, USA
- [22] Tamer Kawady, "An Interactive Simulation of Grid-Connected DFIG Units for Protective Relaying Studies", IEEE PES/IAS Sustainable Alternative Energy Conference-2009, Valencia, Spain, 28-30 Sept., 2009.
- [23] Tamer A. Kawady, Naema Mansour, Abdel-Maksoud Taalab, "Performance Evaluation of Conventional Protection Systems for Wind Farms" IEEE/PES General Meeting, GM-2008, Pittsburgh, 20-24 July, 2008.
- [24] Tamer A. kawady, Naema Mansour and Abd El-Maksoud I. Taalab, "Evaluating the Role of Current Limiting Fuses for Wind Farm Protection Applications", IEEE-PES General Meeting-2009, Calgary, Canada, 26-30 July, 2009.





## **Distributed Generation**

Edited by D N Gaonkar

ISBN 978-953-307-046-9

Hard cover, 406 pages

**Publisher** InTech

**Published online** 01, February, 2010

**Published in print edition** February, 2010

In the recent years the electrical power utilities have undergone rapid restructuring process worldwide. Indeed, with deregulation, advancement in technologies and concern about the environmental impacts, competition is particularly fostered in the generation side, thus allowing increased interconnection of generating units to the utility networks. These generating sources are called distributed generators (DG) and defined as the plant which is directly connected to distribution network and is not centrally planned and dispatched. These are also called embedded or dispersed generation units. The rating of the DG systems can vary between few kW to as high as 100 MW. Various new types of distributed generator systems, such as microturbines and fuel cells in addition to the more traditional solar and wind power are creating significant new opportunities for the integration of diverse DG systems to the utility. Interconnection of these generators will offer a number of benefits such as improved reliability, power quality, efficiency, alleviation of system constraints along with the environmental benefits. Unlike centralized power plants, the DG units are directly connected to the distribution system; most often at the customer end. The existing distribution networks are designed and operated in radial configuration with unidirectional power flow from centralized generating station to customers. The increase in interconnection of DG to utility networks can lead to reverse power flow violating fundamental assumption in their design. This creates complexity in operation and control of existing distribution networks and offers many technical challenges for successful introduction of DG systems. Some of the technical issues are islanding of DG, voltage regulation, protection and stability of the network. Some of the solutions to these problems include designing standard interface control for individual DG systems by taking care of their diverse characteristics, finding new ways to/or install and control these DG systems and finding new design for distribution system. DG has much potential to improve distribution system performance. The use of DG strongly contributes to a clean, reliable and cost effective energy for future. This book deals with several aspects of the DG systems such as benefits, issues, technology interconnected operation, performance studies, planning and design. Several authors have contributed to this book aiming to benefit students, researchers, academics, policy makers and professionals. We are indebted to all the people who either directly or indirectly contributed towards the publication of this book.

### **How to reference**

In order to correctly reference this scholarly work, feel free to copy and paste the following:

Tamer A. Kawady, Naema M. Mansour and Abdel-Maksoud I. Taalab (2010). Wind Farm Protection Systems: State of the Art and Challenges, Distributed Generation, D N Gaonkar (Ed.), ISBN: 978-953-307-046-9, InTech, Available from: <http://www.intechopen.com/books/distributed-generation/wind-farm-protection-systems-state-of-the-art-and-challenges>

# INTECH

open science | open minds

## **InTech Europe**

University Campus STeP Ri  
Slavka Krautzeka 83/A  
51000 Rijeka, Croatia  
Phone: +385 (51) 770 447  
Fax: +385 (51) 686 166  
[www.intechopen.com](http://www.intechopen.com)

## **InTech China**

Unit 405, Office Block, Hotel Equatorial Shanghai  
No.65, Yan An Road (West), Shanghai, 200040, China  
中国上海市延安西路65号上海国际贵都大饭店办公楼405单元  
Phone: +86-21-62489820  
Fax: +86-21-62489821

© 2010 The Author(s). Licensee IntechOpen. This chapter is distributed under the terms of the [Creative Commons Attribution-NonCommercial-ShareAlike-3.0 License](#), which permits use, distribution and reproduction for non-commercial purposes, provided the original is properly cited and derivative works building on this content are distributed under the same license.