

# We are IntechOpen, the world's leading publisher of Open Access books Built by scientists, for scientists

7,000

Open access books available

186,000

International authors and editors

200M

Downloads

Our authors are among the

154

Countries delivered to

TOP 1%

most cited scientists

12.2%

Contributors from top 500 universities



WEB OF SCIENCE™

Selection of our books indexed in the Book Citation Index  
in Web of Science™ Core Collection (BKCI)

Interested in publishing with us?  
Contact [book.department@intechopen.com](mailto:book.department@intechopen.com)

Numbers displayed above are based on latest data collected.  
For more information visit [www.intechopen.com](http://www.intechopen.com)



# Biomechanical Constraints in the Design of Robotic Systems for Tremor Suppression

Juan-Manuel Belda-Lois, Álvaro Page, José-María Baydal-Bertomeu,  
Rakel Poveda, Ricard Barberà  
*Instituto de Biomecánica de Valencia*  
(Spain)

## 1. Introduction

The *Movement Disorder Society* defines tremor as an involuntary rhythmic oscillation of a body part (Deuschl et al. 1998). This definition excludes other movement disorders with a less cyclic character such as chorea or ataxia. Tremor is the most frequent movement disorder in clinical practice with an estimated prevalence between 3-4% of the population over 50 (Manto et al. 2004).

Everybody has some tremor component, usually invisible for the naked eye, called *physiological tremor*. However, there are other forms of pathological tremor that can be very disabling, and often a cause of social exclusion (Rocon et al. 2004). There are many pathologies that can cause pathological tremor, among others Essential Tremor, Parkinson Disease, brain trauma or multiple sclerosis.

Common treatments of tremor are pharmacological and surgical. Pharmacological treatments depend on the specific pathology that causes tremor. For instance *Parkinson disease tremor* is treated with L-dopa, and common treatments for *Essential Tremor* are  $\beta$ -blockers (Deuschl et al. 1998). Surgical classical treatment for tremor is thalamic thermocoagulation (Deuschl et al. 2000). However from mid 90's Deep Brain Stimulation (DBS) is preferred to thermocoagulation (Deuschl et al. 2000).

Despite these therapies, there are still an important number of people with pathological tremor resistant to the common treatments (Deuschl et al. 1998). Thus, other alternatives are of interest to help people suffering from different kinds of pathological tremor. Many of these alternatives focus on removing the consequences of tremor rather than its origins. Among others the following approaches can be mentioned:

(a) Removing the tremor from a tremorous signal (Riviere & Thakor, 1996; Gonzalez et al. 2000) (b) Design of assistive devices based in dampers (such as the NeaterEater® or the MouseTrap®) (c) Design of robotics systems to suppress tremor.

This chapter focuses the attention on the design of robotics systems to suppress tremor. First of all, we will introduce different strategies to suppress tremor using robotic approaches, then we will show the biomechanical and ergonomics issues to take into consideration in the design of these robotic systems, finally we will introduce a set of guidelines to take into account in the design of robotics systems for tremor suppression.

## 2. Robotic systems to suppress tremor

Robotic systems allow mechanical tremor suppression while preserving the component of voluntary movement. This approach has been attempted previously by several authors considering different strategies, and using different robotic configurations.

### 2.1 Methodological introduction

In this chapter we will consider the mechanical system of a body segment with a robotic system attached to it from the perspective of dynamic systems theory. Given a simple mechanical system such as the one in figure 1, we can express the relationship between force and displacement in the form of a differential equation that includes the components of inertia ( $M$ ), stiffness ( $K$ ) and viscosity ( $c$ ) (1)

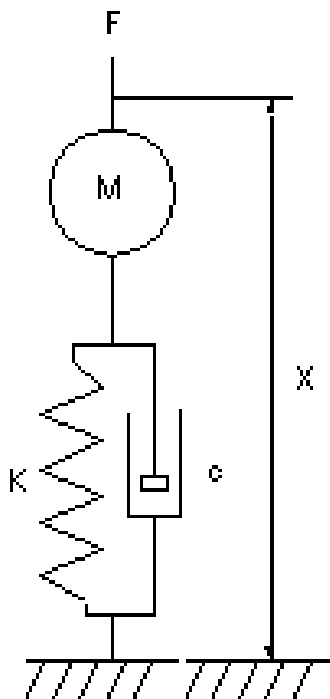

Fig. 1. Simple mechanical system to exemplify the relationship between force ( $F$ ) and displacement ( $\Delta X$ ) depending on the mechanical characteristics of the system.

$$F(t) = M \cdot \frac{\partial^2(\Delta x)}{\partial t^2} + c \cdot \frac{\partial(\Delta x)}{\partial t} + K \cdot \Delta x \quad (1)$$

Using the Laplace transform (2) we can change a differential equation such as (1) into an expression dependent on the operator  $s$  (3), and this kind of transformation allows to obtain expressions in which we can separate the physical characteristics of the system from the inputs and outputs (4). We can refer to these physical characteristics as *dynamic stiffness* (5) in the sense that is an expression of the complex relationship between the force applied and the position of the system.

$$L[f(t)] = F(s) = \int f(t)e^{-st} dt \quad (2)$$

$$F = M \cdot s^2 x + c \cdot sx + Kx \quad (3)$$

$$F = (M \cdot s^2 + c \cdot s + k)x \quad (4)$$

$$F = B(s) \cdot x \quad (5)$$

Besides, the use of the Laplace transformation has two extra benefits: a) it allows a relationship between an input signal (i.e. force) and an output signal (i.e. displacement) in a mathematical expression known as *transfer function*. b) it allows the identification of the mechanical system from its frequency response.

## 2.2 Strategies for tremor suppression

One obvious way to suppress tremor consists in damping the tremor component: adding viscosity to a joint makes the joint speed dependent. Thus, since a tremor movement is faster than common voluntary movements, the addition of damping should attenuate tremor. This approach has been tested through the use of dampers (Kotovsky & Rosen, 1998) or through the use of actuators based on magneto-rheological fluids (MRFs) (Loureiro et al. 2006).

From a wider perspective, adding viscosity to a joint changes the dynamic stiffness of the joint. But we can change dynamic stiffness by not only adding viscosity but also adding stiffness and inertia.

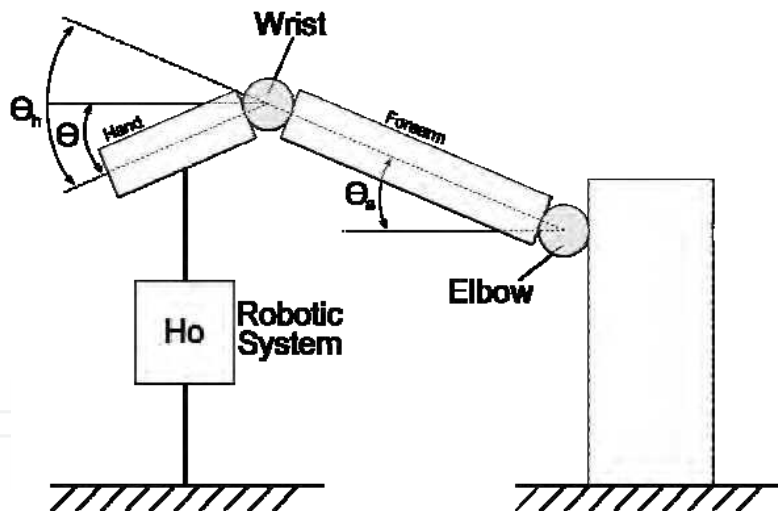

Fig. 2. Simplified diagram of grounded robotic system for tremor suppression.

Pledge et al. (2000), suggested the use of changes in the dynamic stiffness in order to attenuate tremor. Adding dynamic stiffness the overall bandwidth of the system can be changed, if the band of tremor is let out of the band of the overall system (human joint and robotic system) then the tremor should attenuate. This is the approach shown in (6), where  $B_a$  is the dynamic stiffness of the body system and  $B_o$  is the dynamic stiffness of the robotic system.

$$\theta(s) = \frac{1}{B_a + B_o} \cdot T(s) \quad (6)$$

Another feasible strategy consists in the implementation of a filter in a mechanical system. This has been one of the approaches of Rocon et al. (2005). The main idea of these authors was to track the frequency of tremor using the Weighted Linear Fourier Transform suggested by Riviere & Thakor (1996) and designing a zero-lag notch filter tuned to remove the tremor frequency component.

### 2.3 Grounded robotic systems

Grounded systems are those which create a mechanical linkage from a body segment to the ground or a fixed external system such as a desktop or a wheelchair. Figure 2 shows a simplified diagram of a grounded robot attached to the hand. For the sake of simplicity we have assumed a 2D model of the arm with only two joints the wrist and the elbow.

A system of these characteristics can efficiently suppress the tremor at the level of the hand. We can simplify the behaviour of the overall system to the diagram blocks of figure 3. We are considering that an input torque at the wrist joint of  $T_w$ ,  $H_o$  is the dynamic response of the robotic system (i.e. the transfer function), and  $B_e$  and  $B_w$  are respectively the dynamic stiffness of elbow and wrist joints.

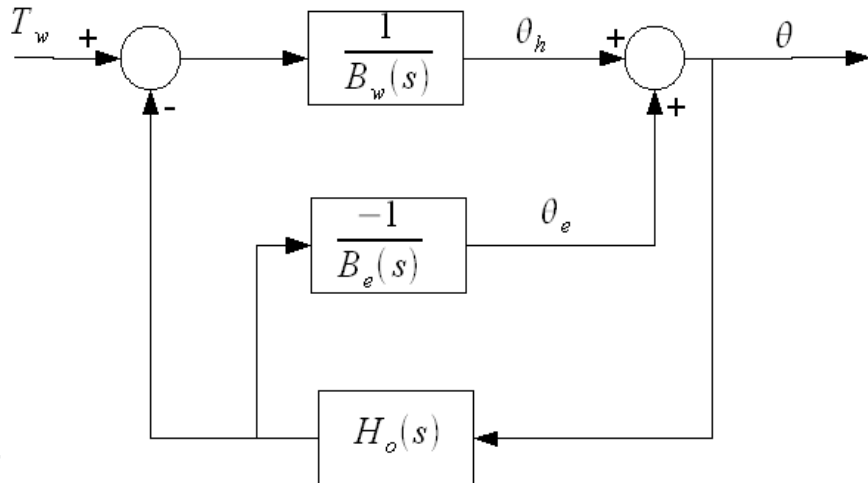

Fig. 3. Linearised model of the grounded robotic system shown in figure 2.

(7) is the expression of the overall movement of the hand according to figure 3. As it can be observed in (7) the response of the robotic system can modify the response of the hand.

$$\theta(s) = \frac{B_e}{B_w \cdot B_e + B_w \cdot H_o + B_e \cdot H_o} \cdot T_w(s) \quad (7)$$

However, due to the mechanical coupling introduced by the robotic system, a component of tremor will appear at elbow level such as shown in (8).

$$\theta_e(s) = \frac{-H_o}{B_w \cdot B_e + B_w \cdot H_o + B_e \cdot H_o} \cdot T_w(s) \quad (8)$$

In other words, keeping the tip of the hand steady with a grounded system will introduce a tremor component in the proximal joints. This component of tremor can be potentially dangerous when users perform movements oriented to his/her body such as eating or dressing.

If we considered an strategy based on the addition of dynamic stiffness instead of a generic suppressing strategy represented by a transfer function, we can compare (7) with the approximation of tremor suppression through impedance control suggested by Pledgie et al. (2000) which is shown in (6). At first sight both expressions are very different, but we can rearrange the terms of (7) as shown in (9), and substitute the response of the system, a generic transfer function, represented by  $H_o$ , for a dynamic stiffness represented by  $B_o$ .

$$\theta(s) = \frac{1}{B_w + \left(1 + \frac{B_w}{B_e}\right) B_o} \cdot T_w(s) \quad (9)$$

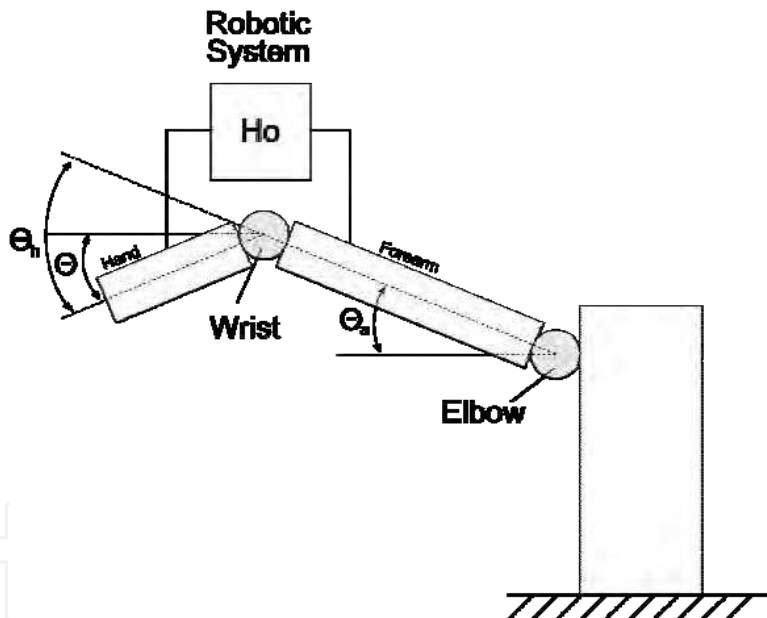

Fig. 4. Simplified diagram of a wearable robotic system for tremor suppression attached to the wrist joint.

But, according to Acosta et al. (2000) the dynamic stiffness of the arm should be considered as a whole due to the coupling of body structures and in particular to the existence of biarticular muscles. This hypothesis provides consistency to the approach of Pledgie et al. (2000) who identify the overall response of the arm as a generic linear second order system. Therefore, if frequency response of the arm is unitary, the dynamic stiffness of different joints can only differ, approximately, in the gain. Consequently, we can simplify further (9)

to (10), where  $K$  is a positive real number representing the relationship of stiffness of wrist and elbow joints.

$$\theta(s) = \frac{1}{B_w + K \cdot B_o} \cdot T_w(s) \quad (10)$$

As it can be seen, (10) is very similar to (6), and therefore the approximation of Pledgie et al. (2000) can be considered as a special case of the approach shown.

#### 2.4 Exoskeletons and wearable systems

The principles of exoskeletons are very different from grounded robotic systems. figure 4, shows a simplified diagram of exoskeleton to suppress tremor at the wrist joint. As it can be inferred from the figure, in this case there are not mechanical couplings (other than inertial coupling characteristics) able to transmit tremor from distal to proximal joints.

However, this approximation has two main drawbacks: firstly the system doesn't have control over the global position of the hand, just in the movement performed by the joint under control, (in the case of figure 4 the wrist angle), and secondly the system is unable to compensate tremor coming from other joints.

The block diagram for this approximation is much simpler (figure 5).

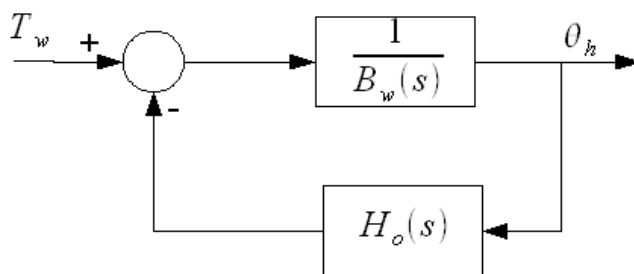

Fig. 5. Linearised model of the exoskeleton system.

Consequently the expression of the position of the hand with respect to the forearm is also simpler (11).

$$\theta_h = \frac{1}{B_w + H_o} \cdot T_w \quad (11)$$

Comparing (11) with (6) we can see that both expressions are identical, therefore the same type of tremor suppressing strategy is possible in this configuration.

### 3. Biomechanical requirements

In the last point we have considered how different strategies and approximations can be effective for tremor suppression. However, in all the development, we have considered ideal conditions in relation to the compatibility between the robotic system and the body segments. Human body segments impose their own constraints to the system and these constraints must be kept into account in order to construct useful devices able to suppress tremor.

One of the key factors when designing these systems is the management of the contact between the body and the system. The systems attached to the body require the

transmission of the loads to the skeletal system, but this transmission is only possible through the layers of soft tissues between the device and the skeleton.

Common orthotic practice has developed procedures for load transmission based mainly on safety and comfort issues. However, many common orthotic procedures are not applicable in the design of systems to suppress tremor because they are successful only in static or quasi-static conditions, but tremor is a pure dynamic effect and therefore requires other approaches.

### 3.1 Contact pressures

The transmission of loads from the systems to the skeleton produces contact pressure that can compromise safety and comfort.

Regarding safety, the usual guideline is avoiding pressures above the ischaemia level (the level at which the capillary vessels are not able to conduct blood compromising the tissue). This level has been estimated in 30 mmHg (Landis, 1930).

The relation between pressures and comfort is much more complicated. Touch receptors are sensitive to the deformation of the layers of tissue where they are located (Dandekar et al. 2003), therefore the perception of pressure is indirect: pressure deforms tissues and this deformation is sensed by skin receptors. Besides, the type, density and distribution of skin receptors varies significantly depending on the part of the body implied. Finally, the skin receptors have a dynamic response to the excitation (receptor adaptation). This dynamic response makes the pressure perception dependent on the dynamics of the process of applying pressure.

In orthotic practice the main guideline is reducing the contact pressure as much as possible increasing the contact surface between the system and the body, and reducing the risk of injury for maintained high pressures.

However, this guideline couldn't be appropriate from the point of view of comfort. According to Goonetilleke (1998) there exists an optimal surface to distribute a load and this value is a balance between pressure and number of touch receptors excited, also known as spatial summation theory (Goonetilleke, 1998). Furthermore, in the case of system for tremor suppression, as we will see later, the use of big supports to distribute the load worsen the performance of the system, consequently some kind of increase of contact pressure is needed in comparison with conventional orthoses.

To assess the tolerance of pressure of different parts of the body some authors made indentations to the point where the user feels pain or discomfort (Byström et al. 1995). However, the results of these experiments should be considered as a general indication of discomfort threshold since they depend on dynamics, shape and area of application.

### 3.1 Shear forces

Shear forces are together with pressure, the most important cause of skin injuries. Besides, compliance of skin in the shear plane is higher than in normal plane and this can cause loss of alignment in actuators which have an action line parallel to the body segment.

### 3.2 Kinematic compatibility

Body joints never act as pure hinge or ball joints, the geometry of body joints is usually very complex and can differ substantially depending on the person. On the other hand, robotics are commonly composed of inferior pair joints. Therefore, when we place a robotic system acting parallel to a body segment there are loss of alignments between the robotic system joint and body joint Instant Helical Axis (IHA). This loss of alignment is partially



compensated for the flexibility of body soft tissues and partially is transmitted as loads to the structures of the joint, and this can ultimately lead to an injury.

These injuries are relevant in powerful joints which manage an important amount of load such as the knee. In these cases the design of a mechanism able to follow-up as close as possible the body joint IHA is very important.

### 3.3 Protection of body structures

When applying loads to a body segment it is important to be careful with some structures in order to avoid discomfort, pain or the risk of injuries: Superficial vessels and nerves and bone prominences. Besides, we should keep free the area close to the joints.

### 3.4 Dynamic stiffness in the contact

In point 2, we have considered ideal contact conditions between the robotic system and the body segment. However, these conditions determine the overall performance of the system.

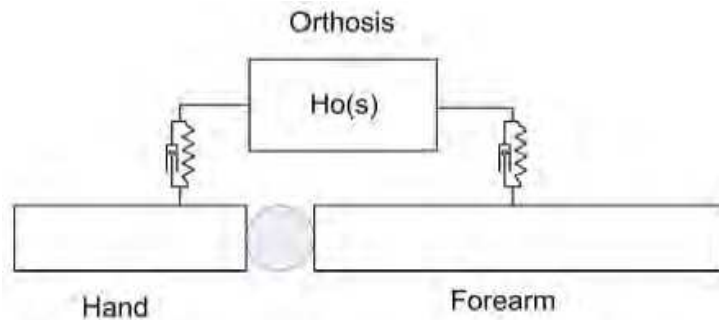

Fig. 6. Simplified view of a robotic system considering the dynamic stiffness in the contact.

If we consider the dynamic stiffness between the system and the body when we model the response of the system (figure 6), and we assume that the effect of the system is to apply a certain amount of dynamic stiffness ( $B_o$ ), then the overall equivalent stiffness of the system is (12). The dynamical stiffness of the contact points between the robotic system and the body segments, as well as the dynamical stiffness of the actuator are all in serial mode and consequently the overall dynamical stiffness has been reduced.

$$B_t = \frac{B_{s1} \cdot B_{s2} \cdot B_o}{B_{s1} \cdot B_{s2} + B_{s1} \cdot B_o + B_{s2} \cdot B_o} \quad (12)$$

If we consider that dynamic stiffness in both body segments is the same and we neglect the viscous component, then we can simplify (12) into (13) where  $K$  is the stiffness of the soft tissues under the contact of the system.

$$B_t = \frac{\frac{K}{2} \cdot B_o}{\frac{K}{2} + B_o} \quad (13)$$

To understand how the contact conditions can affect the performance of a robotic system for tremor suppression the response of an effective system and a stiffness in the contact of

$0.47\text{N/m}$  can be considered. As it can be seen in figure 7, the dynamic response of the system has changed considerably. If we consider the contact conditions, even for a well designed system we can lose all the attenuation in the frequency of pathological tremor (4 Hz) due to the stiffness of soft tissue. Thus the system is no longer capable of suppressing tremor due to the conditions of the contact.

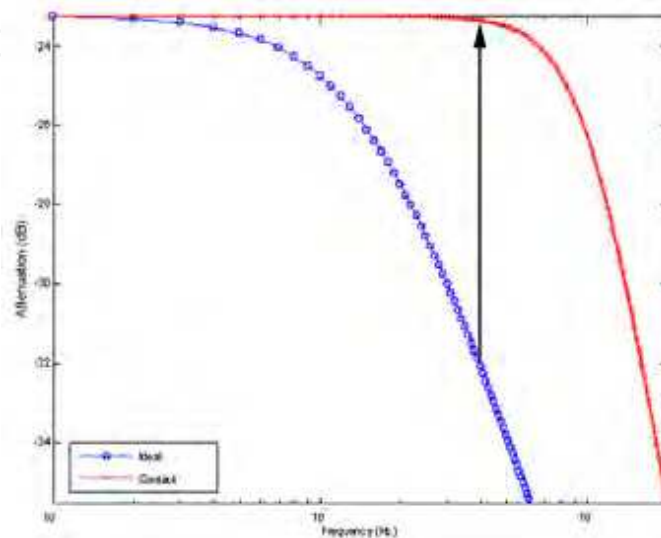

Fig. 7. Effect of the contact. The curve with circles is the response of the system considering an ideal contact between the system and the body segment. The curve with crosses is the response of the system considering the stiffness of the soft tissues. The arrow shows the loss of attenuation at 4 Hz (typical frequency of many pathological tremors) when stiffness of the contact is considered.

If we are able to increase the stiffness of the contact by a factor of 10 (overall stiffness  $4.7\text{N/m}$ ), the response of the system (figure 8) will come closer to the ideal behaviour. The system is able to suppress tremor.

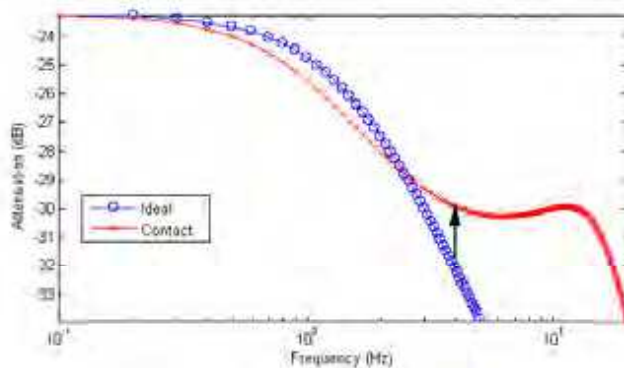

Fig. 8. The effect of increasing the stiffness in the contact. The arrow represents the loss of attenuation at 4 Hz when we consider the stiffness of the contact.

Moreover, the stiffness in the shear plane is considerably lower than in the normal plane. Thus, the response of the system will be worse in the shear plane.

In addition, the loss of alignment between the body segment and the orthosis can also produce a reduction of effectiveness. The stiffness of the soft tissues can produce this loss of alignment (figure 9). In the figure 9(a), the gap between the support system and the body segment is a representation of the contact of stiffness. When the segment corresponding to the hand moves, the orthosis does not act due to the loss of alignment between the fixation and the hand –Fig. 9(b)–

#### 4. Design principles

All the above considerations imply restrictions in the design of robotic systems for tremor suppression. We have summarised these constraints in three design principles:

- a) Length restriction
- b) Increase of contact pressure
- c) Alignments with body segments

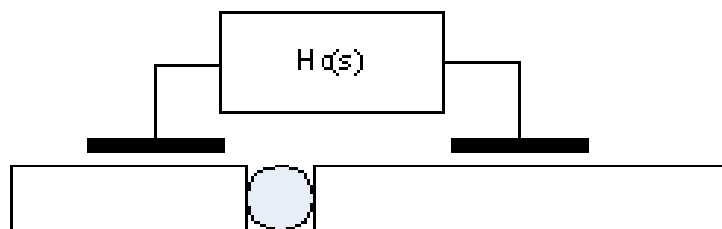

(a) System attached to a steady body segment

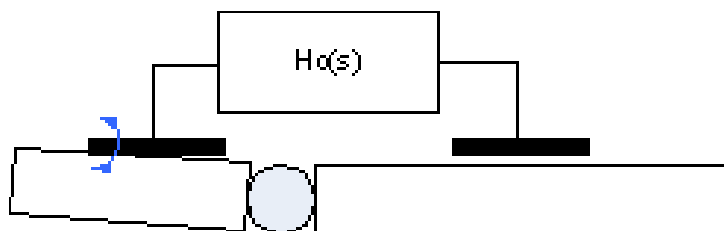

(b) Loss of alignment when the body segment moves

Fig. 9. The effect of loss of alignment due to a low impedance.

##### 4.1 Length restriction

This principle is intended to deal with the low stiffness associated with the shear component of stiffness. A constraint in length between the fixation devices (figure 10) increases the overall stiffness of the contact in a factor of 4.

Without this restriction the supports corresponding to each segment can move separately. Therefore, their dynamical stiffness is in serial mode. However, if we restrict the distance between the supports (figure 10), now both supports can only move coordinately.

Consequently, both contacts are now in parallel and the overall dynamical stiffness is higher (14). Therefore, the length restriction affects the overall dynamic stiffness of the system.

$$B_t = \frac{B_o \cdot (B_{s1} + B_{s2})}{B_o + B_{s1} + B_{s2}} \quad (14)$$

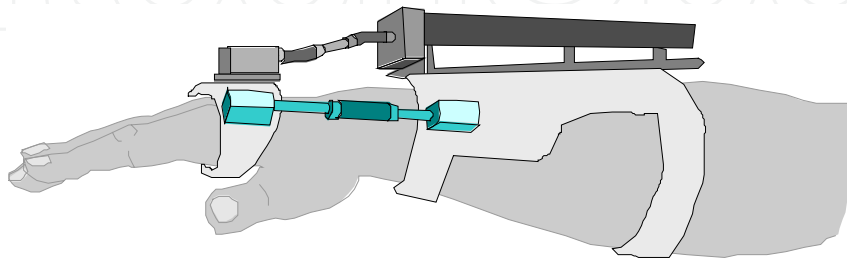

Fig. 10. Length restriction in a device to suppress tremor in the wrist flexion-extension based in a linear actuator.

Using the same simplifications as in (13) (equal impedance in both fixations and neglecting the viscous component), (14) converts to (15).

$$B_t = \frac{2K \cdot B_o}{2K + B_o} \quad (15)$$

Comparing (15) with (13) we can see that now the equivalent stiffness of the contact is four times higher.

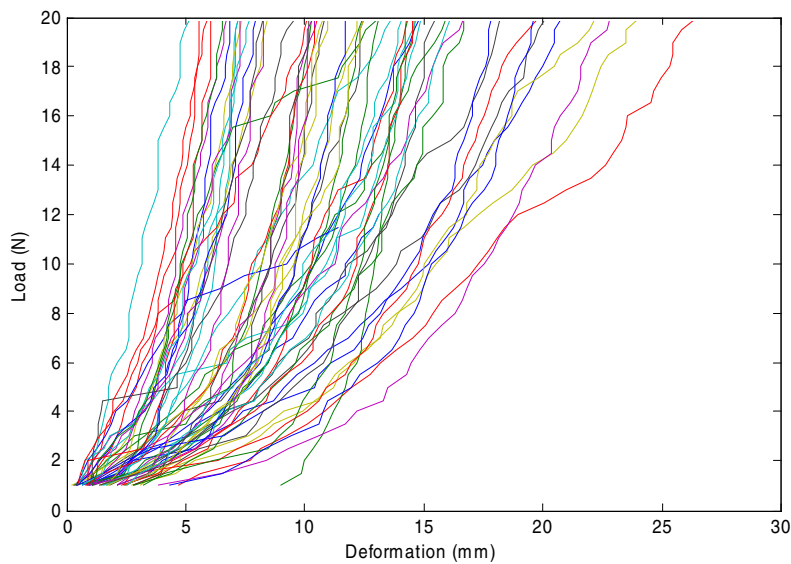

Fig 11. Force deformation characteristics of soft tissues in the forearm.

#### 4.2 Increase of contact pressure

The tenso-deformational characteristics of the soft tissues under the arm are highly non-linear. The stiffness of the tissues increases as contact pressure increases. Figure 11 shows the force-displacement curve measured in the forearm of 10 different young people (5 males and 5 females) measured in 6 points of the forearm (3 in the palmar side and 3 in the volar side).

As we can infer from figure 11, one way to increase contact impedance is increasing contact pressure and moving upwards in the tenso-deformational curve. This strategy has two constraints of safety and comfort that have been dealt with in point 3.1.

#### 4.3 Alignment with body segments

As it has been said before, the loss of alignment between the body segment and the robotic system can reduce the overall performance of the system. One way to ensure the alignment is increasing the number of contact points of each support. Each support part of the system should have at least three contact points to ensure the alignment (figure 12).

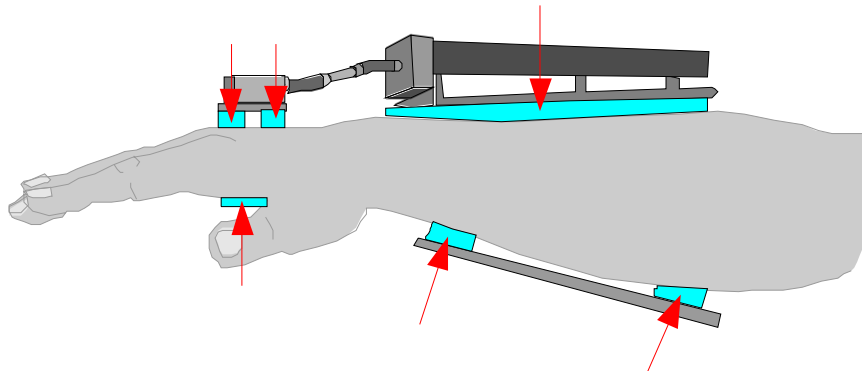

Fig 12. Alignment of the support devices with the body segments once the number of contact points have been increased.

### 5. Conclusions

Tremor suppression with robotic devices can be an alternative for people with pathological tremor resistant to conventional treatments.

Common orthotic principles don't fit well for tremor suppression due to the inherent dynamic characteristics of tremor.

In the design of robotic systems for tremor suppression the correct design of load transmission to the bones through the soft tissues is one of the key aspects for successful performance.

We have summarised the design specifications into three guidelines:

- a) Length restriction to avoid the low stiffness associated in the shear plane.
- b) Increase of contact pressure to increase contact stiffness.
- c) Increase of the number of contact points to keep the alignments between the orthosis and the body segment.

## 6. References

- Acosta, A M; Kirsch, R F & Perreault, E F (2000) A robotic manipulator for the characterization of two-dimensional dynamic stiffness using stochastic displacement perturbations. *Journal of Neuroscience Methods*, Vol. 102, (177-186), ISSN 0165-0270
- Byström, S; Hall, C; Welander, T & Kilbom, A (1995) Clinical disorders and pressure-pain threshold of the forearm and hand among automobile assembly line workers. *Journal of Hand Surgery*, Vol. 20, No. 6, (782-790). ISSN 1753-1934.
- Dandekar, K; Raju B I & Srinivasan M A (2003). 3-D Finite-Element Models of Human and Monkey Fingertips to Investigate the Mechanics of Tactile Sense. *Journal of Biomechanical Engineering*, Vol. 125, (682-691), ISSN 0148-0731
- Deuschl, G; Bain, P & Brin, M (1998) Consensus Statement of the Movement Disorder Society on Tremor. *Movement Disorders*, Vol. 13, Supplement 3, (2-23), ISSN 0885-3185
- Deuschl, G; Wenzelburger, R & Raethjen, J (2000) Tremor. *Current Opinion in Neurology*, Vol. 13, (437-443), ISSN 13507540
- Gonzalez, J C; Heredia, E A; Rahman, T; Barner, K E & Arce, G R (2000) Optimal Digital Filtering for Tremor Suppression. *IEEE Transactions on Biomedical Engineering*, Vol. 47, No. 5, (664-673), ISSN 0018-9294
- Goonetilleke, R S (1998). The Comfort "Slip". *Proceedings of the First World Congress on Ergonomics for Global Quality and Productivity*, July 8-11, 1998, R Bishu; W Karkowski y R Goonetilleke (Eds.), Hong Kong University of Science and Technology, Hong Kong, pp. 290-293
- Kotovskiy, J & Rosen, M (1998) A wearable tremor suppression orthosis. *Journal of Rehabilitation Research and Development*, Vol. 35, No. 4, (373-384), ISSN 0748-7711
- Landis, E (1930) Micro-injection studies of capillary blood pressure in human skin. *Heart*, Vol. 15, (209-228).
- Loureiro, R C V; Belda-Lois, J M; Rocon, E; Pons, J L; Normie, L & Harwin, W S (2006) Upper Limb Tremor Suppression Through Viscous Loading - Design, Implementation and Clinical Validation. *International Journal of Assistive Robotics and Mechatronics*, Vol. 7 No. 2, (11-19), ISSN 1975-0153
- Manto, M; Rocon, E; Pons, J; Davies, A; Williams, J; Belda-Lois, J M & Normie, L (2004). An Active Orthosis To Control Upper Limb Tremor: The Drifts Project (Dynamically Responsive Intervention For Tremor Suppression). *EURO-ATAXIA Newsletter*, No. 26, (2-6)
- Pledgie, S; Barner, K E; Agrawal, S K & Rahman, T (2000) Tremor suppression through impedance control. *IEEE Transactions on Rehabilitation Engineering*, Vol. 8, No 1, (53-59), ISSN 1063-6528
- Riviere, C N & Thakor, N (1996) Modelling and cancelling tremor in human-computer interfaces. *IEEE Engineering in Medicine and Biology Magazine*, Vol. 15, No 3, (29-36), ISSN 0739-5175
- Rocon, E; Belda-Lois, J M; Sanchez-Lacuesta, J J & Pons, J L (2004) Pathological tremor management: Modelling, compensatory technology and evaluation. *Technology and Disability*, Vol. 16, No. 1, (3-18), ISSN 1055-4181

Rocon, E; Ruiz, A F; Pons, J L; Belda-Lois, J M & Sanchez-Lacuesta, J J (2005) Rehabilitation Robotics: a Wearable Exo-Skeleton for Tremor Assessment and Suppression. *ICRA 2005. Proceedings of the 2005 IEEE International Conference on Robotics and Automation*, pp. 2271 - 2276, ISBN 0-7803-8915-8, Barcelona (Spain), April 2005.

IntechOpen



## **Rehabilitation Robotics**

Edited by Sashi S Kommu

ISBN 978-3-902613-04-2

Hard cover, 648 pages

**Publisher** I-Tech Education and Publishing

**Published online** 01, August, 2007

**Published in print edition** August, 2007

The coupling of several areas of the medical field with recent advances in robotic systems has seen a paradigm shift in our approach to selected sectors of medical care, especially over the last decade. Rehabilitation medicine is one such area. The development of advanced robotic systems has ushered with it an exponential number of trials and experiments aimed at optimising restoration of quality of life to those who are physically debilitated. Despite these developments, there remains a paucity in the presentation of these advances in the form of a comprehensive tool. This book was written to present the most recent advances in rehabilitation robotics known to date from the perspective of some of the leading experts in the field and presents an interesting array of developments put into 33 comprehensive chapters. The chapters are presented in a way that the reader will get a seamless impression of the current concepts of optimal modes of both experimental and applicable roles of robotic devices.

### **How to reference**

In order to correctly reference this scholarly work, feel free to copy and paste the following:

Juan-Manuel Belda-Lois, Alvaro Page, Jose-Maria Baydal-Bertomeu Raket Poveda and Ricard Barbera (2007). Biomechanical Constraints in the Design of Robotic Systems for Tremor Suppression, Rehabilitation Robotics, Sashi S Kommu (Ed.), ISBN: 978-3-902613-04-2, InTech, Available from:  
[http://www.intechopen.com/books/rehabilitation\\_robotics/biomechanical\\_constraints\\_in\\_the\\_design\\_of\\_robotic\\_systems\\_for\\_tremor\\_suppression](http://www.intechopen.com/books/rehabilitation_robotics/biomechanical_constraints_in_the_design_of_robotic_systems_for_tremor_suppression)

# **INTECH**

open science | open minds

### **InTech Europe**

University Campus STeP Ri  
Slavka Krautzeka 83/A  
51000 Rijeka, Croatia  
Phone: +385 (51) 770 447  
Fax: +385 (51) 686 166  
[www.intechopen.com](http://www.intechopen.com)

### **InTech China**

Unit 405, Office Block, Hotel Equatorial Shanghai  
No.65, Yan An Road (West), Shanghai, 200040, China  
中国上海市延安西路65号上海国际贵都大饭店办公楼405单元  
Phone: +86-21-62489820  
Fax: +86-21-62489821



© 2007 The Author(s). Licensee IntechOpen. This chapter is distributed under the terms of the [Creative Commons Attribution-NonCommercial-ShareAlike-3.0 License](https://creativecommons.org/licenses/by-nc-sa/3.0/), which permits use, distribution and reproduction for non-commercial purposes, provided the original is properly cited and derivative works building on this content are distributed under the same license.

IntechOpen

IntechOpen