

# We are IntechOpen, the world's leading publisher of Open Access books Built by scientists, for scientists

6,900

Open access books available

185,000

International authors and editors

200M

Downloads

Our authors are among the

154

Countries delivered to

TOP 1%

most cited scientists

12.2%

Contributors from top 500 universities



WEB OF SCIENCE™

Selection of our books indexed in the Book Citation Index  
in Web of Science™ Core Collection (BKCI)

Interested in publishing with us?  
Contact [book.department@intechopen.com](mailto:book.department@intechopen.com)

Numbers displayed above are based on latest data collected.  
For more information visit [www.intechopen.com](http://www.intechopen.com)



---

# Current Issues and Problems in the Joining of Ceramic to Metal

---

Uday M.B., Ahmad-Fauzi M.N.,  
Alias Mohd Noor and Srithar Rajoo

Additional information is available at the end of the chapter

<http://dx.doi.org/10.5772/64524>

---

## Abstract

Ceramics and metals are two of the oldest established classes of technologically useful materials. While metals dominate engineering applications, ceramics have some attractive properties compared to metals, which make them useful for specific applications. The properties of individual ceramics and metals can vary widely; however, the characteristics of most materials in the two classes differ significantly. Joints between a metal and ceramic are becoming increasingly important in the manufacturing of a wide variety of technological product. But joining ceramics to metallic materials often remains an unresolved or unsatisfactorily resolved problem. This chapter deals with problems of various studies in recent years on the joining between two materials.

**Keywords:** ceramic, metal, joining, problems, reliability

---

## 1. Introduction

The successful application of ceramics in many devices and structures requires some type of joining with metal [1]. Therefore, the ceramic-metal joints are used widely in the different applications such as vacuum tubes, high voltage feed through, transistor packages, sapphire-metal windows, rocket igniter's bodies and many others [2]. The new joining purposes for these materials involve automobile engine components, such as the silicon carbide, silicon nitride and yettria-stabilized zirconia. The ceramic rotor was joined to metal shaft by new method which compensated problems in both shrink fitting and active brazing methods. The designing of ceramic rotor was carried out in order to ensure the strength and durability of the component

as well as to obtain the same aerodynamic characteristics as in the metal rotor. All applications have depended upon improved mechanical and thermal properties, such as strength, and resistance to fatigue, creep and oxidation.

Achieving high integrity joints between ceramics and metals, however, is a challenge. The properties of ceramics that make them attractive may pose major handicaps for joint fabrication. Due to the chemical inertness of ceramics, conventional joining methods for metals cannot be used. To obtain adequate bond quality, high temperature and pressure are often required [3] and bonding media with reactive elements have been used [4]. The chemical phenomena occurring at interfaces determine the structure of the interface and hence, its properties. The chemical reaction between the ceramic and the metal may easily initiate bond formation; however, thick brittle reaction layers or intermetallics formed at the interface often cause premature failure at very low stresses [5].

Even successful joint formation does not guarantee mechanical soundness of the joint. The inherent differences in physical properties between the ceramic and the metal make it very difficult to find an effective process to join that keeps detailed and comprehensive strength and flexibility. There are two primary factors that cause the reliability issue of joint such as the coefficient of thermal expansion (CTE) mismatch and the difference in the nature of the interface bond. The thermal residual stresses are induced in a joint during cooling due to the CTE mismatch and differing mechanical responses of ceramic and metal. This may lead to a detrimental influence on joint strength [5, 6].

The aim of this chapter deals with problems of various studies in recent years on the joining between two dissimilar materials. The focus is on the general problems, solutions and factors influencing reliability with different ceramic-metal joining processes.

## 2. General problems in ceramic-metal joint

There exist many problems between ceramic and metal materials, such as the atom bond configuration, chemical and physical properties, etc. These problems make the joining of ceramics to metals difficult. The following main problems such as ionic bonds and covalent bonds are characteristic atomic bond configurations of ceramic materials. The peripheral electrons are extremely stable. Using the general joining method of fusion welding to join ceramics with metals is almost impossible, and the molten metal does not generally wet on ceramic surfaces [7].

When joining ceramics to metals with the brazing method, for example, metallization on the ceramic surface is necessary with general inactive brazing filler metal or the use of active brazing alloys in order to get a reliable joint. The thermal expansion coefficients of ceramics are generally much lower than metals. Stress will be generated in the ceramic/metal joint due to the thermal expansion mismatch and will degrade the mechanical properties of the joint and can cause joint cracking immediate after the joining process. The thermal stress in the joint due to the thermal expansion mismatch should be carefully considered when joining ceramic

with metal. Many ceramics have low thermal conductivity and susceptibility to thermal shock. Using the fusion welding method to join ceramics by concentration heating or with a high energy density heat source, cracking in the ceramic easily occurs. It is necessary to reduce the temperature gradient in and around the fusion zone as much as possible and to carefully control the heating and cooling speed during the joining process.

### 3. Factors influencing reliability of ceramic-metal joint

Joining ceramics to metallic materials is not so easy to be carried out without considerations of several problems originating from the differences in physical and chemical natures between ceramics and metals to be joined [8, 9]. **Figure 1** summarizes the several points, which may cause large scatter in the strength directly. From the microscopic view, interface contact formed by wetting, chemical and physical reaction at interfaces should be of concern in the first place [10]. The cracking in the layer frequently reduces joint strength. Thermal or residual stress in a joint becomes the other important factor. Large thermal stress both in joining process and in services induces flaws into joints. These factors will reflect the distribution of unbonded or weakly bonded is a land like defects on interfaces resulting in substantial reduction in joint strength [11, 12].

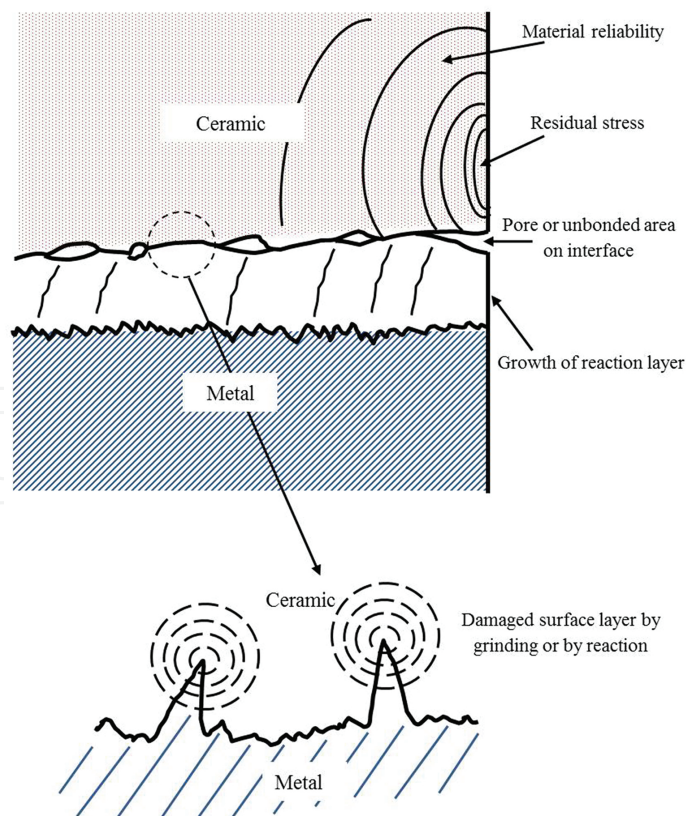

**Figure 1.** Schematics of factors influencing on reliability of ceramic/metal joint [1, 12].



The development of residual stresses is one of the major problems in the ceramic/metal joining at the interface when the material is cooled down from the bonding temperature to room temperature [13]. These residual stresses reduce the strength of the bonded material and in some cases lead to catastrophic failure at or near an interface, during the joining process. The mechanical analysis of a joint metal to ceramic is a very complex problem. There are many different characteristics to look at ceramic/metal joints. Depending on the detailed application, some characteristics are more important than others [14]. Therefore, in the following sections, we will focus in the joining problems researches for factors influencing on reliability of ceramic/metal joint.

### **3.1. Material reliability**

The ceramic, because of its inherent brittleness, is the most critical material for obtaining reliable joints [15]. The base properties of the bulk ceramic member are essential. When the properties of the bulk ceramic are not sufficient, the thermal stress simply fractures the ceramic member. Furthermore, the surface condition of the ceramic is also very important for the joint reliability. The ceramics are produced by the different forming methods and a subsequent densification during sintering at high temperatures. Due to high hardness and brittleness of ceramic, any shaping complicated treatment often needs diamond cutting tools and abrasives. Whereas it should avoid sharp edges and corners that may cause the concentration of tensile stress [16]. Moreover, when the ceramic material is ground by a metal bonded diamond wheel, microcracks are introduced at the surface of the ceramic. The size of the microcracks depends on the diamond grit size of the wheel and also on the rate of material removal. The surface damage can initiate major cracks in the ceramic by the thermal stress and, hence, result in an unreliable joint. Therefore, the ceramic surface should be free of damage to obtain high reliability joints. This condition can be met simply by using sintered ceramic materials. However, nearly all sintered ceramic parts over about 2 cm in size should be grounded, because distortion of the parts during the sintering requires grinding for dimensional control. Ground ceramic materials should be treated further to obtain a defect free surface condition. This can be performed by a resintering or lapping process. In the resintering process, the damaged layer is healed through sintering. In the case of the lapping process, the damaged layer is physically removed. It should be mentioned that the thickness removed by the lapping must completely eliminate the surface damages [15].

### **3.2. Thermal expansion and residual stress**

Residual stresses are stresses that remain in the materials joining after the original cause of the stresses have been removed. Thermal residual stresses play the key role in the mechanical behaviour of various joint materials. Thermal stresses may occur in a heated structure which is rigidly constrained, and also in a structure with temperature gradients. Thermal residual stresses in the ceramic/metal joints can be classified into three groups in accordance with the mechanism that produces them. First, thermal stresses caused by a volumetric change, either expansion or shrinkage, associated with phase transformation. For these stresses arise from a phase change, the temperature must change to cause the phase change. Second, thermal

stresses caused by a difference in CTE mismatch between two materials joined together. For these stresses to arise from a difference in coefficients of thermal expansion, the temperature may be changing or it may have stabilized. Third, thermal stresses caused by a thermal stresses caused by a temperature gradient resulting in the thermal differential rates within the volume of the material or within the structure and potentially lead to cracking. For these stresses to arise from differential rates of expansion or contraction, the temperature must change and produce a gradient, which may or may not persist. Whether the temperature gradient persists or not, the thermally induced stresses from this source persist [17].

Ceramic-metal joints represent an important class of components because of their applications in hostile environments. Examples can be found in different application such as automotive, microelectronics, the aerospace industry or biomedical applications. Generally, a ceramic-metal joint develops a residual stress field, which has its origin in the thermomechanical fabrication process and is due to the difference in CTE between the ceramic and metal (**Figure 2**). Residual stresses have significant effects on the mechanical stability of the interface, since they may cause plastic deformations on the metal side and cracking in the ceramic, thus compromising the adhesion or even inducing failure of the joint.

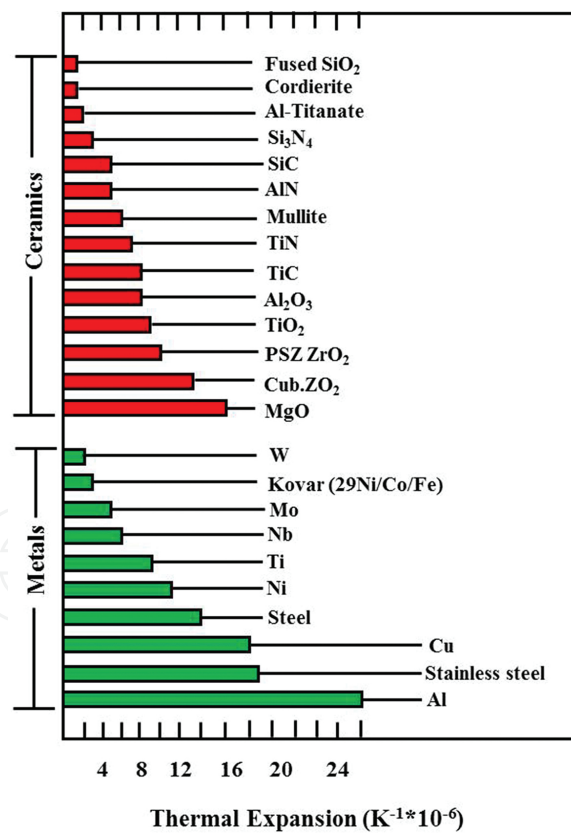

**Figure 2.** Comparison of thermal expansion coefficients of metals and ceramics [18].

The residual stresses produced in the ceramic metal joint could be estimated for full elastic conditions according to this equation [7]:

$$\sigma_c = \frac{\Delta\alpha \times \Delta T \times E_m \times E_c}{(E_m + E_c)} \quad (1)$$

where  $\sigma_c$  is the residual stress after the joint cools to room temperature,  $\Delta\alpha$  is the difference of thermal expansion coefficient between materials,  $\Delta T$  is the difference between joining temperature and room temperature,  $E_m$  is a Young's model of metal,  $E_c$  is a Young's model of ceramic. If the thermal stresses in the metal exceed its yield strength, the residual stresses in the joint could be determined by [7]:

$$\sigma_c = \sigma_{my} + \Delta\alpha \cdot \Delta T \cdot E_{mp} \quad (2)$$

where  $E_{mp}$  is the linear strain hardening coefficient and  $\sigma_{my}$  is the yield strength of the metal (linear elastic-linear plastic conditions are assumed).

The distribution of thermal residual stress is not uniform in the joint and even along the interface between these different materials. The concentration of thermal stress becomes more intense with the proximity of the interface [19]. The most harmful effect of thermal stress is caused by the tensile stress at the interface or in the ceramic. The direction of the maximum tensile stresses is mainly perpendicular to the interface and the free surface direction, causing the crack opening and failure occurs. The breadth of thermal residual stress depends on the shape and dimension of the ceramic/metal interface [20]. For example, the diameter dependence of the thermal stress of the  $\text{Si}_3\text{N}_4$ /invar alloy joint measured on the surface near the interface as shown in **Figure 3**. The larger diameter leads to generate more thermal residual stress. It is also noteworthy that stress concentration at the corner of the rectangular bond face joint is more serious. The joint strength tends to decrease with increasing thermal expansion

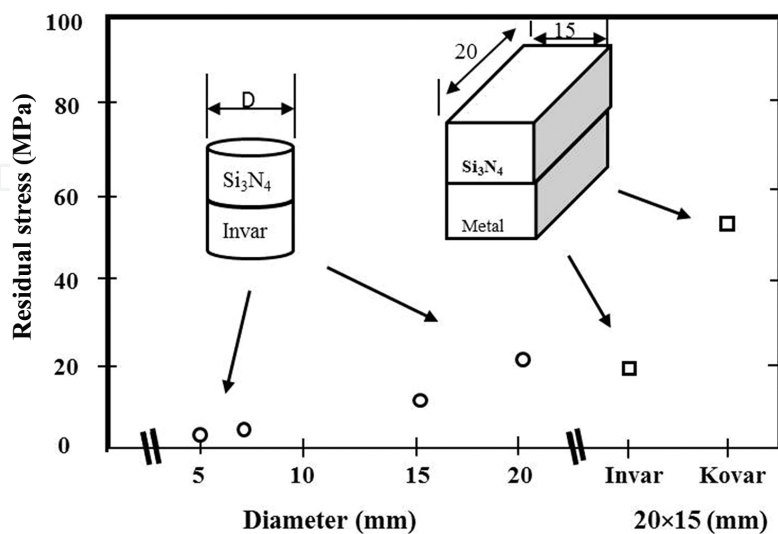

**Figure 3.** Effect of size and shape of bond face of residual stress on  $\text{Si}_3\text{N}_4$ /invar alloy joints. The residual stress was vertical to the interface on the  $\text{Si}_3\text{N}_4$  surface [22].

mismatch. However, it occasionally happens that some specimen will be strong but the other will be weak even if they are the same kind [20]. This depends on the presence and distribution of internal flaws induced by residual stress during joining. The strengths of the  $\text{Si}_3\text{N}_4/\text{invar}$  (iron-nickel alloy) and  $\text{Si}_3\text{N}_4/\text{kovar}$  (iron-nickel-cobalt alloy) joints, which are differing in the amplitude of thermal stress, were examined statistically [21].

The thermal stress may be relieved by two different methods according to Lemus-Ruiz's thesis [23]. One method inserts a metal with approximately the same thermal expansion coefficient as that of the ceramic to decrease the magnitude of thermal stress generated, while the other method involves thermal stress relief by using a ductile metal that easily develops plastic deformation under thermal stress. These two methods may also be employed in combination. **Figure 4** shows a schematic illustration of thermal stress at a joint interface and the mode of cracking due to difference of thermal expansion coefficient [24]. When the thermal expansion coefficient,  $\alpha_C$  of the ceramic is smaller than that of the metal,  $\alpha_M$ , the ceramic is subjected to tension stress and cracks at the edges, as schematically illustrated in **Figure 4a**, on the other hand, when the thermal expansion coefficient,  $\alpha_M$ , of the metal is smaller than that of the ceramic,  $\alpha_C$ ; tensile stress acts on the core of the ceramic and cracks the ceramic, not at the edges, but transversely at the core, as shown in **Figure 4b**.

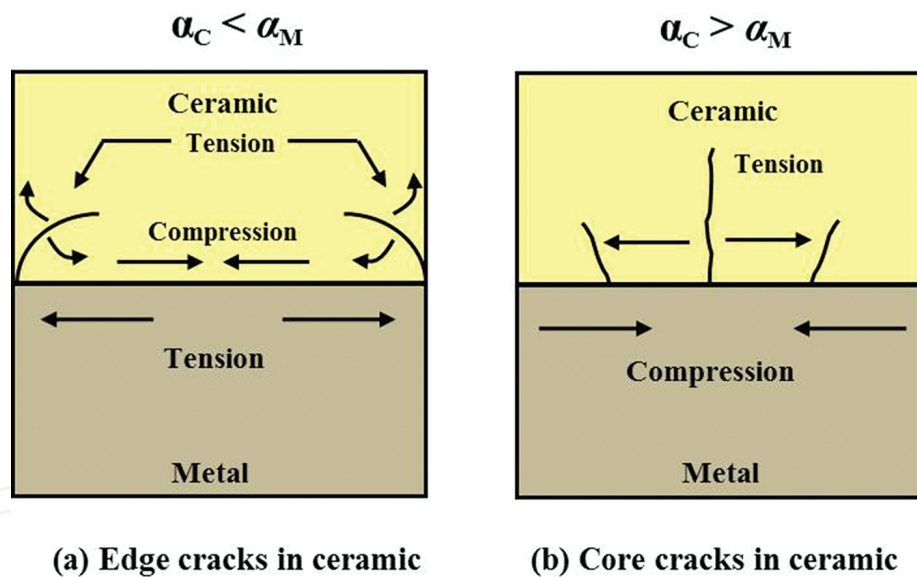

**Figure 4.** Schematic illustration of thermal stress in joint interface and mode of cracking due to difference of thermal expansion coefficient [23, 24].

To overcome for reducing the residual stress mentioned above, induced by the mismatch of the thermal expansion coefficient between the materials to be joined, the following methods can be used as reported by Zhou [7]: (1) Using soft filler metals, the soft filler metals have low yield strength and could release the residual stress. (2) Using soft interlayer, the residual stress could be reduced by the elastic and plastic deformation of an interlayer, e.g. when using Al or Cu as interlayer, the residual stress is decreased. According to Eq. (1), the residual stress will decrease with Young's model  $E_m$  decreasing. (3) Using hard metals of which the thermal

expansion coefficient is close to ceramics as the interlayer. Using hard metals such as W, Mo or invar as the interlayer, could reduce the residual stress. Their validity is not obvious when hard metals with high yield strength are the interlayer. (4) Using composite interlayer where the composite interlayers often constitute hard metals and soft metals, like Cu/Mo-Cu/Nb, have a noticeable effect on reducing residual stress, with a combination of merits of those two kinds of metals. (5) Joining under low temperature where the joining ceramic to metal at a low temperature is good for reducing the joint deformation and effectively decreasing the residual stresses. (6) Heat treatment after joining because the proper heat treatment post joining sometimes releases the stress and the strength will vary based on the heat treatment. (7) Appropriate configuration of the joint could decrease the stress concentration extent and reduce the residual stress.

### 3.3. Interface reliability of the joints

Interfaces play critical roles in properties of many material systems such as composites, coatings and joints. Particularly in ceramic to metal joints, the properties of interfaces have a significant effect on the mechanical reliability of the joints. The mechanism of bond formation at the interface determines the interface structure, which depends strongly on processing conditions as well as materials. The bonding mechanisms can be categorized in terms of mass transfer across the interface. When there is only charge transfer without mass transfer across the interface, the bonding is called chemical bonding. In some literature, it is also called physical bonding or adhesive bonding. When there is mass transfer across the interface such as chemical reaction and diffusion, the bonding mechanism is called chemical reaction bonding [5].

#### 3.3.1. Chemical bonding

While atoms are the smallest units for solid-state physicists, interfaces are the smallest building units for material scientists. Heterogeneous interfaces between two different types of materials change the chemical bonding and new properties are formed [25]. Thus, the chemical bonding holds a significant position as a joining technique in this case and includes a chemical bond being created between both parts of the work through utilization of chemical reactions occurring at the ceramic/metal interface. The chemical bonding problem in that joints can be widely produced by chemical bonding at the interface between ceramics (ionic bonding, covalent bonding) and metals (metal bonding), which basically have different bonding modes [26].

The driving force for formation of ceramic-metal interfaces is the decrease in free energy ( $\Delta G$ ) that occurs when intimate contact is established between the ceramic and metal surfaces [27]. The free energy change per unit area of interface formed is given by the Dupré equation [5]:

$$\Delta G = \gamma_M + \gamma_C + \gamma_{MC} \quad (3)$$



where  $\gamma_M$  and  $\gamma_C$  are the surface energies of the metal and ceramic, respectively, and  $\gamma_{MC}$  is the metal/ceramic interfacial energy (**Figure 5**). When the bonding is chemical bonding and interfacial separation occurs without plastic deformation of the metal and the ceramic,  $\Delta G$  is identical to the work of adhesion,  $W_{ad}$ , which is the work required to separate a unit area of interface into the two original surfaces. Combined with the Young's equation [28], Eq. (3) can be expressed as [26]:

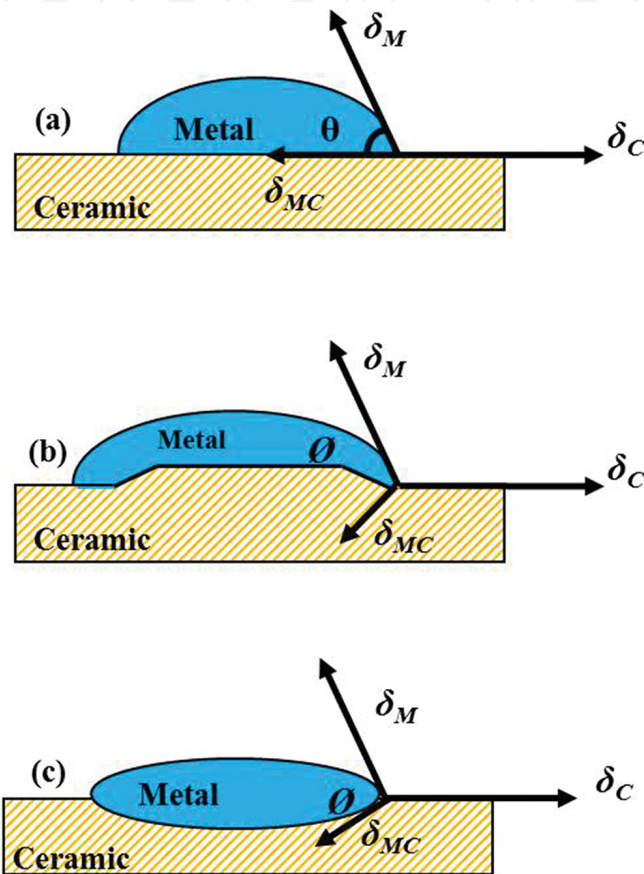

**Figure 5.** Liquid metal drop shape depending on the contact time: (a) initial contact or rigid solid surface, (b) formation of a ridge (vertical scale exaggerated) and (c) final equilibrium configuration on deformable solid [29].

$$W_{ad} = \gamma_M + \gamma_C - \gamma_{MC} = \gamma_M (1 + \cos \theta) \quad (4)$$

where  $\theta$  is the measured contact angle between the liquid or the solid and in equilibrium with a solid substrate. From Eq. (4), it is clear that the interfacial energy of the ceramic/metal,  $\gamma_{MC}$ , decreases as  $W_{ad}$  increases.

From **Table 1** it can be seen that, in general,  $\gamma_{MC}$  for  $Al_2O_3$ -metal systems tends to increase with the cohesive energy of the metal, which is directly related to its melting temperature ( $T_m$ ). On the other hand, if the ceramic-metal is a solid-solid system,  $W_{ad}$  can be estimated by measuring the dihedral angle,  $\theta$ , associated with residual voids on diffusion bonded interfaces [23].



System	$\gamma_{MC}$ (J/m <sup>2</sup> )	$T_m$ of metal (°C)
Al <sub>2</sub> O <sub>3</sub> -Ag	1.57 at 700°C	960
Al <sub>2</sub> O <sub>3</sub> -Au	1.80 at 1000°C	1063
Al <sub>2</sub> O <sub>3</sub> -Cu	2.21 at 900°C	1083
Al <sub>2</sub> O <sub>3</sub> -Ni	2.20 at 1000°C	1453
Al <sub>2</sub> O <sub>3</sub> -Fe	2.73 at 1000°C	1536

**Table 1.** Interfacial energies of solid-solid Al<sub>2</sub>O<sub>3</sub>-metal systems [23].

If the interface ruptures in a brittle fashion,  $\theta$  can be measured using an atomic force microscope and  $W_{ad}$  is then obtained from [23]:

$$W_{ad} = \gamma_m(1 - \cos \theta) \quad (5)$$

Another important consequence of Eq. (3) is that a stable interface requires a positive  $\Delta G$  (or  $W_{ad}$ ). For a number of ceramic-metal systems,  $W_{ad}$  varies with the temperature, which provides an explanation for the minimum temperature requirements to achieve bonding.

### 3.3.2. Chemical reaction bonding

When there is mass transfer across the interface, bonding is formed by diffusion or chemical reactions. Chemical reactions at the interface lead to the formation of interfacial reaction layers with properties that differ from both the ceramic and the metal [5]. This can have favourable effects on joint quality by increasing the initial wettability of the metal on ceramic surfaces; however, thick reaction layers increase volume mismatch stresses and thermal residual stresses that detrimental to joint strength. **Figure 6** shows a schematic illustration of the chemical bonding methods and processes. Brazing for instance is a joining technique including the anomalies and gaps which happen on the surfaces of the work being brought into a condition of close cohesion by means of a liquid phase. It is also generally known that solid-phase joining including good adherence which accomplished through heating, pressurization, also distortion that occurs through the surfaces at work and also the interdependence of natural temperature where it seemed direct contact for a period ranging between work surfaces through the settlement and activation. It involves normal temperature tension threads that are being made to produce a full-contact interface between these materials by an energy supply from a source other than the thermal one and to create a joint in the interface in proximity to its normal temperature.

The driving force for a chemical reaction is the chemical potential of the atomic species involved. In many systems, chemical reaction is not expected if only the interaction of the metal with non-metallic elements of the ceramic is considered. However, when all the possible reaction potentials are considered, a net negative free energy can result, which indicates that a chemical reaction is thermodynamically favourable. Equilibrium thermodynamics can use to predict possible reactions at the interface. However, when there are more than three elements in a ceramic-metal system, the prediction of all the possible reactions based on the

phase diagram is nearly impossible. In addition, the extent and possibility of the reaction are limited by kinetics for which data is not readily available for ceramic-metal interfaces [30].

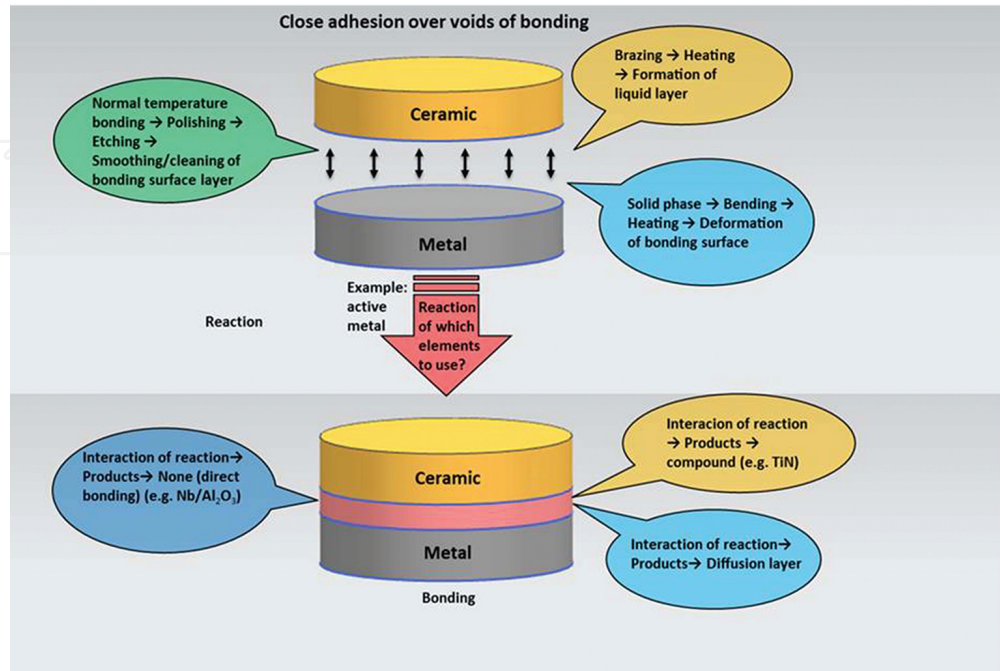

Figure 6. Chemical bonding of ceramics and metals [26].

Reaction phases such as brittle intermetallics and solid solutions often cause interfacial failure at very low stress [5]. An increase in bonding temperature and excessive time generally enhance chemical reactions and lead to thick reaction layer formation, which may decrease the joint strength. At interfaces where planar reaction layers form the thickness of the layer is often optimized by controlling bonding conditions to prevent interfacial debonding or brittle interfacial fracture along the reaction layer. In many ceramic-metal systems, it is observed that the growth of the reaction layer follows a parabolic rate law. It is found that the reaction product tends to be bonded to the ceramic with a coherent interface.

### 3.3.3. Pores and unbonded areas on interface

Unjoined area is frequently formed at the edge of a joint. This edge defect weakens the joint extremely as it works as a notch induced on the interface and one must control the formation of an edge unjoined band. The inhomogeneity in deformation of the metal layer will also reflect the strength. In the case of the reaction gas releasing system, the reaction in the outer region may be promoted by continuous evacuation. This will cause excess thinning of the ceramic at the edge region.

If the interface reaction emission gas as the reaction product, the pores loaded with the gas might be left on the interface bringing about the hindrance of contact. The Si<sub>3</sub>N<sub>4</sub>/Ni interface is one of the cases. This interface is feeble because of the nearness of pores along the interface.

At the point when nickel contains nitride forming elements, for example, chromium, no pore is formed at an interface and the strength is improved.

In the actual joining sequences, a perfect interface connection over the whole interface is hardly achieved within a certain joining period and temperature limited by the progress of interface reaction. Whereas the base surface roughness and applied pressure with a couple of critical features, which significantly affect the accomplishment of interfacial contact in the solid state bonding as well as in welding [31]. In solid-state joining, and advanced interfacial contact that plastic deformation in the next early stage that creep deformation and diffusion at a later stage. Basic effects pressure to achieve contact by plastic deformation at the elementary stage. Unjoined islands are formed inevitably on the interface joints under limited pressure. It will depend on the breadth of pressure, time, temperature and different material factors such as stress flow [32]. The relationship between the fracture stress and the unjoined area of the solid-state bonded  $\text{Al}_2\text{O}_3/\text{Nb}$  joint are shown in **Figure 7**. Apparently, the increase in unjoined area decreases the strength of the specimen [33].

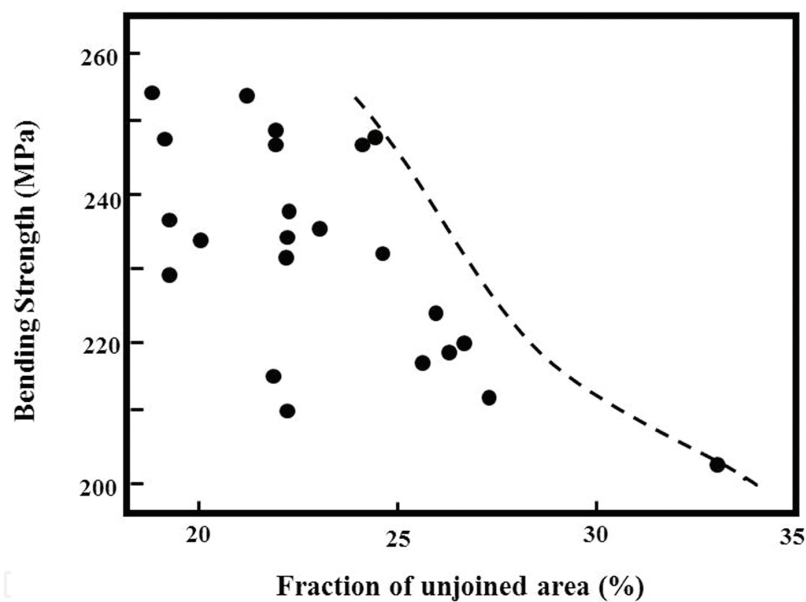

**Figure 7.** Bending strength of individual  $\text{Al}_2\text{O}_3/\text{Nb}$  joints as a function of unjoined area formed on interface [32].

### 3.4. Mechanical reliability of the joints

The important factor in mechanical reliability is a deviation in the mechanical strength. Knowing the distribution mode of the strength of ceramic/metal joints is significant for the evaluation of reliability. Ceramic materials have a strength distribution obeying the Weibull theory in general. Several researchers suggested the possibility of adopting the Weibull theory to the distribution of the strength of ceramic/metal joints [19].

In the Weibull theory, the cumulative distribution function of fracture,  $F(\sigma)$ , is written as [19, 34]

$$F(\sigma) = 1 - \exp\left(-\int_{\gamma}^{\sigma} \left(\frac{\sigma - \sigma_u}{\sigma_0}\right)^m dV\right) \quad (6)$$

where  $\sigma_u$ ,  $\sigma_0$  and  $m$  are the zero probability strength (location parameter), the scale parameter and the flaw density exponent (shape parameter). Below  $\sigma_u$  the stress becomes zero; conventionally,  $\sigma_u$  is set to be zero.

**Figure 8** illustrates the sample geometry and test configuration used in the mechanical characterization of ceramic/metal joints. This characterization of the interfacial strength by pull-off or shear-off tests has several limitations. The first one relates to the variety of techniques used by different research groups, making it difficult to establish a mutual comparison of results. The shear test provides an alternative way to assess the mechanical strength of interfaces. Samples are easily produced, but the results are generally lower than those obtained for bend and tensile tests. The selection of an appropriate method for measuring the bond strength is dictated by the purpose of testing, but the bonding process and parameters affecting the mechanical quality of the bond can be monitored by both fracture mechanics and conventional testing methods. The bond strength values obtained also depend on the testing technique chosen. Bend test values are generally higher than tensile test values for joints and for brittle ceramic materials. The shear stress test is one of the simplest techniques. However, the shear stress at the interface is not simple shear and it always contains a component of tensile stress that originates from a bending moment, which cannot be neglected. The influence of a slight change of the push position and the fixing condition on the stress distribution is very important. Therefore, the shear test is not recommended for the common evaluation method. Bending and tensile test has almost the same stress distributions as those derived from

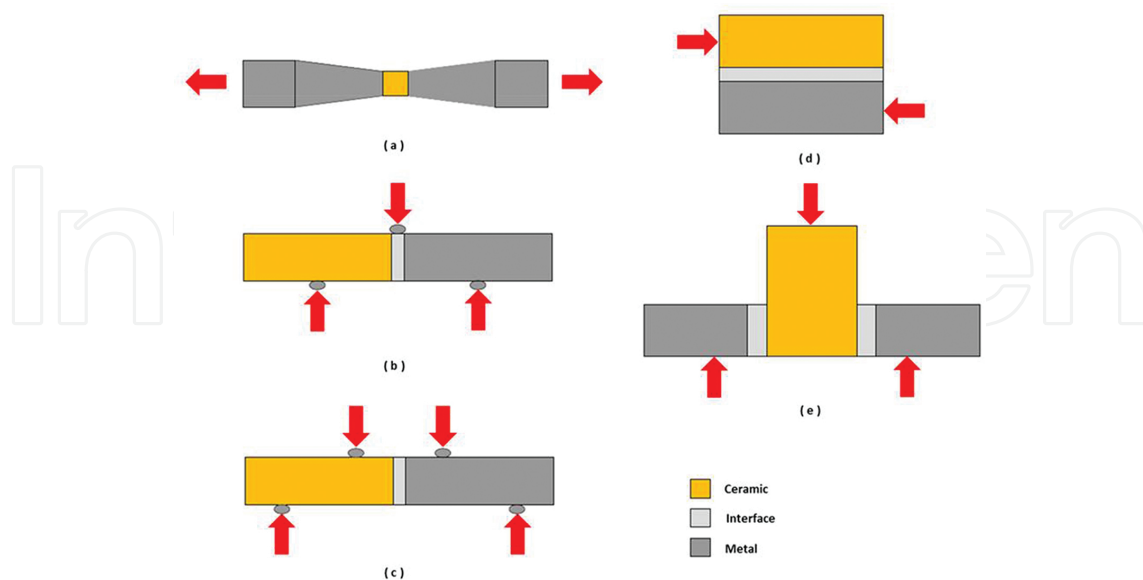

**Figure 8.** Sample geometry for mechanical tests of joining specimens: (a) tensile; (b) three-point bending, (c) four-point bending, (d) plain shear and (e) shear on ring/cylinder [1, 30].

analytical equations. However, the elastic constant mismatch between ceramics and metal induces inhomogeneity in stress distribution [23].

In the case of three-point bending, the peak stress occurs only along a single line on the surface of the test bar opposite the point of loading. The tensile stress decreases linearly along the length of the bar into the thickness of the bar, reaching zero at each bottom support and at the neutral axis, respectively. The probability of the largest flaw in the specimen being at the surface along the line of peak tensile stress is very low. Therefore, the specimen will fracture at either a flaw smaller than the largest flaw or a region of lower stress. Four-point bend testing results in lower strength values for a given ceramic material than does three-point bending. The peak of the stress distribution in a four-point bend specimen is present over the area of the tensile face between the load points. The tensile stress decreases linearly from the surface to zero at the neutral axis and from the load point to zero at the bottom supports. The area and volume under peak tensile stress or near peak tensile stress is much greater for four-point bending than for three-point bending, and thus the probability of a larger flaw being exposed to high stress is increased. As a result, the modulus of rupture (MOR) or bend strength measured in four-point is lower than that measured in three-point. Uniaxial tensile strength results in lower strength values for a given ceramic than does bend testing. **Figure 9** illustrates that in the case of uniaxial tension the complete volume of the gauge section of a tensile test specimen is exposed to the peak tensile stress. Therefore, the largest flaw in this volume will be the critical flaw and will result in fracture.

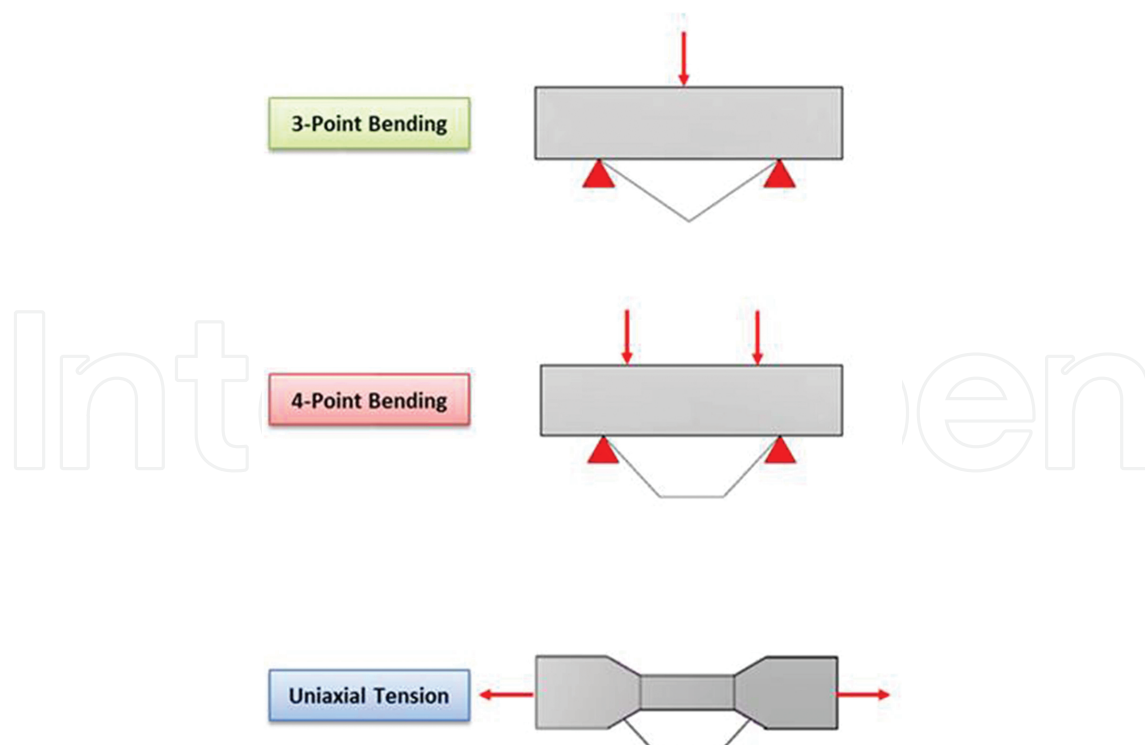

**Figure 9.** Comparison of the tensile stress distributions for three-point, four-point and uniaxial tensile test specimens [23].

The strength of metal/ceramic joint materials is generally characterized by bending tests, also referred to as flexure testing. The test specimen can have a circular, square or rectangular cross section and is uniform along the complete length. As shown in **Figure 10**, the test specimen is supported near the ends and the load is applied either at the centre, for three-point loading, or at two positions for four-point loading.

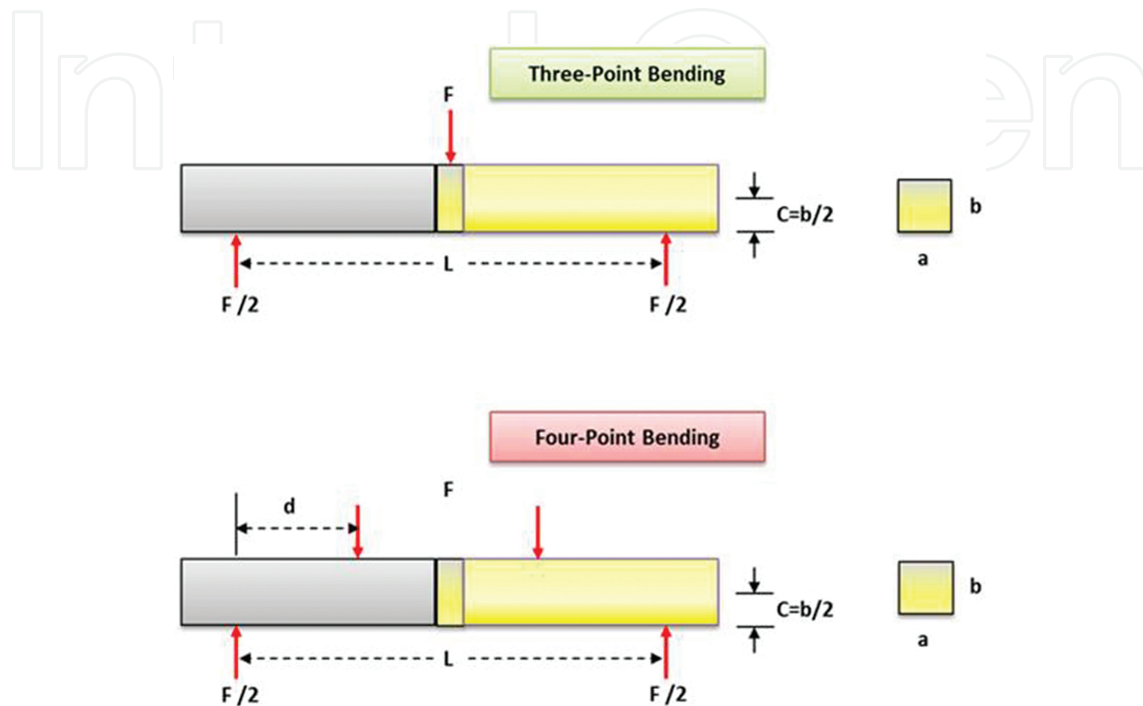

**Figure 10.** Derivation of the modulus of rupture equation for three-point and four-point bending [23].

The bend strength is defined as the maximum tensile stress at failure and is often referred to as the MOR. The bending strength of a rectangular test specimen can be calculated using the general flexure stress formula:

$$S = M.C / I \quad (7)$$

where  $M$  is the moment,  $C$  is the distance from the neutral axis to the tensile surface and  $I$  is the moment of inertia.

For a rectangular test specimen [23]:

$$I = a.b^3 / 12 \quad (8)$$

and

$$C = b / 2 \quad (9)$$



where  $b$  is the thickness and  $a$  is the width of the specimen.

From **Figure 10**, it is possible to illustrate the derivation of the three-point and four-point flexure formulas for rectangular bars. We can observe that:  $M = (L/2) \cdot (F/2)$  in the case of three-point and  $M = (F/2) \cdot d$  for four-point test.

Therefore, for three-point bending:

$$S = \sigma_{3P} = \frac{3.F.L}{2.a.b^2} \quad (10)$$

And for four-point bending test:

$$S = \sigma_{4Pt} = \frac{3.F.d}{a.b^2} \quad (11)$$

For most ceramic materials, the apparent strength will decrease when going from three-point to four-point to tensile testing and as specimen size increases.

Whatever joining processes are used, the successful formation of the joint depends on achievement of intimate contact between the base materials, conversion of the intimate contact into an atomic bonding/reaction, accommodation of residual stresses induced by different thermal and mechanical properties between the base materials undergoing temperature change. Each joining process is characterized by the methods and conditions employed to achieve intimate contact and to promote bond formation between the work pieces.

#### 4. Ceramic-metal brazing problems

Brazing is a process for joining similar or dissimilar materials using filler metal [35, 36]. The filler metal is heated slightly above its melting point so it flows, but the temperature remains lower than the melting point of the ceramic metal joints (**Figure 11**). Flux or an inert atmosphere is utilized to keep two surfaces that have joined and brazing material from oxidation during the heating process. The filler material flows over the base metal and ceramic, and the entire assembly is then cooled to join the pieces together. Brazing forms very strong, permanent joints. Brazing is considered to be well-established commercial processes for ceramic metal joints also [37], where it is widely used in industry, in different parts, because almost every metallic and ceramic material can be joined by this process. Generally, brazing can easily be performed by manual techniques, but, in many cases, it can just as easily be automated if necessary.

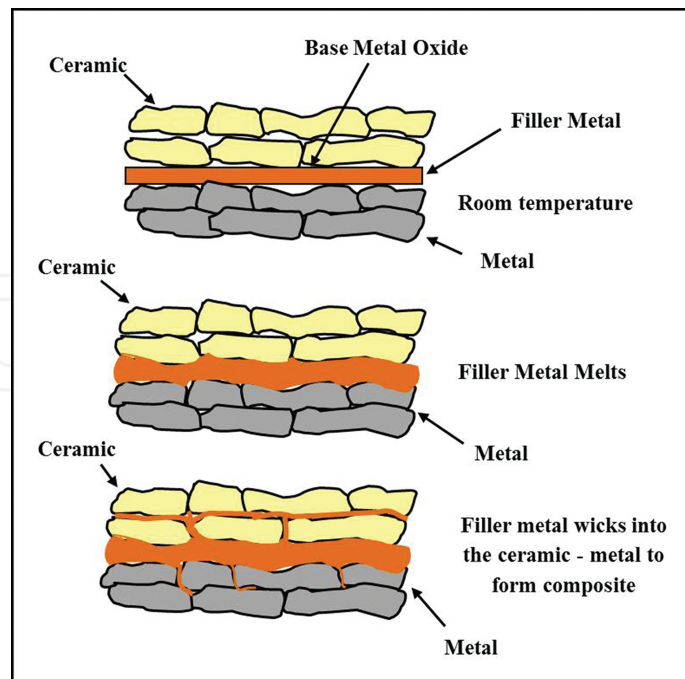

Figure 11. Brazing schematic [38].

Brazing has numerous focal points over other metal-joining methods, for example, welding [39]. Since brazing does not fuse the base metal of the joint, it permits much more tightly control over resilience and produces a perfect joint without the requirement for optional wrapping up. Furthermore, dissimilar metals and ceramic can be brazed. When all is said in done, brazing likewise creates less thermal deformation than welding because of the uniform heating of a brazed piece [39]. Complex and multi-part assemblies can be brazed cost-effective. Another feature is that the brazing can be covered or clad for defensive purposes. Finally, brazing is effectively adjusted for large scale manufacturing and it is anything but difficult to mechanize on the grounds that the individual procedure parameters are less delicate to variety [40].

One of the major disadvantages is the absence of joint strength when contrasted with a welded joint because of the softer filler metals utilized. The strength of the brazed joint is liable to be not as much as base metals but more than the filler metal [41]. Another disadvantage is that brazed joints can be damaged under high temperatures. The brazed material joints require a high purity when done in an industrial environment. Also some applications for brazing require the utilization of satisfactory fluxing agents to control cleanliness. The colour of joint is frequently not quite the same as that of the base metal, making a stylish disadvantage.

The two major problems when the joining these materials by brazing process are firstly the differences in physical properties between ceramics and metals, and secondly the poor wettability of ceramics by most metals and alloys [42, 43]. The first problem in joining ceramics to metals for high-temperature results from the huge contrasts in thermal expansion behaviour. At the point when the thermal expansion of these materials get together is modified, these differences in the thermal expansion behaviour can prompt high stresses [42]. This condition is regularly subsequently heightened by thermal inclinations that rise as a result of thermal

diffusivity contrasts between the metal and ceramic. Ceramic for the most part have high elastic moduli and low-relaxation characteristics which prevent relief or redistribution of the stresses. The low tensile strengths of most ceramics may then make them unable to resist fracture under such stresses [44, 45]. Another problem of wettability is overcome with the use of an activated braze alloy, where an active element, e.g. Al, Zr and Ti, alters the surface chemistry of the ceramic by the formation of intermediate reaction layer and lowers the wetting angle of the molten braze on the ceramic [46, 47]. The compounds that form are commonly spinels for the oxide ceramics and complex nitrides for the ceramic nitrides [39]. For the purpose of addressing this problem should be used high vacuum or high-purity reducing or inert-gas atmospheres are necessary for the successful brazing process.

Cazajus et al. [48] have studied the thermal stresses in the ceramic-metal joining after brazing process. The framework of this study is the thermomechanical analysis and the simulation of the brazing process of ceramic and metal joining. **Figure 12** gives the physical phenomena involved during brazing and their coupling relations. The brazing is a joining process which produces the coalescence of materials by heating them to a suitable temperature or by using a filler metal, having liquids under the solids of the base materials. The difference between ceramic and metal thermal expansion coefficient (CTE) leads to the development of residual thermal stresses during cooling from brazing process to room temperature which reduce the joint strength. The design of joints in material engineering and the optimization of the industrial brazing process require to control and to examine such a phenomenon. The conclusions from that paper can be drawn for different parameter effects on residual stresses during the brazing process simulation. The mechanical behaviour and geometrical parameters have a significant influence on the residual stress distribution and their maximum values. The difference between ceramic and metallic material's CTE and the metallic materials elastoplastic properties are the most important parameters of the assembly mechanical behaviour. The ratio between the alumina height and stainless steel ( $H_A/H_{SS}$ ) represents the most important geometrical factor (**Figure 13**). The cooling conditions and the filler metal yield stress evolution depending on temperature have only a significant impact on the residual stresses evolution during the brazing process and not on the final value [49, 50].

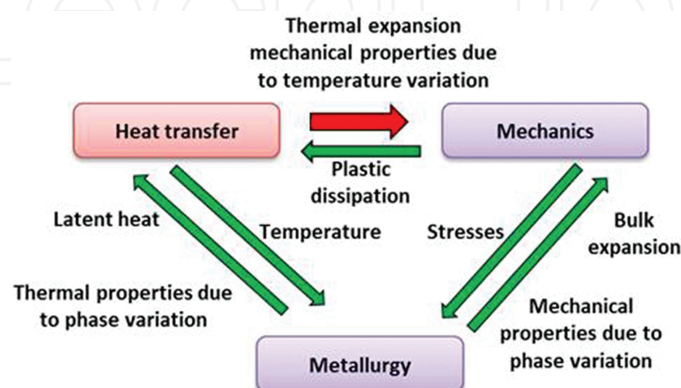

**Figure 12.** Physical phenomena during brazing process and their couplings [48].

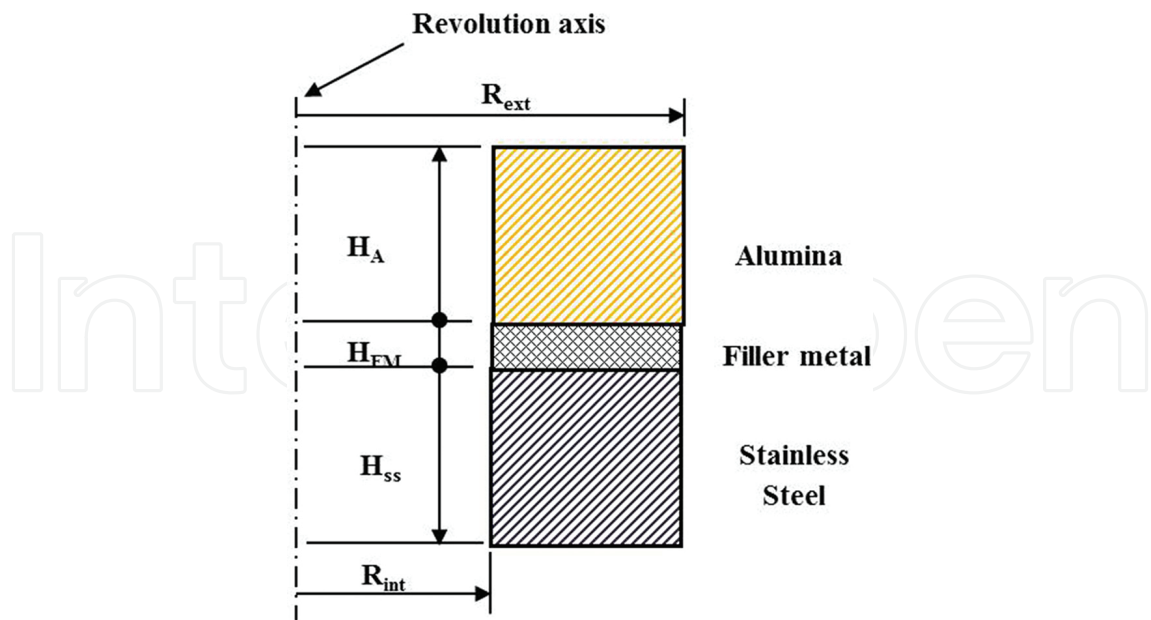

Figure 13. Geometrical parameters of the ceramic metal assembly [50].

Shirzadi et al. [51] developed the general method for brazing ceramics to metals using compliant metallic foam as a buffer layer. Using stainless steel foams, bonds between alumina and 316 Stainless Steel with shear strengths up to 33 MPa have been achieved. From this study, it is found that the utilization of metallic foam as a buffer layer between ceramic and metal could be an efficient method to avoid the mismatch that occurs in thermal expansion between the two materials when bonded together by brazing. They have been exhibited that the joints were tolerant to serious thermal cycling tests. The number of thermal cycles (200–800 °C in normal condition) to disappointment of  $67 \pm 3$  through the thermal cycling test. According to shear test results, the fracture mode was ductile because of the flexibility in the region based on the layer of foam. The fracture surfaces of the samples brazed without and with foam after

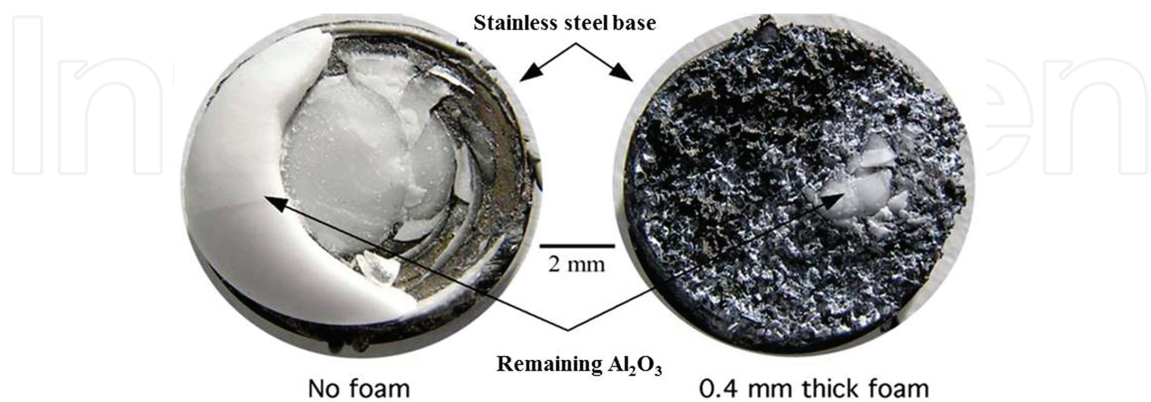
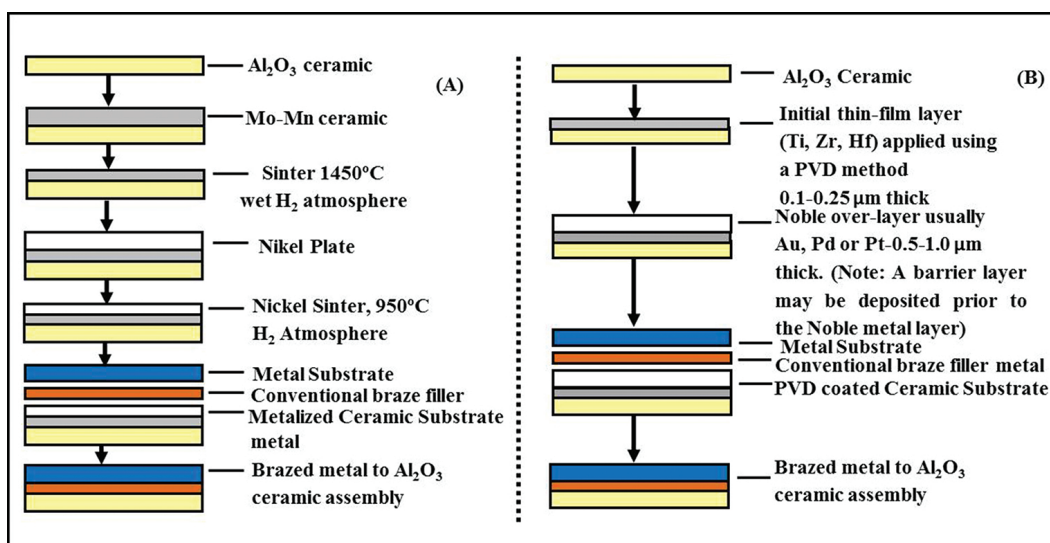

Figure 14. Fracture surfaces of joints without and with metallic foam following thermal cycling between 200 and 800 °C in air. Number of cycles to failure were  $<1$  and  $60 \pm 4$  for samples without and with a foam interlayer, respectively [51].



thermal cycling (200–800 °C in air) as shown in **Figure 14**. It showed the former ‘cup and cone’ break inside the ceramic after the first cycle, while the latter failed from the interface of the ceramic foam after more than 60 cycles.

The article of Walker and Hodges [52] is intended to familiarize the designer with brazing methods commonly used to join metals to ceramics, discussed the advantages and disadvantages of two methods, and show the relative tensile strengths obtained from samples fabricated using these methods. In most article cases discussed, 94% alumina ceramic (6% glassy phase) ASTM-F19 tensile button samples were joined to Fe-29Ni-17Co alloy using a gold-or silver-based braze filler metal (**Figure 15**). The article is limited to the two metallization methods most commonly used for joining metals to ceramics: the molybdenum-manganese/nickel plating method and physical-vapour deposition or thin-film method.



**Figure 15.** Commonly used ceramic metallization methods: (A) moly-manganese metallization process; (B) thin-film metallization process [52].

At the point when ceramics production are to be brazed, especially in those conditions where the coupling part is a metal, the individual differential thermal coefficient of thermal expansion between the coupling parts is of foremost significance. When in doubt engineers have a tendency to expect that the coefficient of thermal extension of a metal will be a few times that of a ceramic. This is not generally genuine, be that as it may. For instance ceramic, for example, silicon nitride and silicon carbide do, in fact, have low coefficient of thermal extension, and issues emerging from stresses produced amid the cooling stage can be normal in conditions where such materials are brazed to stainless steels or copper both of which being metals that have a high coefficient of thermal expansion. However, titanium, titanium alloys and some exceptional materials, for example, invar and kovar each have a coefficient of thermal expansion which is near that of alumina, while expansion coefficients of molybdenum and tungsten are near those of both silicon carbide and silicon nitride. This implies while picking the ‘active’ filler material that will be utilized for a specific employment it is fundamental to decide the differential coefficient of expansion that exists between the materials that are to be joined.

## 5. Ceramic–metal solid-state joining

Solid state joining is a gathering of joining procedures which produces cohesion at temperatures basically underneath the melting point of the base materials being joined, without the expansion of brazing filler metal. Pressure might possibly be utilized. These procedures are infrequently mistakenly called solid state bonding forms: this gathering of joining procedures incorporates friction welding, diffusion and laser welding. In all of these welding processes, the parameters such as temperature, time and pressure separately or together to produce ceramic metal joint without melting of the base metal. Solid-state bonding process contains some of very oldest processes and some of them new. The bonding processes provide certain advantages as the base metal do not melt and compose an interface. The materials that joined keep their original properties without the heat-affected zone problems included when there is no melting for base materials [53]. At the point when dissimilar metals are joined their thermal expansion and conductivity is of substantially less significance with solid state welding than with the arc welding processes. Time, temperature and pressure are included; nonetheless, in some processes the time component is to a great degree short, in the microsecond run or up to a few moments. In different cases, the time is reached out to a few hours. As temperature expands time is generally decreased. Since each of these processes is different each will be qualified.

### 5.1. Ceramic-metal friction welding

Friction welding is a solid state joining that produces a bond under the compressive force of one rotating workpiece to another stationary workpiece [54]. Heat is generated at the weld interface during the friction between two materials because of the non-stop rubbing for different contact surfaces, which is produced later in the softening of metal (**Figure 16**). Finally, the metal side at the weld interface begins to flow elastically and forms an axial shortening [55]. When a certain amount of forging had occurred, the rotation stops and the compressive force are maintained or slightly increased to consolidate the weld. Some of the important operational parameters in friction welding are friction time, friction pressure and rotation speed [56].

Friction welding, like any welding process, has its specific advantages and disadvantages. The following are some advantages of friction welding such as no filler metal is needed. Flux and shielding gas are not required. The process is environmentally clean, no arcs, sparks, smoke or fumes are generated by clean parts [58]. Surface cleanliness is not as significant, compared with other welding processes, since friction welding tends to disrupt and displace surface films. There are narrow heat affected zones. The process is suitable for welding most engineering materials and is well suited for joining many dissimilar material combinations. In some cases of weld, the strength of the joint is equal to or greater than the strength of the weaker of the two materials joined. The bond that is created by the mechanical intermixing and solidification of the two materials is strong and free from voids and porosity. It can be cost effective and offers design engineers many more options than other methods.



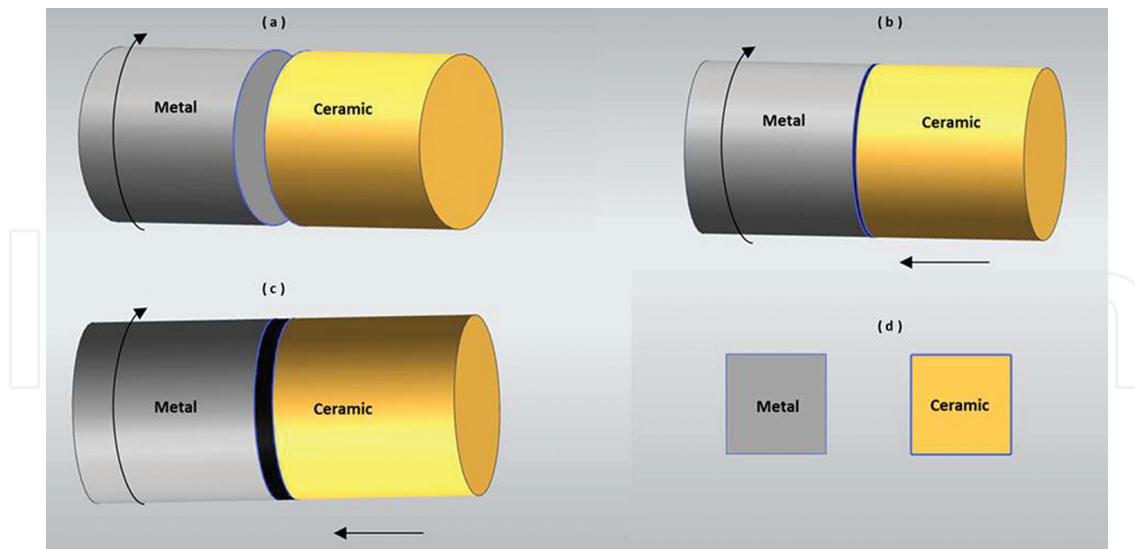

**Figure 16.** Basic steps of friction welding of ceramic and metal [57].

There are also some limitations of the process like; one workpiece must have an axis of symmetry and be capable of being rotated about that axis. Preparation and alignment of the workpieces may be critical for developing uniform rubbing and heating, particularly with diameters greater than 50 mm. Capital equipment and tooling costs are high. Dry bearing and non-forgable materials cannot be welded. If both parts are longer than 1 m, special machines are required. Free-machining alloys are difficult to weld [59].

For a particular application, heating time is determined during the setup or from previous experience [57, 60]. Excessive heating limits productivity and increase wastes material. Similarly, uneven heating as well as entrapped oxides causing unbonded areas at the interface may be due to insufficient welding time. The ranges of effective pressure are not essentially slight for forging and heating, although the selected pressures should be reproducible for any specific process. Friction pressure has influence on the axial shortening distance and the temperature gradient in the weld zone [61]. The friction pressure depends on the materials being joined and the surface joint geometry [59]. Selected pressure must be high enough to hold the faying surfaces in intimate contact to avoid oxidation. Joint quality is improved in many metals, including steels, by applying a forging force at the end of the heating period.

On the other hand, the rotational speeds are related to the welding material and welding diameter in the interface. They may have different effects on the mechanical properties of the friction joint. Increase the rotational speed may lead to more frictional heat at the interface, thus leading to a greater amount of softening materials, recrystallization, or even increased intermetallic formation [62]. In addition, depending upon the type of materials joined or more accurately, the physical and mechanical properties involved the rotational speed of the production of the various effects on the quality of the joint. Therefore, an appropriate rotation speed must be used to minimize any harmful effects and produce good quality of joints is an effective pressure range pressure.

Weiss [63] studied the residual stresses and strength of friction welded ceramic/metal joints. From this article, based on friction welding results of different ceramic materials to an aluminium alloy, the effect of residual stresses on the strength of ceramic-metal joints was calculated numerically. Heat conduction process calculations to evaluate the temperature distribution have been conducted by the method of finite element (FEM), using hardware experimental data for input. From this chapter, the theoretical analyses clearly show that edge geometry of the joint in the area of the interface (flash) has a strong effect on the weld joint strength. Improvement of weld joint strength seems to be possible by optimization of the geometry in the area of the weld interface. The effect of joining parameters on ceramic metal joint strength through residual stresses is comparatively low. However, the welding parameters may have more effect on the joint strength by means of the bonding process, resulting in higher or lower bonding strength [64].

Rombaut et al. [65] summarized of the literature review performed during the master thesis on friction welding on dissimilar materials. Of main interest in this work is the welding of steel to a ceramic material such as alumina ( $\text{Al}_2\text{O}_3$ ). Because of the difficulties involved in the production of welding sound for this material combination, and not a lot of literature is available on this topic. This work begins with a discussion about the basics of friction welding and typical problems encountered in steel welding with ceramic. There are three major reasons related to joining problems noted for these materials combination. First, there is an important variance in the type of atomic bonds between metal like steel and ceramic. The joining in the ceramic is mostly from the nature of the ionic or covalent (usually a hybrid of these), while metals have a metallic bonding character. Second, there is often a very large difference in the thermal expansion between these materials. Ceramic is usually lower coefficient of thermal expansion. When two parts of materials cool down after joining, the thermal stresses will be push in the weld interface, this may lead to cracking after that. Third, the brittle mode and porous of ceramics makes it very hard to absorb fabrication defects. The strength of a ceramic is highly dependent of its grain size and surface roughness [66, 67].

Seli et al. [68–70] presented the evaluation of mechanical and interfacial properties of friction welded alumina-mild steel rods with use of A6061 sheet as an interlayer. A preliminary simulation was made to predict the deformation, stress, strain and temperature distribution during the joining operation using a fully coupled thermo-mechanical FE model. This paper also starts with a discussion on the basics of friction welding and typical problems encountered in welding the dissimilar materials. Problems related to friction welding of dissimilar materials are not only related with specific characteristics such as melting point and hardness, but also with the reactions that occur at the joint interface. Metals generally have a coefficient thermal expansion higher than ceramics. Therefore, when joining ceramics to metals using friction welding, it will be induced very large thermal stress and in many cases these large stresses cause joint failure. In order to overcome this problem, the development of solid-phase bonding processes, which a metal or composite metal-ceramic layers are placed between the ceramic and metal surfaces to be joined [62, 71, 72].

Uday et al. [20] investigated the effect of welding speeds (630–2500 rpm) on the mechanical strength of friction welded joint of alumina-YSZ composite and 6061 aluminium alloy. From

this study, alumina-0, 25 and 50 wt.% YSZ composite with 6061 aluminium alloy joints were welded successfully by friction welding. The bending strength values of alumina-25 wt% YSZ composite joint obtained were greater at a rotational speed of 630 rpm than at 2500 rpm. The bending strength values at the joints were smaller in the pure alumina joint at a rotational speed of 1250 rpm than at 2500 rpm. The joint with large thermal expansion mismatch decreased the strength. However, it occasionally happens that some specimen is strong but the other is weak even if they are of the same kind. This depends on the presence and distribution of internal flaws induced by thermal stress during the joining process. The ceramic composite ( $\text{Al}_2\text{O}_3$ -25 wt.% YSZ) joints were welded productively at the low rotational speed (630 rpm) compared with pure alumina when joining with aluminium alloy by friction welding. The frictional heat at low rotational speeds (630 rpm) [73] produced lower temperature gradients in the surface of friction, with temperature falling in the radial direction. Friction at high speed 2500 rpm produced more heating along the whole of the interface. The lower heating of the rod end-faces reduced stresses within the rod material [59, 74].

## 5.2. Ceramic-metal diffusion bonding

Diffusion bonding is a joining method where the principal mechanism for joint formation is diffusion solid-state. Coalescence of the faying diffusion surfaces is accomplished through the application of pressure at raised temperature. No melting and limited macroscopic deformation or relative motion of different parts occurs during bonding. A filler metal (diffusion aid) can or cannot be used between the faying surfaces [75]. It has involved interest as a means of joining ceramic and successes have been realized by controlling the microstructure of the interfaces formed. The first condition for diffusion bonding is to create an intimate linking between two surfaces to be joined to the atomic species comes into intimate contact. Furthermore, to a good connection, there must be enough diffused between the materials in a reasonable period of time. Pressure can be applied by hot press or hot isostatic press on a diffusion couple. **Figure 17** shows illustrations of events during metal/ceramic diffusion bonding in solid-state [76].

Diffusion bonding is primarily employed in the joining of dissimilar materials, i.e. dissimilar metals, metal-glass, metal-ceramic and ceramic-glass, either directly or through the use of interlayers [1, 30, 77, 78]. It offers numerous points of interest, mostly the strength of the bonding line, which is equivalent to the base metals. The microstructure at the bonded area is precisely the same as the origin materials. Otherwise, this point of interest joining process requires a few entirely controlled conditions: spotless and smooth contacting surfaces which are free from oxides, and so forth, high temperature condition to advance diffusion process [79–81]. Then again, diffusion holding requires a considerably more joining time. Also, the equipment expenses are high because of the mix of high temperature and pressure in vacuum situations. This frequently constrains the part measurements, which might be unfavourable from a financial viewpoint [79].

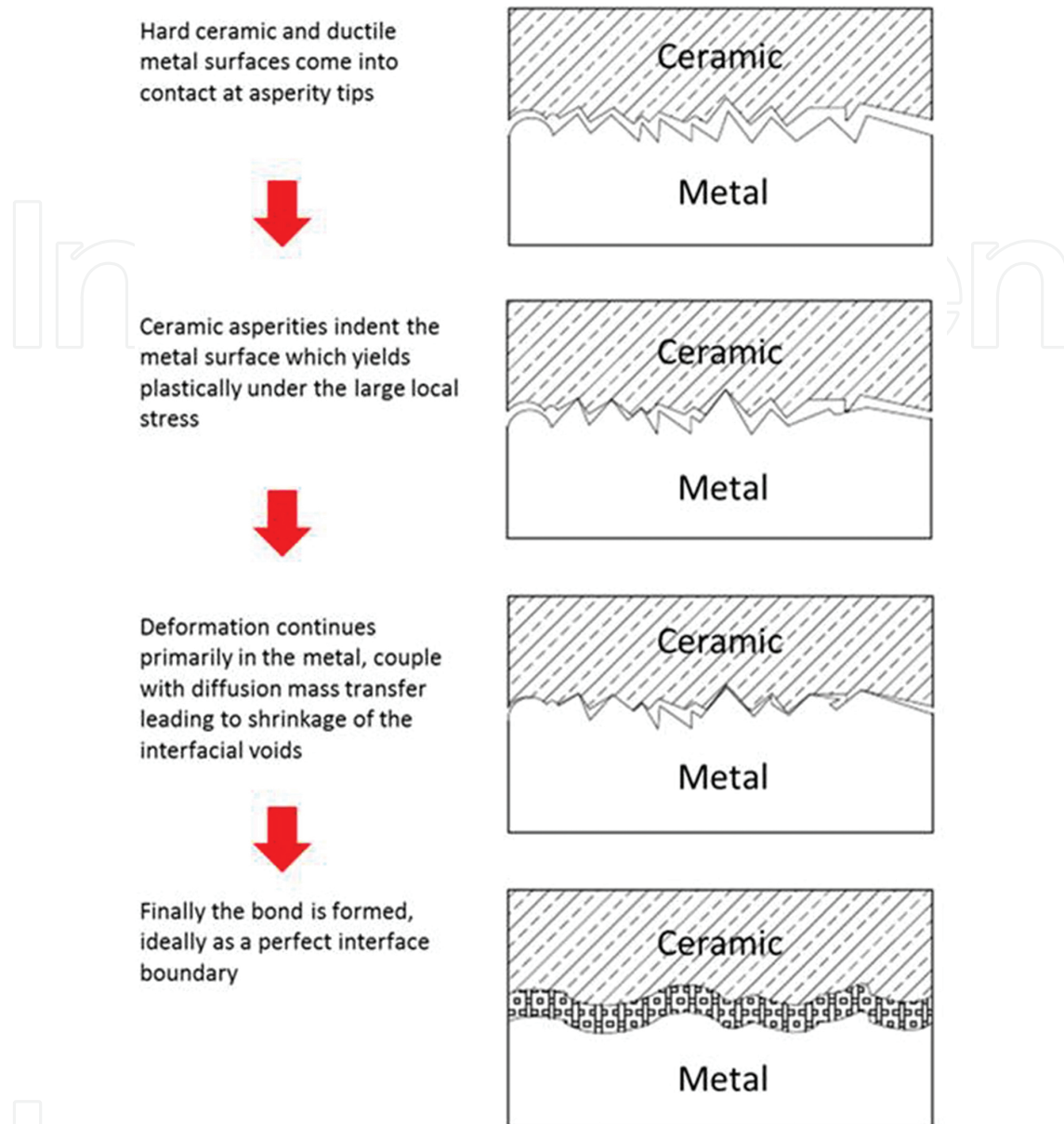

Figure 17. Sequence of events during metal-ceramic diffusion bonding [1].

The main process parameters which control the diffusion bonding process are temperature, time and pressure [82]. Process temperature parameter is the most important because of the way in a thermally activated process, a slight change in temperature will lead to a significant change in the kinetics of the process compared with other parameters, and almost all the mechanisms, including plastic deformation and disseminate sensitive to temperature [83]. The temperature chosen is typically in the region of 0.5–0.8 of the absolute melting temperature of the component having the lower melting point [84]. Hence, melting and melting related defects are avoided in diffusion bonding process [76, 79, 85].

Zhang et al. [86] have introduced the research and development of joining methods of ceramics to metals, especially brazing, diffusion bonding and partial transition liquid phase bonding.



From this article, the diffusion bonding is a technology to achieve compact joint by diffusion of atoms, even chemical reactions between materials or interlayer and materials. The diffusion of atoms in interface is carried out by several mechanisms, such as the replacement of near atoms, movement of clearance atoms and movement of vacancies, etc. The surface of the materials to be joined must be clean and flat (the roughness less than  $0.4\ \mu\text{m}$ ). Joining time can be a few hours at a mild temperature ( $0.6T_m$ ,  $T_m$  is melting point of metal to be joined), also can be several minutes at high temperature ( $0.8T_m$ ). Diffusion bonding can be achieved with inserted interlayer [87–92] or without interlayer [93, 94]. The diffusion interlayer can reduce the cracking, relax the thermal residual stress and improve the joining strength. The diffusion interlayer is produce of different element active to ceramics, such as titanium, niobium and zirconium etc.

Burger and Ruhle [95] studied the material transport mechanisms during the diffusion bonding for niobium (Nb) to alumina ( $\text{Al}_2\text{O}_3$ ). According to this chapter, the many different material transport phenomena may occur during the diffusion bonding process of a metal to a ceramic at high temperatures. The operating transport mechanisms depend on the selected combination of materials as well as on the bonding conditions. So from this work, the results were completed in which different faces in the niobium surface were bonded to a polished alumina surface. The niobium metal had either a very flat polished surface, or well-defined flaws of different shapes and dimensions and that were presented into the surface. The authors were found that the chemical reactions control the transport of materials and according to the conditions chosen for these experiments. As well as the interdependence of the diffusion joining of ceramics and metals requires that two couples have a near contact over the entire area of the joint interface. Even if all defects are detached, there may still be residual thermal stresses due to reaction layers, dislocations, facets, chemical gradients, dislocation arrangements, and precipitates formed during bonding. On Nb/ $\text{Al}_2\text{O}_3$  interfaces, thermal stresses are expected to be rather small since the thermal expansion coefficients of both materials are very near. No reaction layer was perceived.

### 5.3. Ceramic-metal laser welding

Laser welds bonding technique is a new kind of welding technology [96]. It has been developed as an alternative to adhesive bonding and laser welding. Laser welding has a small heat effect zone, which has little effect on the adhesive bonding area [97, 98]. The adhesive in the fusion zone decomposes during the laser welding process, which produces little effect on the properties of the joint. Thus, it can be assumed that laser welding and adhesive bonding hardly affect each other (**Figure 18**). The advantages of laser welding and adhesive bonding are both included in the laser weld bonding technique. The adhesive provides excellent stress distribution over large bonding areas and laser welding improves the peel resistance of adhesives. Thus, a laser weld bonding joint has better mechanical properties than either a laser welded or adhesive bonded joint alone. Laser welds bonding is a new hybrid technique that combines metallurgical joining, mechanical joining and chemical bonding [96].

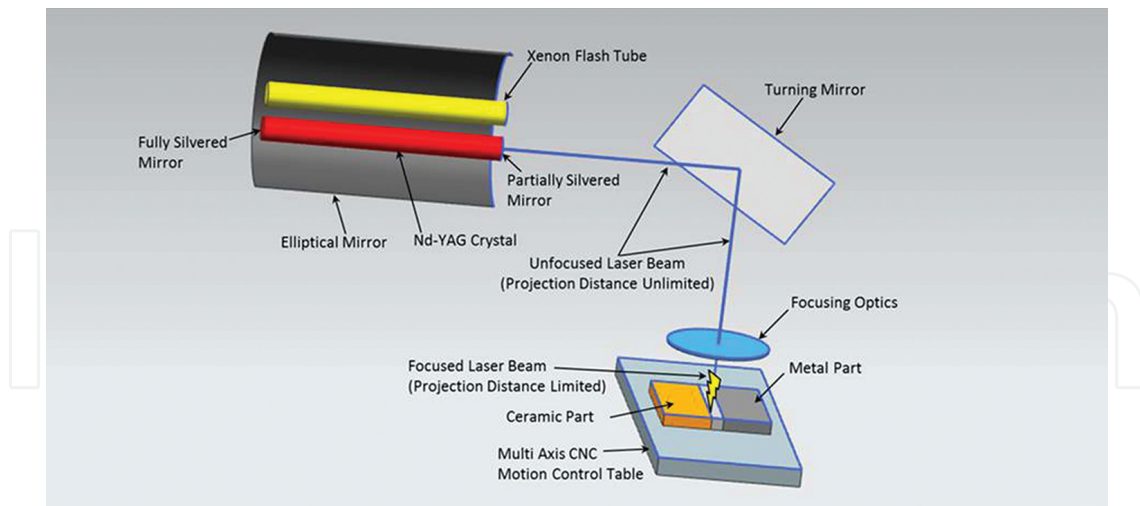

**Figure 18.** Schematic of the principle of laser welding process [99].

The development of more effective joining techniques for structural ceramics could also have a great impact on their use in mass-produced components. However, there are several challenges on component manufacturing by ceramic processing techniques and by the material themselves. Deformation densified ceramics to form complex shapes is practically impossible because most ceramic materials are brittle even at elevated temperatures. Moreover, ceramics are undesirable for mass production because of their high cost and machining difficulties. Effective ceramic joining techniques can play an important role in improving the reliability of ceramic structures as well [100]. Ceramics are very sensitive to flaws, due to the quality of raw materials used in their production and to the characteristics of various processing techniques, such as machining. Several techniques have been developed to join ceramics for structural application: brazing with filler metals; diffusion bonding; microwave joining; and the use of interface layers designed to form a thin transient liquid phase at a relatively low bonding temperature [97].

Many studies have been previously conducted on laser interactions with various metals and semiconductors, but few have been done in the processing of ceramics with lasers [101]. The advanced ceramic composite technology has offered more opportunity to fabricate complex structures of composite ceramic lasers, due to the availability of perfect inherent interface characteristics. One of the main problems in fusion welding of ceramics is to control cracking because of the residual thermal stresses. The result has been to give extra heating in a more extensive region around the zone of weld so that the net thermal slope of the extra heating and the joining source is presently adequately low so that no residual thermal stresses sufficiently high to cause cracking when reached [102]. This extra heating also allows the part to be heated and cooled very slowly enough to avoid thermal shock. In order to avoid weld cracking, and heated ceramic samples with radiant energy formed by halogen lamps, which have been collected by the indicators [103].

Exner and Nagel [104] have investigated about the laser welding of functional and constructional ceramics for microelectronics. They presented successful method of a laser welding



technology developed in the Laser Institute of Mittelsachsen (Germany). The investigations of alumina laser welding with a purity of 97% showed that in general the technology is suitable. Furthermore, it enables them to carry out the procedure without furnaces and in a natural atmosphere within only a few minutes. It was established, that the high quality of laser welding joints are achievable. Homogeneous structure and lead to no loss of power also, loss of tangible property is not known. The technology permits joining up to a thickness of 3.5 mm. Through using particular preheating it is conceivable to settle the material by metals. The shortest distance from the joining area is more than 25 mm. Implementation of the technology develops the application of ceramic dramatically. All the outstanding advantages of the laser material processing are useful: touchlessness, flexibility, precision and high velocity [104].

## 6. Conclusion

Advanced ceramics are key materials and are widely used in the electronics, fuel cell, sensor, insulator and Bioengineering fields. The joining of ceramics to metal is necessary and unavoidable in the miniature manufacturing field. Ceramic-metal joining processes and their resulting interfaces have been extensively studied over the years. New developments in the field have granted structural ceramics new horizons in applications involving adverse conditions and reliable materials. However, there still remain several unknown problems. Further experimental evidences could allow a more detailed understanding of the joining mechanism. A small size component (up to approximately 15 mm in diameter) can be joined by using a soft metal or a laminated interlayer for limited kinds of ceramics. How to join large size one with a metal is, however, still one of serious problems because the size dependence of residual stress is so severe. Since most of structural components will be used at elevated temperatures, the examinations on high temperature properties such as strength, oxidation, thermal expansion and thermal stress are required.

### Author details

Uday M.B.<sup>1\*</sup>, Ahmad-Fauzi M.N.<sup>2</sup>, Alias Mohd Noor<sup>1</sup> and Srithar Rajoo<sup>1</sup>

\*Address all correspondence to: ummb2008@gmail.com

1 Faculty of Mechanical Engineering, UTM Centre For Low Carbon Transport In Cooperation With Imperial College London, Institute For Vehicle Systems and Engineering, University of Technology Malaysia, Johor, Malaysia

2 School of Materials and Mineral Resources Engineering, Engineering Campus, Universiti Sains Malaysia, Penang, Malaysia

## References

- [1] Lemus-Ruiz J, Ceja-Cárdenas L, Bedolla-Becerril E, López-Morelos VH. Production, characterization, and mechanical evaluation of dissimilar metal/ceramic joints. *Nanocomposites with Unique Properties and Applications in Medicine and Industry*. InTech, Croatia. 2011:p. 205–24.
- [2] Loehman, R., *Characterization of Ceramics*, Momentum Press, 2009, p. 212–216.
- [3] Jadoon, A.K., *Employing reactive synthesis for metal to ceramic joining for high temperature applications*. *Journal of Materials Science*, 2004. 39(2): p. 593–604.
- [4] Palit, D., Meier, A., *Reaction kinetics and mechanical properties in the reactive brazing of copper to aluminum nitride*. *Journal of Materials Science*, 2006. 41(21): p. 7197–7209.
- [5] Park, J.-W., *A Framework for Designing Interlayers for Ceramic-to-Metal Joints*, Massachusetts Institute of Technology, 2002, p.18–24.
- [6] Wiese, J.L., *Strength of Metal-to-Ceramic Brazed Joints*, Massachusetts Institute of Technology, Department of Materials Science and Engineering, 2001, p.1–26.
- [7] Zhou, Y., *Microjoining and Nanojoining*, CRC Press, Inc, 2008, p.758–785.
- [8] Raić, K.T., *An estimate of  $Si_3N_4$  diffusion into Cu based filler metal*. *Ceramics International*, 2000. 26(1): p. 19–24.
- [9] Elssner, G., Petzow, G., *Metal/ceramic joining*. *ISIJ International*, 1990. 30(12): p. 1011–1032.
- [10] Somiya, S., *Handbook of Advanced Ceramics: Materials, Applications, Processing, and Properties*, Academic Press, 2013, p.23–65.
- [11] Lemus-Ruiz, J., Ceja-Cárdenas, L., Verduzco, J., Flores, O., *Joining of tungsten carbide to nickel by direct diffusion bonding and using a Cu–Zn alloy*. *Journal of Materials Science*, 2008. 43(18): p. 6296–6300.
- [12] Suganuma, K., *Recent advances in joining technology of ceramics to metals*. *ISIJ International*, 1990. 30(12): p. 1046–1058.
- [13] Khor KA, Wang M, Zhou W, Boey F, Srivatsan TS, editors., *Processing and Fabrication of Advanced Materials VIII*. World Scientific, 2001, p. 438–442.
- [14] Anderson, R., *Testing advanced ceramics*. *Advanced Materials and Processes*, 1989. 135: p. 31–36.
- [15] Mizuhara, H., Huebel, E., Oyama, T., *High-reliability joining of ceramic to metal*. *American Ceramic Society Bulletin (USA)*, 1989. 68(9), p.1591–1599.
- [16] Olofsson, J., *Friction and Wear Mechanisms of Ceramic Surfaces: With Applications to Micro Motors and Hip Joint Replacements*, Uppsala University, 2011, p.300–337.

- [17] Çelik, B., Distortion, Thermally Induced Stresses, Residual Joints, in *Welded*, in Institute of Natural and Applied Sciences, Cukurova University, 2009, p.1–29.
- [18] Lancaster, J.F., *Metallurgy of Welding*, William Andrew Pub., 1999, p.37–51.
- [19] Suganuma, K., Miyamoto, Y., Koizumi, M., *Joining of ceramics and metals*. Annual Review of Materials Science, 1988. 18(1): p. 47–73.
- [20] Uday, M.B., Ahmad-Fauzi, M.N., Zuhailawati, H., Ismail, A.B., *Effect of welding speed on mechanical strength of friction welded joint of YSZ–alumina composite and 6061 aluminum alloy*. Materials Science and Engineering: A, 2011. 528(13): p. 4753–4760.
- [21] Bellosi, A., Kosmac, T., Tomsia, A.P., *Interfacial Science in Ceramic Joining*. Vol. 58. 1998, Springer.
- [22] Suganuma, K., Okamoto, T., Koizumi, M., Kamachi, K., *Influence of shape and size on residual stress in ceramic/metal joining*. Journal of Materials Science, 1987. 22(10): p. 3561–3565.
- [23] Lemus-Ruiz, J., *Diffusion bonding of silicon nitride to titanium*, in *Department of Mining and Metallurgical Engineering*. 2000, McGill University: Montréal, Canada.
- [24] Hadian, A.M., *Joining of silicon nitride to silicon nitride and to molybdenum for high temperature applications*, in *Department of Mining and Metallurgical Engineering*. 1993, McGill University: Montreal, Canada.
- [25] Wunderlich, W., *The atomistic structure of metal/ceramic interfaces is the key issue for developing better properties*. Metals, 2014. 4(3): p. 410–427.
- [26] Nakahashi, M., *Joining of ceramics to metals (1): Interfacial reactions between ceramics and metals*. Welding international, 1996. 10(10): p. 765–770.
- [27] Saiz, E., Cannon, R.M., Tomsia, A.P., *High-temperature wetting and the work of adhesion in metal/oxide systems*. Annual Review of Materials Research., 2008. 38: p. 197–226.
- [28] Finnis, M., *The theory of metal-ceramic interfaces*. Journal of Physics: Condensed Matter, 1996. 8(32): p. 5811.
- [29] Passerone, A., Muoio, M.L., *Joining technology in metal-ceramic systems*. Materials and Manufacturing Processes, 2000. 15(5): p. 631–648.
- [30] Nascimento, R.M., Martinelli, A.E., Buschinelli, A.J.A., *Review article: recent advances in metal-ceramic brazing*. Cerâmica, 2003. 49: p. 178–198.
- [31] Abbas M. R., Uday M. B., Alias Mohd Noor, Norhayati Ahmad, and Srithar Rajoo. Microstructural evaluation of a slurry based Ni/YSZ thermal barrier coating for automotive turbocharger turbine application. Materials & Design. 2016, 109, p. 47–56.
- [32] Suganuma, K., *Reliability Factors in Ceramic/Metal Joining*. 1993, National Defense Academy Yokosuka, Japan.

- [33] Vila, M., Prieto, C., Zahr, J., Pérez-Castellanos, J.L., Bruno, G., Jiménez-Ruiz, M. Miranzo, P., Osendi, M.I., *Residual stresses in ceramic-to-metal joints: diffraction measurements and finite element method analysis*. Philosophical Magazine, 2007. 87(35): p. 5551–5563.
- [34] Ekwaro-Osire, S., Khandaker, M., Gautam, K., Accounting for high stress gradient by a modified Weibull failure theory. Journal of Engineering Materials and Technology, 2008. 130(1), p.1–8.
- [35] Joints, E.B., ed. Brazing Handbook, American Welding Society (AWS) C3 Committee on Brazing and Soldering, 2007, p.1–100.
- [36] Angelescu, D.E., Highly Integrated Microfluidics Design, Artech House Publishers, 2011, p.1–41.
- [37] Lugscheider, E., Tillmann, W., *Methods for brazing ceramic and metal-ceramic joints*. Material and Manufacturing Process, 1993. 8(2): p. 219–238.
- [38] Abbott Furnace Company, Brazing Process Fundamentals; Available from: <http://www.abbottfurnace.com/technology/brazing-fundamentals>
- [39] Schwartz, M.M., Brazing. ASM International, 2003, p.7–13.
- [40] Hunt, R.M., *Diffusion Bonding Beryllium to Reduced Activation Ferritic Martensitic Steel: Development of Processes and Techniques*. 2012, University of California, Los Angeles.
- [41] Belohlav, A., *Understanding brazing fundamentals*. Welding Journal (USA), 2000. 79: p. 11–14.
- [42] Blugan, G., Kuebler, J., Bissig, V., Janczak-Rusch, J., *Brazing of silicon nitride ceramic composite to steel using SiC-particle-reinforced active brazing alloy*. Ceramics International, 2007. 33(6): p. 1033–1039.
- [43] Churchill RJ, Varshney U, Groger HP, Glass JM, inventors; American Research Corporation Of Virginia, assignee. Laser brazing for ceramic-to-metal joining. United States patent US 5, 407, 119. 1995 Apr 18.
- [44] Bissig, V., Galli, M., Janczak-Rusch, J., *Comparison of three different active filler metals used for brazing ceramic-to-ceramic and ceramic-to-metal*. Advanced Engineering Materials, 2006. 8(3): p. 191–196.
- [45] Galli, M., Botsis, J., Janczak-Rusch, J., *Relief of the residual stresses in ceramic-metal joints by a layered braze structure*. Advanced Engineering Materials, 2006. 8(3): p. 197–201.
- [46] Nono, M., Barroso, J.J., Castro, P.J., *Mechanical behavior and microstructural analysis of alumina-titanium brazed interfaces*. Materials Science and Engineering: A, 2006. 435: p. 602–605.
- [47] M. Singh, T. Ohji, R. Asthana, S. Mathur, Ceramic Integration and Joining Technologies: From Macro to Nanoscale, Wiley.com, 2011, p.91–107.

- [48] Cazajus, V., Seguy, S., Lorrain, B., Weleman, H., Prat, C., Karama, M., Thermal stresses in a ceramic-metal composite after brazing process, ICSAM 2005, University "POLI-TEHNICA" of Bucharest, Romania, 15–17 Sept. 2005.
- [49] Cazajus, V., Lorrain, B., Weleman, H., Karama, M., *Residual stresses in ceramic metal assembly after brazing process*. Advances in Science and Technology, 2006. 45: p. 1543–1550.
- [50] Cazajus, V., Seguy, S., Weleman, H., Karama, M., *Residual stresses in a ceramic-metal composite*. Applied Mechanics and Materials, 2012. 146: p. 185–196.
- [51] Shirzadi, A., Zhu, Y., Bhadeshia, H.K.D.H., *Joining ceramics to metals using metallic foam*. Materials Science and Engineering: A, 2008. 496(1): p. 501–506.
- [52] Walker, C., Hodges, V., *Comparing metal-ceramic brazing methods*. Welding Journal, 2008. 87(10): p. 43–50.
- [53] Uday, M.B., et al., *An insight into microstructural evolution during plastic deformation in AA6061 alloy after friction welding with alumina-YSZ composite*. Mechanics of Materials, 2015. 91: p. 50–63.
- [54] Akbarimousavi, S., Goharikia, M., *Investigations on the mechanical properties and microstructure of dissimilar cp-titanium and AISI 316L austenitic stainless steel continuous friction welds*. Materials & Design, 2011. 32(5): p. 3066–3075.
- [55] Mousavi, S., Kelishami, A.R., *Experimental and numerical analysis of the friction welding process for the 4340 steel and mild steel combinations*. Welding Journal, 2008. 87(7): p. 178.
- [56] Özdemir, N., Sarsılmaz, F., Hasçalık, A., *Effect of rotational speed on the interface properties of friction-welded AISI 304L to 4340 steel*. Materials & Design, 2007. 28(1): p. 301–307.
- [57] Uday, M.B., Ahmad-Fauzi, M.N., Zuhailawati, H., Ismail, A.B., *Advances in friction welding process: a review*. Science and Technology of Welding & Joining, 2010. 15(7): p. 534–558.
- [58] Kumar, G.K., Kishore, K., GopalKrishna, P.V., Author, C., *Investigating the capabilities of medium duty lathe for friction welding*. Journal of Emerging Trends in Engineering and Applied Sciences (JETEAS), 2010. 1(1): p. 36–39.
- [59] Uday, M.B., Friction welding of 6061 aluminum alloy with YSZ-alumina composite for improved mechanical and thermal properties, in School of Materials and Mineral Resources Engineering, Engineering Campus, USM, 2013, p. 11–24.
- [60] Uday M.B., Ahmad-Fauzi, M.N., Ismail, A.B., Zuhailawati, H., *Effect of friction time on the properties of friction welded YSZ-alumina composite and 6061 aluminium alloy*. QScience Connect, 2013. (2013): p. 8.
- [61] Khan, I.A., Experimental and Numerical Investigation on the Friction Welding Process, Jawaharlal Nehru Technological University, 2012, p.208–155.



- [62] Yeoh, C., Shamsul, B.J., Ahmad, Z.A., *The effect of varying process parameters on the microhardness and microstructure of Cu-steel and Al-Al<sub>2</sub>O<sub>3</sub> friction joints*. Journal Teknologi, 2004. 41(A): p. 85–95.
- [63] Weiss, R., *Residual stresses and strength of friction welded ceramic/metal joints*. Welding Journal, 1998. 77(3): p. 115.s–122.s.
- [64] Weiss, R. Sassani, F., *Strength of friction welded ceramic–metal joints*. Materials Science and Technology, 1998. 14(6): p. 554–560.
- [65] Rombaut P, De Waele W, Faes K. Friction welding of steel to ceramic. In Sustainable Construction and Design 2011 (SCAD), Ghent University, Laboratory Soete, 2011, 2(3), p. 448–457.
- [66] Ikeuchi, K., Yamamoto, N., Tkahashi, M., Aritoshi, M., *Effect of interfacial reaction layer on bond strength of friction-bonded joint of Al alloys to steel*. Transactions of JWRI, 2005. 34(1): p. 1–10.
- [67] Davidge, R.W., Mechanical Behaviour of Ceramics, Cambridge University Press, 1979, p. 102–134.
- [68] Seli H, Awang M, Ismail AI, Rachman E, Ahmad ZA. Evaluation of properties and FEM model of the friction welded mild steel-Al6061-alumina. Materials Research. 2013 Apr; 16(2), p. 453–67.
- [69] Seli, H., Ismail, A.I.Md., Rachman, E., Ahmad, Z.A., *Mechanical evaluation and thermal modelling of friction welding of mild steel and aluminium*. Journal of Materials Processing Technology, 2010. 210(9): p. 1209–1216.
- [70] Seli, H., Rachman, E., Ahmad, Z.A., *Temperature modeling for friction welding process between ceramic and metal*. Advances in Science and Technology, 2011. 64: p. 115–124.
- [71] Noh, M.Z., Studies On The Performance Of Mild Steel-Alumina Joining Fabricated Via Friction Welding [TA470. Z21 2008 f rb], Universiti Sains Malaysia, 2008, p.10–57.
- [72] Noh, M.Z., Hussain, L.B., Ahmad, Z.A., *Alumina–mild steel friction welded at lower rotational speed*. Journal of Materials Processing Technology, 2008. 204(1): p. 279–283.
- [73] Uday, M., Ahmad-Fauzi, M., *Joint properties of friction welded 6061 aluminum alloy/YSZ–alumina composite at low rotational speed*. Materials & Design, 2014. 59: p. 76–83.
- [74] M. B. Uday, M. N. Ahmad-Fauzi, Z. Hussain, A. B. Ismail, Effect of deformation behavior on the grain size of the 6061 aluminum alloy joint with alumina by friction welding. in Applied Mechanics and Materials, Trans Tech Publ., 2011, p.97–102.
- [75] Kearns, W.H., Welding Processes-Resistance and Solid-State Welding and Other Joining Processes. Vol. 3. 1980, American Welding Society, p. 20–145.
- [76] Nicholas, M., Mortimer, D., *Ceramic/metal joining for structural applications*. Materials Science and Technology, 1985. 1(9): p. 657–665.

- [77] Quillen, B.G., Silicon Nitride Joining Using a Sr-Celsian-Based Glass Interlayer, DTIC Document, 1996, p.1–88.
- [78] Kumar, V., Studies on some glass sealants for solid oxide fuel cells, 2006, School of Physics and Materials Science, Thapar Institute Of Engineering And Technology, Deemed University.
- [79] Akselsen, O., *Diffusion bonding of ceramics*. Journal of Materials Science, 1992. 27(3): p. 569–579.
- [80] Rusnaldy, R., *Diffusion bonding: an advanced of material process*. Rotasi "Jurnal Teknik Mesin", 2001. 3(1): p. 23–27.
- [81] Garrett, B.R., Blank, G., Ranadive, A., Broad Applications of Diffusion Bonding, DTIC Document, 1966, p.1–176.
- [82] Balasubramanian, M., *Development of processing windows for diffusion bonding of Ti–6Al–4V titanium alloy and 304 stainless steel with silver as intermediate layer*. Transactions of Nonferrous Metals Society of China, 2015. 25(9): p. 2932–2938.
- [83] Sanfandila, P.T.Q., *Joining and characterizations of silicon nitride (Si<sub>3</sub>N<sub>4</sub>) to titanium (Ti) using a Cu-foil and Cu-Zn braze alloy*. Revista Mexicana de Física, 2009. 55(1): p. 25–29.
- [84] Kumar, S.S., et al., *Methodology to evaluate the quality of diffusion bonded joints by ultrasonic method*. Indian Journal of Engineering and Materials Sciences, 2009. 16(5): p. 331.
- [85] Jacobson, D.M., Humpston, G., Principles of Brazing, ASM International, 2005, Ch.1, p. 1–47.
- [86] Zhang, Y., Feng, D., He, Z.-y., Chen, X.-c., *Progress in joining ceramics to metals*. Journal of Iron and Steel Research, International, 2006. 13(2): p. 1–5.
- [87] Larker, R., Wei, L.Y., Loberg, B., Olsson, M., Johansson, S., *AEM investigation of ceramic/Incoloy 909 diffusional reactions after joining by HIP*. Journal of Materials Science, 1994. 29(16): p. 4404–4414.
- [88] Locatelli, M.R., Dalglish, B.J., Nakashima, K., Tomsia, A.P., Glaeser, A.M., *New approaches to joining ceramics for high-temperature applications*. Ceramics International, 1997. 23(4): p. 313–322.
- [89] Takaki, K., Fujimaki, Y., Takada, Y., Itagaki, M., Fujiwara, T., Ohshima, S., Oyama, K., Takahashi, I., Kuwashima, T., *A capacitor discharge technique with optimized energy for joining ceramics*. Vacuum, 2002. 65(3–4): p. 457–462.
- [90] Pan, H.H., Iijima, K., Liu, Y.J., Itoh, I., *Diffusion bonding of ZrB<sub>2</sub> ceramic and Al-Sn-Mg alloys at atmosphere*. Advanced Materials Research, 2011. 189: p. 3249–3252.
- [91] Janghorban, K., *Multilayer diffusion bonding of polycrystalline Al<sub>2</sub>O<sub>3</sub> to Al alloys containing Sr, Mg, and Si*. Iranian Journal of Science and Technology Transaction B-Engineering, 2009. 33(B3): p. 241–251.

- [92] Juan, W., Yajiang, L., Yansheng, Y., *Microstructural characterization in diffusion bonded TiC-Al<sub>2</sub>O<sub>3</sub>/Cr18-Ni8 joint with Ti interlayer*. Bulletin of Materials Science, 2006. 29(2): p. 155–158.
- [93] Martinelli, A.E., Drew, R.A.L., *Microstructural development during diffusion bonding of  $\alpha$ -silicon carbide to molybdenum*. Materials Science and Engineering: A, 1995. 191(1–2): p. 239–247.
- [94] Firmanto, H., Hussain, P., Mamat, O., *Reaction layers of the diffusion-bonded sialon and high-chromium steel*. Journal of Applied Sciences, 2011. 11(12): p. 1809–1814.
- [95] Burger, K., Rühle, M., *Material transport mechanisms during the diffusion bonding of niobium to Al<sub>2</sub>O<sub>3</sub>*. Ultramicroscopy, 1989. 29(1–4): p. 88–97.
- [96] Sun, X., Failure Mechanisms of Advanced Welding Processes, Woodhead Pub, 2010, p. 190–212.
- [97] Ion, J., Laser Processing of Engineering Materials: Principles, Procedure and Industrial Application, Butterworth-Heinemann, 2005, p.1–259.
- [98] Mikhailova, G., Mikhailov, B., Troitskii, A., *Laser welding of HTSC ceramics*. Laser Physics Letters, 2004. 1(10): p. 525–527.
- [99] Welding Miniature Devices, Decisions to make when choosing a joining process, Available from: <http://www.thefabricator.com/article/arcwelding/welding-miniature-devices> Decisions to make when choosing a joining process.
- [100] Lee, C.S., Zhang, X.F. Thomas, G., *Novel joining of dissimilar ceramics in the Si<sub>3</sub>N<sub>4</sub>-Al<sub>2</sub>O<sub>3</sub> system using polytypoid functional gradients*. Acta Materialia, 2001. 49(18): p. 3775–3780.
- [101] Kuramoto NO, Taniguchi HI., Transparent Ceramics, Springer, 2015, p.1–25.
- [102] De Paris, A., Robin, M., Fantozzi, G., *Welding of ceramics SiO<sub>2</sub>-Al<sub>2</sub>O<sub>3</sub> by laser beam*. Le Journal de Physique IV, 1991. 1(C7): p. C7-127–C7-129.
- [103] Riviere, C., Robin, M., Fantozzi, G., *Comparison between two techniques in laser welding of ceramics*. Le Journal de Physique IV, 1994. 4(C4): p. 4–4.
- [104] Exner, H., Nagel, A.-M., *Laser welding of functional and constructional ceramics for Microelectronics*. in *Optoelectronics' 99-Integrated Optoelectronic Devices*. 1999, International Society for Optics and Photonics.

