

# We are IntechOpen, the world's leading publisher of Open Access books Built by scientists, for scientists

6,900

Open access books available

186,000

International authors and editors

200M

Downloads

Our authors are among the

154

Countries delivered to

TOP 1%

most cited scientists

12.2%

Contributors from top 500 universities



WEB OF SCIENCE™

Selection of our books indexed in the Book Citation Index  
in Web of Science™ Core Collection (BKCI)

Interested in publishing with us?  
Contact [book.department@intechopen.com](mailto:book.department@intechopen.com)

Numbers displayed above are based on latest data collected.  
For more information visit [www.intechopen.com](http://www.intechopen.com)



---

# Progress in Investment Castings

---

Ram Prasad

Additional information is available at the end of the chapter

<http://dx.doi.org/10.5772/50550>

---

## 1. Introduction

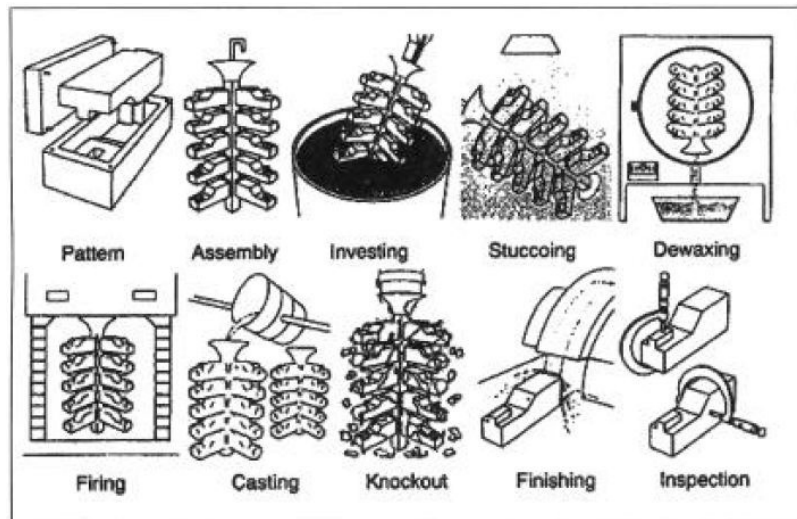
Certain basic elements in the earlier development of investment casting process, as well as many current advancements made to the process, some due to the rapid growth in technology, are described in this chapter.

Investment casting is often called 'lost wax' casting, and it is based on one of the oldest metal forming processes. The Egyptians used the process, some 5000 years ago, to make gold jewelry, as exact replica of many intricate shapes, cast in gold from artfully created beeswax patterns. In the investment casting process, a ceramic slurry is applied, or 'invested', around a disposable pattern, usually wax, and is allowed to harden to form a disposable casting mold. The wax pattern is 'lost', when it is melted out from the 'disposable' ceramic mold, which is later destroyed to recover the casting.

In investment casting, the ceramic molds are made by two different methods: the solid mold process and the ceramic shell process. The solid mold process is mainly used for dental and jewelry castings, currently has only a small role in engineering applications, and as such will not be covered in this chapter. The ceramic shell process has become the predominant technique for a majority of engineering applications, displacing the solid mold process.

The ceramic shell process is a precision casting process, uniquely developed and adapted to produce complex-shaped castings, to near-net-shape, and in numerous alloys. Continued advancements in materials and techniques used in the process, are driven and supported by R&D on many fronts, both in the industry as well as in many schools for foundry metallurgy. For instance, earlier research, funded by Rolls Royce Limited, UK, at the University of Birmingham, UK, investigating the feeding behavior of high temperature alloys has assisted in the development of optimal gating and feeding systems for investment castings, [1-6]. The influence of alloy and process variables on producing sound investment castings is detailed later in the chapter, under the section on the design of gating and feeding system.

The ceramic shell process, however, requires careful control during many steps or operations. The basic steps in the process, involving both materials and techniques are presented here, in the sequence illustrated in Fig.1.



**Figure 1.** Showing sequence of the steps in the investment casting process.

## 2. Pattern Materials

Pattern materials currently in use are waxes, and plastics, while other pattern materials are used sometimes, and for specific applications. Waxes, blended and developed with different compositions, are more commonly used, while use of plastic patterns, generally polystyrene, may sometimes be required, to produce thin-walled, complex-shaped castings, such as in aerospace integrally cast turbine wheels and nozzles.

### 2.1. Pattern Waxes

Waxes are mostly the preferred material for patterns, and are normally used, modified and blended with additive materials such as plastics, resins, fillers, antioxidants, and dyes, in order to improve their properties, [7].

Paraffins and microcrystalline waxes are the most widely used waxes, and are often used in combination, because their properties tend to be complementary.

Paraffin waxes are available in many controlled grades, with melting points ranging from 52 to 68 °C (126 to 156 °F). They are readily available in different grades, have low cost, high lubricity and low melt viscosity. Their usage is, however, limited because of high shrinkage and brittleness.

Microcrystalline waxes tend to be highly plastic and provide toughness to wax blends. Available in both hard, nontacky grades as well as soft, adhesive grades, they have higher melting points, and are often used in combination with paraffin.

Other waxes used include: Candelilla, a vegetable wax, which is moderately hard and slightly tacky. Carnauba wax is a vegetable wax with higher melting point, low coefficient of thermal expansion, and is very hard, nontacky and brittle. Beeswax is a natural wax, widely used for modeling, and in pattern blends, provides properties similar to microcrystalline waxes.

Fischer-Tropsch waxes are synthetic hydrocarbon waxes resembling paraffins, but are available in harder grades, with higher melting points. Ozocerite is a mineral wax sometimes used in combination with paraffin.

Waxes, in general, are moderately priced, and can easily be blended to suit different requirements. Waxes have low melting points and low melt viscosities, which make them easy to blend, inject, assemble into tree- or cluster-assemblies, and melt out without cracking the thin ceramic shell molds.

#### *2.1.1. Additives to Pattern Waxes*

Waxes with their many useful properties are, however, deficient in two practically important areas:

(a) Strength and rigidity especially required to make fragile patterns; and (b) Dimensional control, especially in limiting surface cavitation due to solidification shrinkage, during and after pattern injection. Additives are made to waxes to cause improvements needed in these two deficient areas.

The strength and toughness of waxes are improved by the addition, in required volumes, of plastics such as polyethylene, nylon, ethyl cellulose, ethylene vinyl acetate and ethylene vinyl acrylate.

Solidification shrinkage causing surface cavitation in waxes, is reduced to some extent by adding plastics, but is reduced to a greater extent by adding resins and fillers.

Resins suitable for this are: coal tar resins, various rosin derivatives, hydrocarbon resins from petroleum and tree-derived resins such as dammar, Burgundy Pitch, and the terpene resins. These resins have a wide range of softening points and varying viscosity at different temperatures. These factors must be considered while blending and using resins in pattern waxes.

Fillers are powdered solid materials, and are used more selectively in waxes than resins. This leads to the description of pattern waxes as being either filled or unfilled. Fillers have higher melting point and are insoluble in the base wax, thereby contributing to reduced solidification shrinkage of the mixture, in proportion to the amount used. Fillers that have been developed and used in pattern waxes include: spherical polystyrene, hollow carbon microspheres, and spherical particles of thermosetting plastic.

Several other additives can be used in pattern waxes to obtain additional properties. Antioxidants can be used to protect waxes and resins subject to thermal deterioration. Colors in the form of dyes are used to enhance appearance, to provide identification, and to facilitate inspection of injected patterns.

- Typical composition of unfilled waxes, with these additives, is in the following ranges:  
Waxes: 30-70%; Resins: 20-60%; Plastic: 0-20%; Other additives: 0-5%.

Filled waxes have similar base composition, and are normally added with 15 to 45% filler.

### 2.1.2. Factors for Pattern Wax Selection

Process factors while selecting and formulating wax pattern materials, that must be addressed are listed below, grouped with the material properties required or to be considered:

- Injection: Freezing range, softening point, ability to duplicate detail, setup time.
- Removal, handling, and assembly: Strength, hardness, rigidity, impact resistance, weldability.
- Dimensional control: Solidification shrinkage, thermal expansion, cavitation tendency.
- Shell mold making: Strength, wettability, and resistance to binders and solvents.
- Dewaxing and burnout: Softening point, viscosity, thermal expansion, and ash content.
- Miscellaneous: Availability, cost, ease of recycling, toxicity, and environmental factors.

## 2.2. Plastics

Plastic is the most widely used pattern material, next to wax. Polystyrene is usually used, because it is economical, very stable, can be molded at high production rates on automatic equipment, and has high resistance to handling damage, even in extremely thin sections.

Use of polystyrene is however limited, because of its tendency to cause shell mold cracking during pattern removal, and it requires more expensive tooling and injection equipment than for wax.

However, the most important application for polystyrene is for delicate airfoils, used in composite wax-plastic integral rotor and nozzle patterns, assembled using wax for the rest of the assembly.

## 2.3. Other Pattern Materials

Foamed Polystyrene has long been used for gating system components. It is also used as patterns with thin ceramic shell molds in a separate casting process known as Replicast Process.

Urea-based patterns, developed in Europe, have properties similar to plastics; they are very hard, strong and require high-pressure injection machines. Urea patterns have an advantage

over plastics: they can easily be removed, without stressing the ceramic shell, by simply dissolving in water, or an aqueous solution.

### 3. Production of Patterns

Patterns are usually produced by injecting pattern material in to metal dies, made with one or more cavities of the desired shape, in each die. Different equipments, with different operating parameters, have been developed to suit different pattern materials.

Wax patterns are injected at lower temperatures, (110 to 170 °F), and pressures, (40 to 1500 psi), in split dies using specially designed equipment. The wax injection equipment ranges from simple pneumatic units, to complex hydraulic machines, which can accommodate large dies, and at high injection pressures.

Polystyrene patterns are injected at higher temperatures, (350 to 500 °F), and pressures, (4 to 20 ksi), in hydraulic machines, normally equipped with water cooled platens that carry the die halves.

Advanced techniques have been developed currently to produce prototype, or experimental patterns, when only a few patterns are required. For such limited and/ or temporary usage of patterns, 'Rapid prototype patterns' are being produced in machines, with some utilizing advanced techniques such as SLS (selective laser sintering) or SLA (stereo lithography) and with special polymer material called photopolymers [ 8]. These techniques known alternatively as '3D-printing' or 'Additive- manufacturing', produce prototype patterns after building parts by depositing fine layers of various materials and using lasers only where necessary to achieve the finished shape, as defined by CAD. These patterns have been found to have favorable dewaxing response, resulting in substantially improved surface quality for investment cast prototypes in many alloys.

#### 3.1. Pattern Dies

Various pattern tooling options are available for waxes because of their low melting point and good fluidity. Many die materials are used, including: rubber, plastic, plaster, metal-filled plastic, soft lead-bismuth tin alloys, aluminum, brass, bronze, beryllium copper, steel or a combination of these. The selection is based on considerations of cost, tool life, delivery time, pattern quality, and production efficacy in available patternmaking equipment.

Plastic patterns usually require steel or beryllium copper tooling. Pattern dies made by machining use CNC (computer numerical controlled) machine tools and electric discharge machining. Alternatively, cast tooling made in aluminum, steel or beryllium copper is also used effectively. Wax can be cast against a master model to produce a pattern, which is then used to make an investment cast cavity for this type of cast tooling.



## 4. Pattern Assembly

Patterns for investment casting produced in dies are prepared for assembly in different ways. Large patterns are set-up and are processed individually, while small to medium size patterns are usually assembled into clusters for economy in processing. For example, pattern clusters of aircraft turbine blades may range from 6 to 30 parts. For small hardware parts, patterns set in clusters may range from tens to hundreds. Most patterns are injected with the gates.

However, large or complex parts are injected in segments, which are assembled into final form. The capacity of injection machines and the cost of tooling are important considerations. Gating components, including pour cups, gating and runner components forming trees or clusters are produced separately, and patterns assembled with these to produce the wax-tree or pattern cluster. Standard extruded wax shapes are often used for gating, especially for mock-up work. Preformed ceramic pour cups are often used in place of wax pour cups. Most assembly is done manually, with skilled personnel.

Wax components are assembled by wax welding, using hot iron or spatula, or a small gas flame. Wax at the interface between two components is quickly melted, and the components are pressed together until the wax solidifies. The joint is then smoothed over. A hot melt adhesive can be used instead of wax welding. Currently, laser welding units have been developed to provide improvements in assembling of wax components. Fixtures are essential to ensure accurate alignment in assembling patterns. Joints must be strong, and completely sealed with no undercuts. Care also must be taken to avoid damaging patterns or splattering drops of molten wax over the patterns being assembled.

Polystyrene pattern segments are assembled by solvent welding. The plastic at the interface is softened with solvent, and the parts are pressed together until bonded. However, polystyrene becomes very tacky when wet with solvent, and readily adheres to itself. Frequently, only one of the two halves needs to be wet. The assembly of polystyrene to wax is done by welding, with only the wax being melted.

Most assembly and setup operations are performed manually, but some automation is currently being introduced in some investment casting foundries. In one application, a robot is used to apply sealing compound in the assembly of patterns for different integrally cast nozzles, with each nozzle having, from 52 to 120 airfoils apiece.

### 4.1. Design of Pattern Tree or Cluster

The following preliminary requirements are considered essential:

- Providing a tree or cluster design that is properly sized and mechanically strong enough to be handled through the process
- Meeting all metallurgical requirements
- Providing test specimens for chemical or mechanical testing, when required.

Once these essentials are satisfied, other factors are adjusted to maximize profitability. Since the process is very flexible, foundries approach this goal in various ways. Some foundries prefer cluster design tailored to each individual part to maximize parts per cluster and metal usage. Others adopt standardized trees, or clusters, to facilitate handling and processing. When close control of grain is required, such as for equiaxed, directionally solidified columnar, or single crystal casting, circular clusters are often used to provide thermal uniformity during solidification in the casting process.

The design of the pattern tree or cluster is however, critical and important, since it can affect every aspect of the investment casting process. The design of the assembled pattern tree, or cluster critically impacts various stages of the investment casting process, as well as, in effectively meeting all the quality and metallurgical requirements of the final product.

As such, it is presented here in three parts, namely: (a) Basic design requirements, (b) Design of gating and feeding system, and (c) Use of computer solidification simulation software.

#### *4.1.1. Basic Design Requirements*

Contribution towards the final casting quality due to any specific design of the pattern tree, or pattern cluster needs to be carefully evaluated. Factors to be considered in the basic design of wax tree or cluster assembly include:

number of pieces processed at a time, ratio of metal poured to castings shipped, number of pieces assembled in each tree or cluster, ease of assembly, handling strength, ease of dipping or mold forming and drying, wax removal, shell removal, ease of cut off and finishing, and available equipment and processes at all stages.

Additional factors affecting metallurgical casting quality include: liquid metal flow in terms of tranquil, laminar flow or turbulence in flow, top fill versus bottom fill, gas or air entrainment, filling of thin sections, control of grain size and shape (when specified), effect on inducing favorable melt- temperature gradients, efficacy in feeding of shrinkage, ceramic bridging at added joints aggravating shrinkage, or the propensity for hot tears and cracks in casting sections.

#### *4.1.2. Design of Gating and Feeding System*

The critical aspects of tree/ cluster design are gating and risering, or feeding. Basic concepts of feeding sand castings, such as progressive solidification toward the riser or feeder, Chvorinov's rule and its extensions, solidification mode and feeding distance as a function of alloy, and section size also have been found to apply to investment casting, [1-3], [9]. The step-by-step procedure towards designing gating and feeding system is described, with two practical examples, at the Appendix. Feeding distances in hot investment molds are generally found to be longer than in sand molds. In investment castings, while separate feeders or risers are used sometimes, more often the gating system also performs the risering or feeding function. This applies specifically to numerous small parts that are commonly investment cast.



The use of wax trees or clusters permits great flexibility in the design of feeding systems. Wax clusters for process development are readily mocked up for trial. Extruded wax shapes are easily bent into feeders that can be attached to any isolated sections of the part that are prone for shrinkage. Once proved, they can be incorporated into tooling, if this is cost-effective. If not, they can be applied manually during tree or cluster assembly. This capability makes it practical to cast very complex parts with high quality. It also makes it feasible to convert fabrications assembled from large numbers of individual components into single-piece investment castings at substantial cost-savings.

#### *4.1.3. Use of Computer Solidification Simulation Software*

Considerable development efforts have been made to provide many solidification simulation models of value in investment casting production. Currently, alternative computer simulation software systems are available applying heat transfer models, based either on finite element or finite difference methods. These are being utilized on the shop floor in many larger foundries, especially in the design of gating and feeding systems, to determine effect of solidification conditions on alloy microstructure, and for accurate predictions of tooling dimensions. The use of simulation models plays a major role in the development of investment casting process for gas turbine blades, specified with equiaxed grains, DS (directionally solidified) columnar grains, or with single crystal, in many super alloys. Additionally, rapid advancements in the solidification software show continual improvement in the ability to predict accurately many grain defects that can occur in the production of directionally solidified, DS, or single crystal components.

## **5. Production of Ceramic Shell Molds**

Investment shell molds are made by applying a series of ceramic coatings to the pattern tree assemblies or pattern clusters. Each coating consists of a fine ceramic layer, with coarse ceramic 'stucco' particles embedded in its outer surface. The tree assembly or cluster is first dipped into a ceramic slurry bath, then withdrawn from the slurry, and manipulated to drain off excess slurry, and to produce a uniform layer. The wet layer is immediately stuccoed with coarser ceramic particles, either by immersing it into a fluidized bed of the particles, or by sprinkling or 'raining' on it the stucco particles from above.

The fine ceramic layer forms the inner face of the mold, and reproduces every detail, including the smooth surface of the pattern. It also contains the bonding agent, which provides strength to the structure. The coarse stucco particles serve to arrest further runoff of the slurry, help to prevent it from cracking or pulling away, provide keying or bonding between individual coating layers, and build up shell thickness faster.

Each coating is allowed to harden or set before the next one is applied. This is accomplished by drying, chemical gelling, or a combination of these. The operations of coating, stuccoing, and hardening are repeated a number of times, until the required shell thickness is achieved.

The final coat, often called a seal coat, is left unstuccoed, in order to avoid the occurrence of loose particles on the shell mold surface.

Various ingredients and preparation efforts required to make ceramic shell molds are described in the following section.

### 5.1. Refractories

Silica, zircon, alumina and various aluminum silicates are commonly used refractories for both slurry and stucco in making ceramic shell molds. Alumina is expensive, and as such used selectively, such as in directional solidification processes. Other refractories, such as graphite, zirconia and Ytria have been used with reactive alloys. Ytria is used in prime coats for casting titanium. Typical properties of refractories are listed in Table 1 [11].

*Silica* is generally used in the form of fused silica (silica glass). Fused silica is made by melting natural quartz sand and then solidifying it to form a glass, which is crushed and screened to produce stucco particles, and it is ground to a powder for use in slurries. The extremely low coefficient of thermal expansion of fused silica, Fig. 2, imparts thermal shock resistance to molds. Its ready solubility in molten caustic solutions provides a means of chemically removing shell material from areas of castings that are difficult to clean by other methods. Silica is sometimes used as naturally occurring quartz, expense of which is very low. However, its utility is limited because of its high coefficient of thermal expansion and by the high, abrupt expansion at 573 °C (1063 °F) accompanying its  $\alpha$ -to- $\beta$ -phase transition, causing excessive cracking of shell mold, if the mold is not fired slowly.

**Table 1** Nominal compositions and typical properties of common refractories for investment casting

Data are for comparison only, are not specifications, and may not describe commercial products.

Material	Nominal composition		Approximate theoretical density		Relative leachability (a)	Approximate melting point		PCE temperature (b)		pH	Color
	%	-form	g/cm <sup>3</sup>	lb/in. <sup>3</sup>		°C	°F	°C	°F		
<b>Aluminosilicates</b>											
42% ...	Al <sub>2</sub> O <sub>3</sub> -53 SiO <sub>2</sub>	Mixture	2.4-2.5	0.086 - 0.090	Poor	---	---	1750	3180	6.5-7.8	Gray to tan
47% ...	Al <sub>2</sub> O <sub>3</sub> -49 SiO <sub>2</sub>	Mixture	2.5-2.6	0.090 - 0.094	Poor	---	---	1760	3200	6.5-7.8	Gray to tan
60% ...	Al <sub>2</sub> O <sub>3</sub> -36 SiO <sub>2</sub>	Mixture	2.7-2.8	0.097 - 0.10	Poor	---	---	1820	3310	6.5-7.8	Gray to tan
70% ...	Al <sub>2</sub> O <sub>3</sub> -25 SiO <sub>2</sub>	Mixture	2.8-2.9	0.10 - 0.104	Poor	---	---	1865	3390	6.5-7.8	Gray to tan
73% ...	Al <sub>2</sub> O <sub>3</sub> -22 SiO <sub>2</sub>	Mixture	2.8-2.9	0.10 - 0.104	Poor	---	---	1820	3310	6.5-7.8	Gray to tan
Alumina	99% + Al <sub>2</sub> O <sub>3</sub>	Trigonal	4.0	0.144	Poor	2040	3700	---	---	8.5-8.9	White
Fused silica	99.5% SiO <sub>2</sub>	Typically 97% + amorphous	2.2	0.079	Good	1710	3110	---	---	6.0-7.5	White
Silica-quartz	99.5% SiO <sub>2</sub>	Hexagonal	2.6	0.094	Good	1710	3110	---	---	6.4-7.5	White to tan
Zircon	97% + ZrSiO <sub>4</sub>	Tetragonal	4.5	0.162	Moderate	2550	4620	---	---	4.7-7.0	White to tan

(a) **Poor**: slight reaction in hot concentrated alkali; **Good**: soluble to very soluble in hot concentrated alkali or hydrofluoric acid; **Moderate**: reacts with hot concentrated (b) **PCE**, Pyrometric cone equivalent. Source: "Ceramic Test Procedures" Investment Casting Institute, 1979 [Ref 11]

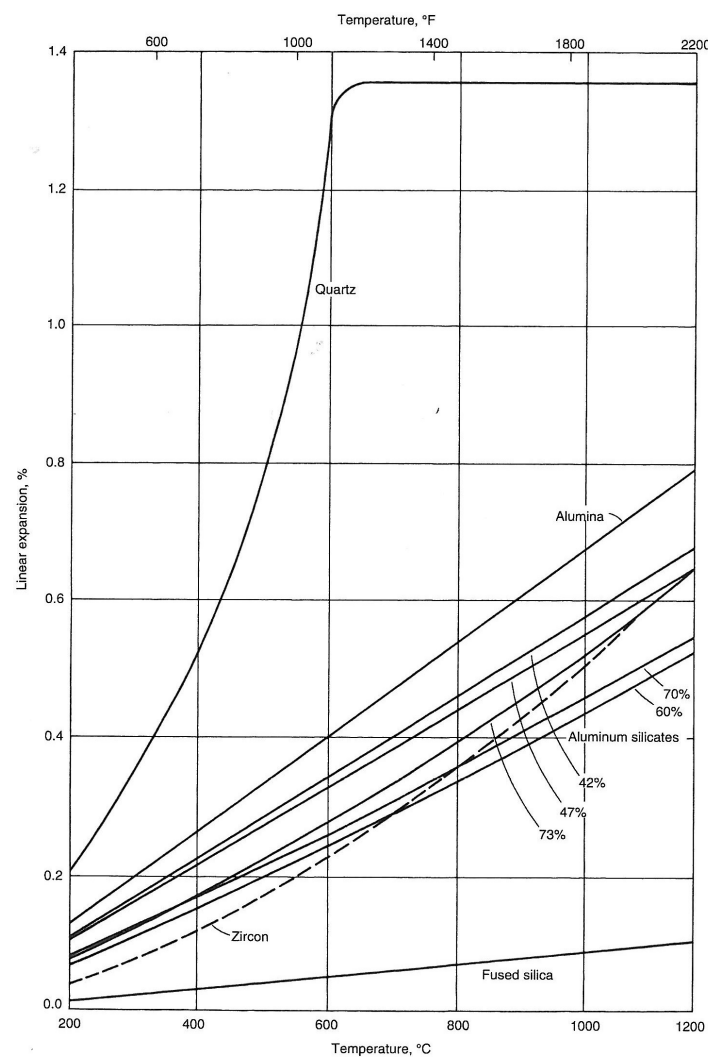
**Table 1.** Normal compositions and typical properties of common refractories for investment casting.

*Zircon* occurs naturally as a sand, and used in this form as a stucco. Its primary advantages are high refractoriness, resistance to wetting by molten metals, and round particle shape. Use of zircon is generally limited with prime coats, as it does not occur in sizes coarse

enough for stuccoing backup coats. It is ground to powder for use in slurries, often in conjunction with fused silica and aluminosilicates.

*Aluminum silicates* are generally composed of stable compound, mullite ( $\text{Al}_2\text{O}_3 \cdot 2\text{SiO}_2$ ) with some free silica, which is usually in the form of silica glass. They are made by calcining fire-clays, to produce different levels of mullite, (which contains 72% alumina) and free silica. Refractoriness and cost increase with alumina content. Fired pellets are crushed or ground and carefully sized to produce a range of powder sizes for use in slurries, and granular materials for use as stuccos.

*Alumina*, produced from bauxite ore by the Bayer process, is more refractory than silica or mullite, and is less reactive toward many alloys. However, its use is primarily confined to superalloy casting.



**Figure 2.** Linear thermal expansion of refractories commonly used for investment casting [11].

## 5.2. Binders

The commonly used binders include colloidal silica, hydrolyzed ethyl silicate and sodium silicate.

*Colloidal silica* is most widely used. It consists of a colloidal dispersion of spherical silica particles in water. It is an excellent general purpose binder. Its main disadvantage is that its water base makes it slow drying, especially in inaccessible pockets or cores.

*Ethyl silicate* which has no bonding properties is converted to ethyl silicate binder by hydrolysis, a reaction with water carried out in ethyl alcohol, using acid catalyst such as hydrochloric acid.

Ethyl silicate, with its alcohol base, dries much faster than colloidal silica. Ethyl silicate slurries are readily gelled after rapid dripping cycles, by exposure to an ammonia atmosphere. Use of this binder is however, rapidly declining, since it is much more expensive, and poses fire and environmental hazards.

*Liquid sodium silicate* solutions are sometimes used where a very inexpensive binder is desired. They have poor refractoriness, which limits their application.

*Other Binders:* The operation of directional solidification and single crystal processes, which subject the mold to high temperatures, for longer times, along with the introduction of more reactive superalloys, has led to the development of more refractory binders, such as colloidal alumina and colloidal zirconia binders. Both these binders, however, are inferior to colloidal silica in room temperature bonding properties.

## 5.3. Other Ceramic Shell Constituents

*Wetting Agents.* Slurries generally contain wetting agents, in addition to the refractory and the binder, to promote wetting of the pattern or prior slurry coats. Wetting agents such as sodium alkyl sulfates, sodium alkyl aryl sulfonates, or octyl- phenoxy polyethoxy ethanol, are generally used in amounts of 0.03 to 0.3% by weight of the liquid. Wetting agents are sometimes omitted from ethyl silicate alcohol slurries and from water based back-up slurries.

*Antifoam Compounds.* Where wetting agents are used, especially in prime coats, an antifoam compound is included to suppress foam formation and to permit air bubbles to escape. Commonly used defoamers are aqueous silicone emulsions and liquid fatty alcohols such as *n*-octyl alcohol. These are effective in low concentrations of 0.002 to 0.10%, based on the liquid weight.

*Other Constituents.* Nucleating agents, or grain refiners, which are refractory cobalt compounds such as aluminates, silicates, and oxides are added to the prime slurry (in amounts from 0.5 to 10% by weight of the slurry) for equiaxed superalloy castings, where close control of grain size is required. Organic film formers are sometimes used to improve green strength. Small additions of clay have been used to promote coating characteristics.

#### 5.4. Slurry Preparation

Compositions of the slurry, which are usually proprietary, are based on the particular refractory powder and the type of binder. Slurry composition is generally in the following broad range:

- Binder solids: 5 -10%
- Liquid (from binder or added) : 15 – 30%
- Refractory powder: 60-80%

Slurries are prepared by adding refractory powder to binder liquid, using agitation to break up agglomerates, remove any air entrainment. Stirring is continued until viscosity falls to its final level before the slurry is put to use. Continued stirring is also required in production to keep the powder from settling out of suspension. Either rotating tanks with baffles or propeller mixers are used for this purpose.

*Control procedures* for slurries vary considerably among foundries. The most prevalent controls are the measurement of the initial ingredients, slurry temperature, density, pH and viscosity. Viscosity is measured with a No.4 or 5 Zahn cup, or a Brookfield type rotating viscometer. Properties of the finished ceramic shells that are monitored include: weight, modulus of rupture (green and fired), and permeability.

#### 5.5. Pattern Tree or Cluster Preparation

Before dipping, pattern trees or clusters are usually cleaned to remove injection lubricant, loose pieces of wax, or dirt. Cleaning is accomplished by rinsing the pattern clusters in solution of wetting agent, or a suitable solvent that does not attack the wax. The trees, or clusters, are usually allowed to return to room temperature and dry, before dipping.

#### 5.6. Coating and Drying

Dipping, draining, and stuccoing of clusters are carried out manually, robotically, or mechanically. Foundries are increasingly using robots in order to heighten productivity, to process larger parts and clusters, and to produce more uniform coatings. When robots are introduced, they are often programmed to reproduce actions of skilled operators. Dedicated mechanical equipment can sometimes operate faster, especially with standardized clusters.

Most dipping is done in air, but dipping under vacuum has been found, in some limited applications, very effective for coating narrow passageways and for eliminating air bubbles.

The cleaned wax cluster is dipped into the prime slurry and rotated. It is then withdrawn and drained over the slurry tank with suitable manipulation to produce a uniform coating. Next the stucco particles are applied by placing the cluster in a stream of particles falling from an overhead screen in a rainfall sander, or by plunging the cluster into a fluidized bed of the particles. In the fluidized bed, the particles behave as a boiling liquid, because of the action of pressurized air passing through a porous plate in the bottom of the bed.



Generally, prime slurries contain finer refractory powder, are used at a higher viscosity, and are stuccoed with finer particles than the backup coats. These characteristics provide a smooth surfaced mold, capable of resisting metal penetration.

Backup coats are formulated to coat readily over the prime coats (which may be somewhat porous and absorbent), to provide high strength, and to build up the required thickness with a minimum number of coats. The number of coats required is related to the size of the clusters and the metal weight to be poured. It may range from 5 for small clusters, to 15 or more for large ones. For most applications, the number ranges from 6 to 9.

Between coats, the slurries are hardened by drying or gelling. Air drying at room temperature with circulating air of controlled temperature and humidity is the most common method. Drying is usually carried out on open racks or conveyors, but cabinets or tunnels are sometimes used.

Drying is complicated by the high thermal expansion and contraction characteristics of waxes. If drying is too rapid, the chilling effect causes the pattern to contract, while the coating is still wet and unbonded. Then, as the coating is developing strength and even shrinking, the wax begins to expand, as the drying rate declines and it regains temperature. This can actually crack the coating. Therefore, to prevent this, relative humidity is normally kept above 40%, usually at a recommended value of 50%.

## 6. Ceramic Cores

Ceramic cores are widely used in investment castings to produce internal passageways in castings; and cores are either self-formed or preformed.

- a. *Self-formed cores* are produced during the mold building, with the wax patterns already having corresponding openings. Metal pull cores in pattern tooling are used for simple shapes, while soluble cores for other shapes are made and placed in the pattern tooling, and the pattern injected around them. The soluble core is then dissolved out in a solution that does not affect the wax pattern, such as an aqueous acid. Citric acid is used commonly.
- b. *Preformed cores* are required when self-formed cores can not be used, and are produced by a number of ceramic forming processes. Simple tubes and rods are commonly extruded from silica glass. Many cores are made by injection molding of fine ceramic powder with a suitable organic binder into steel dies and subjecting the cores to a two stage heat treatment. In the second stage, the core is sintered to its final strength and dimensions.

Preformed cores are normally used by placing in pattern die and injecting wax around them. Since cores expand differently than the shell molds, due to their differences in composition, cores must be provided with slip joints in the mold [12].



## 7. Removal of Pattern

Pattern removal is the operation that subjects the shell mold to the most stresses, since the thermal expansion of waxes are many times those of refractories used for molds. When the mold is heated to liquefy the wax, this expansion differential leads to enormous pressure that is capable of cracking, or even destroying the mold. In practice, this problem is effectively circumvented by heating the mold extremely rapidly from the outside in. This causes the surface layers of wax to melt very quickly, before the rest of the pattern can heat up appreciably. This molten wax layer either melts out of the mold or soaks into it, thus providing the space to accommodate the expansion as the remainder of the wax is heated. Melt-out tips are sometimes provided, or holes are drilled in the shell to relieve wax pressure.

Even with these techniques, the shell is subject to high stress. To get the shell as strong as possible, it should be thoroughly dried before dewaxing. Shells are subject to 16 to 48 h of extended drying after the last coat, sometimes enhanced by the application of vacuum or extremely low humidity. Two methods have been developed to implement the surface melting concept: autoclave dewaxing and high temperature flash dewaxing.

- *Autoclave dewaxing* is the most widely used method. Saturated steam is used in a jacketed vessel, with a steam accumulator to ensure rapid pressurization. Autoclaves are equipped with a sliding tray to accommodate a number of molds, a fast acting door with a safety lock, and an automatic wax drain valve. Operating pressures of approximately 550 to 620 kPa (80 to 90 psig) are reached in 4 to 7 s. Molds are dewaxed in approximately 15 min. or less. Wax recovery is good. Polystyrene patterns cannot be melted out in the autoclave, but require flash dewaxing.
- *Flash dewaxing* is carried out by inserting the shell into a hot furnace at 870 to 1095 °C (1600 to 2000 °F). The furnace is equipped with an open bottom so that wax can fall out of the furnace as soon as it melts. Some of the wax begins to burn as it falls, and even though it is quickly extinguished, there is greater potential for deterioration than with an autoclave. Nevertheless, wax from this operation can be reclaimed satisfactorily. Flash dewaxing furnaces must be equipped with an afterburner in the flue or some other means to prevent atmospheric pollution.

Polystyrene patterns are readily burned out in flash dewaxing. However, polystyrene can cause extensive mold cracking, unless it is embedded in wax in the pattern (as in integral nozzle patterns), or unless the polystyrene patterns are very small.

- *Hot liquid dewaxing* has found some use among smaller companies seeking to minimize capital investment. Hot wax at 177 °C (350 °F) is often used as the medium, while other liquids can also be used. Cycles are longer than for autoclave and flash dewaxing, and there is potential fire hazard.

## 8. Mold Firing and Burnout

Ceramic shell materials are fired to remove moisture (free and chemically combined), to burn off residual pattern material and any organics used in the shell slurry, to sinter the ceramic, and to preheat the mold to the temperature required for casting. In some cases, these are accomplished in a single firing. Other times, preheating is performed in a second heating, after the mold is cooled down, inspected and repaired if necessary. Cracked molds can be repaired with ceramic slurry or special cements. Many molds are wrapped with a ceramic-fiber blanket at this time to minimize the temperature drop that occurs between the preheat furnace and the casting operation, or to provide better feeding by insulating selected areas of the mold. Gas fired furnaces are used for mold firing and preheating, except for molds for directional solidification processes, which are preheated in the casting furnace with induction or resistance heating. Batch and continuous pusher-type furnaces are most common, but some rotary furnaces are also in use.

Burnout furnaces operate with temperatures between 870 and 1095 °C (1600 and 2000 °F), and have some 10% excess air provided to ensure complete combustion of organic materials. Preheat temperatures vary depending on part configuration and the alloy to be cast. Common ranges are: 150 to 540 °C (300 to 1000 °F) for aluminum alloys, 425 to 870 °C (800 to 1600 °F) for many copper base alloys, and 870 to 1095 °C (1600 to 2000 °F) for steels and superalloys. Molds for the directional solidification process are preheated above the liquidus temperature of the alloy being cast.

## 9. Melting and Casting

Different types of equipment are currently in use for melting, and support different casting methods adopted.

### 9.1. Melting Equipment

*Coreless type Induction furnaces* are used with capacities ranging from 15 to 750 lb., with normal melting rates of 3 lb/min. They are usually tilting models, and can be employed for melting in air, inert atmosphere or vacuum. They are extensively used for melting steel, iron, cobalt and nickel alloys, and sometimes copper and aluminum alloys. *Gas-fired crucible furnaces* are used for aluminum and copper alloy castings, while *electrical resistance furnaces* are sometimes preferred for aluminum casting, since they help reduce hydrogen porosity. The crucibles typically used are magnesia, alumina and zirconia, which are made by slip casting, thixotropic casting, dry pressing, or isostatic pressing. Magnesium alloys can be melted in gas-fired furnaces using low-carbon steel crucibles.

*Consumable-electrode vacuum arc skull furnaces* are used for melting and casting titanium.

*Electron beam melting* has been used in Europe as an alternative to vacuum arc melting for casting titanium [13], and in the United States, for melting superalloys for directionally solidified and single crystal casting [14].

## 9.2. Casting Methods

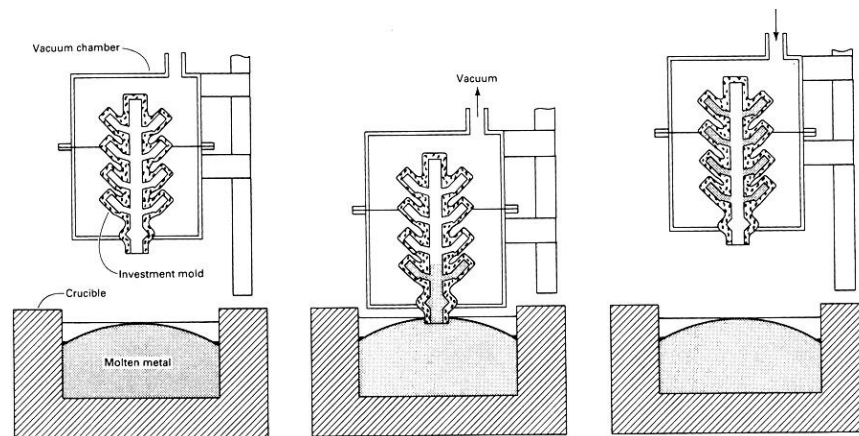
Both air and vacuum casting methods are used in investment casting. There is some use of rammed graphite molds in vacuum arc furnaces for casting titanium. Most castings are gravity poured.

- *Air casting* is used for many investment-cast alloys, including aluminum, magnesium, copper, gold, silver, platinum, all types of steel, ductile iron, most cobalt alloys, and nickel-base alloys that do not contain reactive elements. Zinc alloys, gray iron and malleable iron are usually not investment cast for economic reasons.
- *Vacuum casting* provides cleaner metals with superior properties and is used for alloys that can not be cast in air, such as the  $\gamma'$ -strengthened nickel base alloys, some cobalt alloys, titanium and the refractory metals. Batch and semicontinuous interlock furnaces are normally used.

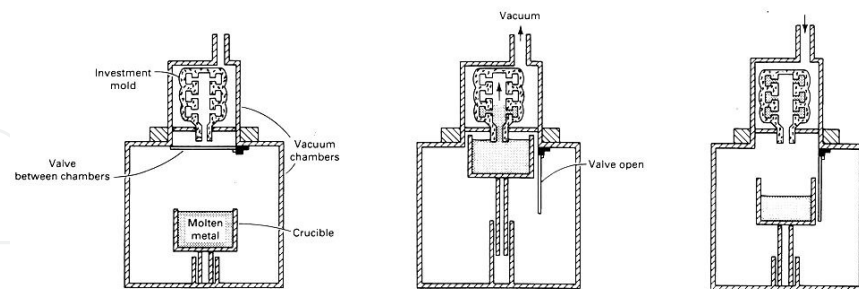
A major advantage of investment casting is its ability to cast very thin walls, due to the use of hot mold. This advantage is further enhanced by specific casting methods, such as vacuum-assist casting, pressurized casting, centrifugal casting and countergravity casting.

- In *vacuum-assist* casting, the mold is placed inside an open chamber, which is then sealed with a plate and gaskets, leaving only the mold opening exposed to the atmosphere. A partial vacuum is drawn within the chamber and around the mold. The metal is poured into the exposed mold opening, and the vacuum serves to evacuate air through the porous mold wall and to create a pressure differential on the molten metal, both of which help to fill delicate detail and thin sections.
- In *pressurized casting*, rolover furnaces are pressurized for the same purpose. The hot mold is clamped to the furnace-top with its opening in register with the furnace opening, and the furnace is quickly inverted to dump the metal into the mold, while pressure is applied using compressed air or inert gas.
- *Centrifugal casting* uses the centrifugal forces generated by rotating the mold to propel the metal and to facilitate filling. Vacuum arc skull furnaces discharge titanium alloy at a temperature just above its melting point, and the centrifugal casting is usually needed to ensure good filling. Dental and jewelry casting use centrifugal casting to fill thin sections and fine detail.
- *Countergravity casting* assists in filling thin sections, by applying a differential pressure between molten metal and the mold. This technique developed for over 30 years, works effectively in air or under vacuum, for air melted and vacuum melted alloys, to produce castings in aluminum and nonferrous alloys, many types of steels and superalloys, in weights from a few grams to 20 kg (44 lb) [15].

- *Countergravity Low-Pressure Air (CLA) Process* has the preheated shell mold, with an extended sprue, placed in a chamber above the melt surface of an air melted alloy, as described in Fig. 3. The sprue is lowered to below the melt surface, vacuum applied to mold chamber to cause controlled filling of the mold. The vacuum is released after castings and in-gates solidify, causing molten metal in the central sprue to return to the melt crucible, for use in the next cycle. Besides substantial savings in alloy usage and improved gating efficiency, the other benefits from the process include improved casting quality with reduced dross and slag inclusions.



**Figure 3.** Schematic of the operations in the CLA process. (a) Preheated investment shell mold placed in the casting chamber. (b) Mold is lowered to the filling position, and vacuum is applied. (c) After casting and in-gates have solidified, vacuum is released, and all of the central sprue flows back into the melt.



**Figure 4.** Schematic showing steps in the CLV process. (a) Metal is melted in vacuum, hot mold introduced into upper chamber, which is then evacuated. (b) Both chambers are flooded with argon, valve between the chambers is opened, and fill pipe enters the melt. Vacuum is applied to the upper chamber to draw metal upward. (c) The vacuum is released after the parts are solidified, and the remaining molten metal in the gating system returns to the crucible.

- *Countergravity Low-Pressure Vacuum (CLV) Process* is similar to CLA process, and as described in Fig. 4, has the crucible in a vacuum chamber for vacuum melted alloys such as in nickel-base and cobalt-base superalloys.

## 10. Postcasting Operations

Post casting operations represent a significant portion, often 40 to 60%, of the cost of producing investment castings. A standard shop routing is provided for each part, and large savings can be realized by specifying the most cost-efficient routing. For example, it is often cost-effective to scrap early to avoid wasting finishing time, even if this means including an extra inspection operation. Alternative methods may be available for performing the same operation, and the most efficient one should be selected. The actual sequence in which operations are performed can be important. Some specifications require verification of alloy type, and this is done before parts are removed from the cluster.

- a. *Knockout.* Some shell material may spall off during cooling, but a good portion usually remains on the casting and is knocked off with a vibrating pneumatic hammer or by hand. Brittle alloys require special attention. Part of the prime coat sometimes remains adhered to the casting surface, and the bulk shell material may remain lodged in pockets or between parts. This is removed in a separate operation, usually shotblasting. Clusters are hung on a spinner hanger inside a blasting cabinet, or are placed on a blasting table. If cores are to be removed in a molten caustic bath, the entire cluster can be hung in the bath, and the remaining refractory can be removed along with the cores. High-pressure water (6 to 10 ksi) is sometimes used instead of mechanical knock out, especially for aluminum and other nonferrous alloy parts.
- b. *Cutoff.* Aluminum, magnesium, and some copper alloys are cut off with band saws. Other copper alloys, steel, ductile iron, and superalloys are cut off with abrasive wheels operating at about 3500 rpm. Torch cutting is sometimes used for gates that are inaccessible to the cutting wheel. Some brittle alloys can be readily tapped off with a mallet. Some steel and ductile iron parts can be cutoff after soaking parts in frozen liquid nitrogen (-320 °F). Gates are to be properly notched for these two cutoff techniques. Shear dies have also been used to remove castings from standardized clusters. Following cutoff, gate stubs are ground flush and smooth using abrasive wheels, and small hand grinders equipped with mounted stones.
- c. *Core Removal.* Cores can be removed by abrasive or water blasting. If blasting can not be used, the cores can be dissolved out, using molten caustic bath (sodium hydroxide) at 900 to 1000 °F, or a boiling solution of 20 to 30% sodium hydroxide or potassium hydroxide in an open pot, or in high-pressure autoclave.
- d. *Heat Treatment.* Air or vacuum heat treatments are performed extensively as needed to meet property requirements. Before they are heat treated, single-crystal castings must be handled very carefully to avoid recrystallization during subsequent heat treatment.
- e. *Abrasive Cleaning.* Blast cleaning is used to remove scale resulting from core removal or heat treatment, using pneumatic and centrifugal blasting machines. Steel or iron grit or shot, and silica, or alumina sand are commonly used.



- f. *Other Postcasting operations.* Hot isostatic pressing (HIP) is being increasingly adopted to eliminate porosity, and to improve properties especially for titanium, and used selectively for steel, aluminum, and superalloys.

Machining is often performed on investment castings, normally confined to selected areas requiring closer dimensions. Broaching, coining and abrasive grinding are used to improve dimensional accuracy. Straightening of investment castings, heated usually, is performed when required, either manually or using hydraulic presses, with suitable fixtures.

Chemical finishing treatments are also used, in applications such as: acid pickling to remove scale, passivation treatment for stainless steel, chemical milling to remove  $\alpha$ -case on titanium, and chemical treatment to apply a satin finish to aluminum or to polish stainless steel.

## 11. Inspection and Testing

(a) *Alloy Type Test.* This test is often an alloy verification test, and is conducted on the tree or cluster before cutoff. A spectrometer or X-ray analyzer is used to verify that the correct alloy has in fact been poured.

(b) *Visual inspection.* An early visual inspection is essential so that obvious scrap does not get passed on to expensive finishing or inspection operations. Some commercial parts require only visual inspection.

(c) *Fluorescent Penetrant Inspection* is extensively used for nonmagnetic alloys. It can also be used for magnetic alloys, but a magnetic penetrant is generally specified instead. This test detects defects on, or open to the surface, such as porosity, shrinkage, cold shuts, inclusions, dross, and cracks of any origin (hot tears, knockout, grinding, heat treat, straightening). In this technique, the surface is cleaned and a liquid penetrant with a low surface tension and low viscosity is applied, and is drawn into the defects by capillary action. Excess liquid is wiped away, a developer is applied that functions as a blotter to draw the liquid out, and the area is examined visually in a dark enclosure under black (ultraviolet) light, which reveals defects that cannot be detected visually.

(d) *Magnetic Particle Inspection* detects similar defects, but is preferred for use on ferromagnetic alloys. The method involves surface preparation, magnetization of the casting, and application of either a liquid suspension of magnetic particles (wet method) or fine magnetic particles (dry method). The presence of defects causes a leakage field that attracts the magnetic particles and causes them to cling to the defect and define its outline. Colored particles and fluorescent particles (for viewing under black light) are available and can be used as required.

(e) *X-ray Radiography* is used to detect such internal defects as shrinkage, gas porosity, dross, inclusions, broken cores, and core shift. Many parts receive 100% inspection, while others are inspected according to a specified sampling plan. Even when not specified, X-ray inspec-



tion is used as a foundry control tool to monitor process reliability, to establish a satisfactory gating and feeding system, and to troubleshoot foundry problems. It is sometimes used to examine wax patterns containing delicate ceramic cores, to ensure that the cores were not broken during the pattern injection operation.

(f) *Miscellaneous Inspection Methods:*

*Hardness testing* is widely used to verify response of castings to heat treatment. Chemical analysis is generally controlled through the use of certified master heats. Mechanical properties are determined on separately cast test bars or test specimens mounted on production clusters. Specimens machined from castings are used for process development and periodic audits.

*Grain size* is regularly checked on many equiaxed castings, following chemical or electrolytic etching, and often as a part of process development effort. Electrolytic etching is also used for examining and detecting grain defects in directionally solidified and single crystal castings.

The orientation of single crystal castings is determined by *Laue back-reflection x-ray diffraction*.

*Pressure tightness* tests on investment castings are conducted for a variety of engineering and other applications.

*Dimensional inspection* ranges from manual checks with a micrometer or simple go/no-go gages, to the use of coordinate measuring machines (CMM) and automatic three dimensional inspection stations capable of checking a sculptured surface in one continuous sweep. *Wall thickness* on many cored turbine blade castings is determined ultrasonically. Nodularity is checked metallographically from the first and the last tree or cluster poured from heats of ductile iron. *Metallography* is an essential part of process development for high performance castings.

## 12. Design Advantages of Investment Castings

Designing for investment castings primarily aims to make full use of the enormous capability and flexibility inherent in the process to produce parts that are truly functional, cost effective and often more aesthetically pleasing. The principal advantages are described below.

- a. *Casting Complexity.* Almost any degree of external complexity as well as internal complexity (which is limited only by the state of the art in ceramic core manufacturing), can be achieved. As a result, numerous parts previously manufactured by assembling many separate, individual components are currently being made as integral castings, at much lower costs and often with improved functionality.
- b. *Wide Alloy Selection.* Any castable alloy can be used, including ones that are impossible to forge, or are too difficult to machine.

- c. *Close Dimensional Tolerances.* The absence of parting lines and the elimination of substantial amounts of machining by producing parts very close to final size give investment casting an enormous advantage over sand casting and conventional forging.
- d. *Prototype Tooling.* The availability of temporary and prototype tooling is a major advantage in the design and evaluation of parts. Quick and low expense tooling methods such as SLS, SLA available in rapid prototype production, described earlier, facilitate timely collaboration between designer and the foundry to produce parts that are functional and manufacturable. This capability is not found in such competitive processes as die casting, powder metallurgy or forging.
- e. *Reliability.* The long-standing use of investment castings in the aircraft engines for the most demanding applications has fully demonstrated their ability to be manufactured to the highest standards.
- f. *Wide Range of Applications.* In addition to complex parts and parts that meet the most severe requirements, investment casting also produces numerous simple parts competitively, due to the low tooling costs involved. Investment castings are competitively produced in sizes ranging from a few grams to more than 300 kg (660 lb).

### 13. Design Recommendations

The following recommendations provide a guide to the design of investment castings [16]:

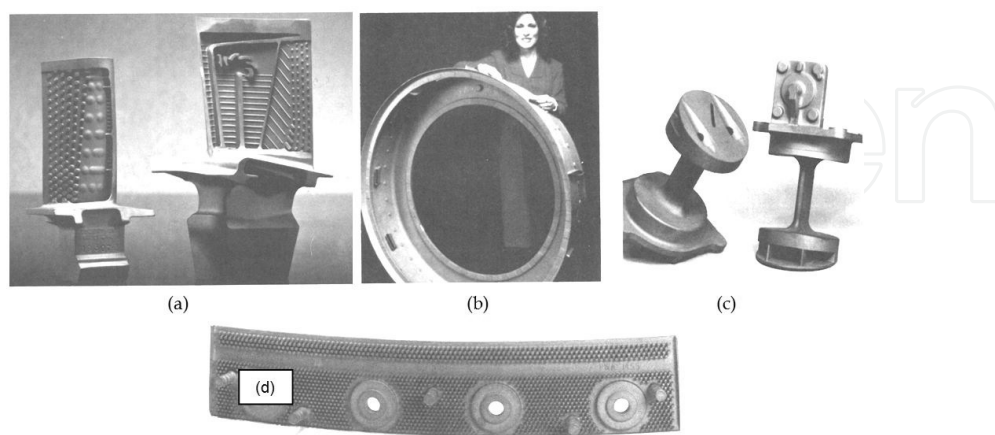
- Focus on final component cost rather than cost of the casting.
- Design parts to eliminate unnecessary hot spots through changes in section sizes, use of uniform sections, location of intersections, and judicious use of fillets, radii, and ribs.
- Use prototype castings to resolve questions of functionality, producibility, and cost.
- Do not overspecify; permit broader than usual tolerances wherever possible.
- Indicate datum planes and tooling points on drawings; follow ANSI Y 14.5M for dimensioning and tolerancing.

### 14. Applications

Applications for investment castings exist in numerous manufacturing industries. A partial list is given in Table 2. The largest applications are in the aircraft and aerospace industries, especially turbine blades and vanes cast in cobalt- and nickel-base superalloys, as well as structural components cast in superalloys, titanium, and 17-4 PH stainless steel. Examples of applications with castings in ceramic shells using wax patterns, ceramic and soluble cores, are shown in Fig. 5 to Fig. 7.

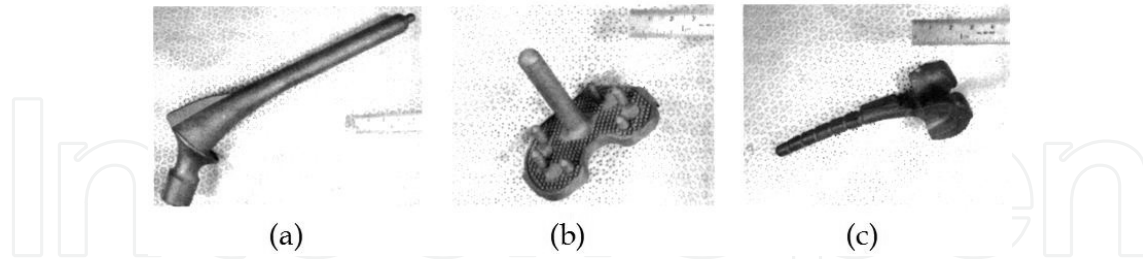
Aircraft engines, air frames, fuel systems	Machine tools
Aerospace, missiles, ground support systems	Materials handling equipment
Agricultural equipment	Metalworking equipment
Automotive	Oil well drilling and auxiliary equipment
Bailing and strapping equipment	Optical equipment
Bicycles and motorcycles	Packaging equipment
Cameras	Pneumatic and hydraulic systems
Computers and data processing	Prosthetic appliances
Communications	Pumps
Construction equipment	Sports gear and recreational equipment
Dentistry and dental tools	Stationary turbines
Electrical equipment	Textile equipment
Electronics, radar	Transportation, diesel engines
Guns and small armaments	Valves
Hand tools	Wire processing equipment
Jewelry	

**Table 2.** A partial list of applications of Investment Casting

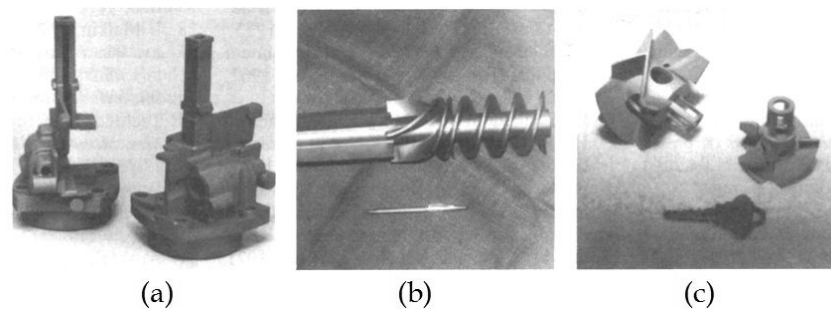


**Figure 5.** Aircraft and aerospace applications: (a) Single crystal turbine blades investment cast using complex ceramic cores. (b) 17-4 PH stainless steel fan exit case; weight: 96 kg (212 lb). (c) Aircraft fuel sensor strut cast in 17-4 PH stainless steel. (d) A curved metal component with circular features.

less steel, and (d) Aircraft combustion chamber floatwall, with numerous small posts on the wall. Courtesy of: Pratt Whitney Aircraft [7].



**Figure 6.** Biomedical applications for investment castings. (a) Hip-femoral prosthesis. (b) Knee-tibial base. (c) Elbow-humeral prosthesis. All cast in ASTM F75 cobalt-chromium-molybdenum alloy. [7].



**Figure 7.** Examples of other applications: (a) Nosepiece for nailgun cast in 8620 alloy steel. (b) Ni-resist Type II cast iron inducer for deep oil drilling. (c) Small 17-4 PH turbine vanes; small vane weighs 71 g (2.5 oz), larger vane 185 g (6.5 oz). [7].

## Appendix to: Progress in Investment Castings

### Guidelines for Designing Gating and Feeding Systems

#### 1. Introduction

In any casting process, when an alloy is poured into a mold, it starts to shrink or contract in volume as it cools down to liquidus temperature, and subsequently solidifies. Foundries compensate for these two stages of volumetric contractions by providing reservoirs – feeders - as parts of the mold cavity design. (The term “feeder” used here has the same meaning as “riser” used in sand- casting). The feeders freeze slower than the casting, thus allowing some of the liquid in the feeders to flow into the casting toward the areas where the shrinkage occurs.

Note: The third stage of volumetric alloy contraction or shrinkage, from solidus temperature to room temperature, generally called '*patternmaker's shrinkage*', is compensated for in the design of mold cavity and included in pattern tooling.

The feeding behavior of selected investment cast alloys was studied in a research carried out at University of Birmingham, UK, funded by Rolls Royce Limited, UK. [1-4]. The solution for a complete feeding system design includes the dimension, shape, location, method of attachment of feeders to the casting and the materials used. Similar approaches to what are used for sand casting can also be applied to investment casting, as was established in the above study.

However, unlike most sand casting applications, in investment casting, many gating and feeding elements perform dual or combined functions / roles: many elements adjacent to the cast component, initially assist or govern the mold filling operation, guide the molten metal as it flows in to the component cavity, and later during solidification, guide the flow of feeding liquid into this cavity to compensate for the first two stages of alloy contraction described earlier.

Additionally, as is the case with many small size investment castings, some of these gating-feeding elements are required to provide portions of feed liquid to many parts joined together to these elements, specifically for such a purpose.

In general, variations in the design of feeding systems for investment casting components arise because of differences in melting, molding and pouring methods used in foundries. Nevertheless, some general guidelines in procedure for feeding system design can be followed.

An approach is presented here for combining the feeder dimensioning concepts based on Chvorinov's rules, [9] with the experimental, theoretical and practical data available on feeding systems used for investment castings. This approach has been found effective in actual usage at many investment casting foundries, and with a wide range of cast alloys. To show how the procedure is used in practical applications, two examples of investment castings are included later in this appendix.

The feeding concepts for investment castings generated from this study have also been expanded to a PC-based computer program, *The AFS Investment Casting Feeding System*, distributed earlier by American Foundry Society [AFS].

## **2. Effect of Process Variables on Feeding:**

A summary of findings from the above study, primarily on the effects of process variables on feeding investment castings, (some of which show similarities, while some show marked differences with sand castings), are described here. The feeding concepts developed from these findings, as well as rules for dimensioning feeding elements and the procedure for feeding system design are described in subsequent sections: 3.0, 4.0 and 5.0.

## 2.1. Casting Geometry: Length, Width, Thickness, Taper, Cross-section Shape

### (a) Length

- i. Casting soundness improves, invariably, with reduced casting length, due to the increase in longitudinal temperature gradients.
- ii. Feeding range or feeding distance,  $f_d$ , of a single feeder was generally found to be  $(10 \times t)$ , where  $t$  is the casting section thickness, under normal casting conditions.
- iii. Feeding distance was found to increase by varying levels, with specific changes in process conditions, causing measured increases in longitudinal temperature gradients, such as with increased casting taper, freezing ratio, or with applied mold temperature gradients.

### (b) Width

Increasing casting width, up to a certain level, improves casting soundness, which was found to be due to the availability of wider channels for the feeding liquid.

### (c) Thickness

Thicker castings are easier to feed and have improved soundness owing to wider spacings between dendrites, both primary and secondary, which allow correspondingly wider feeding flow channels.

### (d) Taper

An increase in taper for both 'plate' (rectangular cross-section) and 'blade' (nearly trapezoidal cross-section) geometries used in this study, substantially improves casting soundness, due to improvement in longitudinal temperature gradients.

### (e) Cross-section Shape

'Plate' shapes with rectangular cross-section are easier to feed than 'blade' shapes, with identical overall length, width, and thickness, for similar conditions of casting, namely, casting and mold temperatures, feeding system and pressure head on the feeder. Wider feed flow channels available with 'plate' primarily cause this improvement.

## 2.2. Freezing Ratio, $k$

Freezing ratio,  $k$ , defined as the ratio of modulus of feeder to that of the casting ( $M_f / M_c$ ), is described more in section 4.0.

(a) Increasing the freezing ratio,  $k$ , in the range from 1.0 to 2.3, consistently improves casting soundness of 'plate' and 'blade' specimens. Increased longitudinal gradients, with increased primary and secondary dendrite arm spacings, cause wider feed flow channels, all of which promote strong directional and progressive solidification towards the feeder.

(b) The minimum value of freezing ratio,  $k$ , and volume ratio,  $V_f / V_c$  required to achieve radiographic soundness were obtained as follows:



Casting geometry	k	$V_f / V_c$
• 4 mm thick 'plates'	1.7	0.8
• 4 mm thick 'blades'	2.0	0.8
• 8 mm thick 'plates'	1.2	0.4
• 8 mm thick 'blades'	1.7	0.6
• Aerofoil blade	1.76	0.8

(c) The minimum limits of freezing ratio,  $k$ , and volume ratio,  $V_f / V_c$  can however be reduced appreciably by: the application of casting taper, or longitudinal gradients on the shell, or an increase in pouring temperature (from 1430 °C to 1500 °C for IN 100), or a suitable change in the gating design.

### 2.3. Mold Temperature and Applied Temperature Gradients

- i. Uniform mold temperature allows shallow temperature gradients to develop and persist, especially with increased casting length, causing increased shrinkage porosity.
- ii. Applying longitudinal temperature gradients to the mold substantially improves casting soundness.
- iii. To obtain improved mold filling and avoid casting misrun, it is advantageous to adjust (increase) mold temperature, while maintaining pour temperature, dependent on the casting geometry and the gating design.

### 2.4. Pouring Temperature

- i. Increase in pouring temperature (in the specified range of 1430 °C to 1500 °C for nickel base alloy IN 100) causes considerable improvement in casting soundness, for studied casting thicknesses.
- ii. However, as is widely acknowledged, lower pour temperature generally gives improved soundness in massive or thick casting sections, due to improved temperature gradients sustained during solidification; increased pour temperature creates shallow gradients in later stages of solidification in these thick sections, enhancing shrinkage pores.
- iii. On the other hand, with extended, thin sections, increased pour temperature, besides allowing easy mold fill (preventing any misrun), provides widened interdendritic channels, with adequate gradients for effective feeding.

### 2.5. Pressure: Metallostatic pressure, Atmospheric or Ambient Pressure

#### (a) Metallostatic Pressure

- i. An increase (of 60 mm) in metallostatic head,  $h$ , of 'plates' and 'blades' makes a substantial improvement in casting soundness, since it is a major propulsive force for feed liquid.
- ii. An increase of about 9% in metallostatic pressure (defined as  $P_h = \rho_L \times g \times h$ ) in nickel base alloy MAR M002, contributes partly to its improved feeding behavior compared to IN 100 (for the same casting conditions), because of the increased density in the liquid state,  $\rho_L$ .
- iii. The availability of metallostatic pressure prevailing at the feeding source can become restricted, or curtailed, due to premature lateral solidification, locally, at thinner sections in the running system of many bottom gated designs. This can result in macro-cavities or extensively interconnected micro-pores.
- iv. For casting under vacuum, metallostatic pressure is the main force propelling feed liquid to the growing solid-liquid interface both by macro-flow and by micro-flow.

#### **(b) Atmospheric or Ambient Pressure**

- i. The application of atmospheric pressure on top of the pouring basin or cup creates a substantial increase in the pressure head acting on the feed liquid.
- ii. However, a continuous liquid column from the region where atmospheric or any ambient pressure is applied, to the main source of feed supply, namely the feeder, is essential for adequate and continuous feeding to occur.
- iii. In all applications of pressure, the moduli of the pouring and of the running system are required to be larger than that of the feeder to prevent any premature lateral solidification cutting off the transmission of the applied pressure to the feeding liquid.

#### *2.6. Dissolved Gas*

- i. Increased levels of dissolved gases (for e.g., dissolved oxygen and nitrogen in excess of 15 ppm in nickel base alloy IN 100 bar stock) are found to substantially augment shrinkage pores, resulting in macro-cavities in many thicker sections in the casting.
- ii. Pores in fully-fed\* casting sections (\*as determined from separate experiments) are uniquely created by dissolved gases, and can be clearly identified by metallography due to their rounded shape, or the spherical surfaces.
- iii. Pores caused by dissolved gas can be reduced partially or locally in some casting sections by making changes to the gating design; however, separate degassing techniques are required to fully eliminate gas pores from the casting.

#### *2.7. Gating and Feeding System*

- i. Top-gated and side-gated feeding systems show consistently improved feeding efficiency as compared to bottom gated designs.

- ii. Top- gated and side-gated feeding systems show increased levels of longitudinal temperature gradient which promotes directional freezing, and hence assist effective feeding.
- iii. Top- gated and side-gated feeding systems show continued availability of metallostatic pressure on the feeder during solidification in all sections of the casting, as against the possible cut-off mechanism due to premature lateral solidification, in the bottom- gated design, which interrupts feed flow by curtailing metallostatic pressure from the feeder.

### 2.8. Alloy : Alloy Constitution, Structural Parameters

The feeding characteristics of the following three groups of metals and alloys are classified and identified, based on their solidification behavior, namely:

- i. alloys freezing with marked 'skin' formation, normally short freezing range alloys;
- ii. alloys showing 'pasty' or 'mushy' zone during freezing, normally longer freezing range alloys\*;
- iii. grey cast irons, which show little shrinkage during solidification, since the formation of graphite flakes involves an expansion, and requires rigid molds to inhibit casting expansion.

\*NOTE: Some alloys, generally with the intermediate freezing range, show 'mushy-skin' type of solidification. These alloys are found sensitive to rate of freezing: an alloy showing mushy-skin freezing in a sand casting may behave like a skin forming alloy when chill cast.

*Freezing range* of an alloy is defined as the difference between liquidus and the solidus temperature.

#### **Alloy Constitution**

(a) Specimens cast in nickel base alloy MAR M002 have consistently improved soundness compared to identical specimens cast in IN 100. The wider freezing temperature range of MAR M002, as compared to that of IN 100, is observed to have negligible detrimental effect on the process of feeding in MAR M002.

(b) The improved feeding behavior of MAR M002 compared to IN 100 is attributed to the following six factors:

- i. Consistently larger induced temperature gradients in MAR M002 specimens, compared to identical specimens in IN 100.
- ii. A progressive decrease in the rate of solidification from specimen ends to feeder, enabling the ease in macro- and micro –flow of feed metal, similar to IN 100 specimens cast in identical conditions.
- iii. Higher  $\gamma$ - $\gamma'$  eutectic content, of the order of 10-20% in MAR M002, than that in identical specimens in IN 100 with 1.0- 4.0% eutectic, contribute to the feed supply at the later stages of solidification.

- iv. The chain-like morphology of eutectic in MAR M002 suggests a more favorable morphology of feed channels for both macro-flow and micro-flow, than the kidney shaped eutectic observed in IN 100. This is consistently substantiated by the similarity in morphology of micropores, and  $\gamma$ - $\gamma'$  eutectic grains in MAR M002, as well as in IN 100 alloy. In addition, the micropores are observed to occur frequently adjacent to the eutectic nodules in both the alloys.
- v. Variations in the thermal properties of the two alloys, mainly specific heat and thermal conductivity in the liquid and the constituent solid phases, may also alter the morphology of feed channels during solidification and hence feeding characteristics of these alloys, and
- vi. An increase of about 9% in metallostatic pressure in MAR M002, for the same metallostatic head as available with IN 100 specimens, because of the increase in density of MAR M002 liquid.

### Structural Parameters

#### (a) Matrix Morphology and Grain Size

- i. Chill grains observed at surfaces of IN 100 specimens, especially at a lower pour temperature, do not influence the feeding process, i.e., have neither beneficial nor detrimental effect on feeding.
- ii. The morphology of columnar  $\gamma$  – grains in both IN 100 and MAR M002, clearly indicate the relative levels of heat abstraction from solidifying micro-regions through different parts of the section, the possible directions of growth and identifies the 'hot spot' region, especially in a complex geometry such as a 'blade' section, the thermal center for the section and hence freezes last. An examination of microstructure thus leads to an explanation for the morphology and distribution of shrinkage pores, resulting from inadequate feeding.
- iii. Measured width of columnar grains is directly related to primary dendrite arm spacing. While a wider grain leaves wider feed passages for micro-flow, a steep linear increase in arm spacing from specimen end to the feeder, which is inherent with steep longitudinal gradients, allows optimum size of channels for macro-flow.

#### (b) Dendrite Arm Spacing

- i. Measured values of secondary dendrite arm spacing can be directly related to rate and time of local solidification in sections at various distances from feeder, to indicate the progress of solidification as well as the morphology of feed channels available to feeding as affected by variations in casting parameters.
- ii. For the various casting parameters studied, including specimens with out taper (with constant section thickness), cast at uniform mold temperature ( zero applied gradient), and at the lower pour temperature, the dendrite arm spacing increases from specimen end to the feeder. However, any variation from linearity in this increase leads to simultaneous lateral solidification over longer regions of the casting,

and cut-off mechanisms operating on macro- and micro-flow, resulting in shrinkage porosity.

- iii. Application of taper on casting section thickness gives a steeper decrease in dendrite arm spacing with distance from feeder. An increase in thickness, or pouring temperature, or freezing ratio, or the application of gradients on the shell results, consistently, in wider arm spacing towards the feeder, and hence provide wider feed channels.

### 3. Feeding Concept for Investment Castings

Primarily based on the above findings on effect of process variables on feeding, the following components of the general concept have been developed on the feeding process in investment castings.

#### 3.1. Feeding Conditions

Conditions, as specified by rules on 'thermal and volumetric criteria' ( described in section 4.0 ) for dimensioning the feeders, followed by appropriate spacing of feeders to meet the 'feeding range demand' in complex castings, are sufficient to ensure radiographic soundness in skin freezing alloys [ 1]. However, in mushy-skin and mushy freezing alloys, the following additional conditions are required to be met in the design of feeding systems, particularly to obtain HDR, High Definition Radiography-soundness, Fig.11, in investment casting of long and thin components similar to airfoil blades:

- a. a strongly directional and progressive freezing from the end/s of the casting towards the feeder/s. This directional progress of solidification is governed mainly by three factors, namely: (i) thermal gradients in both longitudinal and transverse directions, (ii) the local rate of lateral solidification, and (iii) the local time of lateral solidification;
- b. an adequate pressure head on the liquid in the main source of liquid-feed supply, namely the feeder/s, to sustain propulsion of feed liquid to the growing solid-liquid interface/s.

#### 3.2. Feeding High Temperature Alloys and Other Investment Cast Alloys

(a) The metallographic examination of specimens, cast under different process parameters, lead to the conclusion that two of the alloys studied, IN 100 and MAR M002 can be classed with 'mushy-skin' freezing, and identified with intermediate freezing range alloys.

(b) From the observed morphology of the matrix and interdendritic spaces or feeding channels in these two alloys, the mechanisms operative in feeding can be grouped into: 'macro-feeding' and 'micro-feeding'. Macro-feeding through longitudinal channels is the main source of supply for lateral micro-flow, which feeds the solid-liquid interface through interdendritic channels. The feeder is the main source of supply for macro-feeding, which in turn, terminates in micro-feeding.

(c) While, in mushy freezing alloys, liquid feeding and mass feeding mechanisms operate during macro-feeding, in skin freezing alloys, liquid feeding is the main source for macro-flow. Interdendritic feeding is the mechanism operating in micro-flow [1-2].



(d) The driving force propelling both the macro-flow and the micro-flow is the pressure on the liquid in the feeder, mainly metallostatic and ambient pressure, and the negative contraction pressures developed with the growth of the solid-liquid interface.

(e) The major resistance to the flow of feed liquid, by both macro-flow and micro-flow is the viscosity of the liquid which increases as solidification progresses locally, the flow channels get narrowed, the liquid temperature drops and intermediate phases are precipitated in the liquid.

(f) Continuity in the supply of feed liquid by macro-flow can be cut-off by premature lateral solidification upstream, mainly due to shallow longitudinal gradients. Macro-flow mechanism through spaces between dendrite branches can be interrupted by growth cut off in flow direction caused by shallow longitudinal and transverse temperature gradients.

### *3.3. Temperature Gradients*

(a) Shallow longitudinal and transverse gradients lead to non-directional freezing, while steep gradients in the requisite directions, result in directional solidification. The flow distances required both in macro-flow and micro-flow get shortened in direct proportion to the increase in these gradients.

(b) Primarily poor thermal conductivity and high level of solidification temperatures, allow such alloys as steels, nickel base and cobalt base alloys generally to have steep temperature gradients. In addition, large chilling capacity of zircon normally used in the ceramic shell for these alloys, also contributes appreciably to the magnitude of the gradients. However, sustaining beneficial gradients through solidification for effective feeding requires controlling and monitoring other process factors identified in this study.

#### *3.3.1. Longitudinal Gradients*

(a) Longitudinal gradients are composed of three distinct components in the long plates and blades samples studied, namely: at the casting ends, at mid-sections, and near the feeder. While, the mid-component of the gradient is found to be shallow with non-directional freezing, it is made steep by strongly directional solidification.

(b) Application of longitudinal gradient on the shell mold, or a taper in the casting thickness, contributes selectively to one gradient component in the casting, mainly to increase the magnitude of the mid-section component.

(c) The following seven factors have been found to contribute, in varying levels, to some, or all three components, described above, in the longitudinal temperature gradient: (i) the casting 'end effect', (ii) loss of melt temperature as liquid metal fills in the mold, (iii) convection in the bulk liquid, (iv) casting geometry, (v) feeder contribution, (vi) variations in the chilling capacity of the mold, and (vii) gating method / design.



### 3.3.2. Transverse Gradients

As determined in the above investigation, transverse temperature gradients are mainly dependent on the following factors: (i) the difference between pouring temperature and the mold temperature, (ii) the thermal conductivity of the melt, and (iii) the mold chilling capacity [1-2].

### 3.4. Rate and Time of Solidification

(a) Spacings between dendrite arms,  $d$ , both primary stems and secondary branches are related to the rate and time of local solidification, and hence, indicate the progress of lateral solidification with distance (from feeder) and time (from start of freezing). Measured ' $d$ '-values illustrate the advance or growth of solid-liquid interface and the consequent morphology of feed channels available for macro-flow and micro-flow.

(b) Wide spacings between primary and secondary dendrites promote an appreciable improvement in the efficiency of both macro-feeding and micro-feeding.

(c) For optimum conditions of feeding, dendrite arm spacing increases linearly from casting / specimen end to the feeder, with as wide spacing as compatible, with the local cooling rate, which is mainly dependent on: casting and shell mold geometry, casting and mold temperatures, and heat transfer properties of alloy melt and mold.

### 3.5. Feeding Mechanisms in High Temperature Alloys and Other Cast Alloys

(a) Liquid feeding mechanism is the main source of supply for macro-flow which, in turn, feeds numerous micro-flow paths. A steep thermal gradient, both in longitudinal and transverse directions, is mainly responsible for the continuity in the supply of liquid feed.

(b) Observations of cast structure of IN 100 and MAR M002 suggest that primary  $\gamma$ - constituent does not participate in the mass flow mechanism of feeding. However, residual liquid streams may carry primary carbides or other intermediate phases formed near the liquidus temperature, early in the solidification. This could be to the detriment of end-feeding in the micro casting regions where the carried primary constituents may block or interrupt liquid flow into interdendritic spaces.

(c) Interdendritic feeding occurs by micro-flow in spaces between primary and sequential dendrite arms to compensate the shrinkage due to the growth of dendrites and interdendritic regions, continuously within the mushy zone, under optimum conditions of thermal gradient and freezing rate.

(d) A solid skin on castings forms at early stages of solidification, restricting the mechanism of solid feeding in all the casting geometries studied, namely: 'plates' (rectangular cross-section), 'blades' (nearly trapezoidal cross-section) and airfoils.

#### 4. Dimensioning Feeding Elements

The optimum size of a feeder is obviously that which will ensure the required soundness of the casting, with an adequate safety factor. For skin-freezing alloys the minimum feeder size to eliminate macroshrinkage is also adequate for satisfactory feeding. Larger feeder sizes do no harm apart from the possible danger of the feeder pipe extending into the casting, and being uneconomical.

Mushy freezing alloys, on the other hand, are more sensitive to the temperature gradients produced by the feeder. Feeder volume below the optimum size results in macropores as well as in distributed microporosity. Larger feeder heads are self-defeating since they delay freezing, diminish the temperature gradients and increase the amount of interdendritic porosity near the feeder.

##### 4.1. Modulus Method

Based on the original concepts by Chvorinov and subsequently elaborated by Wlodawer [9-10], rules have been formulated to determine the adequate feeder size for castings, Fig.8 to Fig.11.

*Modulus* is defined as the ratio of the volume to the cooling surface area of the casting (or a part of the casting) or the feeder.

$$M = V / CS \quad (1)$$

Where, V is the volume of casting, or feeder, and CS is the cooling surface area.

Modulus, also alternatively termed 'cooling modulus', or 'freezing modulus', relates amount of heat stored in casting or feeder (the volume component) to the rate of heat dissipation (via the cooling surface area). Many experimental observations have found the average solidification time in castings of numerous alloys, to be proportional to the square of the modulus.

In the modulus method, two rules have been postulated to calculate the adequate feeder size:

(a)The first rule ensures that the feeder is 'thermally adequate', that it freezes adequately later than all the casting sections being fed:

$$M_f = k \times M_c \quad (2)$$

where, k is identified as the freezing ratio, and  $M_f$  and  $M_c$  are moduli of feeder and casting respectively. The freezing ratio 'k' is initially set at a minimum of 1.2, for both short and long freezing range alloys.

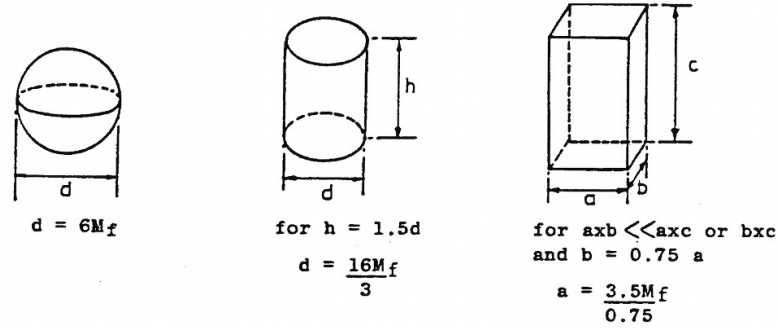


Figure 8. Feeder dimensions calculated from modulus value.

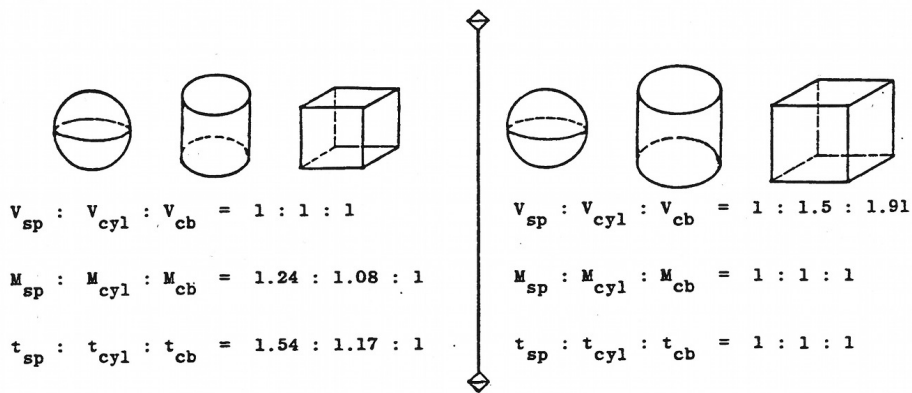


Figure 9. a) Comparing moduli and solidification times of a sphere, cylinder and cube of the same volume; (b) comparing volume of these shapes for the same solidification time.



Figure 10. Examples of casting designs requiring separate feeding of sections with different moduli, or to meet feeding distance requirements.

(b) The second rule ensures that the feeder is 'volumetrically adequate', that feeder has adequate volume of feed liquid to supply to casting sections being fed:

$$V_f = V_c \times \left\{ \frac{\beta}{(\eta - \beta)} \right\} \tag{3}$$

where,  $V_f$  and  $V_c$  are the volumes of feeder and the casting sections being fed,  $\beta$  is alloy solidification shrinkage, and  $\eta$  is the available feeding liquid factor, relating to the feeder efficiency and is empirically determined.

Note: (i)  $\beta$  is composed of the first two stages of alloy contraction, namely,  $\beta = \beta_L + \beta_F$ , where  $\beta_L$ , the liquid contraction volume, is of the order of 1% of the total liquid volume, per 180 °F (100 °C), and  $\beta_F$  is the alloy freezing contraction, varies from 0 to 6.5%, and (ii)  $\eta$  is found empirically to be about 18% under normal casting conditions; and can be substantially increased (thereby, correspondingly reducing required feeder size) with specific changes in process conditions made to enhance local temperature gradients, such as with casting taper, applied mold gradients, or selective mold ceramic insulation.

#### 4.2. Number of Feeders and Positioning of Feeders

(a) Feeders are placed in direct contact with the heavier sections of the casting, as this enables directional solidification to be maintained through out freezing. While castings of simple shapes can be fed by a single feeder, in many castings with varying section thicknesses, the concept of feeder/s location divides itself into natural zones of feeding, each feeder centered on a heavy section, separated from the others by a thinner section, Fig.8 to Fig.10.

Each zone is fed by a separate feeder and hence the number of such zones determines the number of feeders required.

(b) In the case of rangy castings (mainly with long, thin sections), the 'feeding range' or 'feeding distance' of the feeder, rather than the constriction (or thin sections between thick ones), is the factor limiting the operation of each feeder. This is due to the fact that appreciable and sustained temperature gradients are required to feed extended thin sections.

(c) To achieve maximum metallostatic pressure, feeders should be positioned as high as possible relative to the casting. This is particularly important in mushy freezing alloys, since metallostatic head is often the only effective source of feed pressure; owing to the absence of an intact skin, the casting sections as well as the feeder remain accessible to atmospheric pressure. In skin forming alloys, atmospheric pressure is an important factor in feeding.

#### 4.3. Attachment of Feeders to Castings

(a) Partly because of the economic importance of reducing costs in removal of feeders from castings and partly to control temperature gradients, feeders are connected to castings by 'feeder necks' with reduced cross sections.

(b) For satisfactory completion of feeding, the neck should solidify after the casting, but before the final solidification of the feeder. Should neck freeze prematurely, the casting will contain shrinkage, no matter how large the feeder itself is.

(c) The necessary minimum neck dimensions vary with the casting design and method, but as a first approximation the neck requires a cross sectional area equal to, or greater than, the section it is designed to feed.

(d) Based on the modulus concept, modulus of feeder neck,  $M_n$ , is determined from:

$$M_n = k_n \times M_c \quad (4)$$

where  $k_n$  is the freezing ratio of feeder neck. It is recommended that initially  $k_n$  is set at 1.1, and the neck shape and dimensions are such that the moduli of casting, neck and the feeder are in the ratio ( 1: 1.1: 1.2 ).

### 5. Procedure for Feeding System Design for Investment Castings

As mentioned earlier, a complete feeding system design involves, to varying levels, each of the different stages of the investment casting process. A step- by- step procedure is described here, and includes designing the optimum feeder system based on the modulus method, after modifying all other process factors towards a common goal of superior casting quality.

{References and links in these instructions are made to the serial number attached to each step, such as: 1, 2....16, 17}

#### Casting Design

Step 1. *Design Modifications*: Examine casting geometry to verify if freezing of casting sections provides directional cooling gradients towards the feeder(s). If needed, obtain customer's agreement on design modifications to improve temperature gradients for directional solidification, for attaching feeders and for quality control purposes.

Step 2. *Alloy Selection*: Alloy is normally selected by the designer from standard specifications and alloy handbooks. To meet process requirements, consultation between the designer and the foundryman is necessary. If several alloys are feasible, carry out a value analysis.

Step 3. *Feeding System*: Using the modulus method, identify from the casting design the number and location of feeders. Select an appropriate gating and feeding system from a standard grid (or cluster, or tree), modified grid, or a specially designed feeder system. Generally such a cluster or grid consists of a framework of vertical and horizontal members attached to a pouring basin (or cup) and patterns. Detailed adjustment to feeder(s) location is made later.

Step 4. *Cutoff & Cleaning*: Check on the suitability of proposed feeding system for available ways of cutting off the feeders.

#### Alloy Properties

Step 5. *Feeding Properties*: In consultation with designer, make necessary adjustments to the alloy composition (small additions of / or dilution in alloying elements) of the selected alloy to improve feeding characteristics, such as freezing range, eutectic volume and casting fluidity.

Step 6. *Melt Treatments*: Feeding behavior of many alloys can also be enhanced by influencing the freezing nucleation and growth behavior, by various melt controls. Check on the specified testing procedures for alloy melt quality controls: composition, grain size, microstructure, residual gases, inclusions, superheat times and temperatures, pouring temperatures, and for obtaining test bars for mechanical property tests.



Step 7. *Product Quality*: Final casting quality is influenced by mold phenomena such as mold atmosphere, flow of metal, cooling directions and rates due to mold materials. The production of porosity-free castings depends on the success of the whole feeding system. Check on the specified product quality control tests (types of procedures for nondestructive or destructive tests in relation to the casting design, the alloy used and product applications).

### **Mold Construction**

Step 8. *Patternmaking and Assembly*: Examine the effects of gating and feeding system on making pattern dies and pattern assembly. Explore alternative methods of clustering patterns on the tree, or grid, (location and orientation) or in the mold to produce favorable feeding temperature gradients during mold preheating and alloy pouring, while ensuring adequate cluster rigidity. Remember, although each casting is freezing on its own, the whole grid acts as a single cooling system.

Step 9. *Gating*: Select the gating system to optimize flow for favorable feeding temperature gradients, which minimize flow turbulence and maximize feeding pressure. Explore the feasibility of horizontal, vertical and bottom gating. Review the feeding requirements in relation to pattern assembly while optimizing gating system functions. Design the gating and feeding systems by considering jointly both the flow and feeding requirements. For grid systems, identify parts of the grid that act at the same time as feeding and gating elements.

Step 10. *Mold Materials*: Examine whether standard mold, feeder wall materials, mold making and preheating techniques should be altered (insulation, chilling) to improve feeding temperature gradients.

Step 11. *Feeding Pressure*: The total feeding pressure acting on the feeding liquid flow is important in the last stages of freezing when flow channels become narrow and fine. Obtain the fullest possible benefit of atmospheric and metallostatic pressures on the feeding liquid, and reduce, separately, dissolved gases and inclusions in the alloy to a minimum.

### **Dimensioning Feeding Elements**

Step 12. *Number of Feeders*: Establish from casting design, step (2) and steps (3), (6), (8), (9), (10), and (11), whether directional feeding of the whole casting could be obtained from one single feeder. Calculate freezing moduli ( $V/CS$ ) of section(s) that have to be fed separately. Exclude the calculation of all "parasite" sections (thinner casting sections-such as bosses, fed by thicker adjacent sections) attached to the feeding parts. Exclude noncooling surfaces (casting surface not facing the mold) in modulus calculation. For complex sections, apply the shape substitution principle.

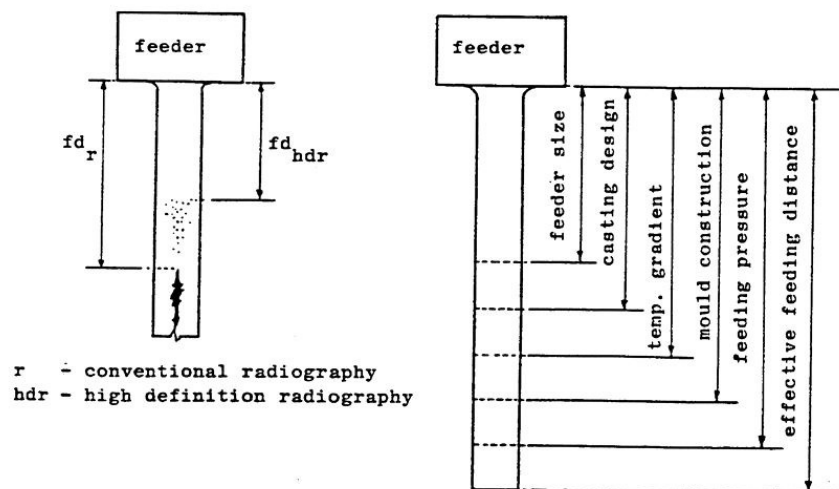
Step 13. *Feeder(s) Shape and Locations*: Select feeder shape and location from steps (2), (4), (8), (9), (10), (11) and (12). For grid systems, verify that the elements of the gating system that take part in the feeding flow also obey the freezing modulus rules, in step (14).

Step 14. *Feeder Volume from Freezing Time*: Calculate the feeder volume from:  $M_f = k \times M_c$ , where the freezing moduli of casting,  $M_c$  are obtained from step (12), while the value of 'k' is selected from steps (1), (8), (10), and (11), and feeder shape from step (13).

Step 15. *Feeder Volume from Volumetric Criterion*: Compare feeder volume obtained from step (14) with that derived from:  $V_f = V_c \times (\beta / \eta - \beta)$ . where  $V_c$  is the total volume of all parts, including parasite sections, which are fed from a single feeder,  $\beta$  is total (liquid and freezing) contraction percent and  $\eta$  is the available feeding liquid factor, e.g., feeding volume delivery percent of a feeder arising under conditions noted in steps (8) and (13).

Step 16. *Feeder Neck*: Calculate the feeder neck dimensions from:  $M_n = k_n \times M_c$ , where  $k_n$  value and neck shape are selected from steps (1), (3), (4), (6), (8) and (9). Note:  $k_n$  can initially be set at 1.1.

Step 17. *Feeding Distance*: Finally, calculate the feeding distance,  $f_d$  of each feeder from the equation,  $f_d = 10 \times t$ . Verify from steps (3), (8), (10), (11) and (12) that required temperature gradients would be obtained to meet the necessary feeding distance to completely feed all casting sections, Fig. 11.



**Figure 11.** Feeding distance sensitivity to various alloy, mold and feeding system parameters studied.

The design of feeding system based on the above procedure for two practical investment casting samples are described below:

### Example 1

The engineering drawing, Fig 12, gives essential dimensions and other requirements for the selected casting "Clamping Arm".

Gunmetal, the customer specified alloy has the composition: Cu 88%, Sn 8%, Zn 4%. Alloy shrinkage,  $\beta$ , is estimated at 6%. At a volume feed delivery,  $\eta$  of 18%, its volume ratio derived from equation-3,  $VR = (V_f / V_c) = 0.50$  (or 50%). This criterion sets the minima for feeder sizes required to ensure volumetric adequacy in the supply of feed liquid.

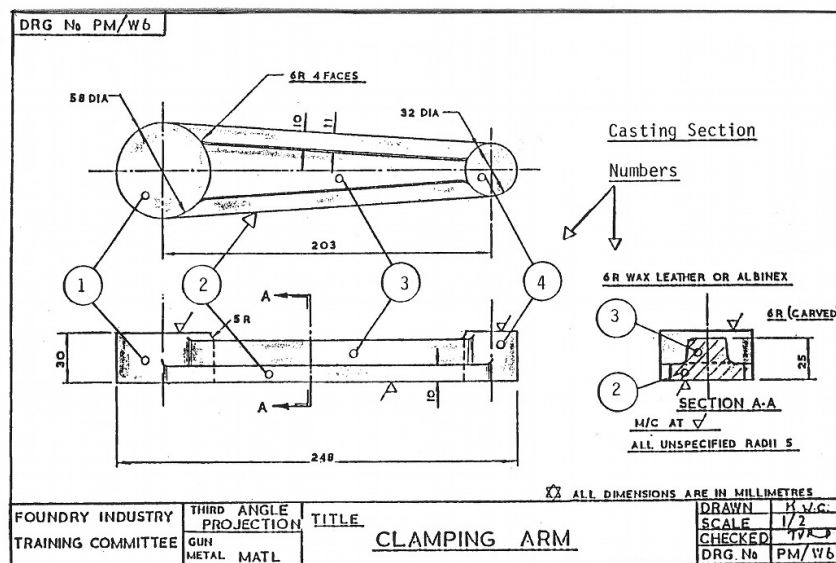
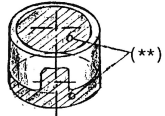
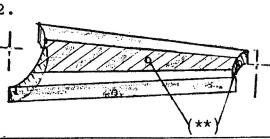
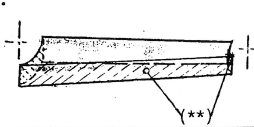
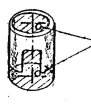


Figure 12. Engineering drawing of 'Clamping Arm' casting with casting section numbers for modulus calculation.

Casting Section	V (mm <sup>3</sup> )	CS (mm <sup>2</sup> )	M = V/CS (mm)	Remarks
1. 	79,262.4	6,717.2	11.8	<ul style="list-style-type: none"> <li>o Slowest to freeze.</li> <li>o Requires a separate and adjacent feeder.</li> </ul>
2. 	74,118.4	13,984.6	5.3	<ul style="list-style-type: none"> <li>o First portion to freeze.</li> </ul>
3. 	66,360.0	9,216.7	7.2	<ul style="list-style-type: none"> <li>o Second portion to freeze.</li> </ul>
4. 	24,127.4	3,093.3	7.8	<ul style="list-style-type: none"> <li>o Freezes later than arms #2 and #3.</li> <li>o Requires a separate and adjacent feeder.</li> </ul>

Total volume = 243,868.2 (\*\*Hatched portions are non-cooling surfaces.)

Figure 13. shows modulus calculations for the Clamping Arm.

The casting is divided into four sections, and modulus for each calculated, Fig. 13. From their modulus values, it is seen that the arm (#2) and rib (#3) solidify ahead of the smaller cylinder (#4). The big cylinder (#1) is the last section to freeze. This shows that a feeder #1 is required to feed the big cylinder (#1), which in turn can feed the arm (#2) and the rib (#3).

However a separate feeder #2 is required to feed the small cylinder (#4), since thinner sections cut off feed supply to it from feeder #1.

Feeder Details	$\sum V_{C(i)}$ * (mm <sup>3</sup> )	$\hat{M}$ ** (mm)	$M_f = k \times \hat{M}$ (mm)	Feeder Size
<p>• Feeder #1</p> <p>Feeder neck</p> <p>Feeder neck</p> <p>• Feeder #2</p>	$V_{C1} + V_{C2} + V_{C3} =$ 219,740.8	11.8	14.2 (k=1.2)	<ul style="list-style-type: none"> <li>• Side of square feeder #1 <math>d = 4 \times M_f = 57.0\text{mm}</math></li> <li>• At 70mm length, <math>V_f = 227,430\text{mm}^3</math></li> <li>• It is volumetrically capable of feeding two castings on either side, with <math>VR = 0.52</math></li> </ul> <p>o Feeder Neck Minimum size = <math>4 \times 1.1 \times \hat{M} = 52.0\text{mm dia.}</math></p> <p>This neck leaves 3mm. wide annulus called 'Witness,' which provides reference surface for snagging and other finishing operations after cut-off.</p>
	$V_{C4} =$ 24,127.4	7.8	9.4 (k=1.2)	<ul style="list-style-type: none"> <li>• Side of square feeder #2 = <math>4 \times M_f = 38.0\text{mm}</math></li> <li>• At 38mm length, <math>V_f = 54,872\text{mm}^3</math></li> <li>• On feeding #4 on either side <math>VR = 1.14</math></li> </ul> <p>• Feeder Neck Size = <math>4 \times 1.1 \times 7.8 = 34.3\text{mm}</math></p>

Note: \*Total volume of Sections fed; for e.g. volume of sections #1, #2, #3 for feeder #1.  
 \*\*Highest modulus  $\hat{M}$  amongst fed casting sections; for e.g.  $\hat{M} = M_1$  for feeder #1.

Figure 14. Feeder Dimensions for the Clamping Arm.

In order to take advantage of the substantial taper in the arm (#2) and the rib (#3), this component can be cast in a vertical orientation, Fig. 14. In this orientation, gravity provides necessary feed pressure to feeder #1 (and the cylinder #1) to feed the long arm (#2) and the rib (#3).

Feeder #1 is designed to feed three sections, namely, the big cylinder (#1), the arm (#2) and the rib (#3).

Feeder #1 modulus  $M_f = k \times M_c$ , from equation -2. With freezing ratio, k, at 1.2, and  $M_c$  the highest modulus among fed sections as that of section #1,  $M_f = 14.2$

Modulus of a square bar feeder of side d,  $M_f = d/4$ , when feeder is considered part of a grid and two side surfaces are noncooling, Fig 14. Hence, the side of feeder #1,  $d = 4 \times M_f = 57.0$  mm.

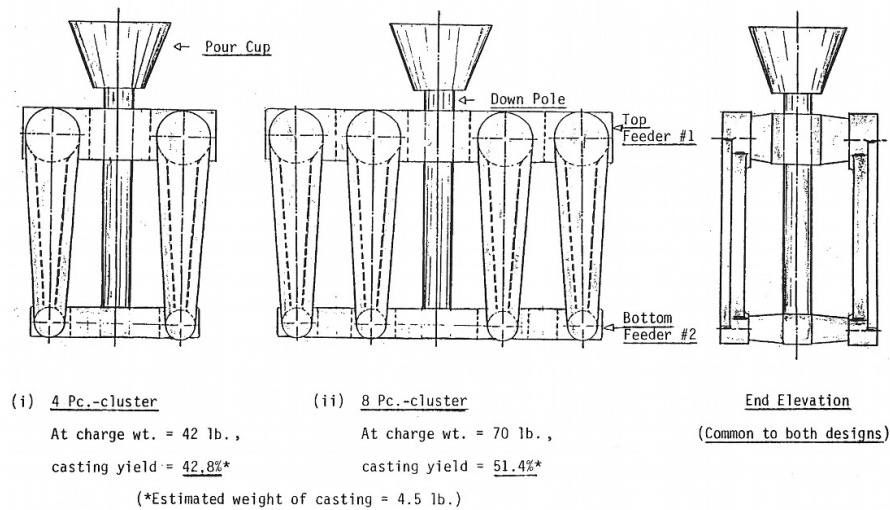
At 70 mm length\*,  $V_f = 227,430$  mm<sup>3</sup>. This feeder #1 has a volume ratio,  $VR = V_f / V_c = 1.04$ , if attached to one casting. It is hence advantageous to attach a second casting on the other side of the same feeder.

This results in,  $VR = 0.52$ , which is  $> 0.50$ , and hence satisfies the volumetric criterion.

\*NOTE: The length of the two feeders # 1 and # 2 in this grid, effective in feeding is assumed to be ~ 120% of the larger dimension, e.g., diameter of attached casting section ( # 1 and # 4, respectively ).

Feeder neck sizes are calculated from equation-4:  $M_n = k_n \times M_c$

Minimum neck size (frustrum of cone) =  $(4 \times 1.1 \times 11.8) = 52$  mm diameter. This allows a 3 mm wide annulus on the casting surface called 'witness', which provides a reference surface for finish operations. The length of the feeder neck, shown as 15 mm, is to allow for easy fettling or cutoff.



**Figure 15.** Alternative designs of feeding systems.

Minimal size for the second *feeder #2* is determined in a similar way:  $M_f = k \times M_c$ , where  $M_c$  is the modulus of cylinder #4. Side,  $d$ , of a square bar feeder is found to be 38 mm.

To check if *feeder #2* has sufficient volume at a length of 38 mm \* (see note above),  $V_f$  is found to be 54,872 mm<sup>3</sup> and volume ratio  $VR = 1.14$ , on feeding cylinder #4 on either side. Thus, it easily satisfies the volume criterion of  $VR \geq 0.50$ .

Feeder neck size for this feeder is found similarly. Minimum neck size is found to be:  $(4 \times 1.1 \times 7.8) = 34.3$  mm.

To verify the feeding distance,  $f_d$ , of the feeders:  $f_d = 10 \times t = 250$  mm, using the combined thickness ( $t = 25$  mm) of arm and rib (section AA in the drawing Fig. 12). This shows that *feeder #1* can feed the cylinder #1 effectively, as well as the complete length of arm (#2) and the rib (#3). The second *feeder #2* can feed the adjacent section #4 effectively.

Two alternative designs for feeding grids are given in examples in Fig. 15, namely: a 4-piece cluster that can be cast successfully with an alloy charge weight of 42 lb (19 kg); this gives a casting yield of 42.8%; 8- piece cluster with an alloy charge weight of 70 lb (32 kg) giving a casting yield of 51.4%.

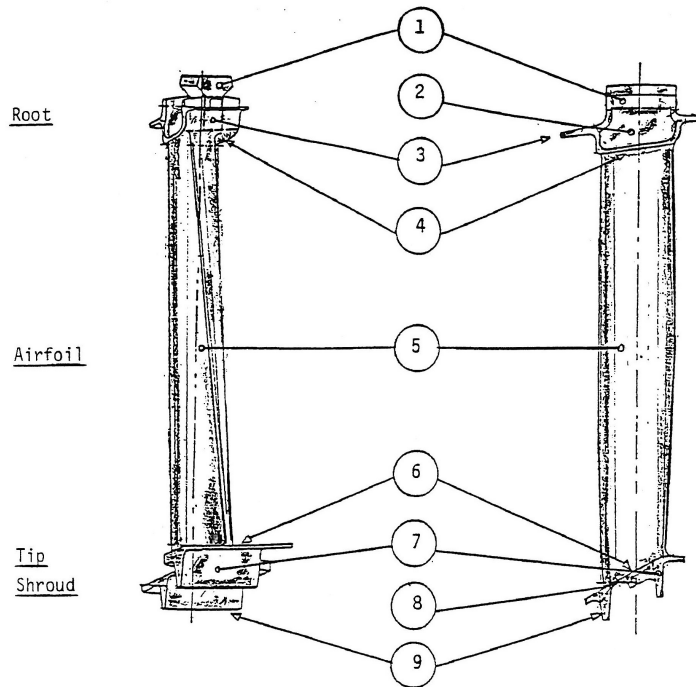
Other alternative designs, such as 6-piece clusters, are possible, and are again fitted with optimal sizes of feeders. An optimum feeding grid can be selected based on available foundry facilities, such as in shell- making or melting. For instance, the 8-piece cluster mold would



require robotic dipping for making the shell, while manual dipping is adequate in making the 4-piece cluster.

### Example 2

The engineering drawing in Fig. 16 shows casting section numbers (S/N) for a typical aero-engine turbine rotor blade.



**Figure 16.** Depicting casting section numbers for turbine blade.

Nickel-base alloy IN-713C selected by the customer for this blade has been found to have good castability. Alloy shrinkage,  $\beta$ , is estimated at 6%, and volume feed delivery,  $\eta$  of 18% to give a minimum volume ratio,  $VR = V_f / V_c = 0.50$  (or 50%), as derived from equation-3.

Calculated modulus values for various sections of the blade are shown in Fig. 17. Figure 18 shows two examples of calculating modulus for complex and irregular shapes.

To calculate the modulus for airfoil section #5, the end profiles (usually supplied by the customer at magnifications of 10X or 20X) are imprinted on suitable graph paper. Area for each of these profiles is obtained by counting the squares ( $A_n$ ) and adjusting the magnification ( $A_n \div 10^2$  or  $20^2$ ). The perimeter for each profile is obtained by measuring the curved lines ( $P_m$ ) with a bow compass (set at constant 10 mm in this case) and adjusting for the magnification ( $P_m \div 10$  or  $20$ ).

Modulus for the airfoil section #5 is given by the following equation- 5.

$$V = L_{AV} \times \frac{A_T + A_B}{2}, CS = L_{AV} \times \frac{P_T + P_B}{2}, M = V / CS \quad (5)$$

where,  $L_{av}$  is the average length of airfoil; ( $A_T, A_B$ ) and ( $P_T, P_B$ ) are area and perimeter at sections TT and BB, Fig. 18 (a)

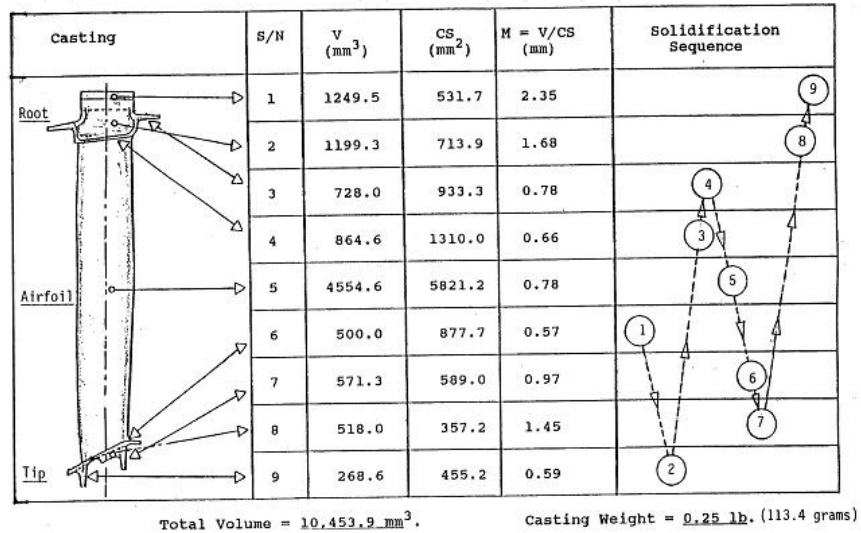


Figure 17. Calculated modulus values for turbine rotor blade.

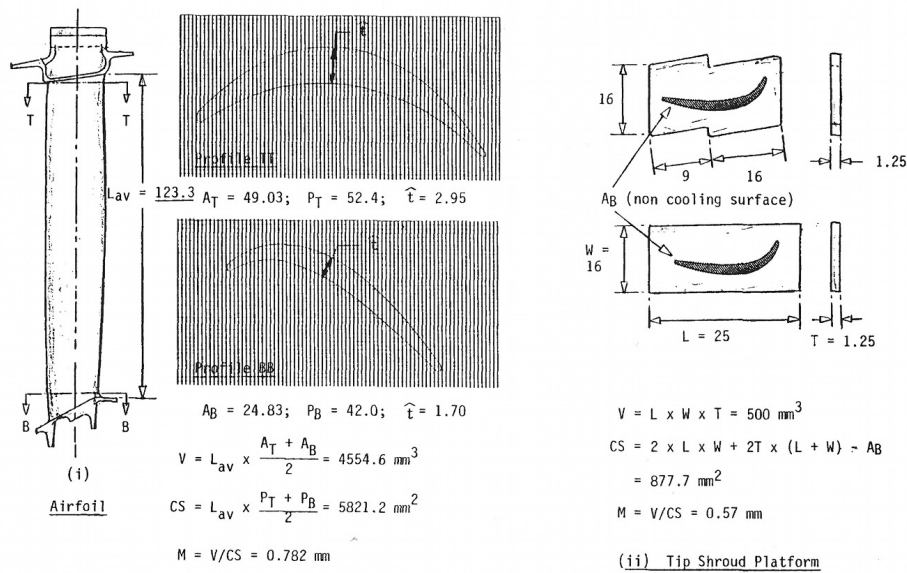


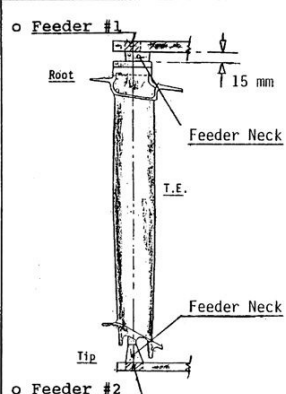
Figure 18. Modulus calculations using: (a) magnified airfoil profile, (b) the 'substitution principle'.

Note: Using a digitizer assists greatly in these measurements. Additional airfoil profiles at intermediate locations can be measured to improve on the accuracy or to analyze long air-

foils with large variations in the profiles. However, with current advancements in CAD and a variety of computer simulation software, the above computed modulus values are readily displayed for analysis and design of feeders by the foundry.

An irregular shape, like the Z-shaped shroud platform, is substituted by a rectangular plate as shown in Fig. 18 (b). Here, area  $A_b$  of the airfoil profile, where the top joins this shroud, is a noncooling surface and, hence, is deducted from the total surface area of the rectangular plate. Individual expertise in usage of this technique is attained easily by working out the differences between actual shape and the substituted shape for the first few castings.

The sequence of solidification can be inferred from modulus for the sections, Fig.17. Solidification is observed to commence at the parasite sections #6, 9, 4 and 3. The airfoil section #5 freezes next, followed by the tip sections #7 and 8 and root sections #2 and 1. This progress of solidification clearly calls for two feeders #1 and 2, with feeder # 1 feeding root sections and the airfoil, while feeder #2 feeds the tip sections.

Feeder Details	$\sum V_C(i)^*$ (mm <sup>3</sup> )	$\hat{M}^{**}$ (mm)	$M_f = k \times \hat{M}$ (mm)	Feeder Size
	$\sum_{i=1}^5 V_C(i)$ = 8596.0	$M_1 = 2.35$	2.82 (k=1.2)	<ul style="list-style-type: none"> <li>Side of square feeder #1 <math>d = 4 \times M_f = 11.5\text{mm}</math></li> <li>But, to be volumetrically adequate at <math>L_f = 25\text{mm}</math>, <math>d = 13.1\text{mm}</math></li> <li>Feeder Neck: a rectangular wedge-shaped bar from the feeder, with min. size = <math>4 \times 1.1 \times M = 9.4\text{mm}</math></li> </ul>
	$\sum_{i=6}^9 V_C(i)$ = 1857.9	$M_8 = 1.45$	1.74 (k=1.2)	<ul style="list-style-type: none"> <li>Side of square feeder #2 <math>d = 4 \times M_f = 7.0\text{mm}</math></li> <li>But, to meet volumetric contraction, <math>d = 7.9\text{mm}</math></li> <li>Feeder Neck: a rectangular wedge from the square bar feeder, with min. size = <math>4 \times 1.1 \times M = 6.4\text{mm}</math></li> </ul>

Note: \*Total volume of Sections fed; for e.g.  $\sum$  volume of sections #1, #2, #3, #4, #5 for feeder #1.  
 \*\*Highest modulus  $\hat{M}$  amongst fed casting sections; for e.g.  $\hat{M} = M_8$  for feeder #2.

Figure 19. Feeder Dimensions for: turbine rotor blade.

Calculations for feeder dimensions are shown in Fig.19. Modulus,  $M_f$  for feeder#1 =  $k \times M_1 = 2.82$ ; modulus of root section #1,  $M_1$  being the highest. Side of a square bar feeder,  $d=4 \times M_f = 11.5 \text{ mm}$ .;  $V_f = 3306.3 \text{ mm}^3$  at a feeder length of 25 mm. But  $VR = V_f / V_c = 3306.3/ 8596$ .  $VR = 0.38$  is below the allowed minimum volume ratio. To adequately feed the volumetric contraction of these sections, required  $V_f = 0.5 \times 8596 = L_f \times d^2$  ; Feeder length,  $L_f = 25 \text{ mm}$ .

Required side,  $d$ , of square bar feeder is given by:  $d= \sqrt{171.9} = 13.1 \text{ mm}$ .

For this feeder, the minimum feeder neck size =  $1.1 \times 4 \times M_1 = 9.4 \text{ mm}$ . To ensure ease in cut off operation, a neck height of 15 mm is provided.

Feeder #2 is designed to feed tip sections # 6, 7, 8 and 9 with the highest modulus  $M_8 = 1.45$ .

$M_f = 1.2 \times 1.45 = 1.74$ . Side of bar feeder =  $4 \times M_f = 7.0$ ;  $V_f = 735 \text{ mm}^3$  at  $L_f = 15 \text{ mm}$ . But this gives  $VR = 0.39$ . To be sufficient volumetrically,  $V_f = 929 = 15 \times d^2$ . Required side,  $d$ , of square bar feeder #2, is given by:  $d = \sqrt{61.9} = 7.9 \text{ mm}$ .

Minimum feeder neck size for this feeder =  $4 \times 1.1 \times M_g = 6.4 \text{ mm}$ . This can be a rectangular wedge, tapering from the square feeder #2 toward rail section # 8, Fig. 19.

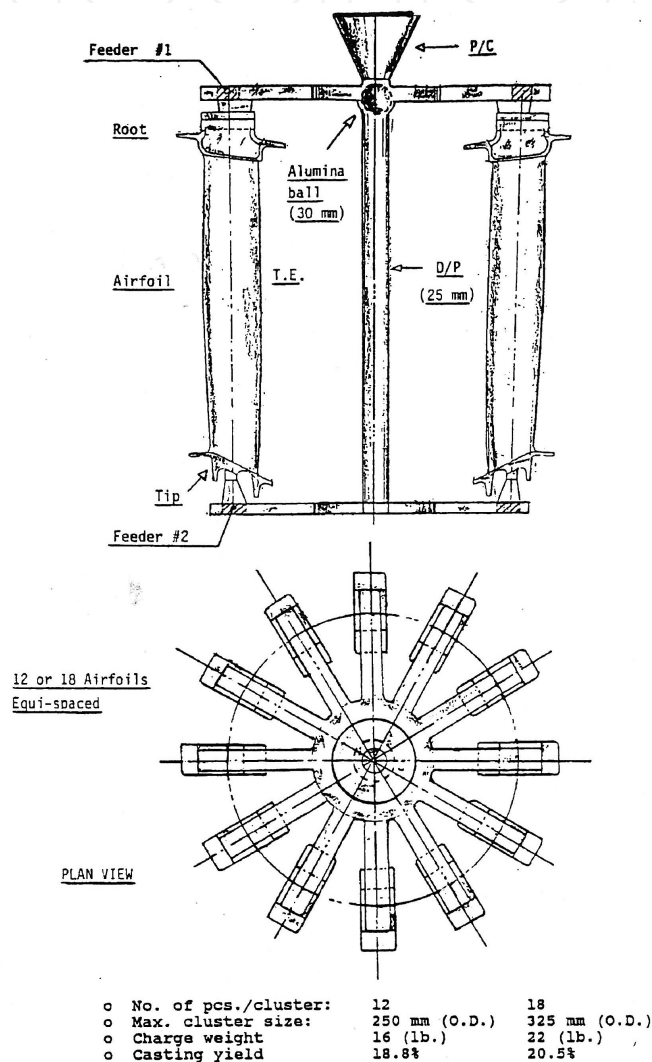
To check out the efficacy of these feeders, especially over the length of the airfoils, the feeding distance for each feeder is computed as follows: for feeder # 1,  $f_d = 10 \times t = 10 \times 2.95 = 29.5 \text{ mm}$ ; and for feeder #2,  $f_d = 10 \times t = 10 \times 1.70 = 17.0 \text{ mm}$ .

The combined feeding distance is only 46.5 (= 29.5+17.0) mm. But this analysis ignores the sharp taper of  $0.62^\circ$  in the airfoil from tip to the root (2.95 mm steeply tapering to 1.70 mm over the airfoil length of 123.3 mm), which allows for certain "auto feeding" along the length of the airfoil.

However, this casting-taper-directed help towards feeding can be obstructed if convergence of liquid metal flow through bottom and top runners occurs at mid-airfoil. When this happens, adverse temperature gradients develop in the bottom half of the airfoil, which work against feeding due to the sharp taper. To prevent this and to effectively feed the length of the airfoil, it is necessary to create beneficial gradients by techniques such as the following:

- i. An alumina / ceramic ball (~ 30 mm diameter) properly seated on a downpole, D/P (~ 25 mm diameter) is used to deflect the pour stream; the liquid metal is allowed to flow through the "top star" runners only, Fig. 20. This uni-directional fill induces temperature gradients that support the self-feeding actions of the casting taper. This "ceramic-ball-valve" technique is dependent on the location and size of the ball, D/P, and the ball seating for functioning efficiently/ effectively. This ball placed on a spherical or tapered seating stays locked in place (submerged) when the melt stream hits it. It blocks the flow through D/P completely and allows flow only laterally through the top runners. When all the component cavities are filled up, the flow surges up through the D/P, "popping-up" the ball into the pour cup (P/C), Fig. 20. Evidence that the ball has performed as expected is obtained when the ball is seen lodged on top of the P/C after pouring / casting.
- ii. Selective use of insulating ceramic kaowool wraps around the mold (wrapped prior to preheating and maintained during casting) has been found effective in feeding long airfoil sections, with reduced number of intermediate feeders to airfoil mid-sections. Normally, this selective- wrapping involves having about  $\frac{1}{2}$ " thick kaowool fully around the mold (leaving Pour cup top open) including the mid-airfoil sections, and placing gradually increased layers of kaowool, (each layer with  $\sim \frac{3}{8}$ " to  $\frac{1}{2}$ " additional blanket) towards the top as well as the bottom feeders, to promote the required gradients towards the top as well as the bottom feeders. The required temperature gradients are developed both during the preheating of mold as well as selective heat dissipation during solidification. This technique, however, may require iterative trials to obtain the required level of soundness in airfoil castings.
- iii. A combination of the above two techniques can be adopted to promote beneficial gradients in long airfoil sections. Other innovative techniques to create required mold

temperature gradients have been effectively developed [4-6] for long, thin airfoil investment castings, required to be cast sound, specifically with out intermediate feeders (to attain the required higher, specific mechanical properties in these castings). The mold gradients in such cases have been created and maintained, using graphite susceptor in Interlock furnaces with multi-coil induction heating capabilities (conventionally used for the production of D.S. and single crystal investment castings) and with the selective use of selected mold materials, with varying chilling capacities.



**Figure 20.** A comparison of alternative feeding systems.

A comparison of two alternative designs of gating-cum-feeding systems is shown in Fig. 20; both are circular clusters, each fitted with optimal feeder sizes: (i) a 12-piece cluster, 250 mm O.D., with a casting yield of 18.8%, and (ii) an 18-piece cluster, 325 mm O.D. with a casting yield of 20.5%. Where foundry facilities permit, it is advantageous to use the larger size cluster with a higher casting yield.



## Acknowledgements

Late Professor Voya Kondic, University of Birmingham, UK, for his inspiring guidance during author's research on feeding investment castings, research supported by Rolls-Royce Limited, UK.

R.A. Horton, with thanks for permitting use of figures and tables from his article on 'investment casting', ASM Handbook, Volume15, 2008

## Author details

Ram Prasad\*

Address all correspondence to: rprasad@aerometals.com

Aero Metals Inc., USA

## References

- [1] Prasad, Rama T. V. (1980). University of Birmingham, UK, \* Note: the author Ram Prasad's name before US Citizenship on September 16, 2011
- [2] Prasad, Rama T. V., & Kondic, V. (1994). Basic elements of Feeding Investment Castings. *American Foundry Society*.
- [3] Prasad, Rama T. V., & Kondic, V. (1994). Designing Feeding Systems for Investment Castings AFS Modern Casting, September
- [4] Prasad, Rama T. V. (1989). Method of Casting a Metal Article. , U.S. Patent 4,809,764,
- [5] Prasad, Rama T. V. (1990). Method of Casting a Metal Article,. *U.S. Patent*, 4,905,752,.
- [6] Prasad, Rama T. V. (1991). Method and Apparatus for Casting a Metal Article,. *U.S. Patent*, 5,072,771,.
- [7] Horton, R. A. (2008). Investment Casting. Casting, ASM Handbook,, 15
- [8] Brooks, R. (2012). Still Rapid, but Much More than Prototyping. *Foundry Management & Technology* March, 16.
- [9] Chvorinov, N. (1940). *Giesserei*,, 27, 177.
- [10] Wlodawer, R. (1966). Directional Solidification of Steel Castings,. Pergamon London,
- [11] Anonymous. (1979). *Ceramic Test Procedures*,, Investment Casting Institute.

- [12] Uram, S. (1978). Commercial Applications of Ceramic Cores, Paper presented at the 26th Annual Meeting, Oct 1978, Investment Casting Institute
- [13] Magnier, P. (1973). Titanium Investment Castings for Aircraft Applications. *May, British Investment Casters Technical Association.*
- [14] Jackson, J. D., & Fassler, M. H. (1985). *Developments in Investment Casting,,* Investment Casting Institute.
- [15] Mikkola, P., & Scholl, G. (2008). Low- Pressure Countergravity Casting. *Casting, ASM Handbook,,* 15
- [16] Bidwell, H. T. (1969). Design and Application of Investment Castings. *Investment Casting,,* Machinery Publishing,.

IntechOpen