

PUBLISHED BY

INTECH

open science | open minds

World's largest Science,
Technology & Medicine
Open Access book publisher



3,250+
OPEN ACCESS BOOKS



106,000+
INTERNATIONAL
AUTHORS AND EDITORS



111+ MILLION
DOWNLOADS



BOOKS
DELIVERED TO
151 COUNTRIES

AUTHORS AMONG

TOP 1%
MOST CITED SCIENTIST



12.2%
AUTHORS AND EDITORS
FROM TOP 500 UNIVERSITIES



Selection of our books indexed in the
Book Citation Index in Web of Science™
Core Collection (BKCI)

WEB OF SCIENCE™

Chapter from the book *Polyurethane*

Downloaded from: <http://www.intechopen.com/books/polyurethane>

Interested in publishing with InTechOpen?
Contact us at book.department@intechopen.com

Polyurethane: An Introduction

Eram Sharmin and Fahmina Zafar

Additional information is available at the end of the chapter

<http://dx.doi.org/10.5772/51663>

1. Introduction

1.1. History of polyurethane

The discovery of polyurethane [PU] dates back to the year 1937 by Otto Bayer and his coworkers at the laboratories of I.G. Farben in Leverkusen, Germany. The initial works focussed on PU products obtained from aliphatic diisocyanate and diamine forming polyurea, till the interesting properties of PU obtained from an aliphatic diisocyanate and glycol, were realized. Polyisocyanates became commercially available in the year 1952, soon after the commercial scale production of PU was witnessed (after World War II) from toluene diisocyanate (TDI) and polyester polyols. In the years that followed (1952-1954), different polyester-polyisocyanate systems were developed by Bayer.

Polyester polyols were gradually replaced by polyether polyols owing to their several advantages such as low cost, ease of handling, and improved hydrolytic stability over the former. Poly(tetramethylene ether) glycol (PTMG), was introduced by DuPont in 1956 by polymerizing tetrahydrofuran, as the first commercially available polyether polyol. Later, in 1957, BASF and Dow Chemical produced polyalkylene glycols. Based on PTMG and 4,4'-diphenylmethane diisocyanate (MDI), and ethylene diamine, a Spandex fibre called Lycra was produced by Dupont. With the decades, PU graduated from flexible PU foams (1960) to rigid PU foams (polyisocyanurate foams-1967) as several blowing agents, polyether polyols, and polymeric isocyanate such as poly methylene diphenyl diisocyanate (PMDI) became available. These PMDI based PU foams showed good thermal resistance and flame retardance.

In 1969, PU Reaction Injection Moulding [PU RIM] technology was introduced which further advanced into Reinforced Reaction Injection Moulding [RRIM] producing high performance PU material that in 1983 yielded the first plastic-body automobile in the United States. In 1990s, due to the rising awareness towards the hazards of using chloro-

alkanes as blowing agents (Montreal protocol, 1987), several other blowing agents outpoured in the market (e.g., carbon dioxide, pentane, 1,1,1,2-tetrafluoroethane, 1,1,1,3,3-pentafluoropropane). At the same time, two-pack PU, PU- polyurea spray coating technology came into foreplay, which bore significant advantages of being moisture insensitive with fast reactivity. Then blossomed the strategy of the utilization of vegetable oil based polyols for the development of PU. Today, the world of PU has come a long way from PU hybrids, PU composites, non-isocyanate PU, with versatile applications in several diverse fields. Interests in PU arose due to their simple synthesis and application protocol, simple (few) basic reactants and superior properties of the final product. The proceeding sections provide a brief description of raw materials required in PU synthesis as well as the general chemistry involved in the production of PU.

2. Raw materials

PU are formed by chemical reaction between a di/poly isocyanate and a diol or polyol, forming repeating urethane groups, generally, in presence of a chain extender, catalyst, and/or other additives. Often, ester, ether, urea and aromatic rings are also present along with urethane linkages in PU backbone.

2.1. Isocyanates

Isocyanates are essential components required for PU synthesis. These are di- or polyfunctional isocyanates containing two or more than two $-NCO$ groups per molecule. These can be aliphatic, cycloaliphatic, polycyclic or aromatic in nature such as TDI, MDI, xylene diisocyanate (XDI), meta-tetramethylxylylene diisocyanate (TMXDI), hydrogenated xylene diisocyanate (HXDI), naphthalene 1,5-diisocyanate (NDI), p-phenylene diisocyanate (PPDI), 3,3'-dimethyldiphenyl-4, 4'-diisocyanate (DDDI), 1,6 hexamethylene diisocyanate (HDI), 2,2,4-trimethylhexamethylene diisocyanate (TMDI), isophorone diisocyanate (IPDI), 4,4'-dicyclohexylmethane diisocyanate (H_{12} MDI), norbornane diisocyanate (NDI), 4,4'-dibenzyl diisocyanate (DBDI). Figure 1 shows examples of some common isocyanates.

The isocyanate group bears cumulated double bond sequence as $R-N=C=O$, wherein the reactivity of isocyanate is governed by the positive character of the carbon atom (Scheme 1), which is susceptible to attack by nucleophiles, and oxygen and nitrogen by electrophiles.

If R is an aromatic group, the negative charge gets delocalized into R (Scheme 2), thus, the aromatic isocyanates are more reactive than aliphatic or cycloaliphatic isocyanates. In case of aromatic isocyanates, the nature of the substituent also determines the reactivity, i.e., electron attracting substituents in ortho or para position increase the reactivity and electron donating substituents lower the reactivity of isocyanate group. In diisocyanates, the presence of the electron attracting second isocyanate increases the reactivity of the first

isocyanate; para substituted aromatic diisocyanates are more reactive than their ortho analogs primarily attributed to the steric hindrance conferred by the second $-NCO$ functionality. The reactivities of the two $-NCO$ groups in isocyanates also differ with respect to each other, based on the position of $-NCO$ groups. For example, the two $-NCO$ groups in IPDI differ in their reactivity due to the difference in the point of location of $-NCO$ groups. TMXDI serves as an aliphatic isocyanate since the two isocyanate groups are not in conjugation with the aromatic ring. Another isocyanate of increasing interests is vinyl terminated isocyanate since along with the $-NCO$ group, the extra vinyl group provides sites for crosslinking (Figure 2).

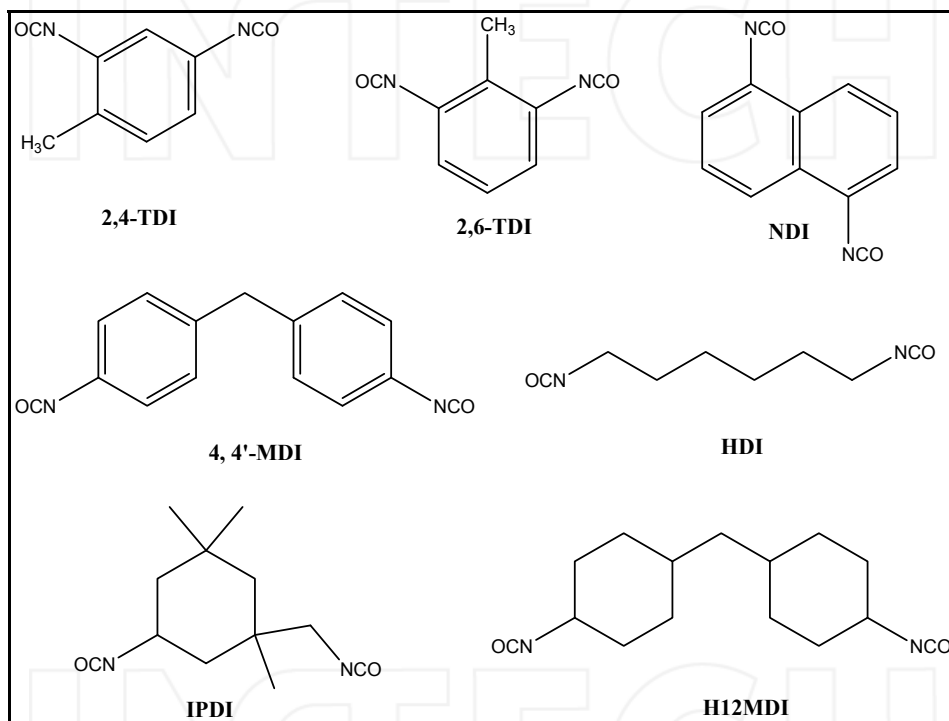
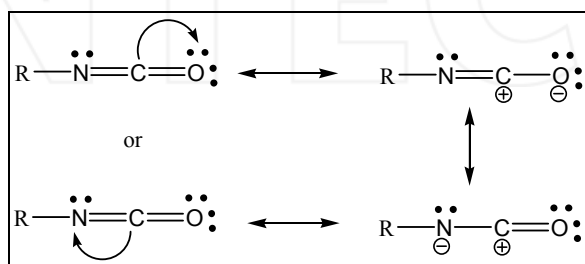
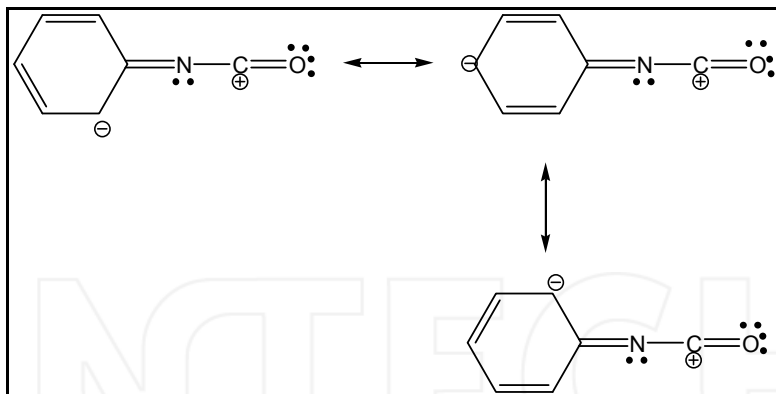

Figure 1. Common isocyanates



Scheme 1. Resonance in isocyanate



Scheme 2. Resonance in aromatic isocyanate

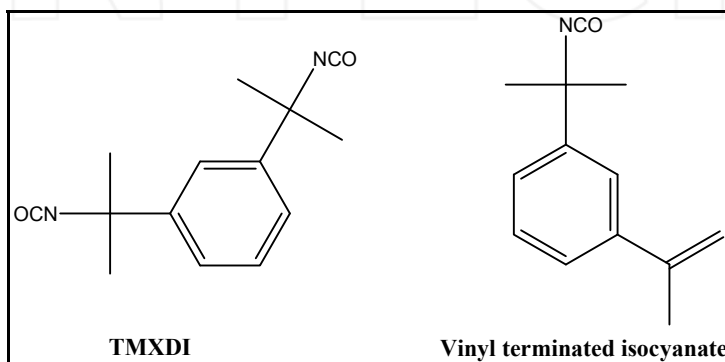

Figure 2. Other isocyanates

Polyisocyanates such as triisocyanates derived as TDI, HDI, IPDI adducts with trimethylolpropane (TMP), dimerized isocyanates termed as uretdiones, polymeric MDI, blocked isocyanates (where alcohols, phenols, oximes, lactams, hydroxylamines are blocking agents) are also used in PU production. Lately, fatty acid derived isocyanates are also prepared via Curtius rearrangement with view to produce entirely biobased PU. The choice of the isocyanate for PU production is governed by the properties required for end-use applications. To prepare rigid PU, aromatic isocyanates are chosen, however, PU derived from these isocyanates show lower oxidative and ultraviolet stabilities.

2.2. Polyols

Substances bearing plurality of hydroxyl groups are termed as spolyols. They may also contain ester, ether, amide, acrylic, metal, metalloid and other functionalities, along with hydroxyl groups. Polyester polyols (PEP) consist of ester and hydroxylic groups in one backbone. They are generally prepared by the condensation reaction between glycols, i.e., ethylene glycol, 1,4-butane diol, 1,6-hexane diol and a dicarboxylic acid/anhydride (aliphatic

or aromatic). The properties of PU also depend upon the degree of cross-linking as well as molecular weight of the starting PEP. While highly branched PEP result in rigid PU with good heat and chemical resistance, less branched PEP give PU with good flexibility (at low temperature) and low chemical resistance. Similarly, low molecular weight polyols produce rigid PU while high molecular weight long chain polyols yield flexible PU. An excellent example of naturally occurring PEP is Castor oil. Other vegetable oils (VO) by chemical transformations also result in PEP. PEP are susceptible to hydrolysis due to the presence of ester groups, and this also leads to the deterioration of their mechanical properties. This problem can be overcome by the addition of little amount of carbodiimides. Polyether polyols (PETP) are less expensive than PEP. They are produced by addition reaction of ethylene or propylene oxide with alcohol or amine starters or initiators in presence of an acid or base catalyst. PU developed from PETP show high moisture permeability and low T_g, which limits their extensive use in coatings and paints. Another example of polyols is acrylated polyol (ACP) made by free radical polymerization of hydroxyl ethyl acrylate/methacrylate with other acrylics. ACP produce PU with improved thermal stability and also impart typical characteristics of acrylics to resultant PU. These PU find applications as coating materials. Polyols are further modified with metal salts (e.g., metal acetates, carboxylates, chlorides) forming metal containing polyols or hybrid polyols (MHP). PU obtained from MHP show good thermal stability, gloss and anti-microbial behavior. Literature reports several examples of VO based PEP, PETP, ACP, MHP used as PU coating materials. Another example is VO derived fatty amide diols and polyols (described in detail in chapter 20 Seed oil based polyurethanes: an insight), which have served as excellent starting materials for the development of PU. These PU have shown good thermal stability and hydrolytic resistance due to the presence of amide group in the diol or polyol backbone.

2.3. Additives

Along with a polyol and an isocyanate, some additives may also be required during PU production, primarily to control the reaction, modify the reaction conditions, and also to finish or modify the final product. These include catalysts, chain extenders, crosslinkers, fillers, moisture scavengers, colourants and others. In PU production, catalysts are added to promote the reaction to occur at enhanced reaction rates, at lower temperatures, for deblocking the blocked isocyanates, for decreasing the deblocking and curing temperatures and times. A number of aliphatic and aromatic amines (e.g., diaminobicyclooctane-DABCO), organometallic compounds (e.g., dibutyltin dilaurate, dibutyltin diacetate), alkali metal salts of carboxylic acids and phenols (calcium, magnesium, strontium, barium, salts of hexanoic, octanoic, naphthenic, linolenic acid) are used as catalysts. In case of tertiary amines, their catalytic activity is determined by their structure as well as their basicity; catalytic activity increases with increased basicity and decreases with the steric hindrance on the nitrogen atom of amine. They promote their catalytic action by complex formation between amine and isocyanate, by donating the electrons on nitrogen atom of tertiary amine to the positively charged carbon atom of the isocyanate. Metal catalysts bear superiority

over tertiary amines because they are comparatively less volatile and less toxic. Metals catalyse the isocyanate-hydroxyl reaction by complex formation with both isocyanate and hydroxyl groups. The positive metal centre interacts with electron rich oxygen atom of both the isocyanate and hydroxyl groups forming an intermediate complex, which by further rearrangement results in the formation of urethane bonds. Difunctional low molecular weight diols (ethylene glycol, 1,4-butanediol, 1,6-hexanediol), cyclohexane dimethanol, diamines, hydroxyl-amines (diethanolamine and triethanolamine) are used as chain extenders in PU synthesis while those with functionality 3 or > 3 are used as crosslinkers. Since isocyanates are too sensitive to moisture or water even in traces, moisture scavengers, which react more readily with water than an isocyanate, are incorporated to cut off/eliminate the involvement of water during PU synthesis, e.g., oxazolidine derivatives, zeolite type molecular sieves. Blowing agents are used to produce PU foams with cellular structures by foaming process (e.g., hydrocarbons, CO₂, hydrazine).

3. Chemistry of PU

PU are carbonic acid derivatives. The older term for them is an ester of a substituted carbamic acid, polycarbamate, from carbamic acid. PU are formed by (i) the condensation polymerization reaction of bischloroformates with diamine (Scheme 3) and (ii) addition polymerization reaction of diisocyanates with di or polyfunctional hydroxy compounds, or other compounds having a plurality of active hydrogen atom (Scheme 4). The latter method is more important from the industrial point of view since in this method no by-product is formed.

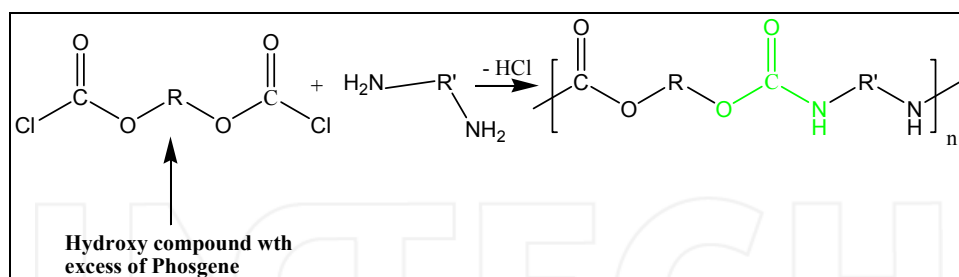

Scheme 3. Reaction of bischloroformate with diamine

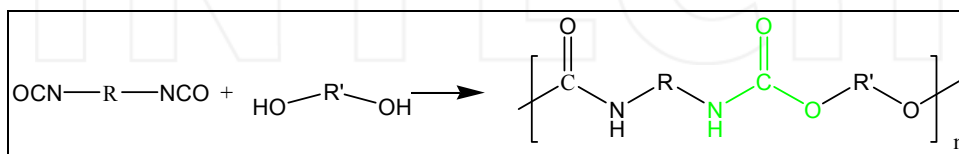

Scheme 4. Reaction of diisocyanate with di or poly hydroxy compound

The isocyanate reaction offers the possibility of producing tailor-made polymeric product ranging from fibres to rubber. Generally, the isocyanate reactions are divided into two

classes, (a) addition (primary and secondary) reaction with compound containing active hydrogen (Schemes 5 and 6), (b) self-addition reaction (Scheme 7). In some of the reactions, CO₂ is released which assists in the formation of PU foams.

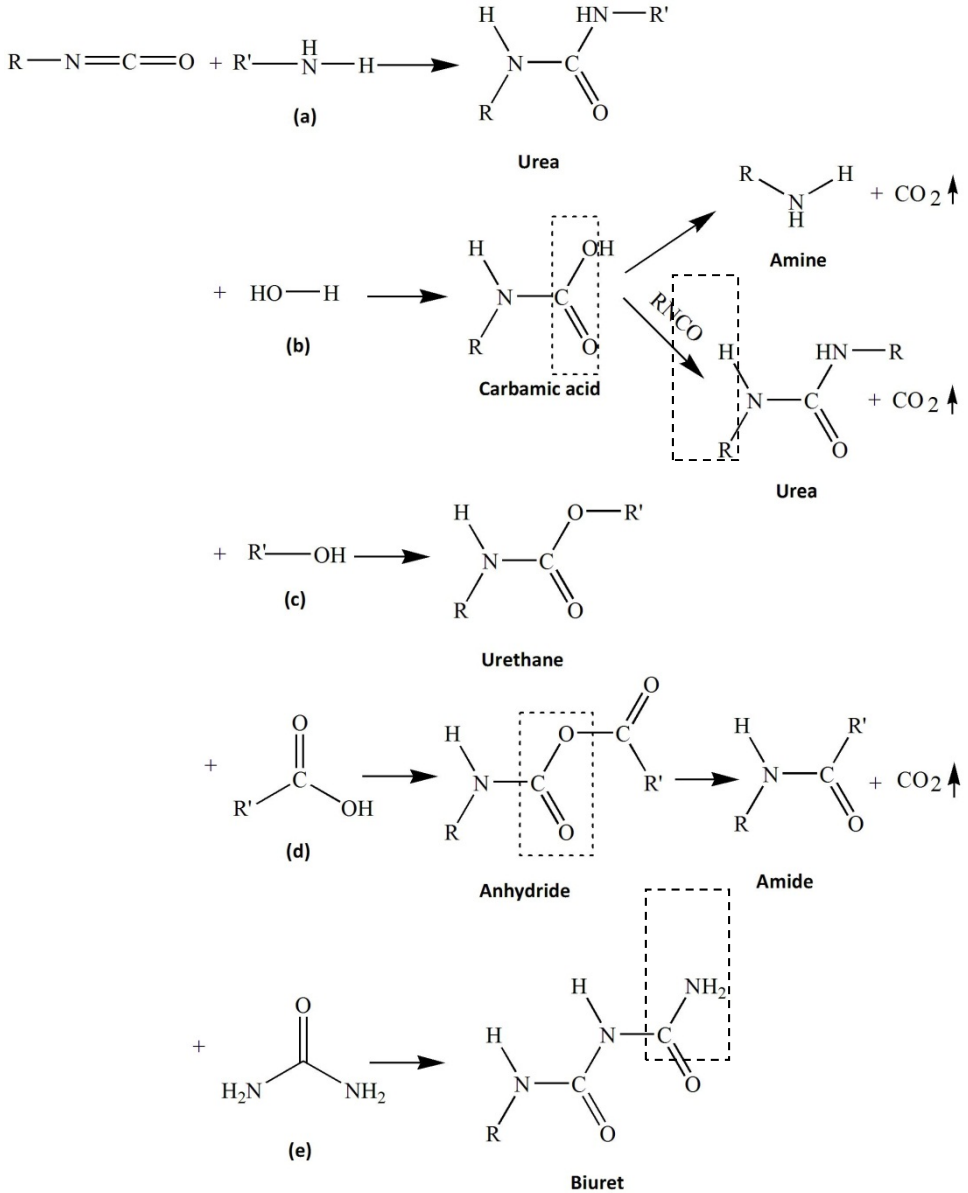

Scheme 5. Primary addition reactions of isocyanate with (a) amine, (b) water, (c) alcohol, (d) carboxylic acid, (e) urea.

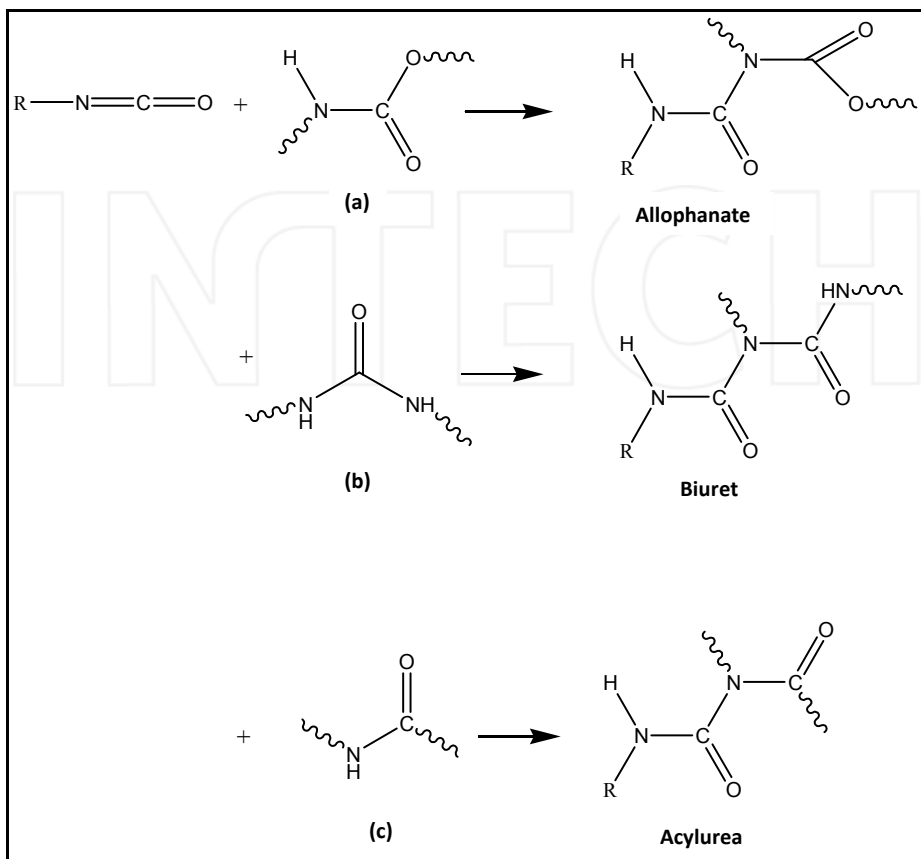

Scheme 6. Secondary addition reactions of isocyanate with (a) polyurethane, (b) polyurea and (c) polyamide

Wurts in 1848 discovered the basic reaction of isocyanate (Scheme 4). He found that isocyanates having the structure $R-N=C=O$, where R = alkyl or aryl group, react rapidly at room temperature with compounds containing active hydrogen atoms, like amine, water, alcohol, carboxylic acid, urethanes and ureas (Scheme 8).

It is observed that a linear PU is formed when a diisocyanate react with diol whilst branched or cross-linked PU results with the reaction of polyhydric compound (polyol). The branched or cross-linked PU are also formed when a compound containing three or more isocyanate groups reacts with a diol; however, this approach is of limited commercial importance.

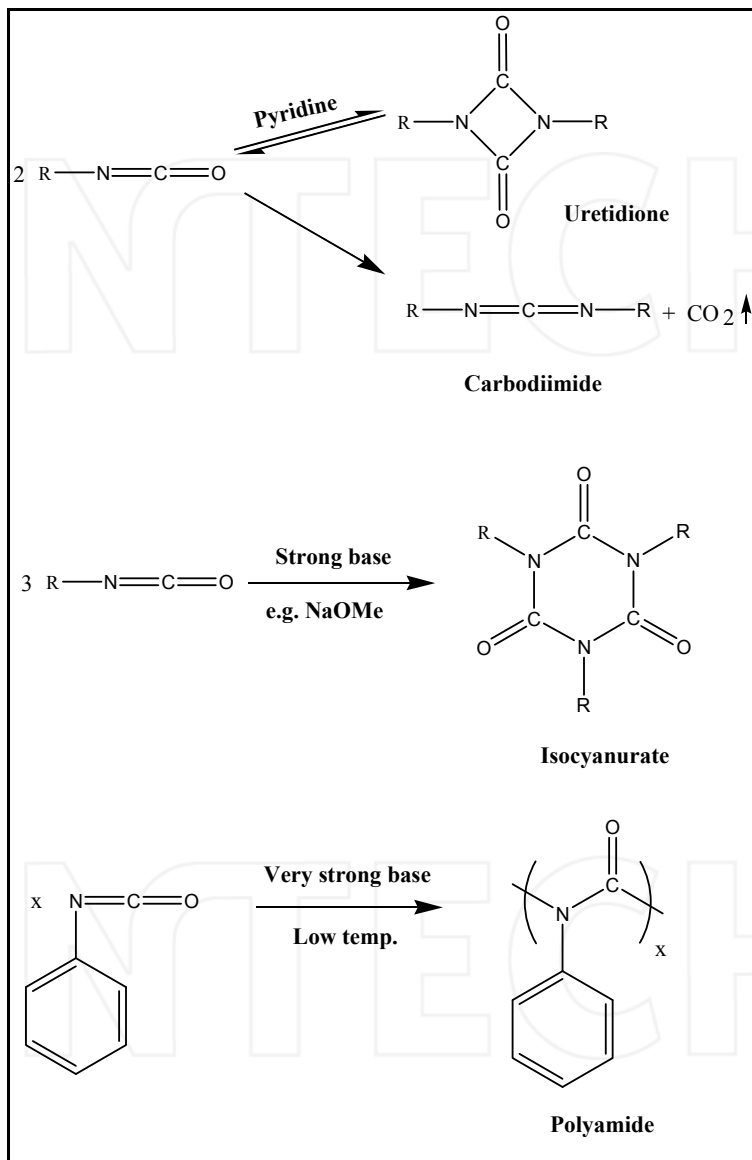

Scheme 7. Self-addition reactions of isocyanate

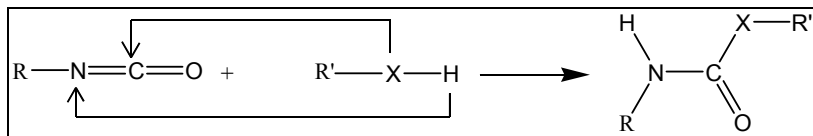

Scheme 8. Reaction of isocyanate with active hydrogen compound

4. Mechanism

The reaction of an isocyanate with active hydrogen compounds is carried out with or without a catalyst. The self-addition reactions of isocyanates do not usually proceed as readily as reactions with active hydrogen compounds.

4.1. Reaction in the absence of a catalyst

The active compound itself acts catalytically in the reaction as follows (Scheme 9).

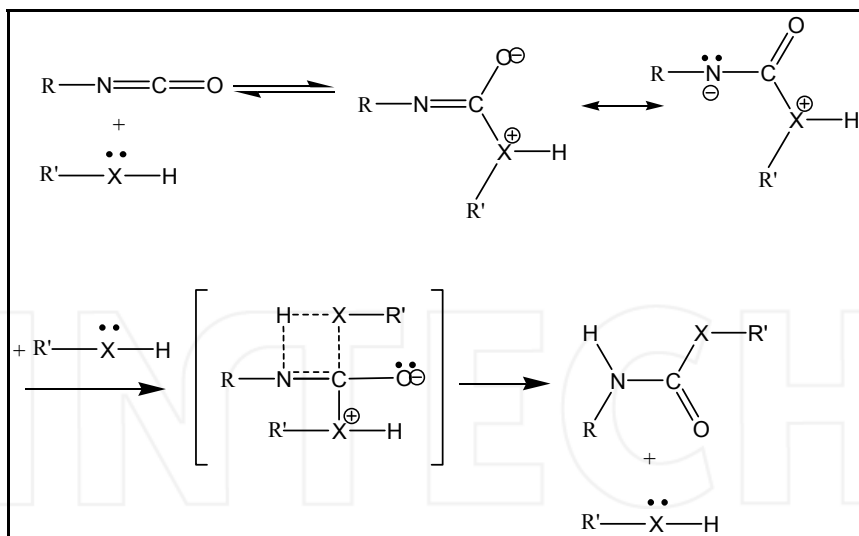

Scheme 9. Isocyanate reaction in the absence of a catalyst

As given in Scheme 9, in the reactions proceeding in the absence of a catalyst, the electrophilic carbon of the isocyanate is attacked by the nucleophilic centre of the active hydrogen compound; hydrogen is added to -NCO group. The reactivity of the -NCO

groups is increased due to the presence of the electron withdrawing groups, and decreases by the electron donating groups. While the aromatic isocyanates are more reactive than the aliphatic isocyanates, steric hindrance at $-NCO$ or HXR' groups reduce the reactivity.

The order of reactivity of active hydrogen compounds with isocyanates in uncatalyzed systems is as follows:

Aliphatic amines > aromatic amines > primary alcohols > water > secondary alcohol > tertiary alcohol > phenol > carboxylic acid > ureas > amides > urethanes.

4.2. Reaction in the presence of a catalyst

The isocyanate reactions of class (a) are also extremely susceptible to catalysis. The various isocyanate reactions are influenced to different extents by different catalysts. Many commercial applications of isocyanates utilize catalysed reactions. Tertiary amines, metal compounds like tin compounds (as mentioned earlier in the chapter) are most widely used catalysts for the reaction (Schemes 10 and 11). The mechanisms are similar to that of the uncatalyzed reaction (Scheme 9).

The tertiary amines and metal salts catalyse the reaction as follows:

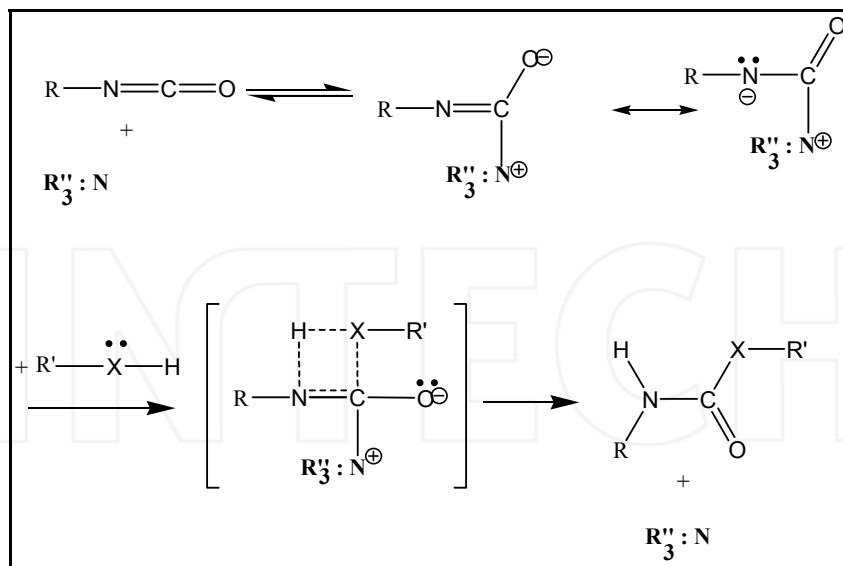

Scheme 10. Tertiary amine catalysed reaction

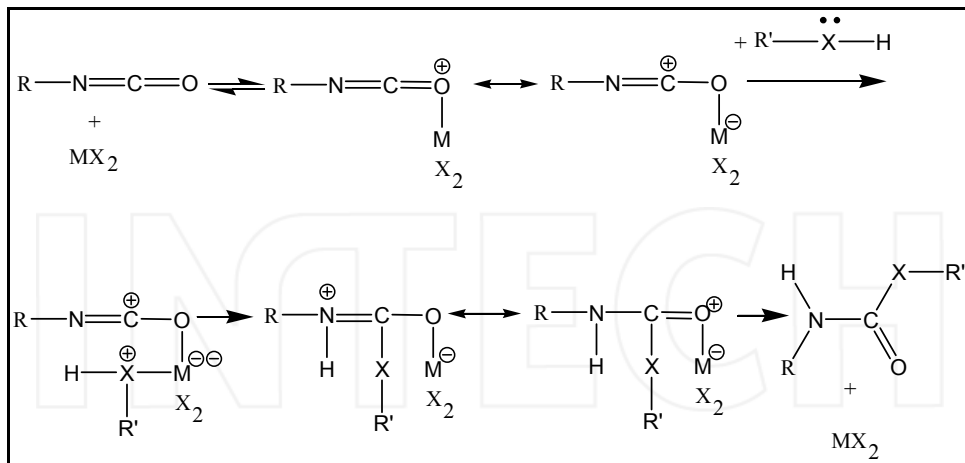

Scheme 11. Metal salts catalysed reaction

The catalytic activity of amines closely parallels to the base strength of the amines except when steric hindrance becomes pronounced. This catalyst is also effective for self-addition reactions while metal salt compounds generally have less influence; tin compounds are particularly poor catalysts in these reactions.

5. Hazards

Although PU are chemically inert in their fully reacted form, the risks of asthmatic symptoms arise on human exposure even in smaller concentrations due to the volatility associated with isocyanates. On exposure to flames, hazards of ignition are feared. Isocyanates may also be sensitive on our skin. Some isocyanates may also be anticipated as carcinogens. Thus, persons working with isocyanates must be equipped with proper protection devices such as gloves, masks, respirators, goggles, and others, as precautionary measures.

6. Conclusion

PU are thermoplastic and thermoset in nature. The type, position, and structure of both the isocyanate and polyol determine the progress of PU forming reactions as well as their properties and end-use applications. Hydrogen bonding also plays a key role in determining the properties of final PU product. Due to the associated health hazards, complete precautions are necessary while working with isocyanates. PU are available as one-pack or two-pack PU. PU dispersions, waterborne PU, PU Interpenetrating

Networks PU, hybrids and composites are used in various applications such as paints and coatings, adhesives, sealants, foams, absorbents, flame retardants, fuel binders, in automobiles, in biomedical applications (urological stenting practices, carriers of antituberculosis drugs, orthopaedics), extraction of metals, grouting technologies, crashworthiness, treatment of industry wastewater, cast elastomers, and others as also discussed in proceeding chapters.

Author details

Eram Sharmin and Fahmina Zafar*
*Materials Research Laboratory, Department of Chemistry,
 Jamia Millia Islamia (A Central University), New Delhi, India*

Acknowledgement

Dr Fahmina Zafar (Pool Officer) and Dr Eram Sharmin (Pool Officer) acknowledge Council of Scientific and Industrial Research, New Delhi, India for Senior Research Associateships against grant nos. 13(8385-A)/2010-POOL and 13(8464-A)/2011-10 POOL, respectively. They are also thankful to the Head, Department of Chemistry, Jamia Millia Islamia (A Central University), for providing support to carry out the work.

7. References

- Chattopadhyay D.K., Raju K.V.S.N. Structural Engineering of Polyurethane Coatings for High Performance Applications. *Progress in Polymer Science* 2007; 32: 352–418.
- Desroches M., Escouvois M., Auvergne R., Caillol S., Boutevin B. From Vegetable Oils to Polyurethanes: Synthetic Routes to Polyols and Main Industrial Products. *Polymer Reviews* 2012; 52 (1): 38–79.
- Lligadas G., Ronda J.C., Galia M., Cadiz V. Plant Oils as Platform Chemicals for Polyurethane Synthesis: Current State-of-the-Art. *Biomacromolecules* 2010; 11: 2825–2835.
- Malcolm P S. *Polymer Chemistry An Introduction*. 3rd Edn. New York: Oxford University Press, Oxford; 1999.
- Nylen P., Sunderland E. *Modern Surface Coatings*. London: John Wiley & Sons; 1965.
- Paul, S. *Surface Coating—Science and Technology*. New York: John Wiley & Sons; 1985.
- Petrović Z. S. Polyurethanes from Vegetable Oils. *Polymer Reviews* 2008; 48:109–155.

* Corresponding Author

Pfister D.P., Xia Y., Larock R.C. Recent Advances in Vegetable Oil-based Polyurethanes.
Chem Sus Chem 2011; 4(6):703–17.

Saunders K J. Organic Polymer Chemistry. 2nd Edn. New York: Chapman & Hall; 1981.
<http://en.wikipedia.org/wiki/Polyurethane> (accessed on 11th July 2012)

INTECH

INTECH