

We are IntechOpen, the world's leading publisher of Open Access books Built by scientists, for scientists

7,000

Open access books available

186,000

International authors and editors

200M

Downloads

Our authors are among the

154

Countries delivered to

TOP 1%

most cited scientists

12.2%

Contributors from top 500 universities



WEB OF SCIENCE™

Selection of our books indexed in the Book Citation Index
in Web of Science™ Core Collection (BKCI)

Interested in publishing with us?
Contact book.department@intechopen.com

Numbers displayed above are based on latest data collected.
For more information visit www.intechopen.com



Robust Adaptive Wavelet Neural Network Control of Buck Converters

Hamed Bouzari^{1,2}, Miloš Šramek^{1,2},
Gabriel Mistelbauer² and Ehsan Bouzari³

¹Austrian Academy of Sciences

²Vienna University of Technology

³Zanjan University

^{1,2}Austria

³Iran

1. Introduction

Robustness is of crucial importance in control system design because the real engineering systems are vulnerable to external disturbance and measurement noise and there are always differences between mathematical models used for design and the actual system. Typically, it is required to design a controller that will stabilize a plant, if it is not stable originally, and to satisfy certain performance levels in the presence of disturbance signals, noise interference, unmodelled plant dynamics and plant-parameter variations. These design objectives are best realized via the feedback control mechanism (Fig. 1), although it introduces in the issues of high cost (the use of sensors), system complexity (implementation and safety) and more concerns on stability (thus internal stability and stabilizing controllers) (Gu, Petkov, & Konstantinov, 2005). In abstract, a control system is robust if it remains stable and achieves certain performance criteria in the presence of possible uncertainties. The *robust design* is to find a controller, for a given system, such that the closed-loop system is robust.

In this chapter, the basic concepts and representations of a robust adaptive wavelet neural network control for the case study of buck converters will be discussed.

The remainder of the chapter is organized as follows: In section 2 the advantages of neural network controllers over conventional ones will be discussed, considering the efficiency of introduction of wavelet theory in identifying unknown dependencies. Section 3 presents an overview of the buck converter models. In section 4, a detailed overview of WNN methods is presented. Robust control is introduced in section 5 to increase the robustness against noise by implementing the error minimization. Section 6 explains the stability analysis which is based on adaptive bound estimation. The implementation procedure and results of AWNN controller are explained in section 7. The results show the effectiveness of the proposed method in comparison to other previous works. The final section concludes the chapter.

2. Overview of wavelet neural networks

The conventional Proportional Integral Derivative (PID) controllers have been widely used in industry due to their simple control structure, ease of design, and inexpensive cost (Ang,

Chong, & Li, 2005). However, successful applications of the PID controller require the satisfactory tuning of parameters according to the dynamics of the process. In fact, most PID controllers are tuned on-site. The lengthy calculations for an initial guess of PID parameters can often be demanding if we know a few about the plant, especially when the system is unknown.

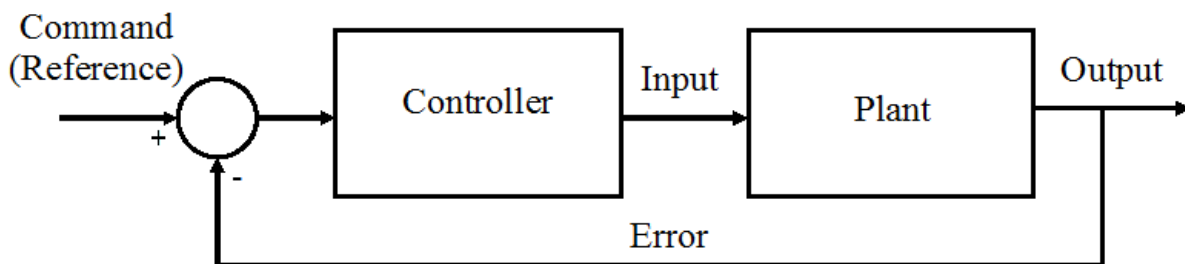

Fig. 1. Feedback control system design.

There has been considerable interest in the past several years in exploring the applications of Neural Network (NN) to deal with nonlinearities and uncertainties of the real-time control system (Sarangapani, 2006). It has been proven that artificial NN can approximate a wide range of nonlinear functions to any desired degree of accuracy under certain conditions (Sarangapani, 2006). It is generally understood that the selection of the NN training algorithm plays an important role for most NN applications. In the conventional gradient-descent-type weight adaptation, the sensitivity of the controlled system is required in the online training process. However, it is difficult to acquire sensitivity information for unknown or highly nonlinear dynamics. In addition, the local minimum of the performance index remains to be challenged (Sarangapani, 2006). In practical control applications, it is desirable to have a systematic method of ensuring the stability, robustness, and performance properties of the overall system. Several NN control approaches have been proposed based on Lyapunov stability theorem (Lim et al., 2009; Ziqian, Shih, & Qunjing, 2009). One main advantage of these control schemes is that the adaptive laws were derived based on the Lyapunov synthesis method and therefore it guarantees the stability of the under control system. However, some constraint conditions should be assumed in the control process, e.g., that the approximation error, optimal parameter vectors or higher order terms in a Taylor series expansion of the nonlinear control law, are bounded. Besides, the prior knowledge of the controlled system may be required, e.g., the external disturbance is bounded or all states of the controlled system are measurable. These requirements are not easy to satisfy in practical control applications.

NNs in general can identify patterns according to their relationship, responding to related patterns with a similar output. They are trained to classify certain patterns into groups, and then are used to identify the new ones, which were never presented before. NNs can correctly identify incomplete or similar patterns; it utilizes only absolute values of input variables but these can differ enormously, while their relations may be the same. Likewise we can reason identification of unknown dependencies of the input data, which NN should learn. This could be regarded as a pattern abstraction, similar to the brain functionality, where the identification is not based on the values of variables but only relations of these.

In the hope to capture the complexity of a process Wavelet theory has been combined with the NN to create Wavelet Neural Networks (WNN). The training algorithms for WNN

typically converge in a smaller number of iterations than the conventional NNs (Ho, Ping-Au, & Jinhua, 2001). Unlike the sigmoid functions used in conventional NNs, the second layer of WNN is a wavelet form, in which the translation and dilation parameters are included. Thus, WNN has been proved to be better than the other NNs in that the structure can provide more potential to enrich the mapping relationship between inputs and outputs (Ho, Ping-Au, & Jinhua, 2001). Much research has been done on applications of WNNs, which combines the capability of artificial NNs for learning from processes and the capability of wavelet decomposition (Chen & Hsiao, 1999) for identification and control of dynamic systems (Zhang, 1997). Zhang, 1997 described a WNN for function learning and estimation, and the structure of this network is similar to that of the radial basis function network except that the radial functions are replaced by orthonormal scaling functions. Also in this study, the family of basis functions for the RBF network is replaced by an orthogonal basis (i.e., the scaling functions in the theory of wavelets) to form a WNN. WNNs offer a good compromise between robust implementations resulting from the redundancy characteristic of non-orthogonal wavelets and neural systems, and efficient functional representations that build on the time-frequency localization property of wavelets.

3. Problem formulation

Due to the rapid development of power semiconductor devices in personal computers, computer peripherals, and adapters, the switching power supplies are popular in modern industrial applications. To obtain high quality power systems, the popular control technique of the switching power supplies is the Pulse Width Modulation (PWM) approach (Pressman, Billings, & Morey, 2009). By varying the duty ratio of the PWM modulator, the switching power supply can convert one level of electrical voltage into the desired level. From the control viewpoint, the controller design of the switching power supply is an intriguing issue, which must cope with wide input voltage and load resistance variations to ensure the stability in any operating condition while providing fast transient response. Over the past decade, there have been many different approaches proposed for PWM switching control design based on PI control (Alvarez-Ramirez et al., 2001), optimal control (Hsieh, Yen, & Juang, 2005), sliding-mode control (Vidal-Idiarte et al., 2004), fuzzy control (Vidal-Idiarte et al., 2004), and adaptive control (Mayosky & Cancelo, 1999) techniques. However, most of these approaches require adequately time-consuming trial-and-error tuning procedure to achieve satisfactory performance for specific models; some of them cannot achieve satisfactory performance under the changes of operating point; and some of them have not given the stability analysis. The motivation of this chapter is to design an Adaptive Wavelet Neural Network (AWNN) control system for the Buck type switching power supply. The proposed AWNN control system is comprised of a NN controller and a compensated controller. The neural controller using a WNN is designed to mimic an ideal controller and a robust controller is designed to compensate for the approximation error between the ideal controller and the neural controller. The online adaptive laws are derived based on the Lyapunov stability theorem so that the stability of the system can be guaranteed. Finally, the proposed AWNN control scheme is applied to control a Buck type switching power supply. The simulated results demonstrate that the proposed AWNN control scheme can achieve favorable control performance; even the switching power supply is subjected to the input voltage and load resistance variations.

Among the various switching control methods, PWM which is based on fast switching and duty ratio control is the most widely considered one. The switching frequency is constant and the duty cycle, $U(N)$ varies with the load resistance fluctuations at the N th sampling time. The output of the designed controller $U(N)$ is the duty cycle.

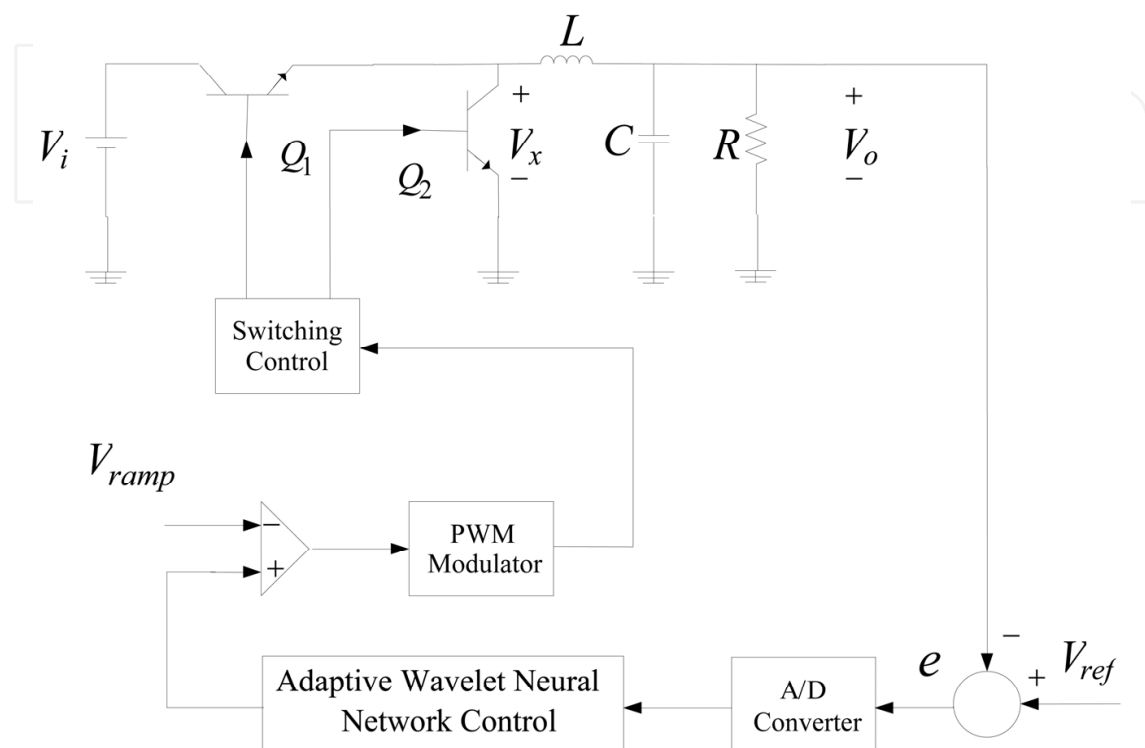

Fig. 2. Buck type switching power supply

This duty cycle signal is then sent to a PWM output stage that generates the appropriate switching pattern for the switching power supplies. A forward switching power supply (Buck converter) is discussed in this study as shown in Fig. 2, where V_i and V_o are the input and output voltages of the converter, respectively, L is the inductor, C is the output capacitor, R is the resistor and Q_1 and Q_2 are the transistors which control the converter circuit operating in different modes. Figure 1 shows a synchronous Buck converter. It is called a synchronous buck converter because transistor Q_2 is switched on and off synchronously with the operation of the primary switch Q_1 . The idea of a synchronous buck converter is to use a MOSFET as a rectifier that has very low forward voltage drop as compared to a standard rectifier. By lowering the diode's voltage drop, the overall efficiency for the buck converter can be improved. The synchronous rectifier (MOSFET Q_2) requires a second PWM signal that is the complement of the primary PWM signal. Q_2 is on when Q_1 is off and vice a versa. This PWM format is called Complementary PWM. When Q_1 is ON and Q_2 is OFF, V_i generates:

$$V_x = (V_i - V_{lost}) \quad (1)$$

where V_{lost} denotes the voltage drop occurring by transistors and represents the unmodeled dynamics in practical applications. The transistor Q_2 ensures that only positive voltages are

applied to the output circuit while transistor Q_1 provides a circulating path for inductor current. The output voltage can be expressed as:

$$\begin{cases} C \frac{dV_c(t)}{dt} = I_L - \frac{V_c(t)}{R} \\ L \frac{dI_L(t)}{dt} = U(t)V_x(t) - V_c(t) \\ V_o(t) = V_c(t) \end{cases} \quad (2)$$

It yields to a nonlinear dynamics which must be transformed into a linear one:

$$\frac{d^2V_o(t)}{dt^2} = -\frac{1}{LC}V_o(t) - \frac{1}{RC} \frac{dV_o(t)}{dt} + \frac{1}{LC}U(t)V_x(t) \quad (3)$$

Where, $V_x(t)/LC$, is the control gain which is a positive constant and $U(t)$ is the output of the controller. The control problem of Buck type switching power supplies is to control the duty cycle $U(t)$ so that the output voltage V_o can provide a fixed voltage under the occurrence of the uncertainties such as the wide input voltages and load variations. The output error voltage vector is defined as:

$$\mathbf{e}(t) = \begin{bmatrix} V_o(t) \\ \frac{dV_o(t)}{dt} \end{bmatrix} - \begin{bmatrix} V_d(t) \\ \frac{dV_d(t)}{dt} \end{bmatrix} \quad (4)$$

where V_d is the output desired voltage. The control law of the duty cycle is determined by the error voltage signal in order to provide fast transient response and small overshoot in the output voltage. If the system parameters are well known, the following ideal controller would transform the original nonlinear dynamics into a linear one:

$$U^*(t) = \frac{1}{V_x(t)} \left[V_o(t) + \frac{L}{R} \frac{dV_o(t)}{dt} + LC \frac{d^2V_d(t)}{dt^2} + LCK^T \mathbf{e}(t) \right] \quad (5)$$

If $\mathbf{K} = [k_2, k_1]^T$ is chosen to correspond to the coefficients of a Hurwitz polynomial, which ensures satisfactory behavior of the close-loop linear system. It is a polynomial whose roots lie strictly in the open left half of the complex plane, and then the linear system would be as follows:

$$\frac{d^2e(t)}{dt^2} + k_1 \frac{de(t)}{dt} + k_2 e(t) = 0 \Rightarrow \lim_{t \rightarrow \infty} e(t) = 0 \quad (6)$$

Since the system parameters may be unknown or perturbed, the ideal controller in (5) cannot be precisely implemented. However, the parameter variations of the system are difficult to be monitored, and the exact value of the external load disturbance is also difficult

to be measured in advance for practical applications. Therefore, an intuitive candidate of $U^*(t)$ would be an AWNN controller (Fig. 1):

$$U_{AWNN}(t) = U_{WNN}(t) + U_A(t) \quad (7)$$

Where $U_{WNN}(t)$ is a WNN controller which is rich enough to approximate the system parameters, and $U_A(t)$, is a robust controller. The WNN control is the main tracking controller that is used to mimic the computed control law, and the robust controller is designed to compensate the difference between the computed control law and the WNN controller.

Now the problem is divided into two tasks:

- How to update the parameters of WNN incrementally so that it approximates the system.
- How to apply $U_A(t)$ to guarantee global stability while WNN is approximating the system during the whole process.

The first task is not too difficult as long as WNN is equipped with enough parameters to approximate the system. For the second task, we need to apply the concept of a branch of nonlinear control theory called *sliding control* (Slotine & Li, 1991). This method has been developed to handle performance and robustness objectives. It can be applied to systems where the plant model and the control gain are not exactly known, but bounded.

The robust controller is derived from Lyapunov theorem to cope all system uncertainties in order to guarantee a stable control. Substituting (7) into (3), we get:

$$\frac{d^2V_o(t)}{dt^2} = -\frac{1}{LC}V_o(t) - \frac{1}{RC}\frac{dV_o(t)}{dt} + \frac{1}{LC}U_{AWNN}(t)V_x(t) \quad (8)$$

The error equation governing the system can be obtained by combining (6) and (8), i.e.

$$\frac{d^2e(t)}{dt^2} + k_1\frac{de(t)}{dt} + k_2e(t) = \frac{1}{LC}V_x(t)(U^*(t) - U_{WNN}(t) - U_A(t)) \quad (9)$$

4. Wavelet neural network controller

Feed forward NNs are composed of layers of neurons in which the input layer of neurons is connected to the output layer of neurons through one or more layers of intermediate neurons. The notion of a WNN was proposed as an alternative to feed forward NNs for approximating arbitrary nonlinear functions based on the wavelet transform theory, and a back propagation algorithm was adapted for WNN training. From the point of view of function representation, the traditional radial basis function (RBF) networks can represent any function that is in the space spanned by the family of basis functions. However, the basis functions in the family are generally not orthogonal and are redundant. It means that the RBF network representation for a given function is not unique and is probably not the most efficient. Representing a continuous function by a weighted sum of basis functions can be made unique if the basis functions are orthonormal.

It was proved that NNs can be designed to represent such expansions with desired degree of accuracy. NNs are used in function approximation, pattern classification and in data

mining but they could not characterize local features like jumps in values well. The local features may exist in time or frequency. Wavelets have many desired properties combined together like compact support, orthogonality, localization in time and frequency and fast algorithms. The improvement in their characterization will result in data compression and subsequent modification of classification tools.

In this study a two-layer WNN (Fig. 3), which is comprised of a product layer and an output layer, was adopted to implement the proposed WNN controller. The standard approach in sliding control is to define an integrated error function which is similar to a PID function. The control signal $U(t)$ is calculated in such way that the closed-loop system reaches a predefined sliding surface $S(t)$ and remains on this surface. The control signal $U(t)$ required for the system to remain on this sliding surface is called the equivalent control $U^*(t)$. This sliding surface is defined as follows:

$$S(t) = \left(\frac{d}{dt} + \hbar \right) e(t), \quad \hbar > 0 \quad (10)$$

where \hbar is a strictly positive constant. The equivalent control is given by the requirement $S(t) = 0$, it defines a time varying hyperplane in \mathfrak{R}^2 on which the tracking error vector $e(t)$ decays exponentially to zero, so that perfect tracking can be obtained asymptotically. Moreover, if we can maintain the following condition:

$$\frac{d|S(t)|}{dt} < -\eta \quad (11)$$

where η is a strictly positive constant. Then $|S(t)|$ will approach the hyperplane $|S(t)| = 0$ in a finite time less than or equal to $|S(t)|/\eta$. In other words, by maintain the condition in equation (11), $S(t)$ will approaches the sliding surface $S(t) = 0$ in a finite time, and then error, $e(t)$ will converge to the origin exponentially with a time constant $1/\hbar$. If $k_2 = 0$ and $\hbar = k_1$, then it yields from (6) and (10) that:

$$\frac{dS(t)}{dt} = \frac{d^2 e(t)}{dt^2} + k_1 \frac{de(t)}{dt} \quad (12)$$

The inputs of the WNN are S and dS/dt which in discrete domain it equals to $S(1 - z^{-1})$, where z^{-1} is a time delay. Note that the change of integrated error function $S(1 - z^{-1})$, is utilized as an input to the WNN to avoid the noise induced by the differential of integrated error function dS/dt . The output of the WNN is $U_{\text{WNN}}(t)$. A family of wavelets will be constructed by translations and dilations performed on a single fixed function called the mother wavelet. It is very effective way to use wavelet functions with time-frequency localization properties. Therefore if the dilation parameter is changed, the support region width of the wavelet function changes, but the number of cycles doesn't change; thus the first derivative of a Gaussian function $\Phi(x) = -x \exp(-x^2/2)$ was adopted as a mother wavelet in this study. It may be regarded as a differentiable version of the Haar mother wavelet, just as the sigmoid is a differentiable version of a step function, and it has the universal approximation property.

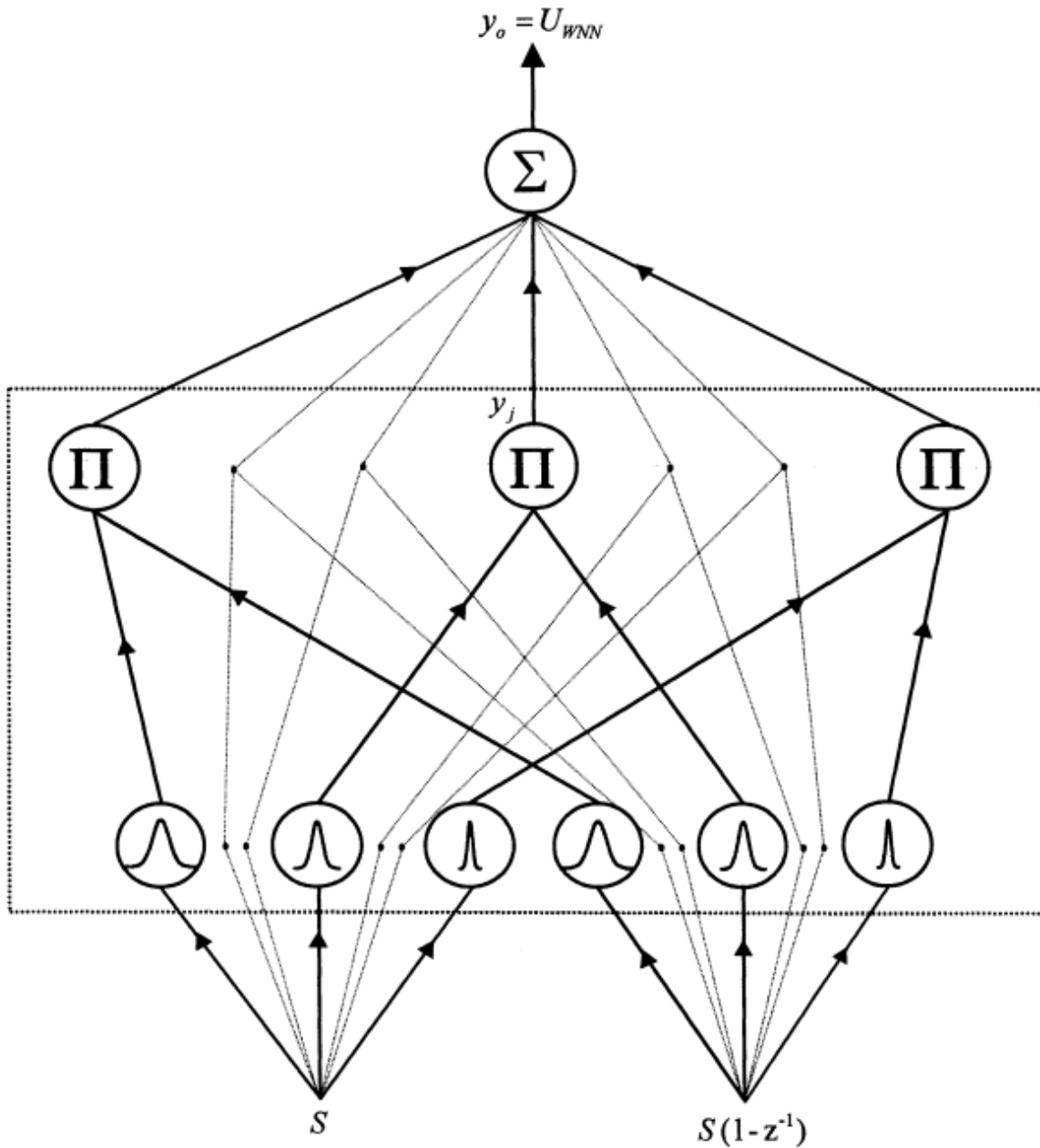

Fig. 3. Two-layer product WNN structure.

4.1 Input layer

$$net_i^1 = x_i^1; \quad y_i^1 = f_i^1(net_i^1) = net_i^1, \quad i = 1, 2 \tag{13}$$

where $i = 1, 2$ indicates as the number of layers.

4.2 Wavelet layer

A family of wavelets is constructed by translations and dilations performed on the mother wavelet. In the mother wavelet layer each node performs a wavelet Φ_j that is derived from its mother wavelet. For the j th node:

$$net_j^2 := \frac{x_i - m_{ij}}{d_{ij}}, \quad y_j^2 = f_j^2(net_j^2) = \prod_{i=1}^2 \Phi_j(net_j^2), \quad j = 1, 2, \dots, n_M \quad (14)$$

There are many kinds of wavelets that can be used in WNN. In this study, the first derivative of a Gaussian function is selected as a mother wavelet, as illustrated why.

4.3 Output layer

The single node in the output layer is labeled as Σ , which computes the overall output as the summation of all input signals.

$$net_0^3 = \sum_k^{n_M} a_k^3 \cdot y_k^3, \quad y_0^3 = f_0^3(net_0^3) = net_0^3 \quad (15)$$

The output of the last layer is U_{WNN} , respectively. Then the output of a WNN can be represented as:

$$U_{WNN}(S, M, D, \Theta) = \Theta^T \Gamma \quad (16)$$

where $\Gamma = [y_1^3, y_2^3, \dots, y_{n_M}^3]^T$, $\Theta = [a_1, a_2, \dots, a_{n_M}]^T$, $M = [m_1, m_2, \dots, m_{n_M}]^T$ and $D = [d_1, d_2, \dots, d_{n_M}]^T$.

5. Robust controller

First we begin with translating a robust control problem into an optimal control problem. Since we know how to solve a large class of optimal control problems, this optimal control approach allows us to solve some robust control problems that cannot be easily solved otherwise. By the universal approximation theorem, there exists an optimal neural controller $U_{nc}(t)$ such that (Lin, 2007):

$$\varepsilon = U_{nc}(t) - U^*(t) \quad (17)$$

To develop the robust controller, first, the minimum approximation error is defined as follows:

$$\begin{aligned} \varepsilon &= U_{WNN}^*(S, M^*, D^*, \Theta^*) - U^*(t) \\ &= \Theta^{*T} \Gamma^* - U^*(t) \end{aligned} \quad (18)$$

Where M^*, D^*, Θ^* are optimal network parameter vectors, achieve the minimum approximation error. After some straightforward manipulation, the error equation governing the closed-loop system can be obtained.

$$\dot{S}(t) = \frac{1}{LC} V_x(t) (U^*(t) - U_{WNN}(t) - U_A(t)) \quad (19)$$

Define \tilde{U}_{WNN} as:

$$\begin{aligned}\tilde{U}_{WNN} &= U^*(t) - U_{WNN}(t) = U_{WNN}^*(t) - U_{WNN}(t) - \varepsilon \\ &= \Theta^{*T} \Gamma - \Theta^T \Gamma - \varepsilon\end{aligned}\quad (20)$$

For simplicity of discussion, define $\tilde{\Theta} = \Theta^* - \Theta$; $\tilde{\Gamma} = \Gamma^* - \Gamma$ to obtain a rewritten form of (20):

$$\tilde{U}_{WNN} = \Theta^{*T} \tilde{\Gamma} + \tilde{\Theta}^T \Gamma - \varepsilon \quad (21)$$

In this study, a method is proposed to guarantee closed-loop stability and perfect tracking performance, and to tune translations and dilations of the wavelets online. The linearization technique was employed to transform the nonlinear wavelet functions into partially linear form to obtain the expansion of $\tilde{\Gamma}$ in a Taylor series:

$$\tilde{\Gamma} = \begin{bmatrix} \tilde{y}_1 \\ \tilde{y}_2 \\ \vdots \\ \tilde{y}_{n_M} \end{bmatrix} = \begin{bmatrix} \frac{\partial y_1}{\partial M} \\ \frac{\partial y_2}{\partial M} \\ \vdots \\ \frac{\partial y_{n_M}}{\partial M} \end{bmatrix} \tilde{M} + \begin{bmatrix} \frac{\partial y_1}{\partial D} \\ \frac{\partial y_2}{\partial D} \\ \vdots \\ \frac{\partial y_{n_M}}{\partial D} \end{bmatrix} \tilde{D} + H \quad (22)$$

$$\tilde{\Gamma} = A\tilde{M} + B\tilde{D} + H \quad (23)$$

Where $\tilde{M} = M^* - M$; $\tilde{D} = D^* - D$; H is a vector of higher order terms, and:

$$A = \begin{bmatrix} \frac{\partial y_1}{\partial M} & \frac{\partial y_2}{\partial M} & \dots & \frac{\partial y_{n_M}}{\partial M} \end{bmatrix}^T \quad (24)$$

$$B = \begin{bmatrix} \frac{\partial y_1}{\partial D} & \frac{\partial y_2}{\partial D} & \dots & \frac{\partial y_{n_M}}{\partial D} \end{bmatrix}^T \quad (25)$$

Substituting (23) into (21), it is revealed that:

$$\begin{aligned}\tilde{U}_{WNN} &= (\Theta + \tilde{\Theta})^T \tilde{\Gamma} + \tilde{\Theta}^T \Gamma - \varepsilon \\ &= \Theta^T (A\tilde{M} + B\tilde{D} + H) + \tilde{\Theta}^T \tilde{\Gamma} + \tilde{\Theta}^T \Gamma - \varepsilon \\ &= \tilde{\Theta}^T \Gamma + \Theta^T A\tilde{M} + \Theta^T B\tilde{D} + \psi\end{aligned}\quad (26)$$

Where the lumped uncertainty $\psi = \tilde{\Theta}^T \tilde{\Gamma} + \tilde{\Theta}^T \Gamma - \varepsilon$ is assumed to be bounded by $|\psi| < \rho$, in which $|\cdot|$ is the absolute value and ρ is a given positive constant.

$$\tilde{\rho}(t) = \hat{\rho}(t) - \rho \quad (27)$$

6. Stability analysis

System performance to be achieved by control can be characterized either as stability or optimality which are the most important issues in any control system. Briefly, a system is said to be stable if it would come to its equilibrium state after any external input, initial conditions, and/or disturbances which have impressed the system. An unstable system is of no practical value. The issue of stability is of even greater relevance when questions of safety and accuracy are at stake as Buck type switching power supplies. The stability test for WNN control systems, or lack of it, has been a subject of criticism by many control engineers in some control engineering literature. One of the most fundamental methods is based on Lyapunov's method. It shows that the time derivative of the Lyapunov function at the equilibrium point is negative semi definite. One approach is to define a Lyapunov function and then derive the WNN controller architecture from stability conditions (Lin, Hung, & Hsu, 2007).

Define a Lyapunov function as:

$$V_A(S(t), \tilde{\rho}(t), \tilde{\Theta}, \tilde{M}, \tilde{D}) = \frac{1}{2} S^2(t) + \frac{1}{LC} V_x(t) \tilde{\rho}^2(t) + \frac{1}{LC} V_x(t) \tilde{\Theta}^T \tilde{\Theta} + \frac{1}{LC} V_x(t) \tilde{M}^T \tilde{M} + \frac{1}{LC} V_x(t) \tilde{D}^T \tilde{D} \quad (28)$$

where λ, η_1, η_2 and η_3 are positive learning-rate constants. Differentiating (28) and using (19), it is concluded that:

$$\dot{V}_A = S(t) \frac{1}{LC} V_x(t) \left[U^*(t) - U_{WNN}(t) - U_A(t) \right] + \frac{1}{LC} V_x(t) \tilde{\rho}(t) \dot{\tilde{\rho}}(t) - \frac{1}{LC} V_x(t) \left[\frac{1}{\eta_1} \tilde{\Theta}^T \dot{\tilde{\Theta}} + \frac{1}{\eta_2} \tilde{M}^T \dot{\tilde{M}} + \frac{1}{\eta_3} \tilde{D}^T \dot{\tilde{D}} \right] \quad (29)$$

For achieving $\dot{V}_A \leq 0$, the adaptive laws and the compensated controller are chosen as:

$$\dot{\tilde{\Theta}} = \eta_1 S(t) \Gamma, \quad \dot{\tilde{M}} = \eta_2 S(t) A \tilde{\Theta} \quad \text{and} \quad \dot{\tilde{D}} = \eta_3 S(t) B \tilde{\Theta} \quad (30)$$

$$U_A(t) = \hat{\rho}(t) \text{sgn}(S(t)) \quad (31)$$

$$\dot{\hat{\rho}}(t) = \lambda |S(t)| \quad (32)$$

If the adaptation laws of the WNN controller are chosen as (30) and the robust controller is designed as (31), then (29) can be rewritten as follows:

$$\begin{aligned}\dot{V}_A &= \frac{1}{LC}V_x(t)S(t)\psi - \rho\frac{1}{LC}V_x(t)|S(t)| \leq \frac{1}{LC}V_x(t)|S(t)|\psi - \rho\frac{1}{LC}V_x(t)|S(t)| \\ &= \frac{1}{LC}V_x(t)|S(t)|[\psi - \rho] \leq 0\end{aligned}\quad (33)$$

Since $\dot{V}_A \leq 0$, V_A is negative semi definite:

$$V_A(S(t), \tilde{\rho}(t), \tilde{\theta}, \tilde{M}, \tilde{D}) \leq V_A(S(0), \tilde{\rho}(0), \tilde{\theta}, \tilde{M}, \tilde{D}) \quad (34)$$

Which implies that $S(t)$, $\tilde{\theta}$, \tilde{M} and \tilde{D} are bounded. By using Barbalat's lemma (Slotine & Li, 1991), it can be shown that $t \rightarrow \infty \Rightarrow S(t) \rightarrow 0$. As a result, the stability of the system can be guaranteed. Moreover, the tracking error of the control system, e , will converge to zero according to $S(t) \rightarrow 0$.

It can be verified that the proposed system not only guarantees the stable control performance of the system but also no prior knowledge of the controlled plant is required in the design process. Since the WNN has introduced the wavelet decomposition property into a general NN and the adaptation laws for the WNN controller are derived in the sense of Lyapunov stability, the proposed control system has two main advantages over prior ones: faster network convergence speed and stable control performance.

The adaptive bound estimation algorithm in (34) is always a positive value, and tracking error introduced by any uncertainty, such as sensor error or accumulation of numerical error, will cause the estimated bound $\hat{\rho}(t)$ increase unless the integrated error function $S(t)$ converges quickly to zero. These results that the actuator will eventually be saturated and the system may be unstable. To avoid this phenomenon in practical applications, an estimation index I is introduced in the bound estimation algorithm as $\hat{\rho}(t) = I\lambda|S(t)|$. If the magnitude of integrated error function is small than a predefined value S_0 , the WNN controller dominates the control characteristic; therefore, the control gain of the robust controller is fixed as the preceding adjusted value (i.e. $I = 0$). However, when the magnitude of integrated error function is large than the predefined value S_0 , the deviation of the states from the reference trajectory will require a continuous updating of, which is generated by the estimation algorithm (i.e. $I = 1$), for the robust controller to steer the system trajectory quickly back into the reference trajectory (Bouzari, Moradi, & Bouzari, 2008).

7. Numerical simulation results

In the first part of this section, AWNN results are presented to demonstrate the efficiency of the proposed approach. The performance of the proposed AWNN controlled system is compared in contrast with two controlling schemes, i.e. PID compensator and NN Predictive Controller (NNPC). The most obvious lack of these conventional controllers is that they cannot adapt themselves with the system new state variations than what they were designed based on at first. In this study, some parameters may be chosen as fixed constants, since they are not sensitive to experimental results. The principal of determining the best parameter values is based on the perceptual quality of the final results. We are most interested in four major characteristics of the closed-loop step response. They are: *Rise Time*: the time it takes for the plant output to rise beyond 90% of the desired level for the first time;

Overshoot: how much the peak level is higher than the steady state, normalized against the steady state; *Settling Time*: the time it takes for the system to converge to its steady state. *Steady-state Error*: the difference between the steady-state output and the desired output. Specifically speaking, controlling results are more preferable with the following characteristics:

Rise Time, Overshoot, Settling Time and Steady-state Error: as least as possible

7.1 AWNN controller

Here in this part, the controlling results are completely determined by the following parameters which are listed in Table 1. The converter runs at a switching frequency of 20 KHz and the controller runs at a sampling frequency of 1 KHz. Experimental cases are addressed as follows: Some load resistance variations with step changes are tested: 1) from 20Ω to 4Ω at slope of $300ms$, 2) from 4Ω to 20Ω at slope of $500ms$, and 3) from 20Ω to 4Ω at slope of $700ms$. The input voltage runs between $19V$ and $21V$ randomly.

C	L	k_1	η_1	η_2	η_3	λ	S_0	n_M
2.2mF	0.5mH	2	0.001	0.001	0.001	8	0.1	7

Table 1. Simulation Parameters.

At the first stage, the reference is chosen as a Step function with amplitude of 3 V.

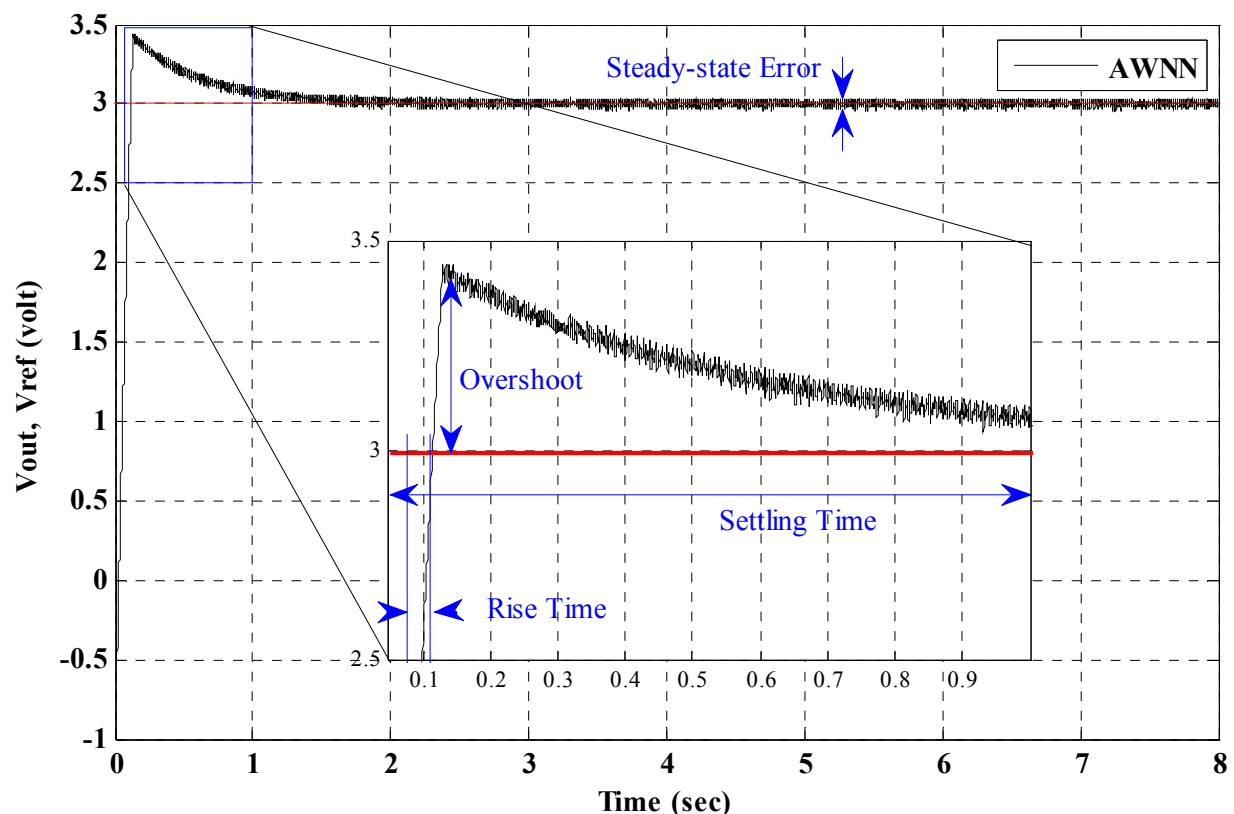

Fig. 4. Output Voltage, Command(reference) Voltage.

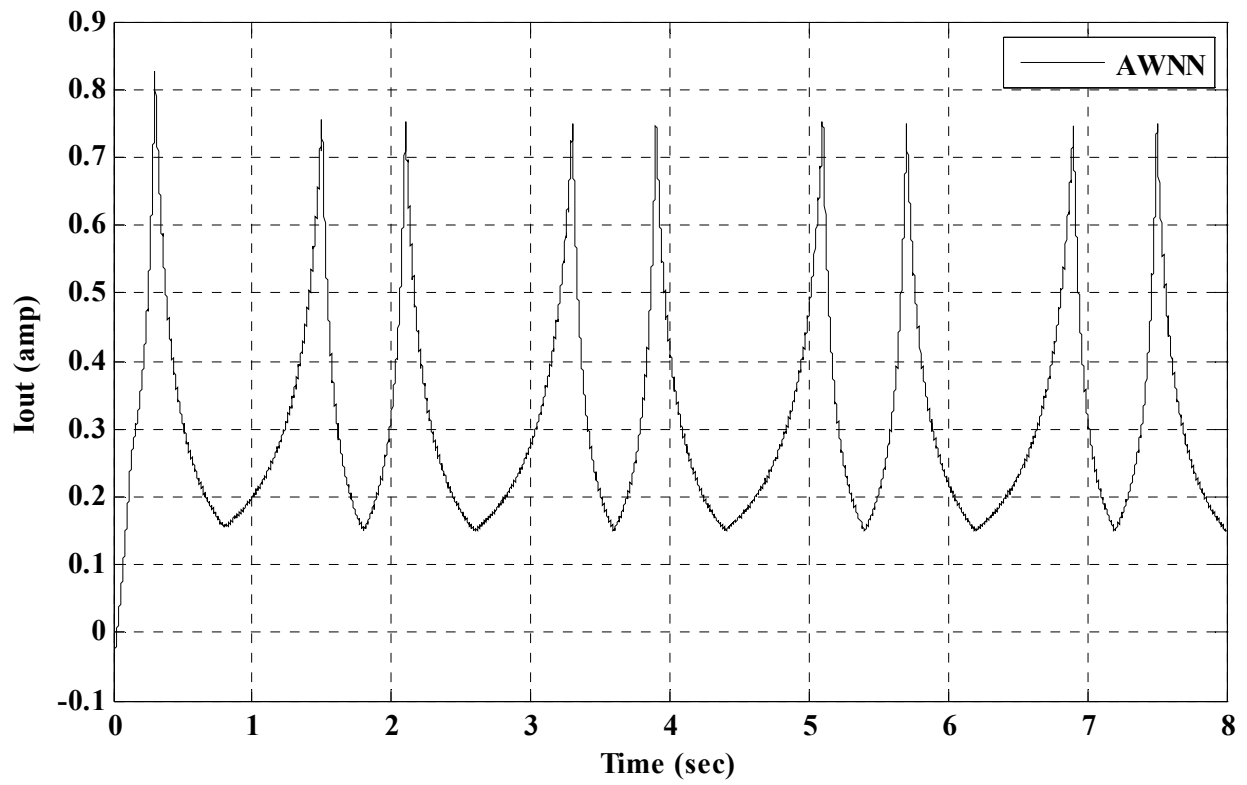

Fig. 5. Output Current.

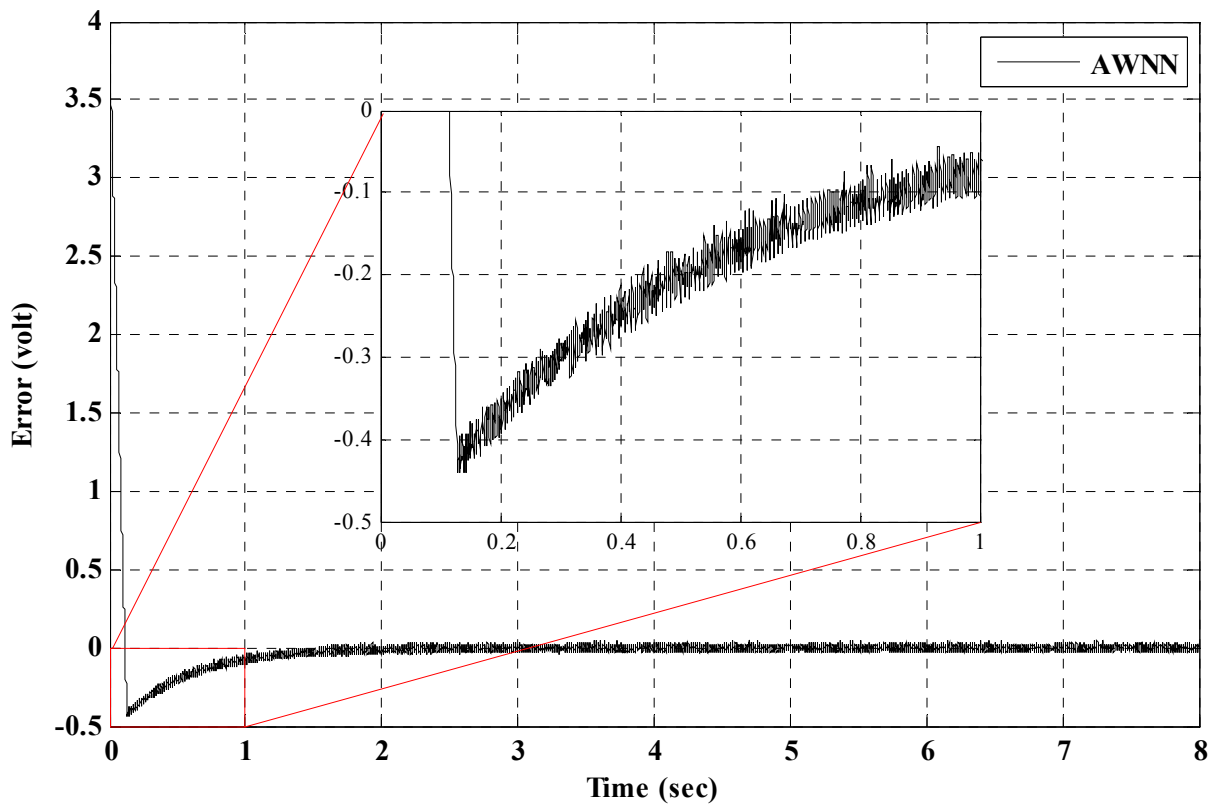

Fig. 6. Error Signal.

At the second stage, the command is a burst signal which changes from zero to 2 V with the period of 3 seconds and vice versa, repetitively. Results which are shown in Fig. 7 to Fig. 9 express that the output voltage follows the command in an acceptable manner from the beginning. It can be seen that after each step controller learns the system better and therefore adapts well more. If the input command has no discontinuity, the controller can track the command without much settling time. Big jumps in the input command have a great negative impact on the controller. It means that to get a fast tracking of the input commands, the different states of the command must be continues or have discontinuities very close to each other.

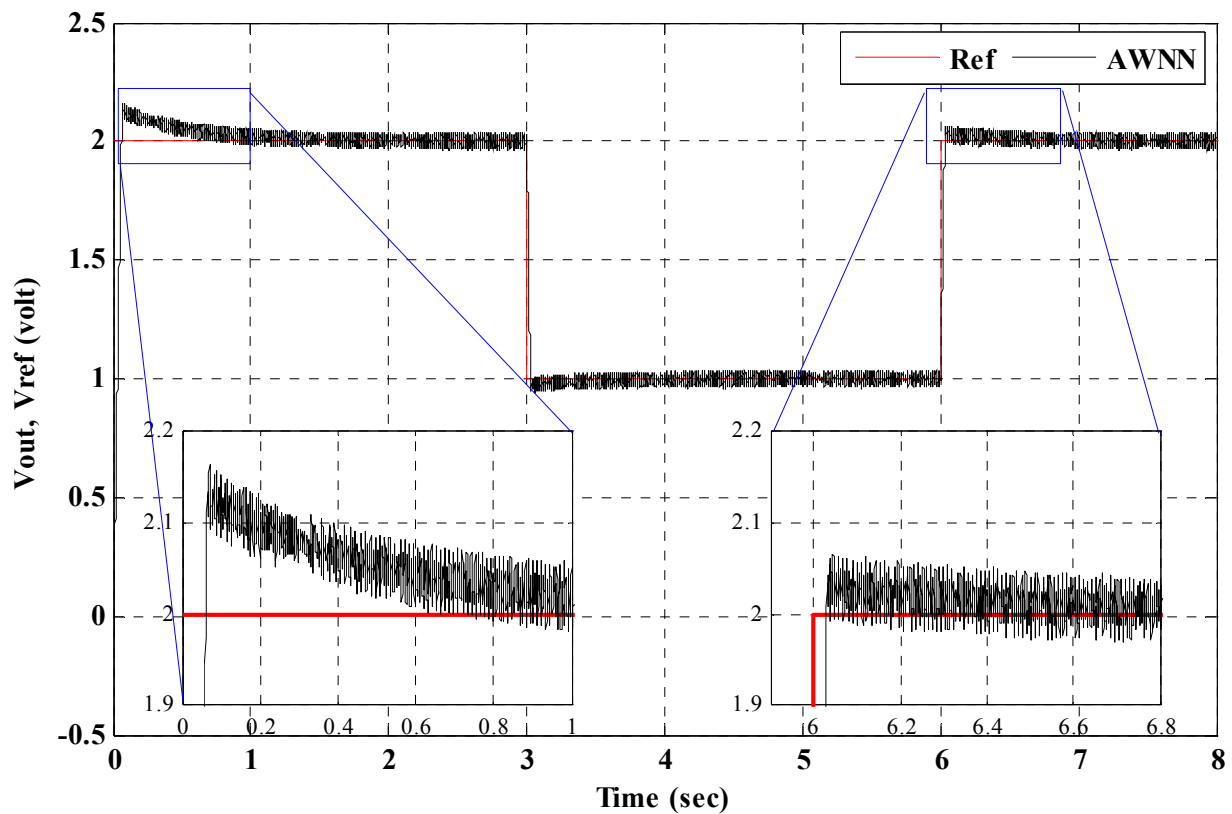

Fig. 7. Output Voltage, Command(reference) Voltage.

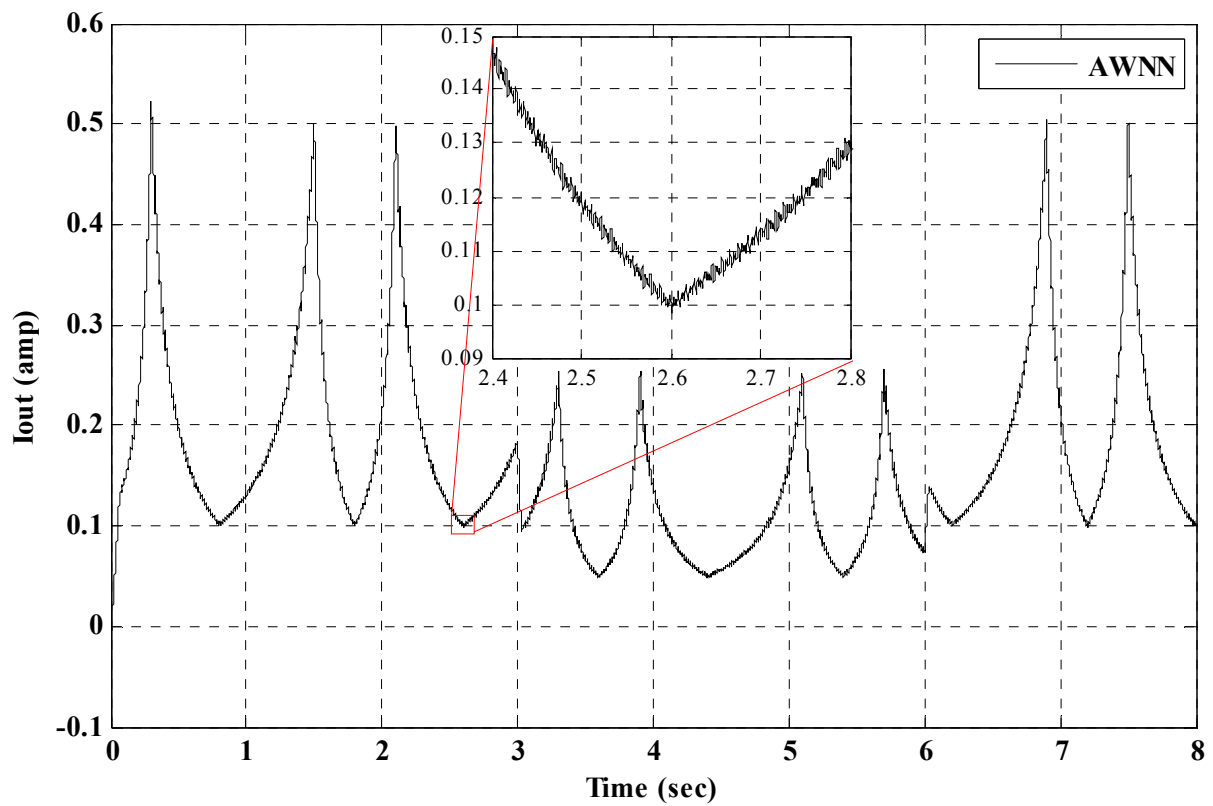

Fig. 8. Output Current.

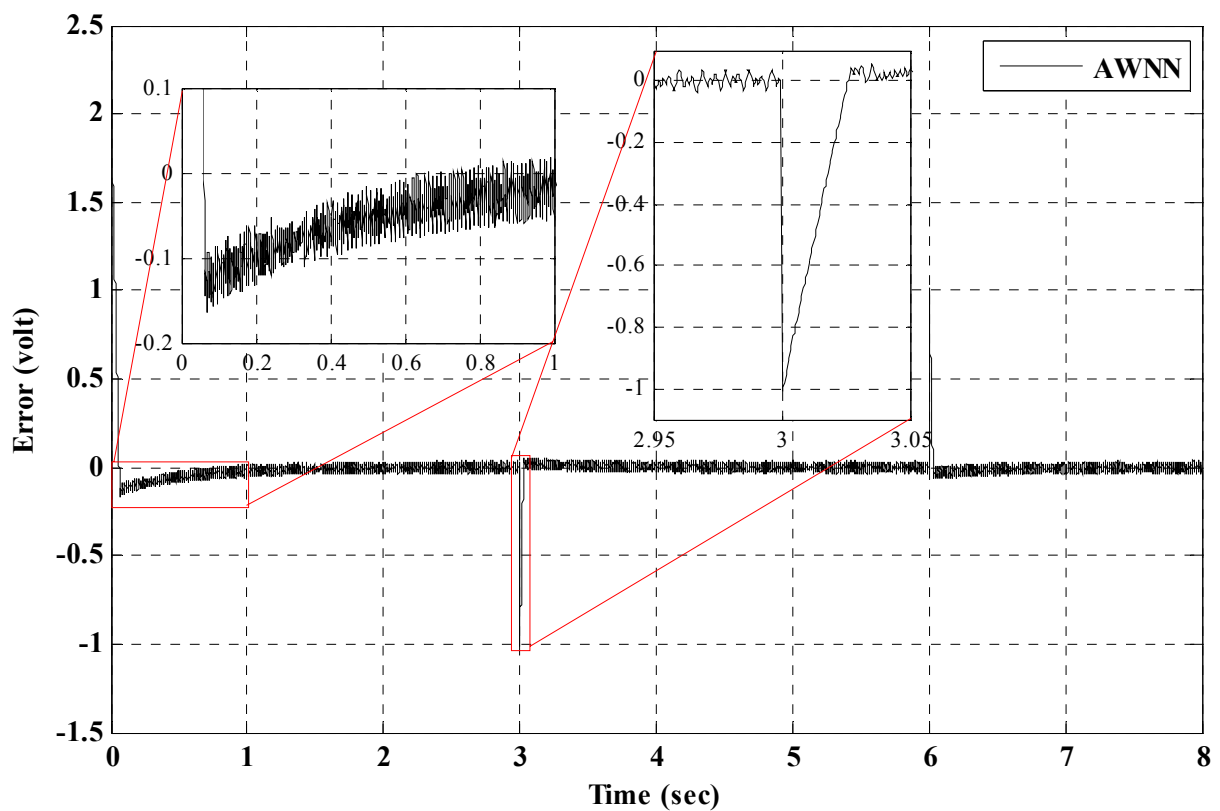

Fig. 9. Error Signal.

At the third stage, to show the well behavior of the controller, the output voltage follows the *Chirp* signal command perfectly, as it is shown in Fig. 10 to Fig. 12.

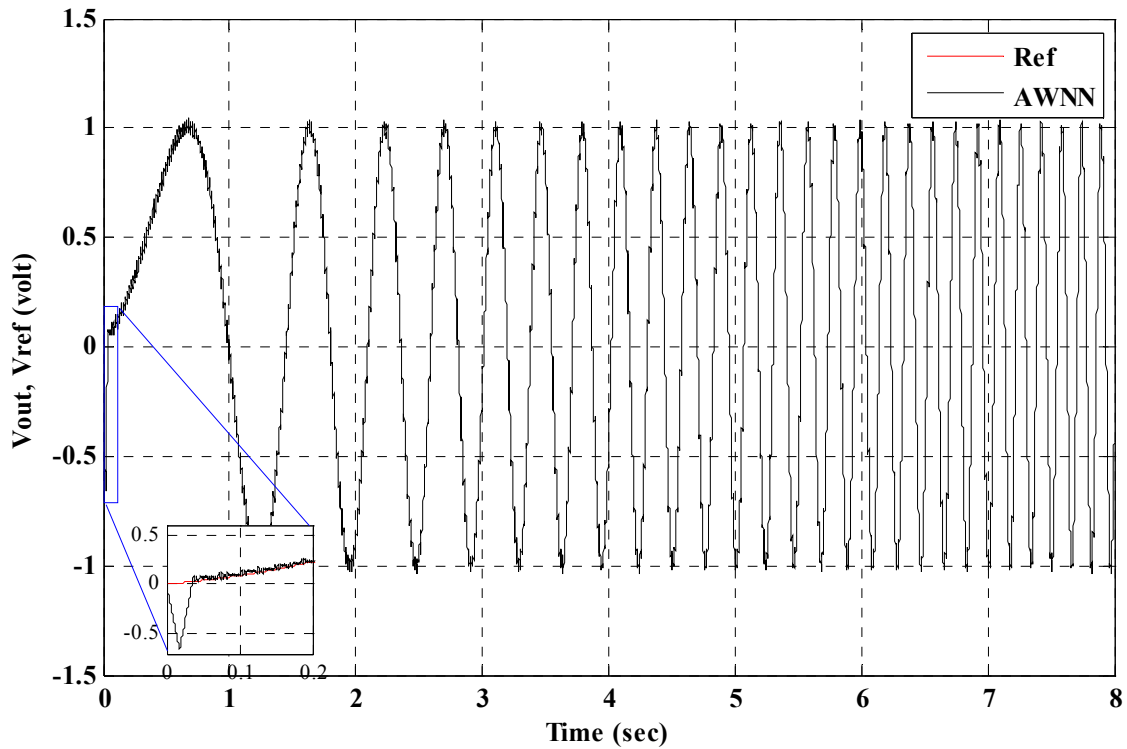

Fig. 10. Output Voltage, Command(reference) Voltage.

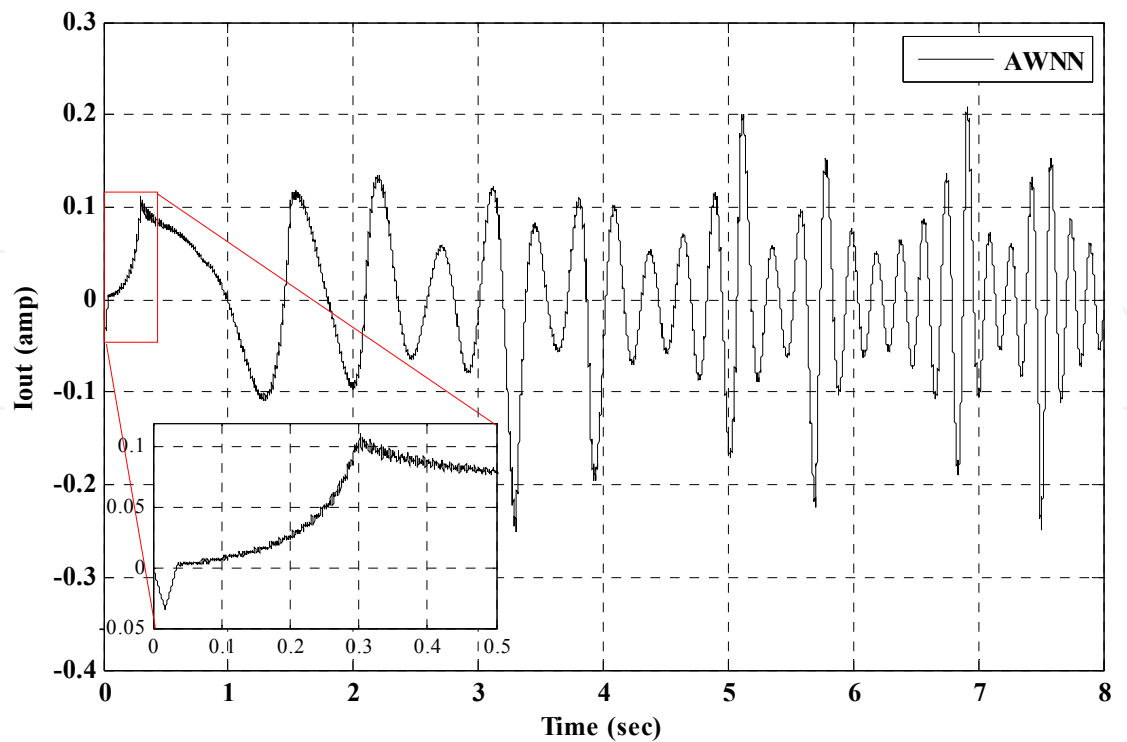

Fig. 11. Output Current.

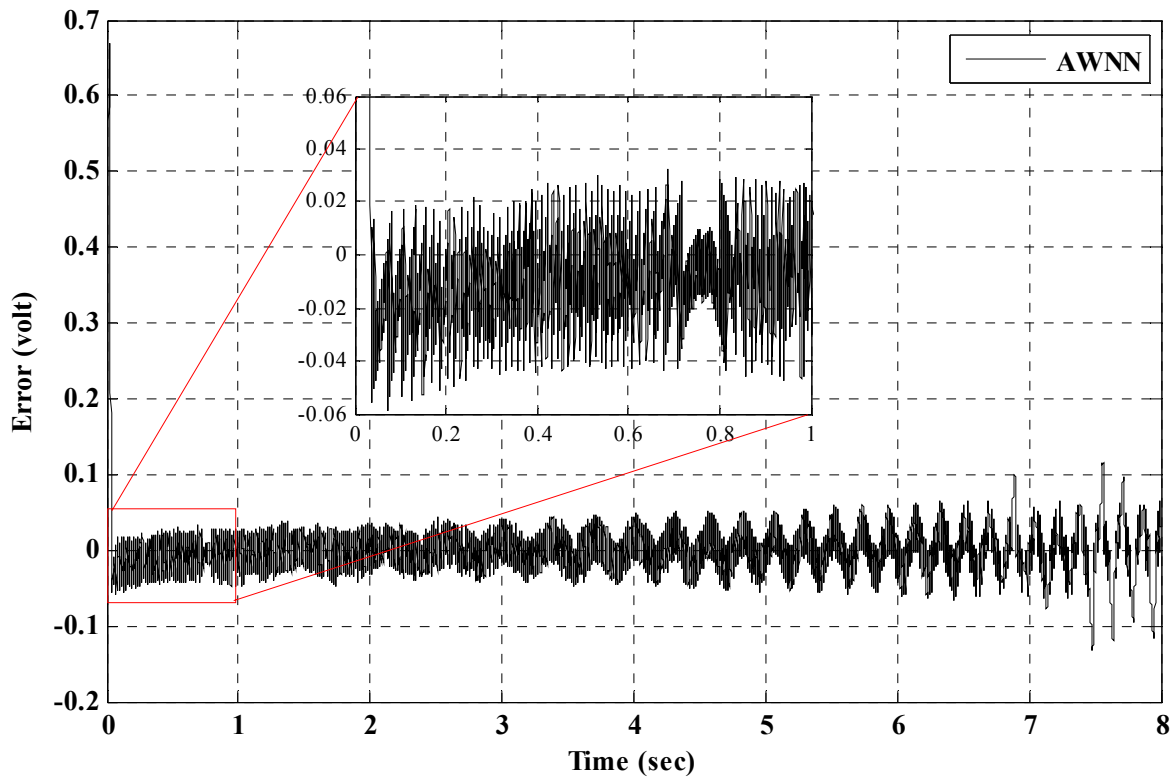

Fig. 12. Error Signal.

7.2 NNPC

To compare the results with other adaptive controlling techniques, Model Predictive Controller (MPC) with NN as its model descriptor (or NNPC), was implemented. The name NNPC stems from the idea of employing an explicit NN model of the plant to be controlled which is used to predict the future output behavior. This technique has been widely adopted in industry as an effective means to deal with multivariable constrained control problems. This prediction capability allows solving optimal control problems on-line, where tracking error, namely the difference between the predicted output and the desired reference, is minimized over a future horizon, possibly subject to constraints on the manipulated inputs and outputs. Therefore, the first stage of NNPC is to train a NN to represent the forward dynamics of the plant. The prediction error between the plant output and the NN output is used as the NN training signal (Fig. 14). The NN plant model can be trained offline by using the data collected from the operation of the plant.

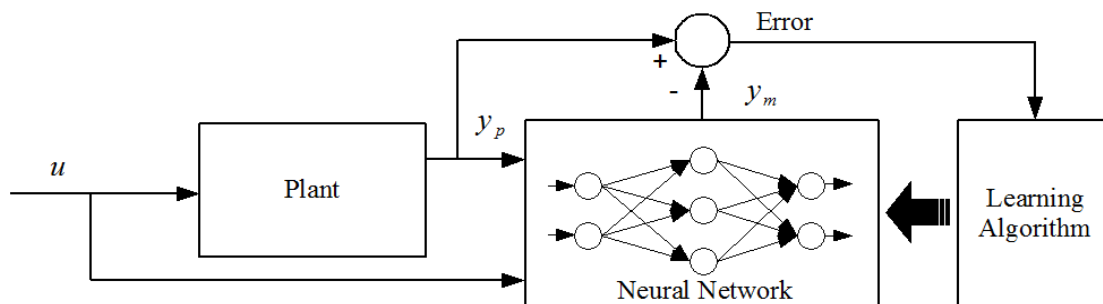

Fig. 13. NN Plant Model Identification.

The MPC method is based on the receding horizon technique. The NN model predicts the plant response over a specified time horizon. The predictions are used by a numerical optimization program to determine the control signal that minimizes the following performance criterion over the specified horizon: (Fig. 15)

$$J = \sum_{j=N_1}^{N_2} (y_r(t+j) - y_m(t+j))^2 + \rho \sum_{j=1}^{N_u} (u'(t+j-1) - u'(t+j-2))^2 \quad (35)$$

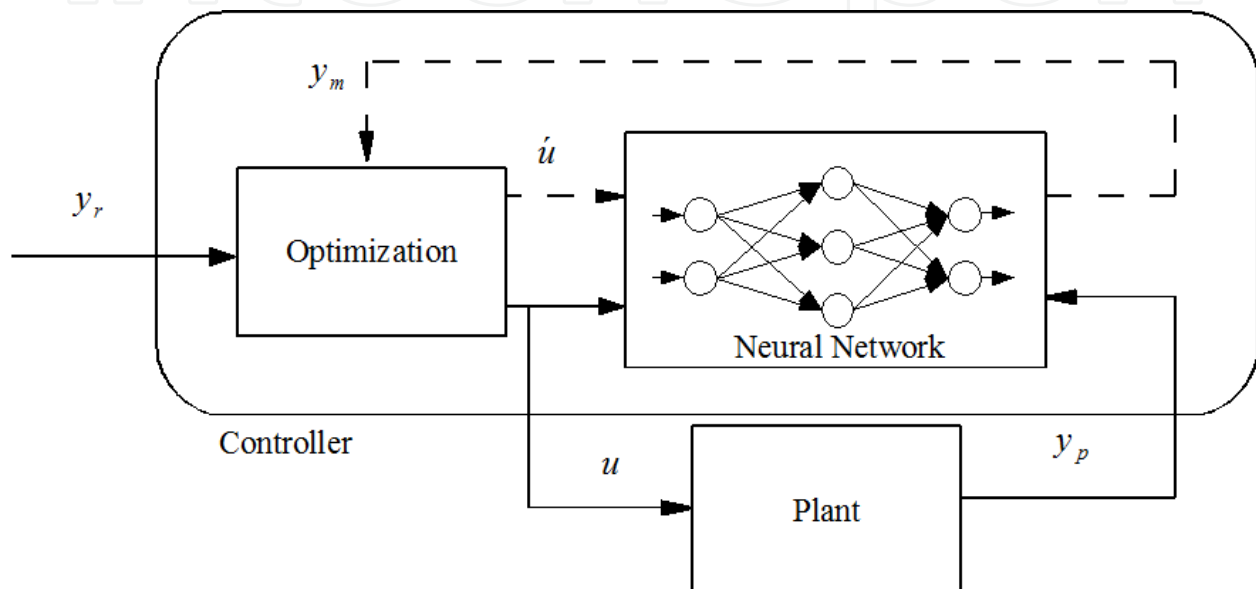

Fig. 14. NNPC Block Diagram.

where N_1 , N_2 , and N_u define the horizons over which the tracking error and the control increments are evaluated. The u' variable is the tentative control signal, y_r is the desired response, and y_m is the network model response. The ρ value determines the contribution that the sum of the squares of the control increments has on the performance index. The following block diagram illustrates the MPC process. The controller consists of the NN plant model and the optimization block. The optimization block determines the values of u' that minimize J , and then the optimal u is input to the plant.

N_2	N_u	ρ	Hidden Layers	Delayed Inputs	Delayed Outputs	Training Algorithm	Iterations
5	2	0.05	30	10	20	Levenberg-Marquardt Optimization	5

Table 3. NNPC Simulation Parameters.

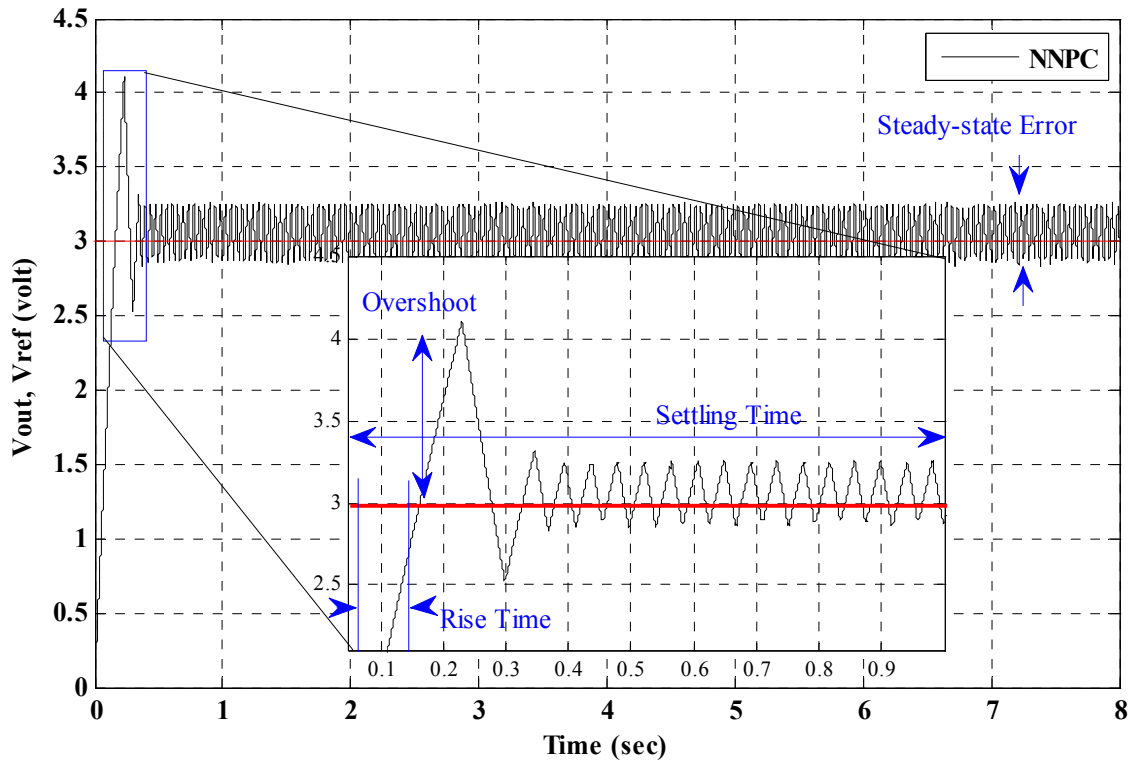

Fig. 15. Output Voltage, Command(reference) Voltage of NNPC.

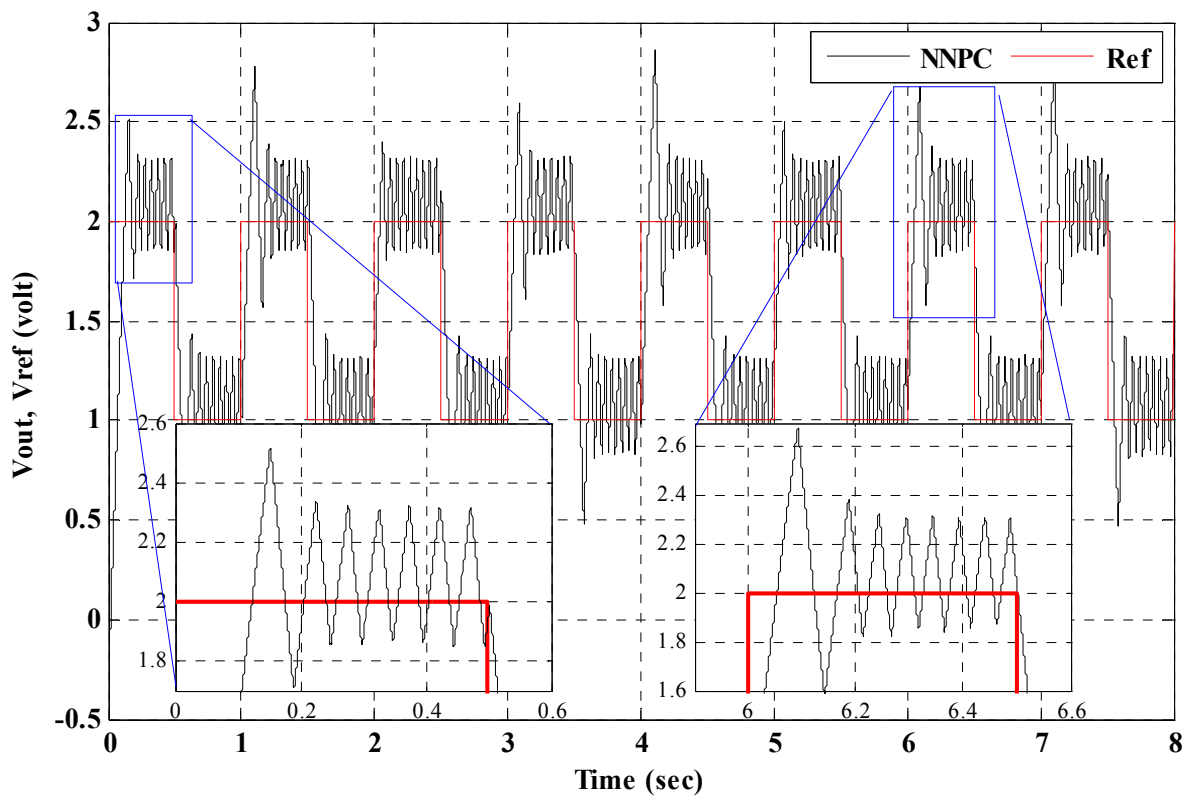

Fig. 16. Output Voltage, Command(reference) Voltage of NNPC

7.3 PID controller

Based on the power stages which were defined in the previous experiments, a nominal second-order PID compensator (controller) can be designed for the output voltage feedback loop, using small-signal analysis, to yield guaranteed stable performance. A generic second-order PID compensator is considered with the following transfer function:

$$G(z) = K + \frac{R_1}{z-1} + \frac{R_2}{z-P} \quad (36)$$

It is assumed that sufficient information about the nominal power stage (i.e., at system startup) is known such that a conservative compensator design can be performed. The following parameters were used for system initialization of the compensator: $K = 16.5924$, $R_1 = 0.0214$, $R_2 = -15.2527$ and $P = 0$. Figure 17 shows the Bode plot of the considered PID compensator. The output voltages with two different reference signals are shown in Fig. 18 and Fig. 19. As you can see it cannot get better after some times, because it is not adaptive to system variations, but on the other hand its convergence is quite good from the beginning.

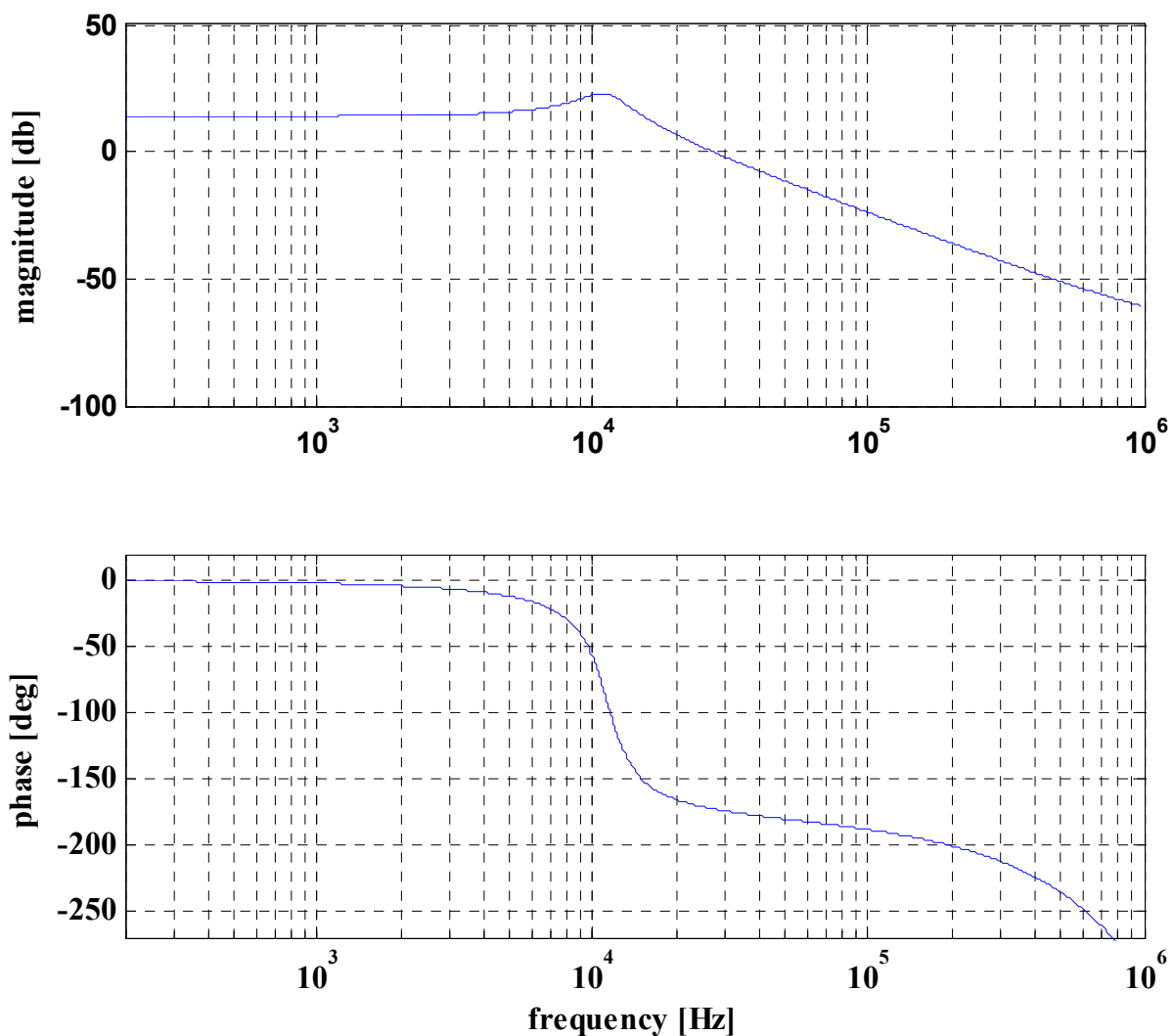

Fig. 17. Bode plot of the PID controller.

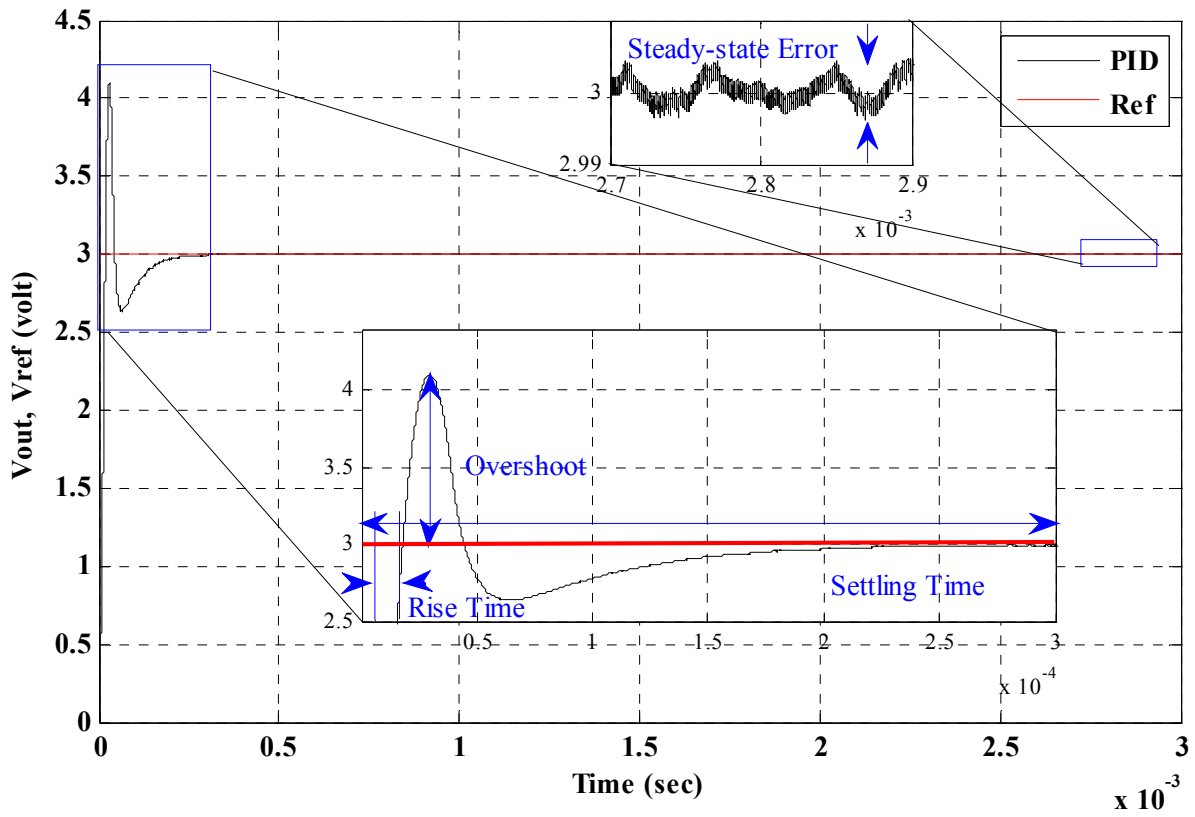

Fig. 18. Output Voltage, Command(reference) Voltage of PID.

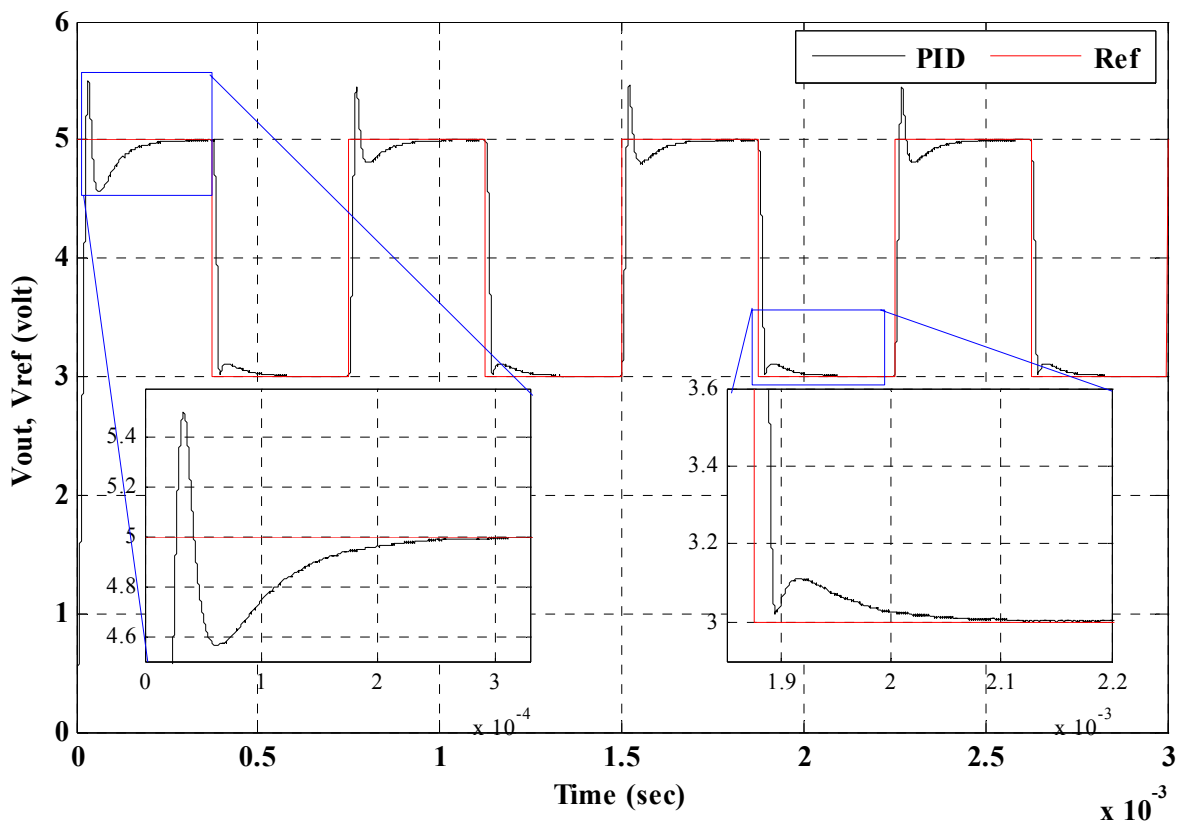

Fig. 19. Output Voltage, Command(reference) Voltage of PID.

8. Conclusion

This study presented a new robust on-line training algorithm for AWNN via a case study of buck converters. A review of AWNN is described and its advantages of simple design and fast convergence over conventional controlling techniques e.g. PID were described. Even though that PID may lead to a better controller, it takes a very long and complicated procedure to find the best parameters for a known system. However on cases with some or no prior information, it is practically hard to create a controller. On the other hand these PID controllers are not robust if the system changes. AWNN can handle controlling of systems without any prior information by learning it through time. For the case study of buck converters, the modeling and the consequent principal theorems were extracted. Afterwards, the Lyapunov stability analysis of the under controlled system were defined in a way to be robust against noise and system changes. Finally, the numerical simulations, in different variable conditions, were implemented and the results were extracted. In comparison with prior controllers which are designed for stabilizing output voltage of buck converters (e.g. PID and NNPC), this method is very easy to implement and also cheap to build while convergence is very fast.

9. Acknowledgements

The authors would like to thank the Austrian Academy of Sciences for the support of this study.

10. References

- Alvarez-Ramirez, J., Cervantes, I., Espinosa-Perez, G., Maya, P., & Morales, A. (2001). A stable design of PI control for DC-DC converters with an RHS zero. *IEEE Transactions on Circuits and Systems I: Fundamental Theory and Applications*, 48(1), 103-106.
- Ang, K. H., Chong, G. C., & Li, Y. (2005). PID control system analysis, design, and technology. *IEEE Transactions on Control Systems Technology*, 13(4), 559-576.
- Bouzari, H., Moradi, H., & Bouzari, E. (2008). Adaptive Neuro-Wavelet System for the Robust Control of Switching Power Supplies. *INMIC* (pp. 1-6). Karachi: IEEE.
- Chen, C., & Hsiao, C.-H. (1999). Wavelet approach to optimising dynamic systems. *IEE Proceedings - Control Theory and Applications*, 149(2), 213-219.
- Gu, D. W., Petkov, P. H., & Konstantinov, M. M. (2005). *Robust Control Design with MATLAB*. London: Springer.
- Ho, D. C., Ping-Au, Z., & Jinhua, X. (2001). Fuzzy wavelet networks for function learning. *IEEE Transactions on Fuzzy Systems*, 9(1), 200-211.
- Hsieh, F.-H., Yen, N.-Z., & Juang, Y.-T. (2005). Optimal controller of a buck DC-DC converter using the uncertain load as stochastic noise. *IEEE Transactions on Circuits and Systems II: Express Briefs*, 52(2), 77-81.
- Lim, K. H., Seng, K. P., Ang, Siew W, L.-M., & Chin, S. W. (2009). Lyapunov Theory-Based Multilayered Neural Network. *IEEE Transactions on Circuits and Systems II: Express Briefs*, 56(4), 305-309.
- Lin, C. M., Hung, K. N., & Hsu, C. F. (2007, Jan.). Adaptive Neuro-Wavelet Control for Switching Power Supplies. *IEEE Trans. Power Electronics*, 22(1), 87-95.

- Lin, F. (2007). *Robust Control Design: An Optimal Control Approach*. John Wiley & Sons.
- Mayosky, M., & Cancelo, I. (1999). Direct adaptive control of wind energy conversion systems using Gaussian networks. *IEEE Transactions on Neural Networks*, 10(4), 898-906.
- Pressman, A., Billings, K., & Morey, T. (2009). *Switching Power Supply Design* (3rd ed.). McGraw-Hill Professional.
- Sarangapani, J. (2006). *Neural Network Control of Nonlinear Discrete-Time Systems* (1 ed.). Boca Raton, FL: CRC Press.
- Slotine, J.-J., & Li, W. (1991). *Applied Nonlinear Control*. Prentice Hall.
- Vidal-Idiarte, E., Martinez-Salamero, L., Guinjoan, F., Calvente, J., & Gomariz, S. (2004). Sliding and fuzzy control of a boost converter using an 8-bit microcontroller. *IEE Proceedings - Electric Power Applications*, 151(1), 5-11.
- Zhang, Q. (1997). Using wavelet network in nonparametric estimation. *IEEE Transactions on Neural Networks*, 8(2), 227-236.
- Ziqian, L., Shih, S., & Qunjing, W. (2009). Global Robust Stabilizing Control for a Dynamic Neural Network System. *IEEE Transactions on Systems, Man and Cybernetics, Part A: Systems and Humans*, 39(2), 426-436.

IntechOpen



Recent Advances in Robust Control - Novel Approaches and Design Methods

Edited by Dr. Andreas Mueller

ISBN 978-953-307-339-2

Hard cover, 462 pages

Publisher InTech

Published online 07, November, 2011

Published in print edition November, 2011

Robust control has been a topic of active research in the last three decades culminating in H_2/H_∞ and μ design methods followed by research on parametric robustness, initially motivated by Kharitonov's theorem, the extension to non-linear time delay systems, and other more recent methods. The two volumes of Recent Advances in Robust Control give a selective overview of recent theoretical developments and present selected application examples. The volumes comprise 39 contributions covering various theoretical aspects as well as different application areas. The first volume covers selected problems in the theory of robust control and its application to robotic and electromechanical systems. The second volume is dedicated to special topics in robust control and problem specific solutions. Recent Advances in Robust Control will be a valuable reference for those interested in the recent theoretical advances and for researchers working in the broad field of robotics and mechatronics.

How to reference

In order to correctly reference this scholarly work, feel free to copy and paste the following:

Hamed Bouzari, Miloš Šramek, Gabriel Mistelbauer and Ehsan Bouzari (2011). Robust Adaptive Wavelet Neural Network Control of Buck Converters, Recent Advances in Robust Control - Novel Approaches and Design Methods, Dr. Andreas Mueller (Ed.), ISBN: 978-953-307-339-2, InTech, Available from: <http://www.intechopen.com/books/recent-advances-in-robust-control-novel-approaches-and-design-methods/robust-adaptive-wavelet-neural-network-control-of-buck-converters>

INTECH
open science | open minds

InTech Europe

University Campus STeP Ri
Slavka Krautzeka 83/A
51000 Rijeka, Croatia
Phone: +385 (51) 770 447
Fax: +385 (51) 686 166
www.intechopen.com

InTech China

Unit 405, Office Block, Hotel Equatorial Shanghai
No.65, Yan An Road (West), Shanghai, 200040, China
中国上海市延安西路65号上海国际贵都大饭店办公楼405单元
Phone: +86-21-62489820
Fax: +86-21-62489821

© 2011 The Author(s). Licensee IntechOpen. This is an open access article distributed under the terms of the [Creative Commons Attribution 3.0 License](#), which permits unrestricted use, distribution, and reproduction in any medium, provided the original work is properly cited.

IntechOpen

IntechOpen