

# We are IntechOpen, the world's leading publisher of Open Access books Built by scientists, for scientists

7,000

Open access books available

187,000

International authors and editors

205M

Downloads

Our authors are among the

154

Countries delivered to

TOP 1%

most cited scientists

12.2%

Contributors from top 500 universities



WEB OF SCIENCE™

Selection of our books indexed in the Book Citation Index  
in Web of Science™ Core Collection (BKCI)

Interested in publishing with us?  
Contact [book.department@intechopen.com](mailto:book.department@intechopen.com)

Numbers displayed above are based on latest data collected.  
For more information visit [www.intechopen.com](http://www.intechopen.com)



# Holography Based on the Weigert's Effect

Zurab V. Wardosanidze

*Institute of Cybernetics of the Georgian Technical University  
Georgia*

## 1. Introduction

Despite the numerous scientific and technological achievements in the field of holography, its main task still remains the registration and the reconstruction of the complete information of the wave scattered by the object.

The wave of the light, scattered by an object, is characterized by four main parameters: Intensity, Phase, Wavelength and Polarization. The primary task of holography is solved, if all four parameters are recorded and reproduced adequately.

The problem of holographic recording and reconstruction of the first three parameters was practically solved by using ordinary light-sensitive materials, which respond only to the Intensity of light (Gabor, 1948; Leith & Upatnieks, 1962; Denisiuk, 1974). As to the fourth parameter - the polarization the problem of its adequate recording and reconstruction was not solved. It is natural that, in the case of the usual photosensitive material, all the characteristics of the wave, except polarization, are displayed as the distribution of isotropic optical properties. However, in the general case of holographic recording the light wave, scattered on the object, changes the polarization. Therefore the total interference pattern will have the modulation also with the polarization, the information about of which is lost during the holographic recording in the ordinary photographic materials.

It should be noted that from the four basic parameters of the light the polarization can be regarded as the most complex. Particularly, to assess the polarization of the light, the measurement of four values is needed (so called Stokes parameters,  $S_0$ ;  $S_1$ ;  $S_2$ ;  $S_3$ ) (Born & Wolf, 1974). However, it turned out that the question of the polarization is more difficult for the unpolarized light. For example, the light remains unpolarized during the passing of anisotropic and gyrotropic objects, but its statistical structure is altered, which radically changes the result of interference. The interference of unpolarized waves gives a usual pattern of light and dark bands, which are also unpolarized. But, if on the path of one of the interfering waves we put an anisotropic half-wave or gyrotropic half-wave (rotator at  $90^\circ$ ) phase plate, the interference pattern disappears and the field becomes evenly lighted. However, the polarization analysis shows, the interference pattern is polarized in this case (Langsdorf & Du Bridge, 1931; Vavilov, 1932). Therefore, the unpolarized light has a certain polarization parameter which can be detected and, accordingly, can be recorded in appropriate conditions.

Thus, the problem of the holographic registration and the reconstruction of the polarization state of the wave can be considered as the most difficult problem in the holography. For registration of the polarization characteristics of light a photosensitive material, which

responds to the polarization is necessary. Such materials are known for a long time, and the phenomenon of creation of the anisotropy in the photosensitive material under the influence of the linearly polarized light is called as Weigert's effect (Weigert, 1919). Later similar effect was observed in a variety of photosensitive materials, including the azo-dyes (Kondo, 1932). The Weigert's effect is a particular case of the sensitivity to the polarization, because in addition to the linear polarization the elliptical and circular polarizations exist as well. About the gyrotropic response of the Halide-silver materials under the influence of circularly polarized light was reported in 1928 (Zocher&Coper, 1928). However, since that time, the gyrotropic response of the photosensitive materials was not confirmed unambiguously.

Holographic recording and reconstruction, on the basis of Weigert's effect, for the first time was implemented in the particular cases of the orthogonal linear and circular polarizations of the reference and object waves (Kakichashvili, 1972;). Weigert's effect has played an important role in the development of holography. Having no analogies holographic diffractive optical elements of the anisotropic structure with complex properties were created. Holographic recording and reconstruction were implemented in the particular cases of linear, circular, partially polarized and unpolarized light. The Weigert's effect has stimulated the search of new photosensitive materials and on the other hand, expanded the range of the studies of holographic processes.

## 2. Weigert's effect in azo-dye materials

From the point of view of Weigert's effect the azo-dyes can be considered as the most interesting materials because of their photosensitivity, reversibility and high value of photo anisotropy (Kondo, 1932). The Azo-dyes are the organic compounds containing one or more group of double chemical bonds of nitrogen, the so called  $-N=N-$  chromophore.

In general, the azobenzene molecule is the basic kernel of the azo-dyes. Besides, it is known that azo-dyes undergo E/Z photo isomerization around  $-N=N-$ , the classical example of which is Azobenzene (Eltsov, 1982)

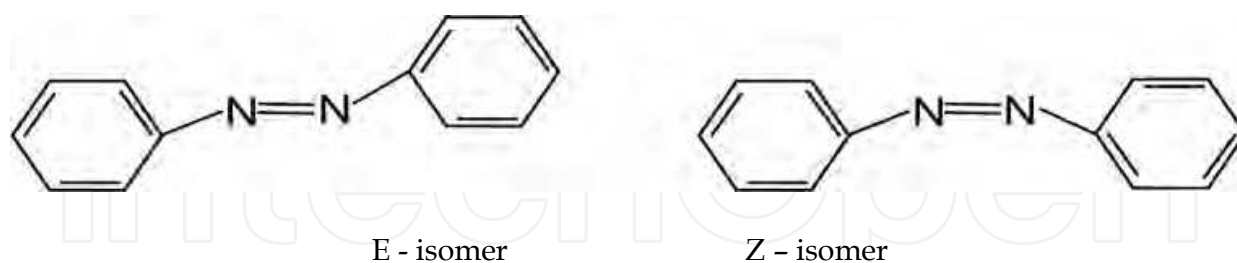

Analogous transformation will have more complex nature for the azo-dyes containing more than one  $-N=N-$  chromophore and different radicals. Currently it is accepted, that the basic factor of Weigert's effect is photo E/Z isomerization in azo-dye materials. But, it is proved, that E/Z isomerization is not necessary and sufficient requirement process for the initiation of Weigert's effect in the azo-dye materials and its mechanisms may be different.

Some authors attempted to explain Weigert's effect in the azo-dye materials, but they were not confirmed uniquely (Shatalin, 1989; Ebralidze, 2002).

The Azo-dyes are the most promising photosensitive materials with the Weigert's effect.

The known photosensitive materials have the following principal disadvantages:

1. The effect of two or more different physical factors is necessary for the realization of the multiple recording and the deletion processes;
2. The spontaneous relaxation takes place;
3. Fatigue of the material during the multiple recording and deleting processes.

From this point of view azo-dye materials with Weigert's effect have obvious advantages:

1. Possibility of multiple recording and deletion with the same actinic light with different polarization;
2. The fatigue of the azo-dye materials is not observed;
3. The dark relaxation practically does not take place after the discontinuation of the impact of actinic light and the generated anisotropy maintains stability in the wide range of temperatures for a long time.

### 2.1 One more possible mechanism of the Weigert's effect in azo-dye colored materials

Three azo-dyes with symmetric structures were chosen for the investigation: Azobenzene, Fernandes, and Mordant Pure Yellow

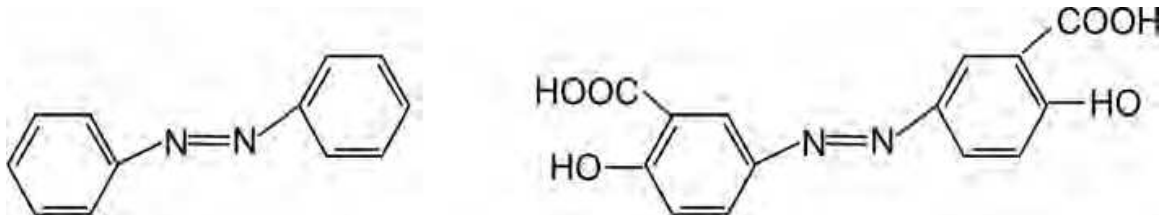

Azobenzene

Fernandes

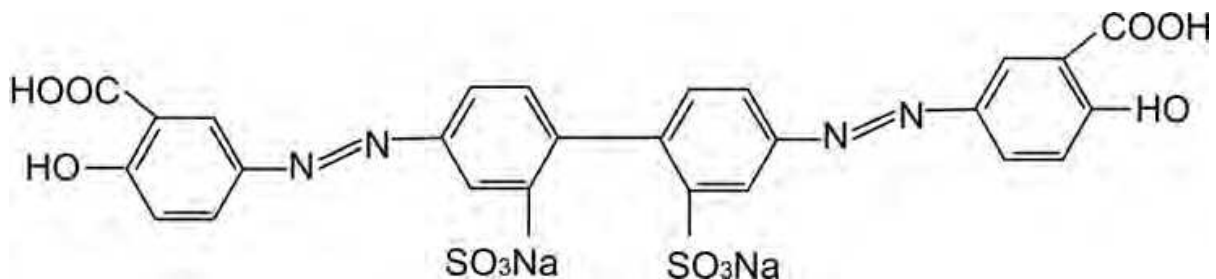

Mordant Pure Yellow

Linear polarized radiation of He-Cd laser ( $\lambda = 441,6 \text{ nm}$ ) was used as an actinic light. The birefringence and the dichroism induced by the linear polarized actinic light can be calculated by means of formulae (Kakichashvili&Shaverdova, 1982):

$$\Delta n\tau \equiv (n\tau)_x - (n\tau)_y = -\frac{1}{2\kappa d} \ln \frac{I_0}{I_{90}} \quad (1)$$

$$\Delta n \equiv (n_x - n_y) = \frac{1}{\kappa d} \arccos \frac{4I_{45} - (I_0 + I_{90})}{2\sqrt{I_0 I_{90}}}$$

where  $\Delta n\tau$  is the anisotropy of absorption,  $\Delta n$  - birefringence,  $k=2\pi/\lambda$ ,  $I_0$ ,  $I_{45}$ ,  $I_{90}$  are the optical transmittance of the exposed samples for the given wavelength when the probe

beam is polarized at  $0^\circ$ ,  $45^\circ$ ,  $90^\circ$  relative to the electric vector of the linearly polarized actinic light.

Fig. 1 shows spectral transmittance characteristics of azobenzene doped in nonpolar matrix of polystirol and in polimethylmetacrilat, before and after the exposure (curves I, II).

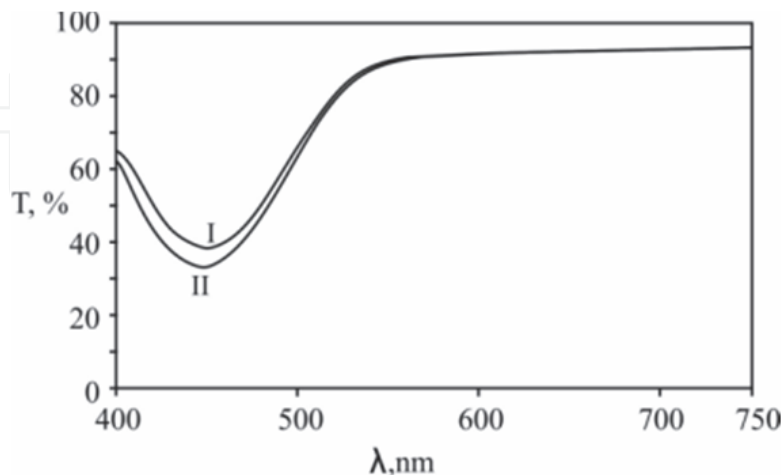

Fig. 1. Spectral transmittance characteristics of azobenzene

The increase of the absorption in the wave range of 400 - 560 nm as a result of the influence of the actinic light confirms E/Z isomerization, the sole possible photo-process in this instance. Weigert's effect does not take place in the given case. Consequently, the E/Z photoisomerisation is not sufficient condition for it's emergence. The water-soluble Azo-dyes Fernandes and Mordant Pure Yellow were introduced into gelatin. Fig. 2 shows spectral transmittance characteristics of azo-dye Mordant Pure Yellow before (curve I) and after (curves II,III,IV) exposure to linearly polarized actinic light ( $\lambda = 441,6$  nm).

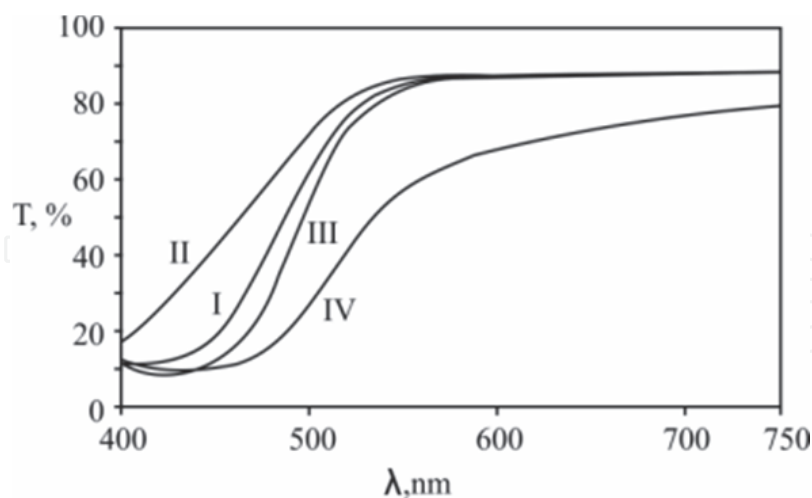
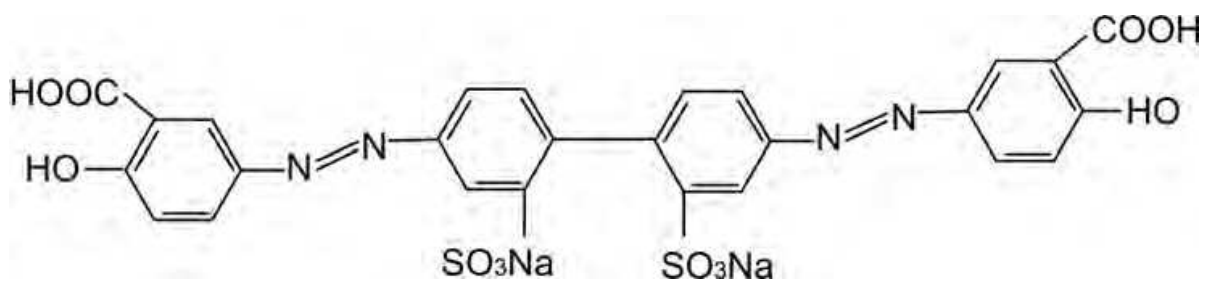

Fig. 2. Polarization spectral transmittance characteristics of azo-dye Mordant Pure Yellow

Curve (II) corresponds to the spectrum of transmittance of the irradiated sample, when the polarization of sensing light coincides with the polarization the actinic light. Curve (III) corresponds to the transmittance spectrum of the same sample, for orthogonal polarization of sensing light and curve (IV) corresponds to transmittance spectrum, when the angle is  $45^\circ$ , between the polarizations of actinic and sensing light. As can be seen

from Fig. 3, in contrast to the azobenzene case, Weigert's effect takes place. Analogous results were obtained for monoazo-dye Fernandes. Thus, one of the characteristics of observed Weigert's effect is that the absorption of these materials decreases in the direction of electric vector of actinic light and, on the contrary, increases in orthogonal direction. This fact indicates that the number of absorbing oscillators parallel to polarization of actinic light decreases and the number of absorbing oscillators with the orthogonal directions, increases. However, decrease in the absorption of the material along the direction of actinic light polarization of is greater than its increase in orthogonal direction in the wave range of 400-560 nm. It means that the decrease in the number of absorbing oscillators oriented along the electric vector of actinic light must be greater, than the increase in the number of their orthogonal absorbing analogous oscillators, which is inadmissible. One of the explanations of this phenomenon may be that the initial oscillator and the oscillators, which were obtained after transformation, must be different. Some anomalies of azo-dyes with hydrogen — H and hydroxyl — OH groups in the isomerization process confirms such approach (Eltsov, 1982). Under the influence of actinic light — N = N — chromophore is breaking down and one of its nitrogen atom creates — N - H — auxochrome oscillator with perpendicular direction. In this case the strength of the — N - H — oscillators is much lower than — N = N — oscillator (Eltsov, 1982). As gelatin contains many endings H, OH, NH<sub>2</sub> and some amount of water (HOH), there always can exist analogous transformation of molecules of the azo-dyes.



Initial structure

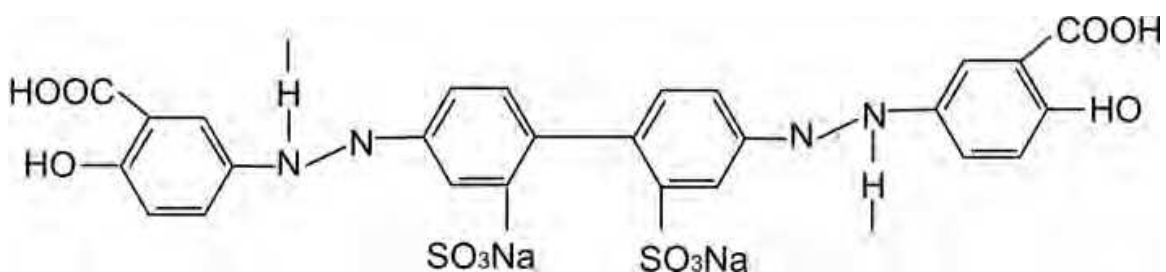

Transformed structure

The dependence of photosensitivity and occurrence of Weigert's effect of azo-dye materials on the humidity is shown in Fig. 3. Curves I and II (Fig. 3, a) correspond to 3% and 15% of emulsion humidity respectively.

Thus, the rate of rising and maximum value of Weigert's effect is greater for more humid emulsion layers, the good illustration of which is Fig. 3 b. The parts with higher brightness correspond to higher humidity and anisotropy under the equal energy of exposure.



The obtained results confirm the possibility of existing of one more possible mechanism of Weigert's effect for azo-dye. Under the influence of linearly polarized actinic light of the initial structure of the molecule of azo-dye transforms to structure, where initial  $-N=N-$  chromophore is changed in two auxochrome  $-N-N-$  and  $-N-H-$ . Therefore, powerful absorption oscillator  $-N=N-$  transforms into two oscillators with weaker absorption. In addition the direction of new  $-N-H-$  oscillator already is orthogonal to direction of initial oscillator  $-N=N-$  (Vasilieva N.V. et al 1978). Thus, the absorption of the given material must decrease along the direction of electric vector of the linearly polarized actinic light and must increase in orthogonal direction. In addition, decrease in absorption along the electric vector of the actinic light must be greater, than increase in absorption in orthogonal direction, because of difference of oscillator's strength mentioned above.

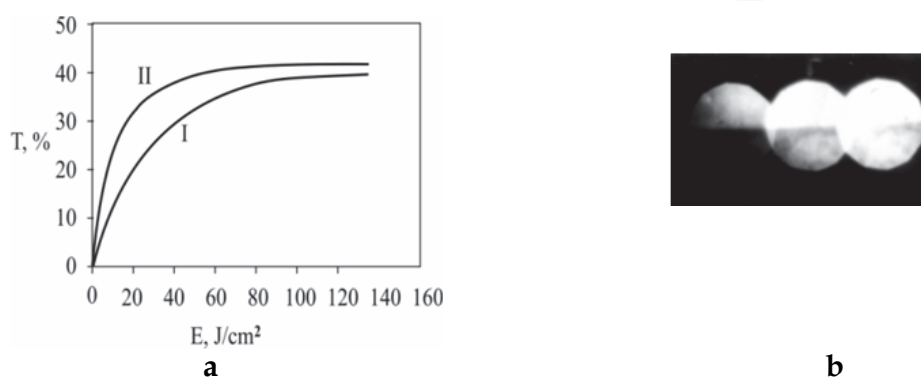

Fig. 3. Humidity dependence of the photosensitivity (a) and of the Weigert's effect (b) of azo-dye.

## 2.2 Reversibility of the Weigert's effect in azo-dye colored materials

The results of investigation of multiple recording and erasure of the Weigert's effect in azo-dye, is in good compliance with the mechanism mentioned above. The scheme of experiment is presented in Fig.4. Linearly polarized light of the He-Cd laser 1 ( $\lambda=441.6$  nm) is falling on the sample at the Brewster's angle ( $\alpha \approx 56^\circ$ ). The can rotate in its own plane. Circularly polarized sensing light of the He-Ne ( $\lambda=632.8$  nm) laser 3 is falling perpendicularly to the sample, passing through polarizer 4. Polarizer 4 is oriented in such way that the angle between linear polarizations of actinic and probing lights on the plane of the sample is  $45^\circ$ . The orientation of the analyzer 5 relative to the polarizer 4 is  $90^\circ$ , so it does not transmit light. Therefore the radiation detector 6 and recorder 7 cannot register the light intensity until the exposure of the investigated sample with the actinic light.

Under the influence of the linearly polarized actinic light the Weigert's effect in azo-dye takes place, and as a result, the linear polarization of the probing wave transforms to an elliptical one. Because of this the analyzer 5 transmits the part of probing light and the recorder registers it. The intensity of this part of the probing wave gives the information of the value of anisotropy (Weigert's effect). Initially, the sample is irradiated up to saturation of Weigert's effect. After this the actinic light is blocked and the sample is rotated by the angle of  $90^\circ$  in its plane. Therefore, the linear polarization of the actinic light becomes orthogonal relative to the axis of induced anisotropy, due to which the deletion of anisotropy starts. After the full deletion of the anisotropy, the impact of actinic light is terminated and the sample returns to its initial state for repetition of the recording process.

The multiple recording and deletion of anisotropy showed that fatigue of the investigated material was not observed. The dynamics of 5 series of recording and deletion of anisotropy is represented in Fig.5.

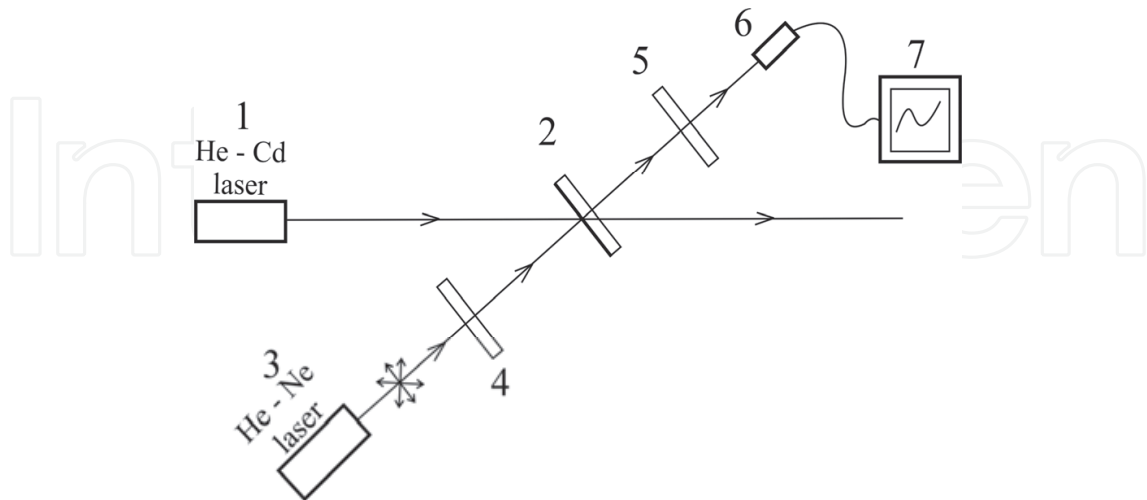

Fig. 4. The scheme of multiple recording and erasure of Weigert's effect

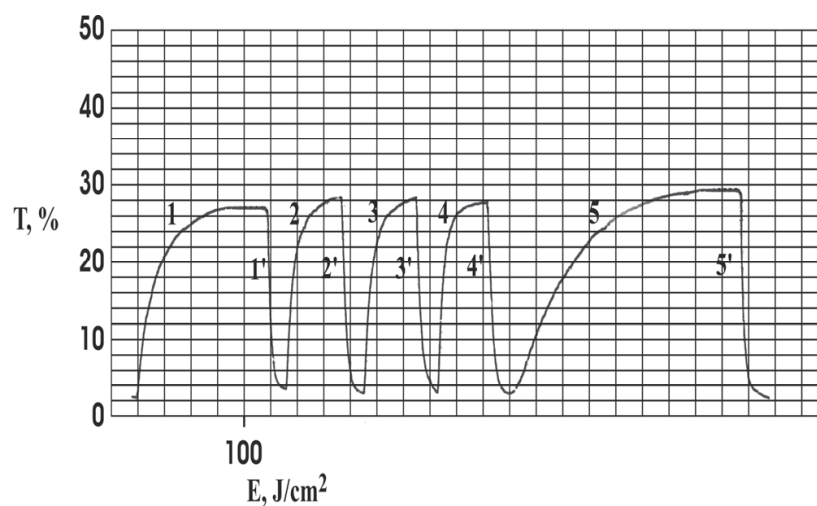

Fig. 5. The dynamics of 5 series of recording and erasure of Weigert's effect

The first four pair of curves 1-1'; 2-2'; 3-3'; 4-4' correspond to the recording and erasure of Weigert's effect, when linear polarization of the actinic light is changing consistently on  $90^\circ$ . As follows from the obtained results, the first process creation of Weigert's effect requires more than five times as much exposure energy, than the first exposure-erasure process (curves 1-1'). In addition, in the subsequent series of recording and deletion (curves 2-2'; 3-3'; 4-4') the recording process requires far less exposure energy, but for the erasure the energy remains the same as in the first case. The final stage the process of recording and deletion of the Weigert's effect is different than first four (curves 5-5'). In this case the sample does not return to its initial state after the end of the fourth stage of deletion (curve 4') and the process of creation of anisotropy continues by the same polarization of the actinic light (curve 5). In this case the saturation of the Weigert's effect needs 1.8 times more exposure energy than in the initial step of recording (curve 1). Nevertheless, as it follows from curve



5', the speed of the deletion of the Weigert's effect remains the same as in the previous cases (curves 1'; 2'; 3'; 4'). Thus, the recording and deletion of Weigert's effect in the azo-dyes have various character. Particularly, the recording process is characterized by saturation, i.e. Weigert's effect achieves the maximum value and maintains its value during the whole time of the recording. In contrary to that, upon the end of anisotropy deletion process, a new recording process by the same polarization of actinic light starts.

Let the azo-dye material represent the ensemble of statistically oriented absorbing oscillators of  $-N = N -$ . For oscillators oriented parallel to the electric vector of actinic light the transformation is maximum and is zero for oscillators oriented at  $90^\circ$ . Let the electric vector of actinic light be parallel to one of the absorbing oscillators in the initial stage of the repeating recording and erasure (Fig. 6 a). Due to of influence of actinic light the oscillator  $-N = N -$  transforms in a new  $-N - H -$  oscillator oriented orthogonally (Fig.6 b). The value of Weigert's effect in this dynamic process achieves its maximum after the full transformation of all oscillators. After the change of the mutual orientation of the sample and the polarization by  $90^\circ$  the electric vector of actinic light becomes parallel to the new  $-N - H -$  oscillator and begins its transformation (Fig. 6 c).

Two opposite processes will take place on this stage: a) formation of new anisotropy, orthogonal to initial one, as a result of second chromophore oscillators  $-N = N -$  transformation and b) deletion of the first anisotropy as a result of reconstruction of chromophore oscillators  $-N = N -$  which were transformed on the first stage (Fig.6 d, c). Thus, the sample reaches the state when the value of the residual anisotropy and the new anisotropy with orthogonal direction become equal to each other and the resulting anisotropy of the sample becomes zero. I.e. material behaves as an isotropic medium, but in reality, here takes place seeming isotropy, when two orthogonal anisotropies compensate each other. Accordingly, to achieve such a neutral state of the material, relatively small energy is needed. After mutual reorientation of the chromophores in the sample and the polarization by  $90^\circ$ , a new phase of anisotropy formation is determined by two opposing processes again: 1. due to reconstruction of the second chromophore  $-N = N -$  in connection with the transformation of their auxochrome oscillators and 2. due to transformation of the first chromophores  $-N = N -$  because of emergence of their auxochrome oscillators. Accordingly, the exposure energy, for the achievement of the maximum value of anisotropy, will be smaller than in the original recording process. Subsequent repetition of these processes recording and erasure, gives similar results (curves 2'; 3-3'; 4-4' in Fig.5). As it follows from Fig.5 the stage 5-5' of described process, is differs from previous stages. The matter is that, in this case, the mutual orientation of the investigated sample and polarization of actinic light has not been changed after the achievement of minimal anisotropy. The difference of this process with respect to previous one, is also the result of two opposite processes. Particularly, formation of new anisotropy, orthogonal to previous one, is continuing because of continuation of destruction of the second chromophore oscillator  $-N = N -$ , which is oriented parallel to electric vector of actinic light. At the same time, deletion of previous anisotropy because of continuation of the reconstruction of destroyed chromophore oscillator  $-N = N -$  which are oriented orthogonally to the electric vector of actinic light (Fig. 6 e) takes place. Consequently, the energy needed for the anisotropy saturation on this stage must be higher than on all previous recording stages (curve 5 of Fig.5). In this case, direction of the final anisotropy is orthogonal to the initial one, obtained at the first stage. Under the next

mutual reorientation of the investigated sample and polarization of actinic light by  $90^\circ$ , the anisotropy deletion process with the same speed as at the previous stages takes place (curves 1'; 2'; 3'; 4'; 5' of Fig. 5). The anisotropy recording and erasure processes here have different natures. Namely, the formation of anisotropy caused only by destruction of oscillators takes place only at the initial stage of the recording (curve 1 in Fig.5). In all the following stages of multiple recording and deletion of anisotropy up to stage 5-5', takes place two processes in opposite directions as it was described above (Fig.6). It is interesting that after the first stage of anisotropy formation, it is impossible to return the molecules of the azo dye (absorbing oscillators) into the initial state (Fig. 6 a) by irradiation with linearly polarized actinic light.

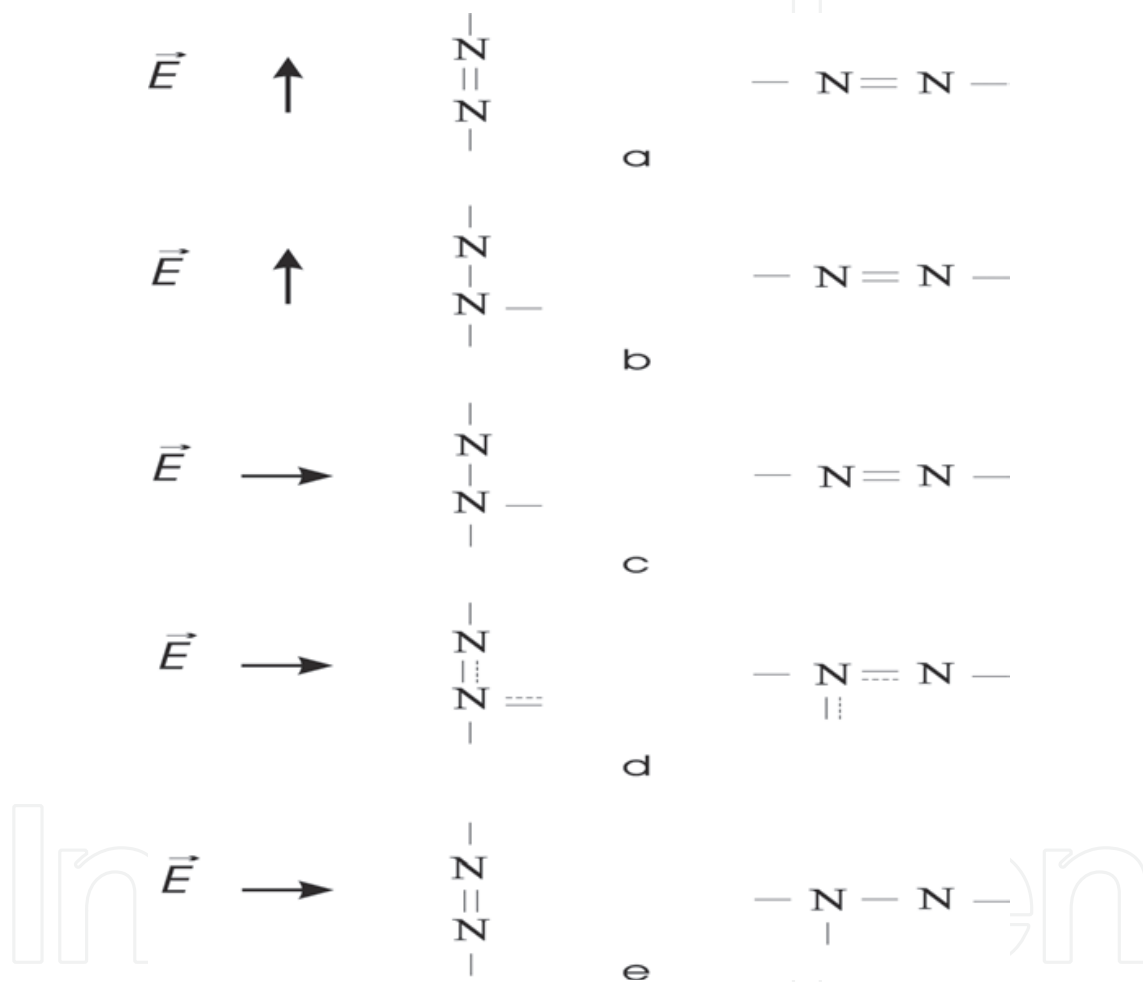

Fig. 6. The scheme of transformation of absorbing oscillators of azo-dye

### 3. Holographic recording in the general case of linear polarization

An interesting result gives the investigation of holographic recording in the azo-dye material with Weigert's effect in the general case of linear polarization of the object waves. For the simple theoretical calculations the Jones vector-matrix method of was used (Jones, 1941; Kakichashvili, 1974).

Photosensitive material H with Weigert's effect perpendicular to axis OZ is placed into a rectangular system of coordinates (Fig. 7).

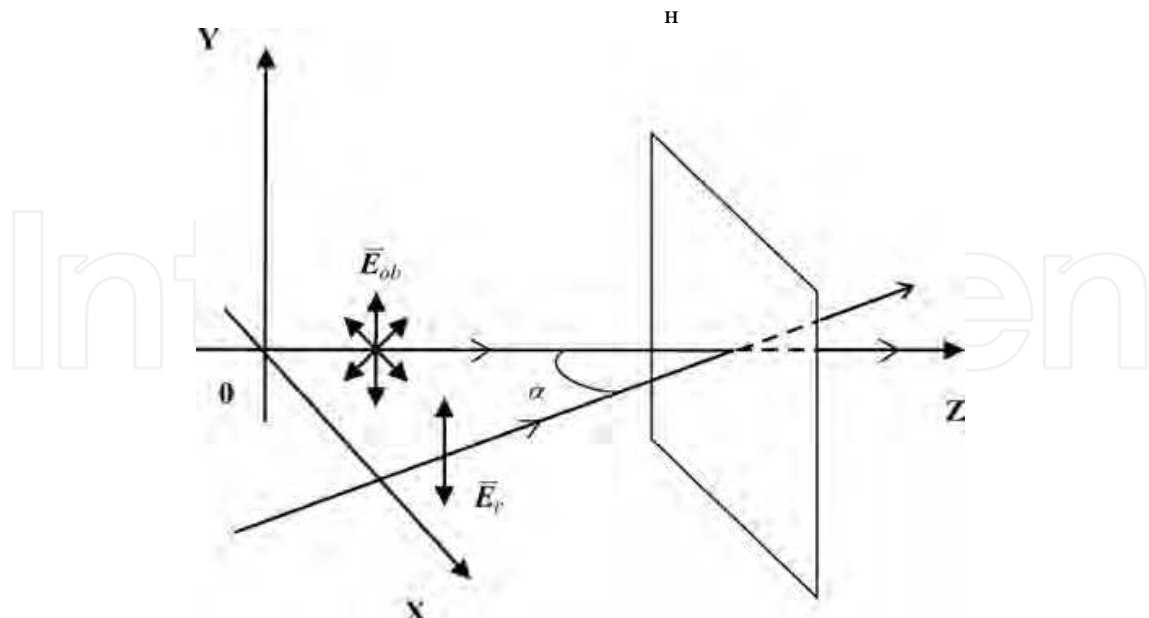

Fig. 7. The scheme of holographic recording

The object wave represents a linearly polarized plane wave of all the possible orientations of linear polarization, which spreads along the OZ axis and falls normally on the surface of the photosensitive medium H

$$\vec{E}_{ob} = \vec{E}_{01} \begin{pmatrix} \cos \theta \\ \pm \sin \theta \end{pmatrix} \exp i(\omega t - kz + \delta) \quad (2)$$

where  $\vec{E}_{01}$  is amplitude,  $\theta$  is the orientation of the electrical field vector in the wave,  $\omega$  is the frequency of the wave,  $k = 2\pi / \lambda$  is the wave number in vacuum,  $\delta$  is the relative phase.

The reference wave represents linearly polarized plane wave, the electric vector of which oscillates parallel to OY axis, it is located in XZ plane and spreads at a small angle with respect to the object wave (Fig. 7)

$$\vec{E}_r = \vec{E}_{02} \begin{pmatrix} 0 \\ 1 \end{pmatrix} \exp i(\omega t - kz \cos \alpha) \quad (3)$$

where  $\vec{E}_{02}$  is the amplitude of the reference wave;  $\alpha$  is the angle of incidence on the plane H. Thus, both the object and reference waves are located in XZ plane and their electric vectors are situated in the plane of the photosensitive medium H.

Let the dependence of the refractive indices of the photosensitive medium on the intensity have linear character (Kakichashvili, 1974):

$$\begin{aligned} \hat{n}_1 &= \hat{n}_0 + aE_1^2 \\ \hat{n}_2 &= \hat{n}_0 + aE_2^2 \end{aligned} \quad (4)$$

After application of the known theory of interference pattern calculation (Born, 1970;) and the theory of polarization holography the reconstructed image of the object wave has the form (Kakichashvili, 1974):

$$\vec{E}_{-1} = M_{-1}\vec{E}_r \approx -2ikda\vec{E}_{01}E_{02}^2 \exp(-ikd\hat{n}_0) \begin{pmatrix} \cos\theta \\ \pm\sin\theta \end{pmatrix} \exp i(\omega t - kz + \delta) \quad (5)$$

This is the imaginary image of the object which preserves both the polarizing character and direction of the object wave. Thus, the theory shows the possibility of the holographic recording and adequate reconstruction of linear polarization in general case on the basis of the Weigert's effect.

### 3.1 Experimental results and discussion

Experimental investigation confirms the theoretical result. The scheme of holographic recording is shown in Fig. 8. The collimated laser beam ( $\lambda = 441,6$  nm), with vertical linear polarization, is divided into two parts with identical intensity by means of a usual glass prism **P** and polarization prism **PP**. The prism **P** deflects half of the beam to overlap with object wave in the plane of photosensitive medium **H** without changing its polarization and creates the plane wave, electric vector of which oscillates along OY axis (Fig.7). The object wave is formed by means of a special polarizing prism **PP** composed of two wedges, one of which represents the optically active crystal of quartz. The second part of the prism represents the wedge of usual glass with analogous geometrical form and the same refractive index. After passing through this prism, the light does not change its spreading direction, but its polarization varies from  $+90^\circ$  to  $-90^\circ$  along the cross-section. The analyzer **A** gives a possibility for polarization analysis both of object **PP** and of its reconstructed image. Fig. 8 **b** shows the distribution of polarization of the reference and object waves along the cross-sections of these waves. Fig. 9 **a** shows the view of the object after passing the analyzer **A** whose orientation changes from  $+90^\circ$  up to  $-90^\circ$ . Fig. 9 **b** shows the reconstructed image of the object at the same orientations of analyzer, by which the hologram reconstructs the polarization of the object wave with sufficient precision. Fig. 9 **c,d,e** represents the result of holographic recording of the test-object composed of accidentally oriented polarizers.

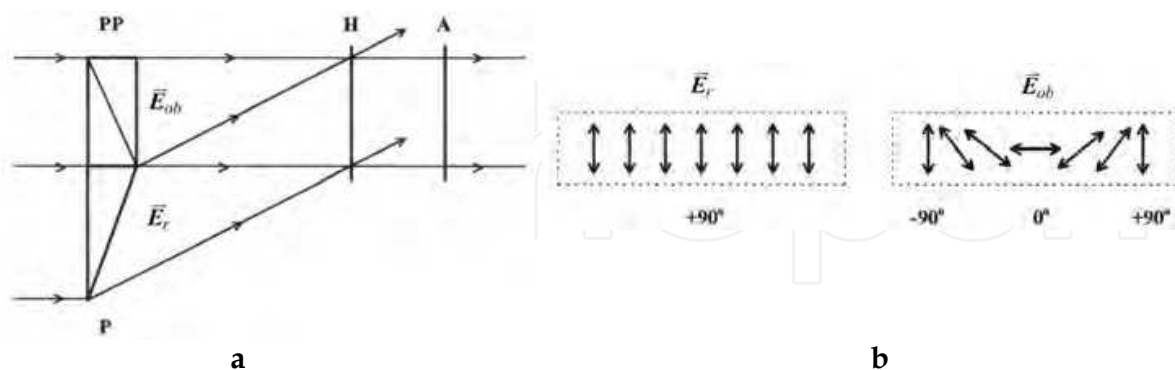

Fig. 8. The experimental scheme of holographic recording **a** and projection pictures of reference and object waves **b**

Fig.9 **c** is a view of the test-object without analyzer, Fig. 9 **d** is the same image through analyzer and Fig.9 **e** is the reconstructed image of the object after the analyzer.

In accordance with Fig. 9 the polarization of the reconstructed images doesn't differ considerably from the polarization of the object wave. Little difference may be the result of

the nonlinearity of recording, which was not taken into account in the theoretical calculations. On the other hand it was found that with increasing initial absorption of the photosensitive medium, the proportion of the dichroism of Weigert's effect is much greater and polarization of the reconstructed image is closer to the polarization of the object image. However, the intensity of the reconstructed image decreases strongly in this case, and the conditions of its observation sharply deteriorate.

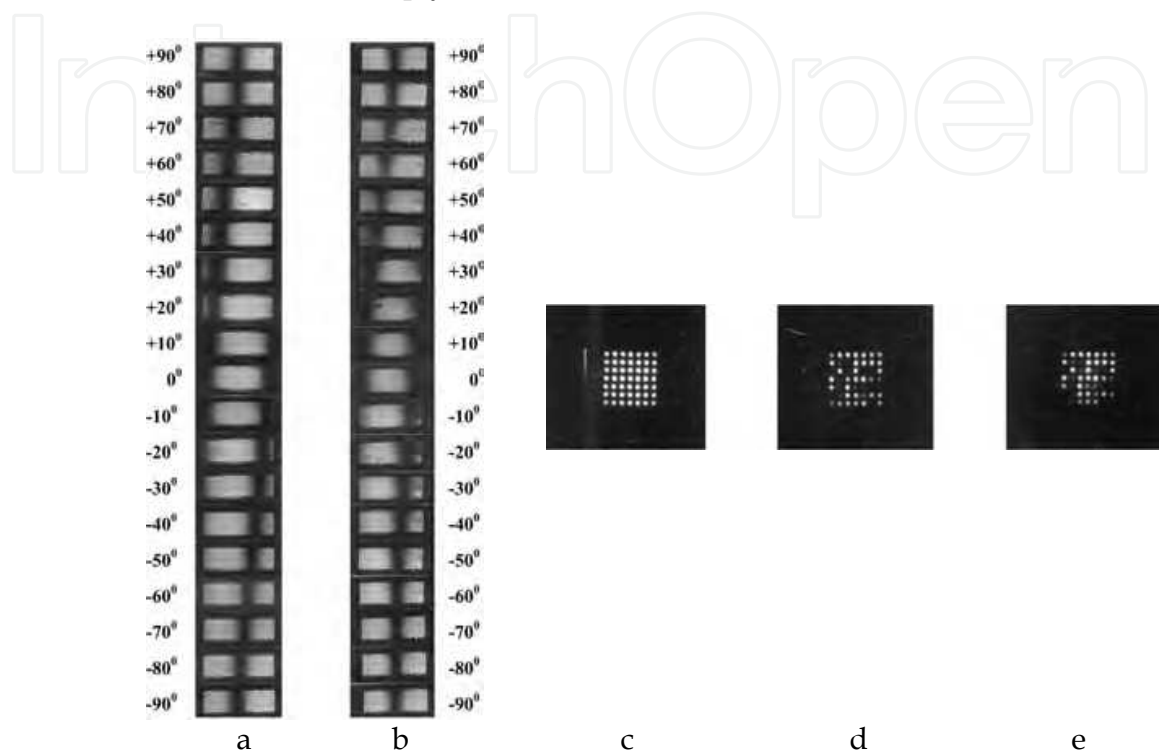

Fig. 9. The views of the objects and their reconstructed images

Thus, it is possible to formulate the following conditions, which are necessary for holographic recording and adequate reconstruction in the general case of linear polarization:

1. Selection of the light-sensitive material's, for example azo-dyes, with a wide range of linear recording.
2. Selection of the optimal absorption of the azo-dye with Weigert's effect.

#### 4. Diffractive optical elements of an anisotropic structure

Application of the Weigert's effect gives interesting results for creation of holographic diffractive optical elements. Particularly, as it is known, the standard holographic diffractive optical elements (diffraction gratings, zone plates, raster systems, holographic mirrors) have isotropic structure. Because of this, they don't influence the polarization state and they have a possibility of transformation and separation only of phase, amplitude and spectrum of the light. In addition, their maximum diffraction efficiency could not be more than 33% for the thin holograms. In contrast, the holographic diffractive optical elements based on the Weigert's effect possess anisotropic structure and have opportunity to influence the state of polarization of light. Diffraction efficiency of these optical elements reaches 100%. For example, the diffractive gratings with efficiency 100% have been already obtained (Shatalin&Kakichashvili, 1987). From this point of view, the most interesting holographic



diffraction optical elements represent zone plates (Fresnel lenses) and raster systems of an anisotropic structure.

#### 4.1 Zone plates and raster systems on the basis of Weigert's effect

For creation of the Zone plates (Fresnel lenses) and raster systems the axial holographic recording scheme was used (Fig. 10). The circularly polarized plane wave of actinic light ( $\lambda=441,6$  nm) is divided by means of calcite lens 1 in two spherical waves with orthogonal linear polarizations and identical intensity. Calcite lens was cut parallel to the optical axis, which allowed the formation of two spherical waves, of different divergence, propagating coaxially. Quarter-wave phase plate 2 converts the linearly orthogonally polarized waves into the circularly orthogonal polarized ones. The converging lens 3 is providing overlapping of separated waves in one area in the plane of the photosensitive material 4. Thus, in the plane of the photosensitive material an interference pattern with the radial distribution of linear polarization is formed. As a photosensitive material the azo-dye colored gelatin was used. Diffractive efficiency of the obtained zone plates reached 80%. Fig. 11 shows the photograph of the zone plate in the polarization microscope for its orientations at an angles  $0^\circ$ ,  $45^\circ$  and  $90^\circ$  with respect to the crossed polarizers.

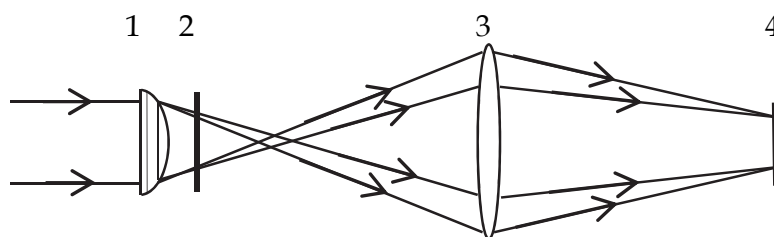

Fig. 10. The scheme of holographic recording of the zone plate

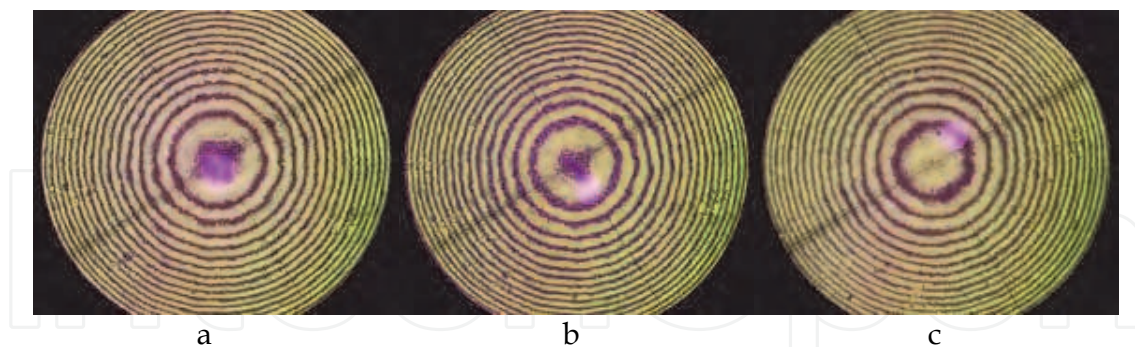

Fig. 11. The image of the zone plate in the polarization microscope

The diffraction from the obtained zone plate is presented in Fig. 12. Fig. 12 **a** corresponds to a zone plate illuminated with a linearly polarized wave. Fig. 12 **b** shows a zone plate illuminated with a circular polarized wave. As it follows from Fig.12 the zone plate behaves as the diverging lens in the first case and as a collecting lens in the second case. For the left circular polarization of the incident wave, this zone plate behaves as a collecting lens and for the right circular polarization it behaves as a diverging lens. Fig. 13 shows the image of the anisotropic complex object obtained with such lenses. The object was illuminated with left- (a) and right- (b) circularly polarized light. As it can be seen from



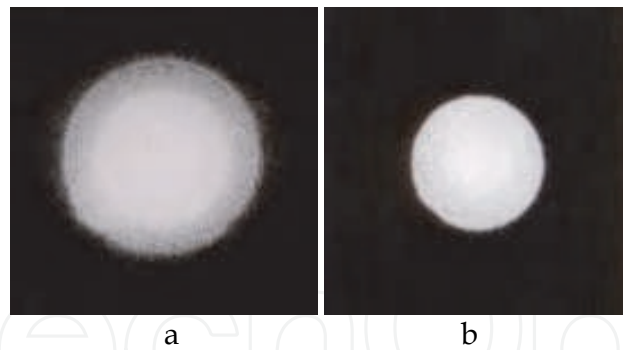

Fig. 12. Diffraction of the linearly polarized (a) and circularly polarized (b) light on the zone plate

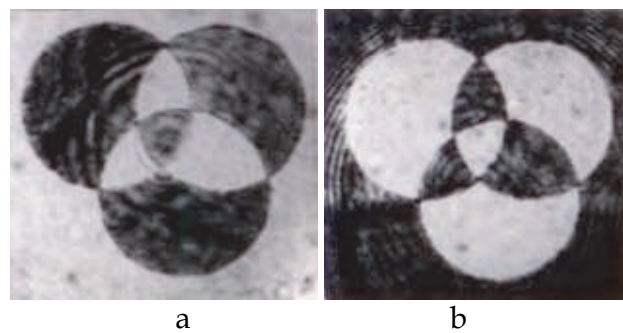

Fig. 13. The image of the anisotropic complex object obtained by means of zone plate.

Fig. 13 these images are complementary. So, the zone plate created with of orthogonal circular polarizations of recording waves automatically performs the subtraction, which is important for solving some problems of microlithography and optical information processing.

Similar technology is used to create raster systems. In this case the mosaic of the holographic microlenses with an anisotropic structure is arranged. Fig.14 shows the image of such raster placed between crossed polarizers and the diffraction pictures on this raster. Fig. 14 a is the image of the raster between crossed polarizers. Fig. 14 b shows the diffraction of the expanded collimated beam He-Ne laser ( $\lambda= 632.8 \text{ nm}$ ) on this raster and Fig. 14 c shows the diffraction of the unexpanded beam on one of the microlense of the raster.

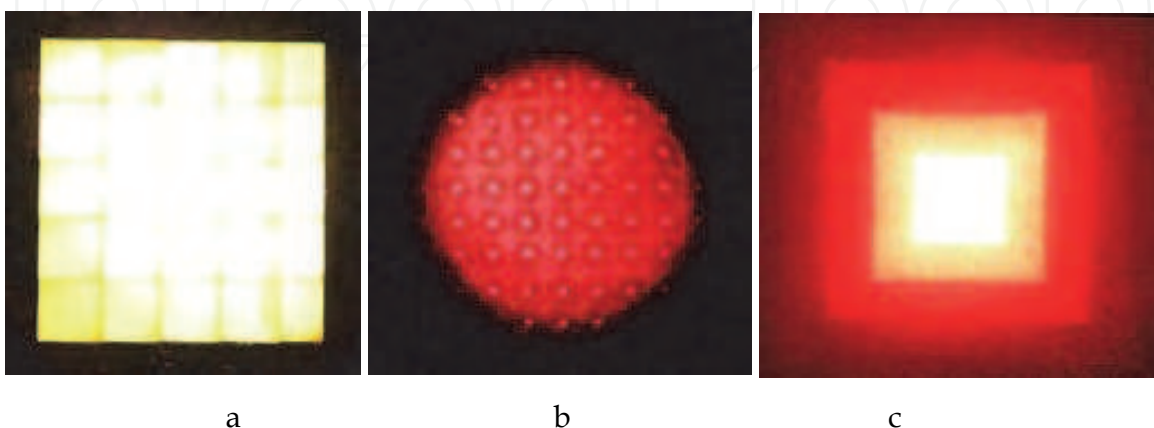

Fig. 14. The raster's image (a) and the diffraction pictures on them (b,c)

#### 4.2 Holographic chiral structure on the basis of Weigert's effect

It is known that the method of N - Jones matrices is used to describe the evolution of the polarization state of polarized light as it propagates through the anisotropic optical device consisting of a sequence of anisotropic phase plates, the optical axes are rotated through a certain angle relative to each other (Jones, 1948). Similar systems have been made long ago, in the form of spiral structures. They proved that by the passage of linearly polarized light through the mentioned system, rotation of the polarization plane takes place, analogically to the optical rotator (Dawson&Young, 1960). However, the case when the wavelength of the light is comparable with the period of the spiral structure was not considered in these studies. The physical pictures of the phenomenon, in these extreme cases, are substantially different. As examples the liquid crystals or the sculptured thin films with the chiral structures can be cited (Chilaya et.al., 1997; Laktakia&Messier, 2005). In particular, in these cases, in addition to optical rotation, the selective reflection at wavelengths which are comparable to the period of such structures takes place. It is obvious that there exists a possibility of the realization of similar chiral structures with the help of holographic method based on the Weigert's effect.

A simple theoretical analysis confirmed this assumption. Consider the formation of the interference pattern of two orthogonally circularly polarized plane light waves of equal intensity propagating in opposite directions (counter-propagating beams) (Fig. 15). Let the electric vectors of interfering waves be (Jones, 1941; Kakichashvili, 1974):

$$\vec{E}_+ = \vec{E}_0 \begin{pmatrix} 1 \\ i \end{pmatrix} \exp(i\omega t - kx + \delta_1) \quad (6)$$

$$\vec{E}_- = \vec{E}_0 \begin{pmatrix} 1 \\ -i \end{pmatrix} \exp(i\omega t + kx + \delta_2) \quad (7)$$

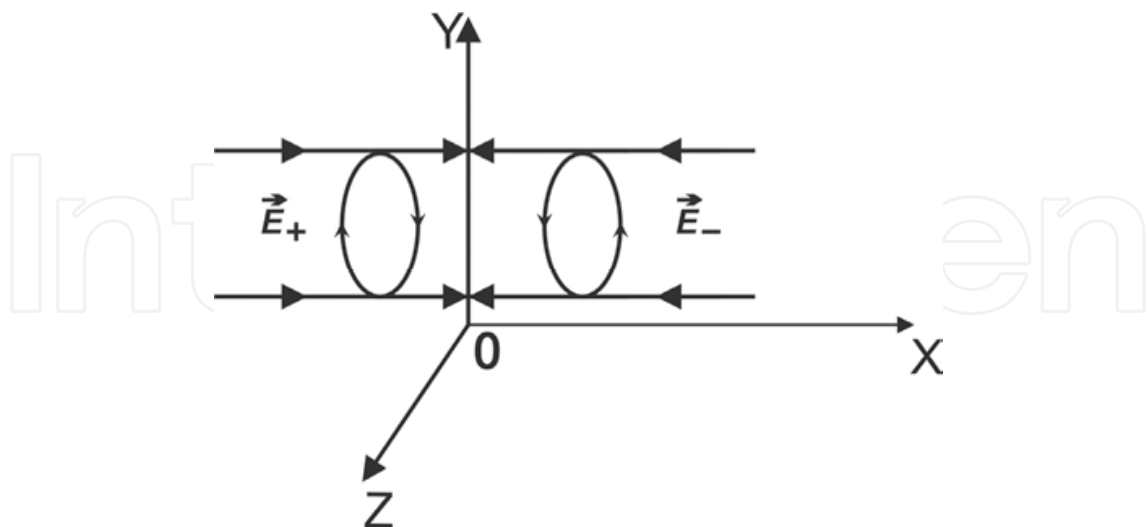

Fig. 15. Circularly orthogonally polarized counter-propagating beams

where  $\vec{E}_0$  is the amplitude,  $\omega$  is the frequency,  $k=2\pi/\lambda$  is the wave number,  $\lambda$  is the wavelength,  $x$  is the direction of propagation,  $\delta_1, \delta_2$  are initial phases. After analogous to that in Chapter 3, for the interference pattern of these waves, we will have:

$$\vec{E}_\Sigma = 2 \begin{pmatrix} \sin[2kx + (\delta_2 - \delta_1)] \\ \cos[2kx + (\delta_2 - \delta_1)] \end{pmatrix} \quad (8)$$

Thus, from (8) follows that the total interference pattern is polarized linearly and its electric field vector describes a helix along the axis OX. Fig. 16 shows the distribution of the vector of electric field in the standing wave in this case.

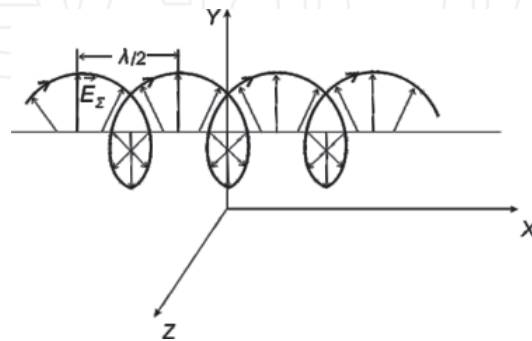

Fig. 16. Vector standing wave with helical structure

Clearly, if such a wave is created in a photosensitive material with the Weigert's effect, the obtained picture of the anisotropy will have a chiral structure, similar to the cholesteric liquid crystal.

If the dependence of the refractive indices of the photosensitive medium on the intensity has linear nature (Kakichashvili, 1974):

$$\begin{aligned} \hat{n}_1 &= \hat{n}_0 + aE_1^2 \\ \hat{n}_2 &= \hat{n}_0 + aE_2^2 \end{aligned} \quad (9)$$

For the matrix of this holographic diffractive optical element, created in this case, we will have (Jones, 1941; Kakichashvili, 1974):

$$M_d = 2ikda \exp(-ikd\hat{n}_0) \begin{pmatrix} \cos[2kx + (\delta_2 - \delta_1)] & \sin[2kx + (\delta_2 - \delta_1)] \\ \sin[2kx + (\delta_1 - \delta_2)] & -\cos[2kx + (\delta_2 - \delta_1)] \end{pmatrix} \quad (10)$$

The diffracted wave produced from such structure is:

$$\begin{aligned} \vec{E}_d &= M_d \vec{E}_+ = 2ikda E_0 \exp(-ikd\hat{n}_0) \begin{pmatrix} \cos[2kx + (\delta_2 - \delta_1)] & \sin[2kx + (\delta_2 - \delta_1)] \\ \sin[2kx + (\delta_2 - \delta_1)] & -\cos[2kx + (\delta_2 - \delta_1)] \end{pmatrix} \begin{pmatrix} 1 \\ i \end{pmatrix} \times \\ &\times \exp i[\omega t - kx + \delta_1] = 2ikda E_0 \begin{pmatrix} 1 \\ -i \end{pmatrix} \exp i[\omega t + kx + (\delta_2 - kd\hat{n}_0)] \end{aligned} \quad (11)$$

The expression of  $\vec{E}_d$  represents the second wave (8) diffracted on the obtained chiral structure. From (11) follows that similar holographic structure behaves like a cholesteric liquid crystal.

The results of analyze were confirmed experimentally by means of holographic recording in counterpropagating beams, two orthogonal circularly polarized waves. The optical scheme of experimental equipment is presented in Fig. 17. Circularly polarized beam of He-Cd-laser ( $\lambda= 441.6$  nm), divides into two mutually perpendicular linearly polarized beams of equal intensity, with the help of birefringent crystal of the calcite **1**. Crystal was cut in directions parallel to the main crystallographic planes, so that the incident beams splits into two parallel to each other ones, the electric vectors of which oscillate at an angle of  $\pm 45^\circ$  with respect to the drawing plane. The collimator **2 - 3** creates two parallel collimated beams, which are falling into two total internal reflection prisms **4** and **4'**. Between the prisms **4** and **4'** is placed a photosensitive material **5**, for instance, a glass plate, covered with a layer of azo dye embedded in gelatin with a strong Weigert's effect. The  $\lambda/4$ - phase plate **6** ensures the formation of two opposing waves with the orthogonal circular polarizations propagating in the photosensitive layer. To minimize the influence of Fresnel reflection on the recording process, the space between the prisms **4,4'** was filled with immersion liquid, into which the photosensitive material **5** is placed. In addition the photosensitive material was tilted at a small angle to separate the diffracted light from the Fresnel component. Obtained holographic structure, with the distributed anisotropy, represents the selective mirror, with sufficiently low reflection efficiency ( $\eta=1,4\%$ ). The dependence of the reflection (diffraction efficiency) on the polarization state, for the same wavelength used for recording ( $\lambda=441,6$  nm), was investigated. The use of the same wavelength for reading is due to the fact that the step of obtained anisotropic holographic structure is determined by the wavelength of recording and corresponds exactly to it. For other wavelengths the diffraction is absent. Fig.18 illustrates the dependence of diffractive efficiency of the obtained holographic structure on ellipticity of the polarization of the incident wave. As it follows from Fig. 18, at the right circular polarization of the probe light, when the ellipticity is  $\varepsilon=1$ , the reflection efficiency has the maximal value ( $\eta=1,4\%$ ). With decreasing the ellipticity to 0, i.e. for linear polarization of the sensing light, the reflection efficiency decreases proportionally to 0,8%. Upon of the change of rotation of the electric vector of the incident wave in opposite proportional decrease in the efficiency of reflection, takes place and goes to zero for the left circular polarization. It is important, that the reflected light remains left-circularly polarized, in all cases. All of these facts confirm that the distribution of the anisotropy, in the obtained holographic structure, has chiral nature. A low reflection efficiency is the result of a high absorption (about 90%) in the photosensitive medium for the wave  $\lambda=441,6$  nm. Due to this the interference pattern has a strongly damping character inside of the photosensitive medium. Thus, the standing vector wave in reality will have heterogeneous character inside photosensitive medium. In particular, the condition  $\vec{E}_+ = \vec{E}_-$  does not hold inside the photosensitive material and the vector of the interference field, in reality, describes an ellipse with ellipticity changing along the standing wave. In this case the anisotropy (Weigert's effect) will be created only because of the difference between of intensities along the big and small axes of the ellipse. Therefore, linearity of the polarization is achieved only for the middle area of the photosensitive medium, in the interference pattern ( $d/2$ ), where the intensity already is very low. Thus, the modulation depth of such anisotropic structure and accordingly its diffractive efficiency will be also low. In practice, the maximum value of the birefringence induced by light in the azo-dye materials reaches  $\Delta n \approx 0.01$ , which is enough to obtain higher efficiency. If the recording takes place in a wavelength range, where the absorption of the photosensitive material is much lower

( $\lambda=488.0$  nm and  $\lambda=514.5$  nm), the polarization in the interference pattern is near to linear. In addition, the intensity of the interference pattern, in the photosensitive layer, in this case, will be higher, and thus the result of the Weigert's effect will be also larger. Accordingly, the diffraction efficiency of such structure may reach higher values.

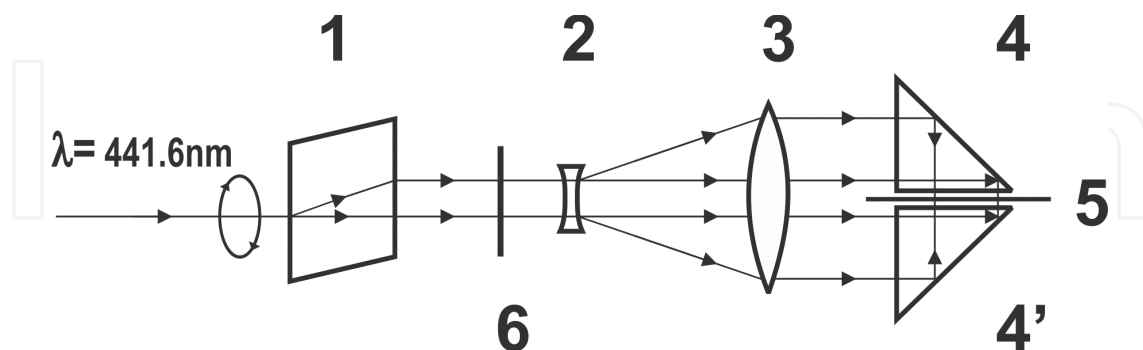

Fig. 17. The scheme of the recording of the holographic chiral structure

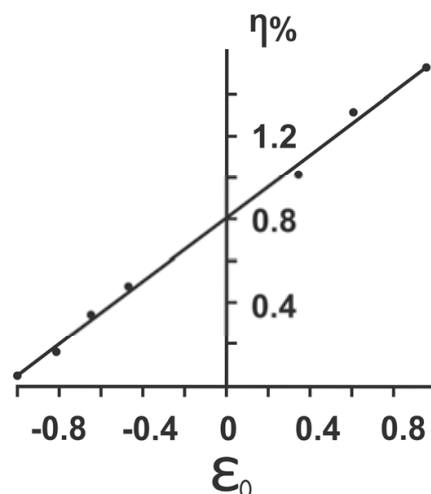

Fig. 18. The diffractive efficiency dependence on the ellipticity of the falling wave.

## 5. Selfrecording phenomenon

As it was noted, the use of photosensitive materials with the effect of Weigert gives a possibility of holographic recording, under the modulation of interference pattern only with state of polarization. One of the known examples of this is the interference of two waves with orthogonal circular polarizations. The schematic images of interference pattern for equal intensities and different intensities of the interfering waves in this case is shown in Fig. 19 a, b, (Kakichashvili, 1974). The investigations of some authors showed that the holographic recording in similar conditions in azo-dye materials provides 100% diffraction efficiency of thin holograms (Shatalin&Kakichashvili, 1987). In this case the reconstructed wave is polarized also circularly, but orthogonally to the reconstructing wave. It should be noted that one of the important results of the mentioned holographic process is that the diffraction efficiency of holograms increases continuously, reaches a maximum and remains constant on the whole further process of recording. Therefore, overexposure, in this case, does not take place and it is observed in all of the azo-dyes (Todorov et al., 1984;

Naydenova, L. et al., 1998). It is interesting the influence of the diffracted light on the dynamic process of holographic recording. In particular, at sufficiently high diffraction efficiency holograms ( $\eta > 10\%$ ), the intensity of the diffracted light is close to the intensity of the recording beams. Accordingly, the diffracted wave may create the additional interference pattern together with basic interference pattern and can provide the additional holographic recording. Therefore, the wave diffracted by the hologram can have an influence on the dynamic of holographic recording. Observation of this influence is very difficult in the process of holographic recording. However, it should be more pronounced on the stage of the reconstruction process. In particular, after blocking one of the waves in the recording process, the interaction of the diffracted wave with the second beam will create its own interference pattern, which can create sufficient conditions for the additional process of holographic recording. This process may be named as the self-recording phenomenon.

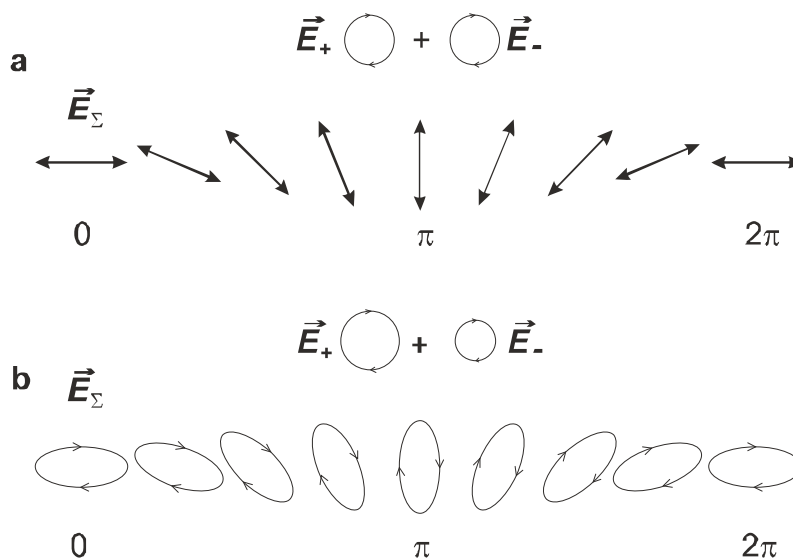

Fig. 19. Interference of two wave with orthogonal circular polarizations.

For the verification of this assumption, holographic recording in coincident beams with orthogonal circular polarization was realized. As the photosensitive material azo-dye colored gelatin was used. The optical scheme of the experimental equipment is presented on the Fig. 20. Passing through  $\lambda/4$  - phase plate **1**, the linearly polarized beam of **Ar** laser ( $\lambda=488, 0$  nm) divides into two orthogonally linearly polarized beams by means of polarization Rochon prism **2**. The rotation of  $\lambda/4$  - phase plate **1** allows varying the ratio of intensities of these beams. The collecting lens **3**, creates two diverging beams of light propagating parallel to each other. The second  $\lambda/4$  - phase plate **4** converts the orthogonal linear polarization of the beams into orthogonal circular polarization. The second collecting lens **5** forms two collimated beams with orthogonal circular polarizations, converging on the plane of the photosensitive medium **6**. Described scheme enables the realization of holographic recording at different ratios of the intensities of the interfering beams. Non-destructive readout was carried out with linearly polarized radiation **7 He-Ne** laser ( $\lambda= 632,8$  nm), which is directed perpendicular to the hologram **8**. In the beginning, the holographic recording was carried out, when the intensities of interfering waves were equal. The resulting hologram represents a diffraction grating with anisotropic structure, where the distribution of the anisotropy direction corresponds to the distribution of linear polarization direction in the interference pattern.



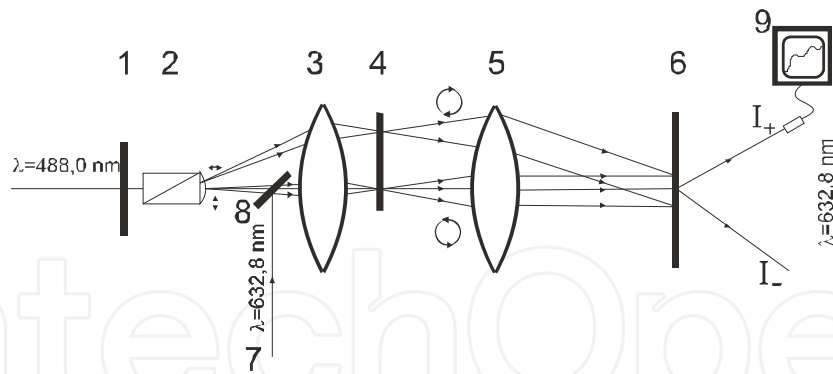

Fig. 20. The scheme of the dynamic holographic recording

The intensities of the  $\pm I$  orders of the diffracted wave ( $\lambda=632,8$  nm) were measured by means of recorder 9, for the control of the dynamic processes of holographic recording and reconstruction. Fig.21 shows the results of investigation of the dynamic processes of holographic recording and reconstruction at equal intensities of the recording waves in the cases of:

- I** - orthogonal circular polarizations of the recording waves - curve 1 (only recording process);
- II** - orthogonal circular polarizations of recording waves - curves 2 **a**, **b** (recording - **a**, and reconstruction - **b** by means of actinic light);
- III** - collinear circular polarizations of recording waves - curves 3 **a'**, **b'** (recording - **a'**, and reconstruction - **b'** by means of actinic light).

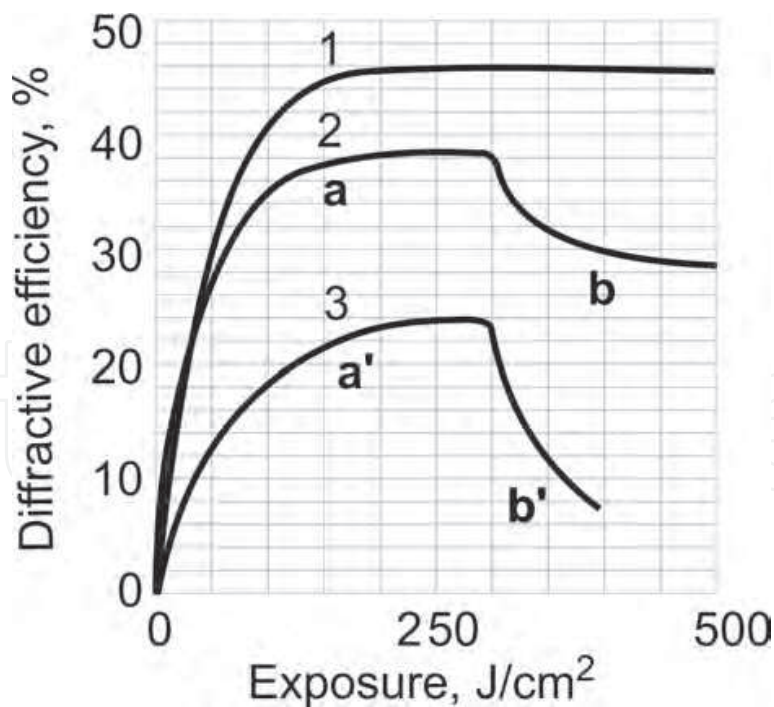

Fig. 21. The dynamic of the holographic recording and reconstruction

The interference pattern, in the cases I and II of holographic recording, is modulated only by polarization and, vice versa, in the case III is modulated only by intensity. Curve 1, reflects only recording process, and shows that the diffractive efficiency of hologram increases

continuously, reaches the maximum value and maintains it during the whole further process of recording. Curve 2 shows that the diffractive efficiency is increasing, analogically as in the case I (curve 2 a), but decreases after blocking one of the recording beams (curve 2 b). Similarly, curve 3 shows that the diffractive efficiency is rising in the beginning in the case III for the collinear circular polarization of the recording waves (curve 3 a') and decreases after interrupting one of the interfering waves similarly to the case II (curve 3 b'). However, despite the similarity, the important difference between the processes II and III, described by the curves 2 and 3, is obvious. In particular, from Fig. 21 follows that the maximum value of diffractive efficiency is almost twice as much for the orthogonal circular polarization of the recording waves, than for their collinear circular polarizations. It means that the holographic structure with modulation of anisotropy is more efficient than the isotropic structure. From the point of view of the investigated problem, a more important difference between the mentioned processes is that the diffractive efficiency in the reconstruction stage for the anisotropic hologram, produced in orthogonal circular polarizations of the recording waves, decreases much slower than for isotropic hologram, which is recorded in the collinear circular polarizations of the recording waves. The only explanation of such sharp difference between the results of reconstruction can be the difference between the rates of the erasure and the rate of the new holographic recording. Namely, because of great diffractive efficiency of hologram with an anisotropic structure, the intensity of the diffracted part of the actinic light, is closer to the intensity of the falling light, passing through hologram. Accordingly, after blocking of one of the recording beams, the diffracted wave creates a new interference pattern together with the reconstructing wave, which can stimulate the additional process of holographic recording. Consequently, it is clear that the dynamic of the reconstruction process, will depend on the ratios between the process of deletion and the secondary process of the recording. It turned out, that the difference between the intensities of the circularly orthogonally polarized waves of recording, is the most important condition for observation of the process of self-recording (Fig.22). Curve 1 corresponds to the diffraction efficiency of hologram for the ratio of intensities  $I_+/I_-=1/2$  of the recording waves and curve 2 corresponds to the ratio of  $I_+/I_-=1/3$ .

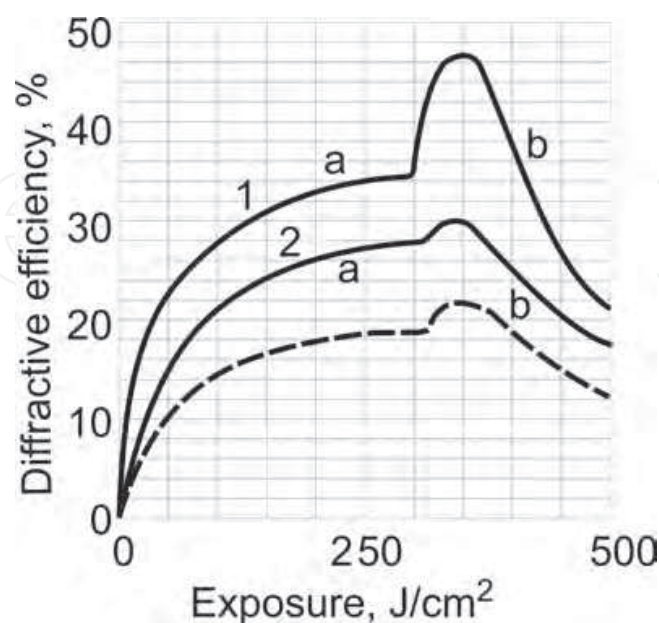

Fig. 22. The dynamic of the holographic recording and reconstruction

The wave with lower intensity was blocked in both cases of holographic process at the moment of reaching the maximum diffractive efficiency (curves 1 and 2 a). The +I-order of diffracted sensing wave with more high intensity was measured for the observation of the reconstruction process. From Fig.22 follows the instant increase of the diffractive efficiency, which reaches its maximum value in a short interval of time and then decreases in an ordinary way (curves 1 and 2 b). At the same time the investigations show that the optimum of the self-recording corresponds to the ratio of  $I_+/I_-=1/2$  of the intensities of the recording waves. It must be noted also that the diffraction picture has asymmetrical character in the recording process, i.e. intensities of diffracted  $\pm I$ -orders of the sensing wave ( $\lambda=632,8$  nm) are different. The process of self-recording, was also observed during the measurement of the less intensive -I-order of diffraction of the sensing wave (dotted line in Fig.22). It indicates that the observed phenomenon is not a result of the usual redistribution of intensities between  $\pm I$  - orders of diffracted waves. It is important that the obtained result is not observed at the holographic recording by means of waves of the other polarizations except of orthogonal circular.

Let us consider one of the possible explanations of obtained results. As it was mentioned above, in the case of equal intensities of the circularly orthogonally polarized recording waves, the interference pattern has linear polarization whose orientation changes depending on the phase difference between the interfering waves. Such an interference pattern generates the adequate distribution of anisotropy in the photosensitive medium with Weigert's effect. It is clear that the maximum of the diffraction efficiency of similar hologram corresponds to the maximum of anisotropy (Weigert's effect). Obtained hologram is exposed impact only by one beam with circular polarization after blocking one of the recording waves when its diffractive efficiency is already maximal. The diffracted wave provides the establishment of new interference pattern, which may initiate continuation of the holographic recording process. However, the further increasing in the diffractive efficiency must not be take place, because the value of anisotropy already reached maximum value. Accordingly, the additional holographic recording can only lead to the decrease in speed erasing process (curves 2 a, b and 3 a', b' of Fig.22). Unlike the previous case, if the intensity of the recording waves are different, the interference pattern will be elliptically polarized. The orientation of ellipse varies depending on the phase difference between interfering waves in this case. Because the photosensitive material has anisotropic response, created anisotropic structure is similar to previous one, but maximum value of anisotropy must be lower, as a result of competing effects in orthogonal directions along the ellipse axes. Therefore, the maximum value of the diffractive efficiency of the hologram is also lower in this case. Accordingly, we can assume that such holographic structure should have a resource to further increase the magnitude of the anisotropy and, thus, for the future increase in its diffraction efficiency. Simple experimental investigation of dynamic processes of Weigert's effect in azo dyes, with linear and elliptical polarization of actinic light ( $\lambda=488, 0$  nm), was carried out to test this assumption. To estimate the created anisotropy, with help of the recorder, transparency of the samples placed between crossed polarizers, at a wavelength of  $\lambda= 632,8$  nm was measured. Polarization of the actinic light waves were chosen in such away that the direction of the electric vector of linearly polarized light ( $\vec{E}_{YL}$ ) and the direction of the electric vector of the elliptically polarized light ( $\vec{E}_{YE}$ ), oscillating along the main axis of the ellipse coincided and were oriented vertically (OY axes). In addition (Fig. 23), the intensity of the beams were chosen so that the electric vector of

linearly polarized light  $\vec{E}_{YL}$  (Fig. 23 a) and component's of electric vector  $\vec{E}_{YE}$  of the elliptically polarized light (Fig. 23 b), along the main axis, were equal. So the intensity of the linearly polarized beam, as well as, the intensity of elliptically polarized beam, were equal in the direction of the axis OY. Polarization of the sensing wave ( $\lambda = 632,8$  nm) is oriented at the angle of  $45^\circ$ , regarding to axis OY. The results of the investigation are presented in Fig. 24. Curve 1 shows the dynamics of increasing of anisotropy in the light-sensitive material for the linear polarization of the actinic light ( $\lambda = 488,0$  nm). Curve 2 a corresponds to similar dependence, for the elliptical polarization of actinic light. As follows from these results despite the great intensity, the maximum value of anisotropy, created by elliptically polarized light is significantly lower, than the anisotropy created by linearly polarized light with lower intensity. However, under additional irradiation of the sample (which already was irradiated up to saturation, by means of elliptically polarized light) by means of linearly polarized actinic light, the electric vector of which directed along the main axis of the ellipse of polarization, the value of the anisotropy increases again (curve 2 b). Thus, when the interference pattern has elliptical polarization, the anisotropy of holographic structure which is created, has an additional resource to further increase of its anisotropy. After the blocking of the beam of lower intensity, in the process of holographic recording, when the diffractive efficiency is maximum, the diffracted beam creates the interference pattern (with the second recording wave), with polarization close to linear. Therefore, this interference pattern may initiate a further increase in anisotropy of the hologram and accordingly the further increase of its diffraction efficiency, i.e. of the self-recording process.

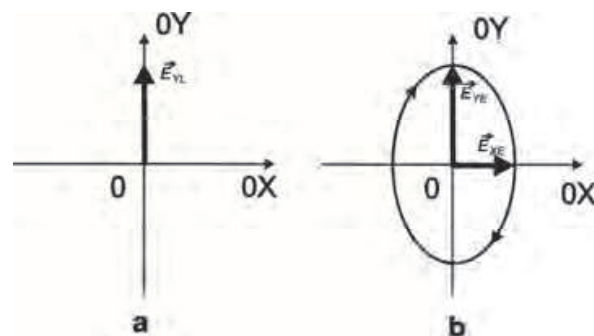

Fig. 23. The schematic picture of creation of the Weigert's effect by the linearly polarized (a) and elliptically polarized (b) light.

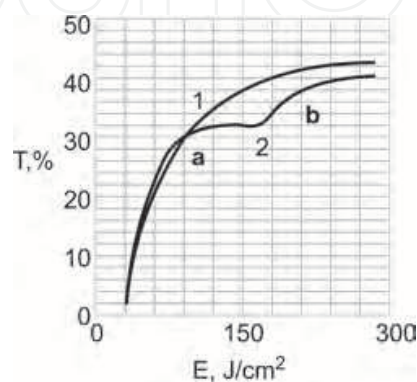

Fig. 24. The dynamic of the Weigert's effect



## 6. Holographic recording in unpolarized light

After passing of anisotropic or gyrotropic transparent objects, unpolarized light changes its statistical polarization structure. In this case the interaction with the initial reference wave gives interference pattern, which is modulated by intensity, as well as by polarization. Application of photosensitive material with Weigert's effect gives a possibility of holographic registration of above mentioned change of unpolarized light. For the verification of this assumption the corresponding holographic recording was carried out. As the simple anisotropic and gyrotropic objects can be use corresponding phase plates. It is also known that the interference pattern becomes to evenly lit if on the way of one of the interfering unpolarized waves put an anisotropic half-wave or gyrotropic half-wave (rotator at  $90^\circ$ ) phase plate (Langsdorf&Du Bridge, 1931; Vavilov, 1932). However, the polarization analysis shows that the total interference pattern is modulated with the polarization state. The optical scheme of holographic recording is shown in Fig. 25. The collimated beam of the He-Cd ( $\lambda=441.6$  nm) by means of the Fresnel biprism **1** splits into two beams that overlapping in the plane of the photosensitive material **2**. Azo-dye doped gelatin was used as photosensitive material. On the way of one of the interfering wave the half-wave phase plate **3** was placed. The microlens **4** and the polarizer **5** allow to view the interference pattern and carry out its polarization analysis. In the absence of the half-wave phase plate, the interference pattern is modulated only by intensity, and its bright areas are also unpolarized (Fig. 26 a). After placing of the phase plate the modulation of interference pattern by the intensity disappears and it becomes uniformly illuminated (Fig. 26 b). However, the polarization analysis shows that the interference pattern is modulated with the polarization.

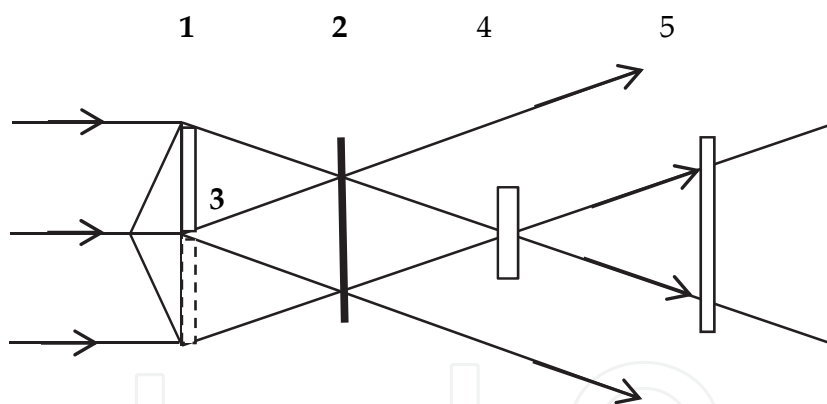

Fig. 25. The scheme of the holographic recording.

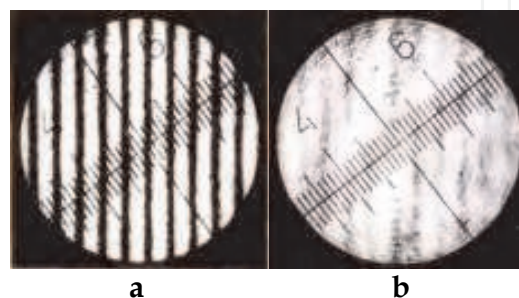

Fig. 26. Interference pattern of unpolarized light without (a) and with (b)  $\lambda/2$  anisotropic phase plate.

Fig. 27 shows the image of the interference pattern in three different orientation of the polarizer. Fig. 27 **a** shows the image of the interference pattern when the polarizer, is oriented along to the fast axis of the phase plate. Fig. 27 **b** shows the image of the interference pattern when the polarizer is oriented at the angle of  $45^\circ$  to the fast axis of the phase plate. Fig. 27 **c** shows the image of the interference pattern when the polarizer is oriented at the angle  $90^\circ$ . From Fig. 27 **a** and **c** follows that there is a shift of the interference fringes as a result of changing the orientation of analyzer by  $90^\circ$ . This testifies the existence in the interference pattern of two linear polarizations of orthogonal orientation. It is clear that under intermediate orientation of analyzer, the interference pattern will have uniform luminosity, which is confirmed by Fig. 27 **b**. Therefore, the ordinary photosensitive materials without Weigert's effect will not register such interference pattern. Thus, for realization of holographic recording in this case the application of the photosensitive material with Weigert's effect is necessary. The maximum of the diffraction efficiency of created holographic grating reached 10%. It is obviously that the greatest interest in this experiment represents comparison of polarization characteristics of the recorded object wave with that of the reconstructed wave. Investigation showed that reconstructed wave is also unpolarised. From this point of view is interesting to compare the statistical polarization structures of the wave formed with the help of half-wave plate and of its holographic reconstruction. For the comparison, the half-wave phase plate was removed. The object wave was blocked and with the help of micro lens 5 and polarizer 6, the interference pattern between reconstructed and reference waves after hologram was observed. To obtain of equal intensities of interfering waves, in this case, the intensity of the reference wave was decreased with the help of a neutral light filter. The results of the investigation is presented in Fig. 28 **a,b, c**, which is practically identical to the results represented on Fig. 27 **a,b,c**.

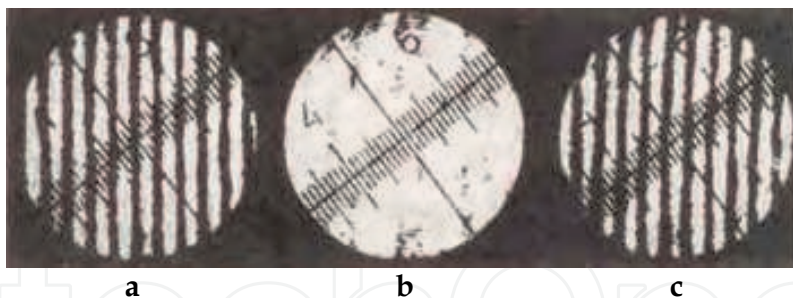

Fig. 27. The interference pattern with  $\lambda/2$  anisotropic phase plate after polarizer

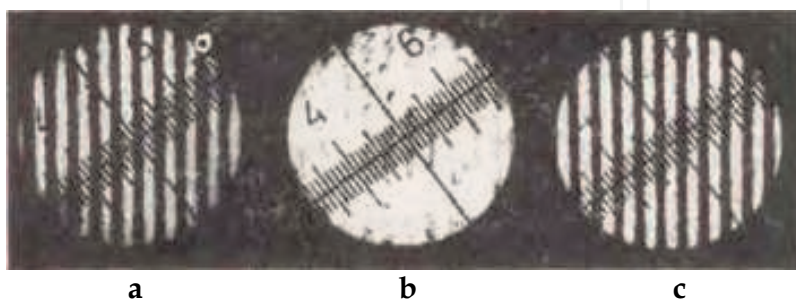

Fig. 28. The interference with the reconstructed image of the  $\lambda/2$  anisotropic phase plate after polarizer



These results confirm that holographic recording in the unpolarized light, on the basis of Weigert's effect, when the object wave is forming with the help of half-wave anisotropic phase plate, gives a possibility of the adequate reconstruction of the changing of statistical polarization structure of unpolarized wave.

As noted above, if the unpolarized object wave is formed with the help of half-wave gyrotropic phase plate the interference pattern contains two mutually orthogonal circular polarization. In this case, when as a recording medium a photosensitive material with Weigert's effect is used, the holographic recording was impossible. Obtained results show that for holographic recording of full information about the wave scattered by the object, in general, Weigert's effect is insufficient and here is needed a photosensitive material with gyrotropic response.

In spite of this, the holographic recording in unpolarized light, extends considerably the possibilities of holography. One of the specific examples of the use of unpolarized light in holography is the solution to some problems of photoelasticity.

The holographic recording for strained transparent object was investigated experimentally, by means of unpolarized light. At the first stage of holographic recording, the photosensitive material was dichromated gelatin without the Weigert's effect. The reconstructed image is shown in Fig. 29 a. This image represents a picture of the isochromes. At the second stage, on the path of the reference wave the half-wave anisotropic phase plate was placed. The reconstructed image of the object, in this case, are represented in Fig 29 b,c. Fig. 29 b corresponds to holographic recording, when the optical axis of the phase plate is oriented vertically. Fig. 29 c corresponds to holographic recording, when the optical axis of the phase plate is oriented at an angle of 45 degrees to the vertical. These images represent the picture of the isochromes and isoclines. From Fig. 29 follows that, the reconstructed image contains some information about the distribution of anisotropy in the object. If on the way of reference wave is placed the half-wave gyrotropic phase plate (quartz rotator  $90^\circ$ ) the holographic recording does not take place in this photosensitive material.

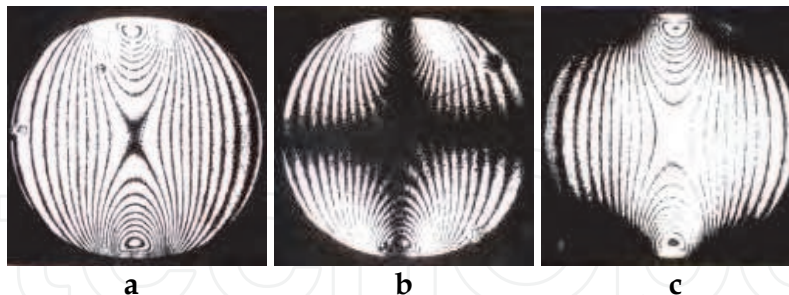

Fig. 29. The reconstructed image of the strained transparent object.

In the next stage of holographic recording, as a photosensitive material, was used azo-dye doped gelatin with Weigert's effect. The reconstructed images are represented in Fig. 30 a,b,c. Fig.30 a correspond to the holographic recording without phase plate. In this case, the reconstructed image has practically an uniform illumination. Fig.30 b represents the reconstructed image when on the way of the reference wave, in the process of holographic recording, half-wave anisotropic phase plate was placed. Here is clearly observed the pattern of isochromes and isoclines. So, from Fig. 30 a and b follows that these images represent complementary images of isochromes and isoclines, which are shifted on the one lane relative to each other. The first part of isochrome is the result of holographic recording

with the help of unpolarized parts of interference pattern. The second part of isochrome is the result of holographic recording caused by influence of linearly polarized parts of interference pattern. This assumption is confirmed in Fig. 30 c. It represents the reconstructed image, when on the way of the reference wave, in the process of holographic recording, was placed a half-wave gyrotropic phase plate (quartz rotator  $90^\circ$ ), when the interference pattern consists of circularly and linearly polarized parts. Fig. 30 c shows picture only of the second part of isochromes, which is the result of holographic recording caused by influence of only linearly polarized parts of interference pattern. From the final result follows that, photosensitive material with the Weigert's effect can not register circularly polarized component of the interference pattern. Because of this we may conclude that to fully solve of this task of holography it is necessary to use a photosensitive material with gyrotropic response.

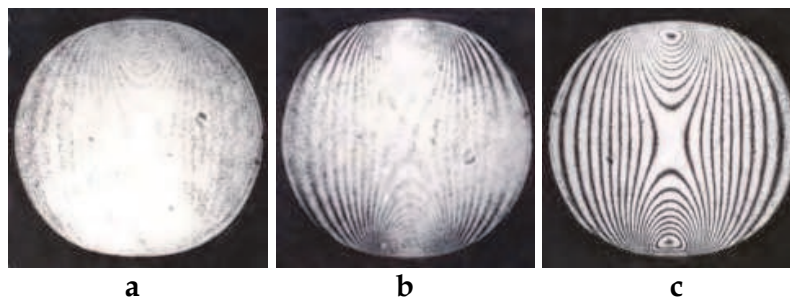

Fig. 30. The reconstructed image of the strained transparent object.

## 7. Conclusion

From the results described above it can be concluded that the holography based on the Weigert's effect has the following advantages:

- 7.1 Holographic recording and reconstruction of the polarization in some particular cases.
- 7.2 Holographic recording and reconstruction of statistical polarization structure of unpolarized light.
- 7.3 The possibility of creation of the holographic diffractive optical elements with anisotropic structure with advanced features.
- 7.4 Some new processes (for example selfrecording) in the investigation of dynamic processes of holographic recording based on the Weigert's effect.
- 7.5 Some new approaches in investigation of mechanisms of Weigert's effect in the Azodyes.

## 8. Acknowledgment

I would like to express my great love to my mother Neburishvili L.K., which helps me in all my life and express my gratitude to the late Professor Kakichashvili Sh.D. with whom I had the privilege to work in the years 1982-1992.

## 9. References

Gabor, D. (1948). A New Microscope Principle, *Nature*, vol.161, pp. 777-778.

- Leith, E.N.; Upatnieks, I. (1962). Reconstructed wave fronts and communication theory. *JOSA*, vol.52, № 11, pp.1123-1130.
- Denisiuk, J.N. (1963). On the mapping of the optical properties of the object of the wave field scattered light from them. *Opt. & Spectr.*, vol. 15, № 4, pp.522-532, (Russian).
- Born, M., Wolf, E. (1970). *Principles of Optics*, NAUKA, Moscow, (Russian).
- Langsdorf, A., Du Bridge, I. (1931). Rotation of polarization in the unpolarized light. *JOSA*, vol. 21, pp.1-4,.
- Vavilov, S.I. (1932). Proceedings, About the inside structure of unpolarized light. Ad. Sc. of USSR, ser.7, №9, pp.1451-1458, (Russian).
- Weigert, F. (1919). Über Einen Neuen Effect der Strahlung in Lichtempfindlichen Schichten, *Verhandl. Dt. Physik. Ges.*, bd.21, ss. 479-483 (German).
- Kondo, T. (1932). Über den Photoanisotropen Effect (Weigert-effect) an Farbstoffen. *I//Z. Wissenschaftliche Photogr., Photophys. Und Photochem.*, bd.31, H. 6, ss. 153-267 (German).
- Zocher, H., Coper K. (1928). Über die Erzeugung optischer Aktivität durch Zirkulares Licht. *Z.Phys.Chem.*, Bd.132, S.313-319 (German).
- Kakichashvili, Sh. D. (1972). On Polarization Recording of Holograms. *Opt. & Spectr.*, vol.1, No.6, pp. 324-327, (Russian).
- Eltsov, A.V. (1982). *Organic Photochromes*, Chimia, Leningrad, p. 285, (Russian).
- Vasilieva N.V. et al 1978, *Practical Works In Organic Chemistry*, Prosveshchenie, Moscow, p. 303, 1978 (Russian).
- Shatalin, I.D. (1989). To Mechanisms of Photoanisotropy In Photochemical Trans-Cis isomerisation. *Optics & Spectr.*, Vol.66, No.2, pp.362-364. (Russian).
- Ebralidze, T.D., Ebralidze, N.A., Bazadze. (2002). M.A., Weigert's effect Mechanism Observed In Dyes. *Appl. Opt.*, Vol.41, No.1, pp.78-79.
- Kakichashvili, Sh. D., Shaverdova, V, G. (1979). Photoanisotropy in Mordant Yellow Azo-Dyes. *Jorn. of Sci. and Appl. Phot. and Cinematograph*, Vol. 24, No.5, pp. 342-345, (Russian).
- Jones, R.C. (1941). A New Calculus for the Treatment of Optical Systems. *J. Opt. Soc. Amer.*, vol.31, No.7, 488-493.
- Kakichashvili, Sh.D. (1974). Method of Polarization Recording of Holograms. *Kvantovaja Electron (Quant. Electr.)*, vol.1, N 6, pp.1435-1441, (Russian).
- Shatalin, I.D., Kakichashvili, Sh.D. (1987). Polarization hologram with 100% diffractive efficiency (polarization cinoform). *Pisma v JTF (Sov. Tech. Phys. Lett.)*, vol.13, No.17, 1051--1055, (Russian).
- Todorov et al., 1984, Polarization holography. 2: Polarization holographic gratings in photoanisotropic materials with and without intrinsic birefringence, *Appl. Opt.* vol. 23, Issue 24, 4588-4591.
- Naydenova, L. et al., 1998., Diffraction from polarization holographic gratings with surface relief in side-chain azobenzene polyesters, *J. Opt. Soc. Am. B* Vol. 15, Issue 4, 1257-1265.
- Jones, R.C. (1948). New Method of Calculation of Optical Systems. VIII. Properties of N - matrixes. *Journ. Opt. Soc. Amer.*, vol.38, 671-684.
- Dawson, F.F., Young, N.O. (1960). Helical Kerr Cell". *Journ. Opt. Soc. Amer.*, vol.50, 170-171.
- Chilaya, G. et al (1997). New Pretransitional Liquid Crystal Phase With Anomalous Selective Reflection. *Mol. Materials*, Vol.8, pp. 245-255.
- Laktakia A., Messier, R. (2005). Sculptured thin films: nanoengineered morphology and optics. SPIE Press., vol.PM142, ISBN 978-0-8194-5606-9.

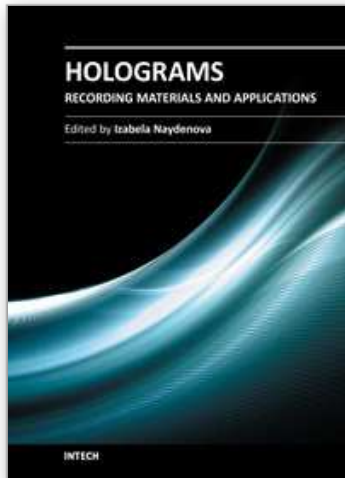

## **Holograms - Recording Materials and Applications**

Edited by Dr Izabela Naydenova

ISBN 978-953-307-981-3

Hard cover, 382 pages

**Publisher** InTech

**Published online** 09, November, 2011

**Published in print edition** November, 2011

Holograms - Recording Materials and Applications covers recent advances in the development of a broad range of holographic recording materials including ionic liquids in photopolymerisable materials, azo-dye containing materials, porous glass and polymer composites, amorphous chalcogenide films, Norland optical adhesive as holographic recording material and organic photochromic materials. In depth analysis of collinear holographic data storage and polychromatic reconstruction for volume holographic memory are included. Novel holographic devices, as well as application of holograms in security and signal processing are covered. Each chapter provides a comprehensive introduction to a specific topic, with a survey of developments to date.

### **How to reference**

In order to correctly reference this scholarly work, feel free to copy and paste the following:

Zurab V. Wardosanidze (2011). Holography Based on the Weigert's Effect, Holograms - Recording Materials and Applications, Dr Izabela Naydenova (Ed.), ISBN: 978-953-307-981-3, InTech, Available from: <http://www.intechopen.com/books/holograms-recording-materials-and-applications/holography-based-on-the-weigert-s-effect>

**INTECH**  
open science | open minds

### **InTech Europe**

University Campus STeP Ri  
Slavka Krautzeka 83/A  
51000 Rijeka, Croatia  
Phone: +385 (51) 770 447  
Fax: +385 (51) 686 166  
[www.intechopen.com](http://www.intechopen.com)

### **InTech China**

Unit 405, Office Block, Hotel Equatorial Shanghai  
No.65, Yan An Road (West), Shanghai, 200040, China  
中国上海市延安西路65号上海国际贵都大饭店办公楼405单元  
Phone: +86-21-62489820  
Fax: +86-21-62489821

© 2011 The Author(s). Licensee IntechOpen. This is an open access article distributed under the terms of the [Creative Commons Attribution 3.0 License](#), which permits unrestricted use, distribution, and reproduction in any medium, provided the original work is properly cited.

IntechOpen

IntechOpen