

We are IntechOpen, the world's leading publisher of Open Access books Built by scientists, for scientists

6,900

Open access books available

186,000

International authors and editors

200M

Downloads

Our authors are among the

154

Countries delivered to

TOP 1%

most cited scientists

12.2%

Contributors from top 500 universities



WEB OF SCIENCE™

Selection of our books indexed in the Book Citation Index
in Web of Science™ Core Collection (BKCI)

Interested in publishing with us?
Contact book.department@intechopen.com

Numbers displayed above are based on latest data collected.
For more information visit www.intechopen.com



Experimental Prediction of Heat Transfer Correlations in Heat Exchangers

Tomasz Sobota
Cracow University of Technology
Poland

1. Introduction

Heat exchangers is a broad term related to devices designed for exchanging heat between two or more fluids with different temperatures. In most cases, the fluids are separated by a heat-transfer surface. Heat exchangers can be classified in a number of ways, depending on their construction or on how the fluids move relative to each other through the device. The use of heat exchangers covers the following areas: the air conditioning, process, power, petroleum, transportation, refrigeration, cryogenic, heat recovery, and other industries applications. Common examples of heat exchangers in everyday use are air preheaters and conditioners, automobile radiators, condensers, evaporators, and coolers. (Kuppan, 2000).

Many factors enter into the design of heat exchangers, including thermal analysis, size, weight, structural strength, pressure drop, and cost. Cost evaluation is obviously an optimization process dependent upon the other design parameters (Pitts & Sissom, 1998). Economics plays a key role in the design and selection of heat exchanger equipment, and the engineer should bear this in mind when taking up any new heat transfer design problem. The weight and size of heat exchangers are significant parameters in the overall application and thus may still be considered as economic variables (Holman, 2009; Shokouhmand et al., 2008; Rennie & Raghavan, 2006).

Calculations of heat exchangers can be divided into two categories, namely, thermo-hydraulic and mechanical design calculations. The subject of thermal and hydraulic calculations is to determine heat-transfer rates, heat transfer area and pressure drops needed for equipment sizing. Mechanical design calculations are concerned with detailed equipment specifications, including stress analyses.

Heat exchanger problems may also be considering as rating or design problems. In a rating problem, should be determined whether particular exchanger will perform a given heat-transfer duty adequately. It is of no importance whether the exchanger physically exists or whether it is specified only on paper. In a design problem, one must determine the specifications for a heat exchanger that will handle a given heat-transfer duty. A rating problem also arises when it is desired to use an existing heat exchanger in a new or modified application (Serth, 2007). A particular application will dictate the rules that one must follow to obtain the best design commensurate with economic considerations, size, weight, etc. They all must be considered in practice (Holman, 2009; Shokouhmand et al., 2008; Rennie & Raghavan, 2006).

2. Thermal design of the heat exchangers

The suitable use of heat transfer knowledge in the design of practical heat transfer equipment is an art. Designers must be constantly aware of the differences between the idealized conditions under which the fundamental knowledge was obtained and the real conditions of their design and its environment. The result must satisfy process and operational requirements and do so cost-effectively. An important element of any design process is to consider and compensate the consequences of error in the basic knowledge, in its subsequent incorporation into a design method. Heat exchanger design is not an extremely accurate procedure under the best of conditions (Shilling et al., 1999).

The design of a heat exchanger usually consists of the subsequent steps:

1. Specification of the process conditions, e.g. flow compositions, flow rates, temperatures, pressures.
2. Obtaining of the required physical properties over the temperature and pressure ranges of interest obtained.
3. Choosing the type of heat exchanger that is going to be used.
4. An initial estimation of the size of the heat exchanger that is made, using a heat transfer coefficient appropriate to the fluids, the process, and the equipment.
5. A first design is chosen, complete in all details necessary to carry out the design calculations.
6. Evaluation of ability to perform the process specifications with respect to both heat transfer and pressure drop as the design of heat exchanger is chosen.
7. Described in point above procedure can be repeated to new heat exchanger design if it is necessary. The final design should meet process requirements within reasonable error expectations.

The calculation of convective heat transfer coefficients constitutes a crucial issue in designing and sizing any type of heat exchange device. Thus its correct determining permits for the proper selection of heat transfer area during designing of heat exchangers and calculation of the fluids outlet temperature. A lot of efforts have been made during experimental investigations of pressure drop and heat transfer in different types of heat exchangers to obtain proper heat transfer correlation formulas.

2.1 The Wilson plot technique to determine heat transfer correlations in heat exchangers

One of the widely used methods for calculations of heat transfer coefficient is the Wilson plot technique. This approach was developed by E.E. Wilson in 1915 in order to evaluate the heat transfer coefficients in shell and tube condensers for the case of a vapour condensing outside by means of a cooling liquid flow inside (Viegas et al., 1998; Kumar et al., 2001; Rose, 2004; Fernández-Seara et al., 2007). It is based on the separation of the overall thermal resistance into the inside convective thermal resistance and the remaining thermal resistances participating in the heat transfer process. The overall thermal resistance $R_{overall}$ of the condensation process in a shell-and-tubes heat exchanger can be expressed as the sum of three constituent thermal resistances: R_{in} – the internal convection, R_{wall} – the tube wall and R_o – the external convection, presented in Eq. (1).

$$R_{total} = R_{in} + R_{wall} + R_o . \quad (1)$$

The thermal resistances of the fouling in Eq. (1) was neglected. Employing the expressions for the thermal resistances in Eq. (1), the overall thermal resistance can be rewritten as follows:

$$R_{total} = \frac{1}{h_{in}A_{in}} + \frac{\ln\left(\frac{d_o}{d_{in}}\right)}{2\pi\lambda_{wall}L_{wall}} + \frac{1}{h_oA_o}. \quad (2)$$

where h_{in} and h_o is the internal and outer heat transfer coefficients, d_{in} and d_o – the inner and outer tube diameters, λ_{wall} is the tube material thermal conductivity, L_{wall} is the tube length and A_i and A_o are the inner and outer tube surface areas, respectively.

On the other hand, the overall thermal resistance can be written as a function of the overall heat transfer coefficient referred to the inner or outer tube surfaces and the corresponding areas. Assuming this the overall thermal resistance is expressed as a function of the overall heat transfer coefficient referred to the inner or outer surface $U_{in/o}$ and the inner or outer surface area $A_{in/o}$ (Eq. 3)

$$R_{total} = \frac{1}{U_{in/o}A_{in/o}}. \quad (3)$$

Taking into account the specific conditions of a shell and tube condenser Wilson assumed that if the mass flow of the cooling liquid was modified, then the change in the overall thermal resistance would be mainly due to the variation of the in-tube heat transfer coefficient, while the remaining thermal resistances remained nearly constant. Therefore, as specified in Eq. (4) the thermal resistances outside of the tubes and the tube wall could be regarded as constant:

$$R_{wall} + R_o = C_1. \quad (4)$$

Wilson determined that for the case of fully developed turbulent flow inside a tube of circular cross-section, the heat transfer coefficient was proportional to a power of the reduced velocity w_r which describes the variations of the fluid property and the tube diameter. Thus, the heat transfer coefficient could be written in form:

$$h_{in} = C_2 w_r^n, \quad (5)$$

where C_2 is a constant, w_r – the reduced fluid velocity and n – velocity exponent. In this case the convective thermal resistance related to the inner tube flow is proportional to $1/w_r^n$. Inserting Eqs. (4) and (5) into Eq. (1), the overall thermal resistance becomes the linear function of $1/w_r^n$, where C_1 is the intercept and $1/(C_2A_{in})$ is the slope of the straight line. The overall thermal resistance can be calculated using experimental data using the following formula:

$$Q = U_o A_o \Delta T_{lm}. \quad (6)$$

Substituting Eq. (3) into Eq. (6), and assuming $Q = \dot{m}_1 c_{p1} (T_{1outlet} - T_{1inlet})$, where \dot{m}_1 is the mass flow rate of cooling liquid, c_{p1} – average specific heat of cooling liquid, and T_{1inlet} , $T_{1outlet}$ are inlet and outlet temperatures of cooling liquid, respectively, yields to

$$R_{total} = \frac{\Delta T_{lm}}{\dot{m}_1 c_{p1} (T_{1outlet} - T_{1inlet})} \quad (7)$$

As the constants C_1 and C_2 are determined from straight-line approximation of measured data, to evaluation, for a given mass flow rate, the internal heat transfer coefficient can be used Eq. (5) and internal heat transfer coefficient Eq. (8):

$$h_o = \frac{1}{A_o (C_1 - R_{wall})} \quad (8)$$

The original Wilson plot technique depends on the knowledge of the overall thermal resistance, that involves to remain of one fluid flow rate constant and varying flow rate of the another fluid.

Approach of Wilson plot technique to determine constant in heat transfer correlation formula for helically coiled tube-in-tube heat exchanger is presented by Sobota (Sobota, 2011).

3. Experimental prediction of heat transfer correlations in heat exchangers

In this chapter, the experimental and numerical investigations of helically coiled tube-in-tube heat exchanger are presented. Calculations of unknown constants and exponents in correlations formula for Nusselt number have been performed with least squares method using Levenberg-Marquardt algorithm. Presented method allows for determining unknown values of constants and exponents in correlation formulas for Nusselt number. This method enables to obtain values of heat transfer coefficient on both sides of the barrier simultaneously without earlier indirect calculations of the overall heat transfer.

3.1 Mathematical formulation of the inverse problem

The issue consisting of simultaneous determining of the heat transfer coefficient on the cooling and heating liquid is ranked among inverse heat transfer problems (IHCP) (Beck et al., 1985). In discussed methodology the knowledge of correlation formula form for heat transfer coefficient on the both sides of the heat transfer surface, for counter-flow and parallel-flow heat exchanger, was assumed to be known. An unknown value of the parameters in correlation formulas was hidden in equations for outlet temperature of the liquids (Nashchokin, 1980):

a) parallel-flow arrangement of heat exchanger

- heating liquid

$$T''_{1,calc} = T'_{1,meas} - (T'_{1,meas} - T'_{2,meas}) \frac{1 - e^{-\left(1 + \frac{W_1}{W_2}\right) \frac{k \cdot F_c}{W_1}}}{1 + \frac{W_1}{W_2}} \quad (9)$$

- cooling liquid

$$T''_{2,calc} = T'_{2,meas} + (T'_{1,meas} - T'_{2,meas}) \frac{W_1}{W_2} \frac{1 - e^{-\left(1 + \frac{W_1}{W_2}\right) \frac{k \cdot F_c}{W_1}}}{1 + \frac{W_1}{W_2}} \quad (10)$$

b) counterflow arrangement of heat exchanger

- heating liquid

$$T''_{1,calc} = T'_{1,meas} - (T'_{1,meas} - T'_{2,meas}) \frac{1 - e^{-\left(1 - \frac{W_1}{W_2}\right) \frac{k \cdot F_c}{W_1}}}{1 - \frac{W_1}{W_2} e^{-\left(1 - \frac{W_1}{W_2}\right) \frac{k \cdot F_c}{W_1}}} \tag{11}$$

- cooling liquid

$$T''_{2,calc} = T'_{2,meas} + (T'_{1,meas} - T'_{2,meas}) \frac{W_1}{W_2} \frac{1 - e^{-\left(1 - \frac{W_1}{W_2}\right) \frac{k \cdot F_c}{W_1}}}{1 - \frac{W_1}{W_2} e^{-\left(1 - \frac{W_1}{W_2}\right) \frac{k \cdot F_c}{W_1}}} \tag{12}$$

where $T'_{1,meas}$ and $T'_{2,meas}$ - measured temperature of the heating and cooling liquid at the inlet of the helically coiled heat exchanger respectively, °C; $T''_{1,calc}$ and $T''_{2,calc}$ - calculated temperature of the heating and cooling liquid at the outlet of the helically coiled heat exchanger respectively, °C; and expression $W = V \cdot \rho \cdot c_v$ is called as water equivalent.

The minimum of the square of the differences between measured and calculated from analytical formula temperatures of the hot fluid and differences between measured and calculated from analytical formula temperatures of the cold fluid at the outlet of heat exchanger was searching for:

$$S(\alpha) = \sum_{i=1}^n \left[(T''_{1,meas} - T''_{1,calc})^2 + (T''_{2,meas} - T''_{2,calc})^2 \right] \rightarrow \min . \tag{13}$$

In analysed example the solution of the nonlinear least square problem was searching for. Determining the values of the constants, and indirectly the values of heat transfer coefficient, was carried out using least squares method with modified Levenberg-Marquardt algorithm (Visual Numerics, 2007; Press et al., 1996).

In Levenberg-Marquardt algorithm unknown are formed an column vector $\mathbf{x} = (x_1, x_2, \dots, x_m)^T$, for which the sum becomes minimum

$$S(\mathbf{x}) = \sum_{i=1}^n [r_i(\mathbf{x})]^2 \rightarrow \min , \tag{14}$$

where $r_i(\mathbf{x}) = T''_{meas} - T''_{calc}$.

The method performs the k -th iteration as

$$\mathbf{x}^{(k+1)} = \mathbf{x}^{(k)} + \delta^{(k)} , \tag{15}$$

where

$$\delta^{(k)} = \left[\left(\mathbf{J}_m^{(k)} \right)^T \mathbf{J}_m^{(k)} + \mu^{(k)} \mathbf{I}_n \right]^{-1} \left(\mathbf{J}^{(k)} \right)^T [\mathbf{f} - \mathbf{T}_m(\mathbf{x})] , \quad k = 0, 1, \dots . \tag{16}$$

The symbols \mathbf{f} and $\mathbf{T}_m(\mathbf{x})$ stand for vector of measured and vector of computed temperature, respectively.

Jacobian determinant is described by formula

$$\mathbf{J}_m = \frac{\partial \mathbf{r}_m(\mathbf{x})}{\partial \mathbf{x}^T} = \left[\left(\frac{\partial r_i(\mathbf{x})}{\partial x_j} \right) \right]_{m \times n}, \quad (17)$$

where $i = 1, \dots, n, j = 1, \dots, m$, $\mathbf{D}^{(k)}$ denotes diagonal matrix with positive elements. Quite often $\mathbf{D}^{(k)} = \mathbf{I}_m$, where \mathbf{I}_m is identity matrix.

The value of the parameter $\mu^{(k)} \rightarrow 0$ when $\mathbf{x}^{(k)} \rightarrow \mathbf{x}^*$. In the proximity of minimum \mathbf{x}^* the iteration step in the Levenberg-Marquardt method is almost the same as in the Gauss-Newton method. The computation programs for solving the non-linear least square problem by the Levenberg-Marquardt method are described in (Lawson & Hanson, 1974) and in the IMSL Library (Visual Numerics, 2007).

3.2 Correlations for Nusselt number

Although curved pipes are used in a wide range of applications, flow in curved pipes is relatively less well known than that in straight ducts. A helical coil can be geometrically described by the coil radius R , the pipe radius r , and the coil pitch $2\pi b$ (Fig. 1).

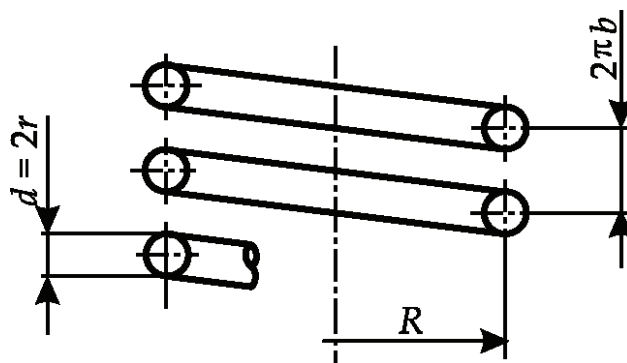

Fig. 1. Schematic representation of a helical pipe with its main geometrical parameters: r – tube radius; R – coil radius; $2\pi b$ – coil pitch

The observations on the complexity of a flow in such a channels allowed to notice the effect of curvature on the fluid flow regime which occurs delaying the transition from laminar to transitional flow to a higher Reynolds number with respect to straight pipes (Ito, 1959; Schmidt, 1967). Using data from his own experiments as well as that from previous investigations, Ito developed the following empirical relation to determine the critical Reynolds number for the range of curvature ratios of 1/15 to 1/860:

$$\text{Re}_{crit} = 20000 \left(\frac{r}{R} \right)^{0.32}, \quad (18)$$

whilst Schmidt suggested the form of critical Reynolds number listed below:

$$\text{Re}_{crit} = 2300 \cdot \left[1 + 8.6 \left(\frac{r}{R} \right)^{0.45} \right]. \quad (19)$$

For curvature ratios $\delta = r/R$ less than $1/860$, the critical Reynolds number was found to correspond with that of a straight pipe.

Equation for Nusselt number that are most commonly found in literature concerning heat transfer in curved or helical tubes can be assumed formula developed by Schmidt (Schmidt, 1967):

- for laminar regime

$$Nu = 3.65 + 0.08 \cdot \left[1 + 0.8 \left(\frac{r}{R} \right)^{0.9} \right] \cdot Re^{\left[0.5 + 0.2903 \left(\frac{r}{R} \right)^{0.194} \right]} \cdot Pr^{\frac{1}{3}}, \quad (20)$$

where Reynolds number varies $100 < Re < Re_{crit}$, where Re_{crit} is described by Eq. (19).

- for turbulent flow

$$Nu = 0.023 \cdot \left[1 + 14.8 \cdot \left(1 + \frac{r}{R} \right) \cdot \left(\frac{r}{R} \right)^{\frac{1}{3}} \right] \cdot Re^{\left[0.8 + 0.22 \left(\frac{r}{R} \right)^{0.1} \right]} \cdot Pr^{\frac{1}{3}}, \quad Re_{crit} < Re \leq 22000, \quad (21)$$

$$Nu = 0.023 \cdot \left[1 + 3.6 \cdot \left(1 - \frac{r}{R} \right) \left(\frac{r}{R} \right)^{0.8} \right] \cdot Re^{0.8} \cdot Pr^{1/3}, \quad 22000 < Re \leq 150000. \quad (22)$$

Another formulas for Nusselt number that is valid for turbulent flow was invented by Seban and McLaughlin (Seban & McLaughlin, 1963):

$$Nu = 0.023 \cdot \left(\frac{r}{R} \right)^{0.1} \cdot Re^{0.85} \cdot Pr^{0.4} \quad (23)$$

and Rogers and Mayhew (Rogers & Mayhew, 1964)

$$Nu = 0.021 \cdot \left(\frac{r}{R} \right)^{0.1} \cdot Re^{0.85} \cdot Pr^{0.4}. \quad (24)$$

Eqs. (23) and (24) have simple structure that makes them easy to use.

Other widely used method is that of Seider and Tate, who recommended the following expression for applications with large property variations from the bulk flow to the wall temperature:

$$Nu = 0.027 \cdot Re^{0.8} \cdot Pr^{1/3} \cdot \left(\frac{\mu_{bulk}}{\mu_{wall}} \right)^{0.14} \quad (25)$$

for $0.7 < Pr < 16000$, $Re > 10000$ and $L/D > 10$.

For more accurate calculations in fully developed turbulent flow it is recommended to use Petukhov heat transfer correlation that is valid for $0.5 < Pr < 2000$ and $10000 < Re < 5000000$:

$$Nu = \frac{(f/2) Re Pr}{1.07 + 12.7 (f/2)^{0.5} (Pr^{2/3} - 1)} \left(\frac{\mu_{bulk}}{\mu_{wall}} \right)^{0.14}, \quad (26)$$

where friction factor f can be obtained from the Moody diagram or from Petukhov's friction factor correlation that is valid for $3000 < Re < 5000000$:

$$f = \frac{1}{1.58 \ln(Re) - 3.28} \quad (27)$$

Another heat transfer correlation commonly used is that of Gnielinski (Smith, 1997), which extends the Petukhov correlation down into the transition regime:

$$Nu = \frac{\left(\frac{f}{2}\right)(Re-100)Pr\left(\frac{Pr}{Pr_w}\right)^{0.14}}{1 + 12.7\left(\frac{f}{2}\right)^{0.5}\left(Pr^{\frac{2}{3}} - 1\right)} \left(\frac{\mu_{bulk}}{\mu_{wall}}\right)^{0.14}, \quad (28)$$

where

$$f_c = \frac{0.3164}{Re^{0.25}} + 0.03 \sqrt{\frac{r}{R}} \cdot \left(\frac{\eta_{wall}}{\eta_{bulk}}\right)^{0.27} \quad (29)$$

Worth to be mentioned are the following heat transfer correlations:

- Mori and Nakayama (Manglik, 2003)

$$Nu = \frac{\left(\frac{r}{R}\right)^{\frac{1}{12}} \left[1 + 0.061 \left(\left(\frac{r}{R}\right)^{2.5} Re \right)^{0.167} \right] Pr^{0.4} Re^{\frac{5}{6}}}{41.0} \quad (30)$$

- Jeschke, which is the oldest one (Rogers & Mayhew, 1964)

$$Nu = 0.045 \cdot \left[1 + 3.54 \frac{r}{R} \right] \cdot Re^{0.76} \cdot Pr^{0.4} \quad (31)$$

This correlation was developed as a result of transposition formula that was valid for air flow through helical two loop heat exchanger into water.

- Kirpikov (Nashchokin, 1980)

$$Nu = 0.0456 \cdot \left(\frac{r}{R}\right)^{0.21} Re^{0.76} \cdot Pr^{0.4}, \quad 10000 < Re \leq 45000 \quad (32)$$

and Mikheev (Nashchokin, 1980)

$$Nu = 0.021 \cdot \left[1 + 1.77 \cdot \left(\frac{r}{R}\right) \right] \cdot Re^{0.85} \cdot Pr^{0.43} \quad (33)$$

The discussed correlations can be helpful in selecting the form of the heat transfer correlation in which certain coefficients and exponents are to be determined.

3.3 Experimental setup

To determine the Nusselt number correlation for forced convection in helically coiled tube-in-tube heat exchanger an experimental setup was build. It consisted of copper made heat exchanger, electric heater and circulating pumps.

3.3.1 Heat exchanger

Helical coil heat exchangers are one of the most common equipment found in many industrial applications ranging from chemical and food industries, power production, electronics, environmental engineering, air-conditioning, waste heat recovery and cryogenic processes. Helical coils are extensively used as heat exchangers and reactors due to higher heat and mass transfer coefficients, narrow residence time distributions and compact structure. The modification of the flow in the helically coiled tubes is due to the centrifugal forces (Dean, 1927, Dean, 1928). The curvature of the tube produces a secondary flow field with a circulatory motion, which causes the fluid particles to move toward the core region of the tube. The secondary flow increases heat transfer rates as it reduces the temperature gradient across the cross-section of the tube. Thus there is an additional convective heat transfer mechanism, perpendicular to the main flow, which does not exist in conventional heat exchangers. An extensive review of fluid flow and heat transfer in helical pipes has been presented in the literature (Kumar et al. 2008; Shah & Joshi, 1987).

The examined heat exchanger was constructed from copper tubing and typical connections were made of copper also and consisted of 6.5 loop. The outer tube of the heat exchanger had an outer diameter of 35 mm and a wall thickness of 1.5 mm. The inner tube had an outer diameter of 22 mm with wall thickness of 1 mm.

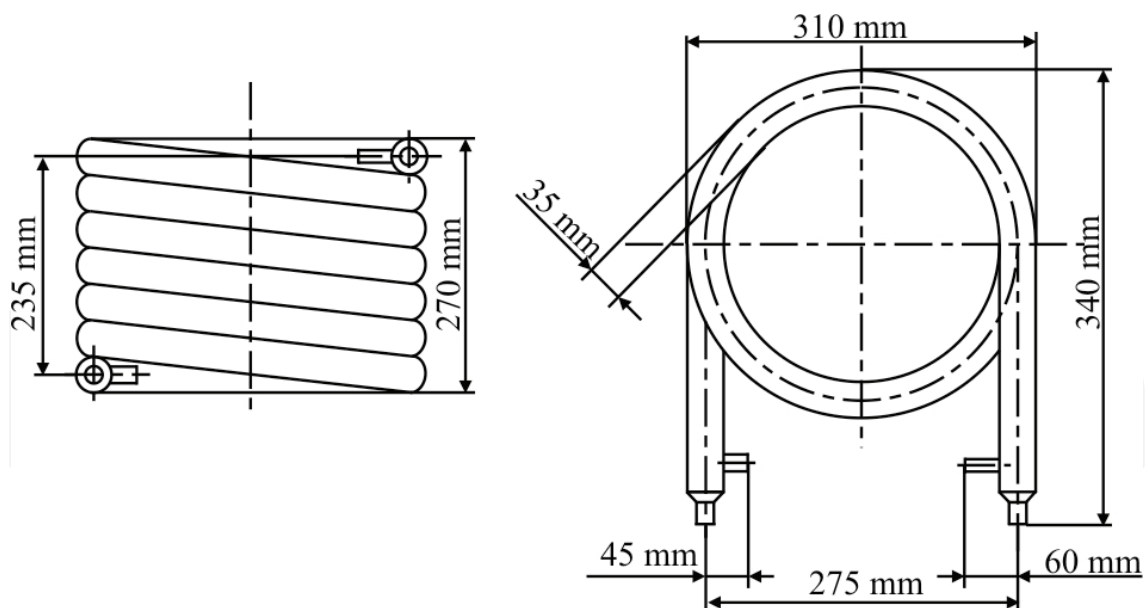

Fig. 2. Schematic of the examined heat exchanger with basic geometry

Coil had a radius of curvature, measured from the centre of the inner tube, of 137.5 mm. Its thermal power Q_n was equal to 14 kW, pressure drop $\Delta p = 0.32$ bar and volumetric flow $V = 2.3$ m³/h. Calculated heat transfer area F_c of the heat exchanger was 0.3952 m². The heat exchanger was very carefully insulated with polyurethane foam to avoid heat losses to the surroundings.

3.3.2 Experimental apparatus

The heat exchanger was tested in the setup presented in Fig. 3. This stand consisted of electrical heater (21.6 kW of thermal power) equipped with circulating pump and expansion vessel, hydraulic couple and examined helically coiled tube-in-tube heat exchanger (Fig. 2).

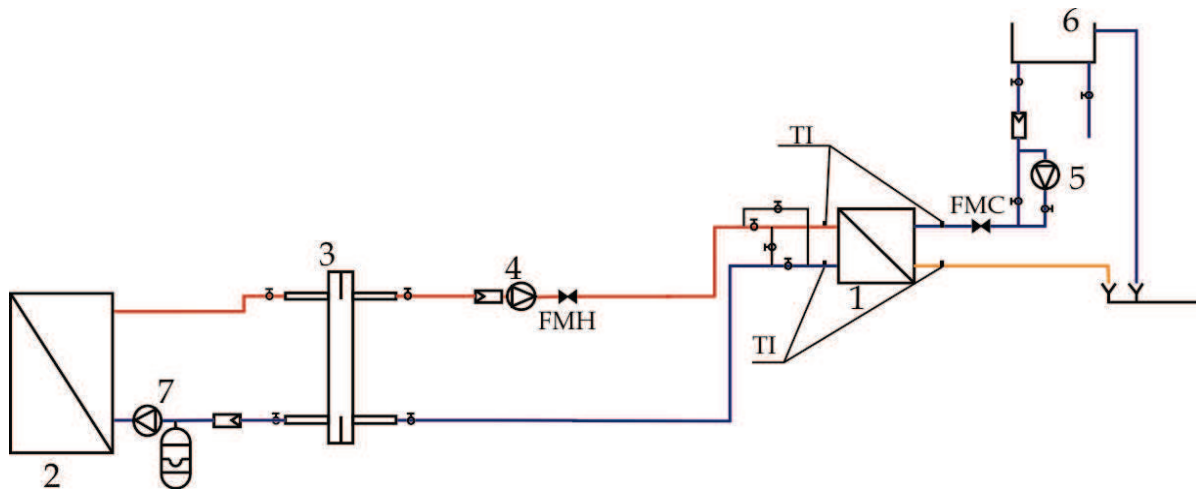

Fig. 3. Diagram of the experimental setup; 1 - helically coiled heat exchanger, 2 -water heater, 3 - hydraulic couple, 4 - circulating pump, 5 - coolant circulating pump, 6 - cold feed water tank, 7 - boiler circulating pump, FMH - hot water flowmeter, FMC - cooling water flowmeter, TI - temperature sensors

Hydraulic couple divided hydraulic system into two independent circuits - heater's and heat sink's. In heat sink circuit, which consisted of hydraulic couple and heat exchanger hot water flow was forced by circulating pump. Nominal volumetric flow of the hot water through the pump was equal to 1.8 m³/h and maximum head 2 m. Circulating pump of the same type was used to pump mains cold water through annular tube of heat exchanger. To provide steady flow of cooling water through the heat exchanger a compensation vessel was mounted on the wall at a height of 2 m. The inlet and outlet temperatures of the hot and cold water were measured using precalibrated K-type thermocouples with high accuracy. The flow of hot water in channel of circular cross-section was controlled by axial turbine flowmeter allowing flows to be measured between 2 and 40 l/min. The flow rate of cold water in annular cross-section channel was controlled by an identical flowmeter. All the fluids properties were assessed at the arithmetic mean temperature of the fluids (average of inlet and outlet temperatures). Temperature and flow data was recorded using a data acquisition system connected to a computer.

3.3.3 Experimental procedure

Volumetric flow rate of the cold water, in the annulus, was kept on constant level, while hot water volumetric flow, in the inner tube of circular cross-section, was varied. The range of hot water flow rates from 3.33 l/min to 20 l/min and cold water from 4 l/min to 8 l/min were used. All possible combinations of these flow rates in both the annulus and the inner tube were examined. These were done for both coils, and in parallel-flow and counter-flow configurations. Temperature data was recorded every one second. For further numerical calculations only results of measurements after the temperatures achieved steady values were taken. Next, experimental data were used for simultaneous calculations of constants

and exponents in heat transfer correlation formulas for Nusselt number on both sides of heat transfer surface.

3.4 Results

Investigations of helically coiled tube-in-tube heat exchanger were conducted in steady state conditions for wide range of temperature and volumetric flow changes of working fluids. The hot fluid, in the channel with circular cross-section, flows in turbulent regime. It was assumed that in this case the dependence for Nusselt number formula will be described by equation shown below (Rogers & Mayhew, 1964; Hewitt, 1994):

$$Nu_1 = \left(1 + 3.5 \frac{d_{1in}}{D}\right) 0.023 Re_1^{0.8} Pr_1^{0.333}, \quad (34)$$

where d_{1in} - denotes inner diameter of the tube with circular cross-section, m; $D = 2R$ - heat exchanger coil mean diameter, m.

While in the case of laminar flow in annular channel the formula for Nusselt number has the following form (Schmidt, 1967):

$$Nu_2 = \left(1 + 3.5 \cdot \frac{d_h}{D}\right) \cdot \left[3.66 + 1.2 \cdot \left(\frac{d_1}{d_{2in}}\right)^{-0.8} + 1.6 \cdot \left(Re_2 \cdot Pr_2 \cdot \frac{d_h}{L}\right)^{0.33} \right], \quad (35)$$

where d_h - denotes equivalent diameter of the annular channel, m; d_1 - outer diameter of the tube with circular cross-section, m; d_{2in} - inner diameter of the tube with annular cross-section, m; L - total length of the heat exchanger.

In Eqs. (34) and (35) components $(1+3.5 \cdot (d_{1in}/D))$ and $(1+3.5 \cdot (d_h/D))$ takes into account the geometry of the helically coiled tube-in-tube heat exchanger. Expression $(3.66+1.2 \cdot (d_1/d_{2in})^{-0.8})$ is a correction for fluid flow in annular channel in examined heat exchanger.

It was assumed that in the first stage of calculation the unknown parameters on the left side of the Reynolds number in equation (34) and (35) will be searched for. All calculations will be carried out on the both sides of the heat transfer surface simultaneously. After taking into consideration the unknown parameters the formulas mentioned above have the form:

$$Nu_1 = \left(1 + 3.5 \cdot \frac{d_{1in}}{D}\right) \cdot A_1 \cdot Re_1^{0.8} Pr_1^{0.33} \quad (36)$$

and

$$Nu_2 = \left(1 + 3.5 \cdot \frac{d_h}{D}\right) \cdot \left[3.66 + 1.2 \cdot \left(\frac{d_1}{d_{2in}}\right)^{-0.8} + A_2 \cdot \left(Re_2 \cdot Pr_2 \cdot \frac{d_h}{L}\right)^{0.33} \right]. \quad (37)$$

The values of unknown parameters A_1 and A_2 (Table 1) were obtained as a result of the performed calculations. And next were used for drawing distributions of the Nusselt number as a function of Reynolds number for hot and cold fluid in counter flow (Fig. 4a) and parallel flow (Fig. 4b).

Changes of Nusselt number in circular channel, expressed by formula (34) and Eq. (35) are very much the same for both arrangement of helically coiled tube-in-tube heat exchanger as

it is shown in Fig. 4. In the following, Eq. (34) will be used for the calculation of the Nusselt number in the circular duct.

Flow type in helically coiled tube-in-tube heat exchanger	
Parallel flow	Counter flow
Equation (36)	
$A_1 = 0.0202$	$A_1 = 0.0188$
Equation (37)	
$A_2 = 30.2301$	$A_2 = 61.8249$

Table 1. Values of the constants in Eq. (36) and Eq. (37) calculated with Levenberg-Marquardt method

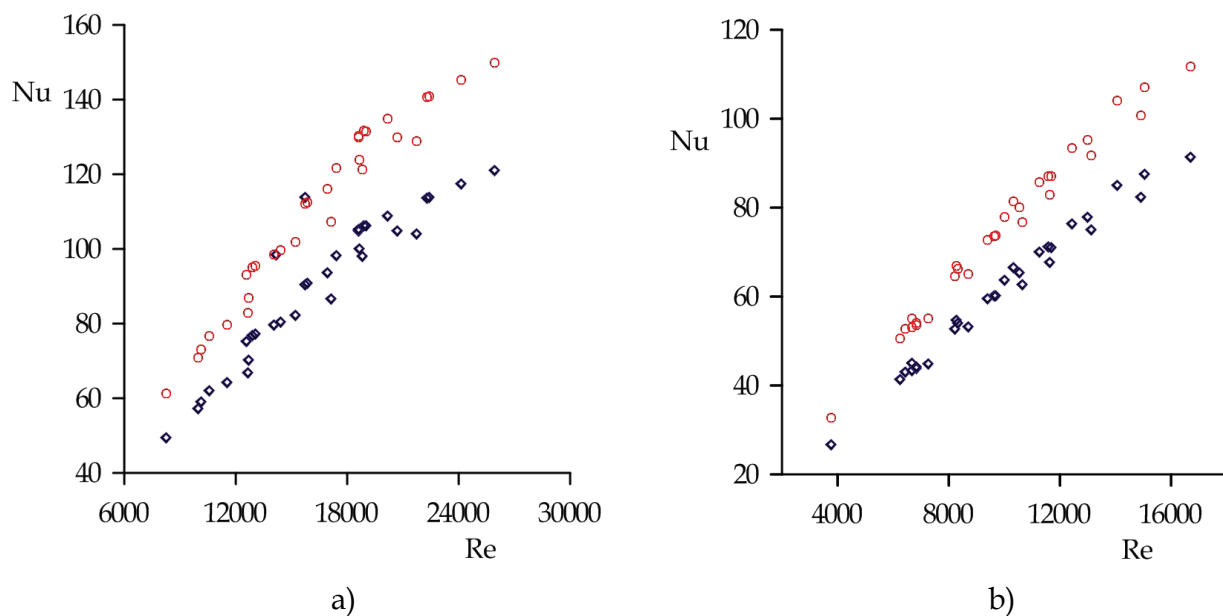

Fig. 4. Distribution of the Nusselt number as a function of Reynolds number in circular channel of the helically coiled tube-in-tube heat exchanger; a) parallel-flow, b) counterflow; \circ Eq. (34), \diamond Eq. (36)

For next stage of calculations Eq. (34) and (35) were modified. Constant A_i and exponent B_i , where $i = 1, 2$ of Reynolds number were investigated in this case.

$$Nu_1 = \left(1 + 3.5 \cdot \frac{d_{1in}}{D}\right) \cdot A_1 \cdot Re_1^{B_1} Pr_1^{0.33} \quad (38)$$

and

$$Nu_2 = \left(1 + 3.5 \frac{d_h}{D}\right) \cdot \left[3.66 + 1.2 \cdot \left(\frac{d_1}{d_{2in}}\right)^{-0.8} + A_2 \cdot \left(Re_2 \cdot Pr_2 \cdot \frac{d_h}{L}\right)^{B_2} \right] \quad (39)$$

As a first constant A_2 in formula (39) for Nusselt number in annular channel for parallel flow in examined heat exchanger was determined and then constant A_2 and exponent B_2

simultaneously. During the calculations the flow in circular channel was described by formula (34).

Identical calculations were carried out for Eq. (38), which was modified in order to adapt it to describe heat transfer in annular channel:

$$Nu_1 = \left(1 + 3.5 \cdot \frac{d_h}{D}\right) \cdot A_1 \cdot Re_1^{B_1} Pr_1^{0.33} \tag{40}$$

Also in this case as a first was calculated constant A_1 , and next constant A_1 and exponent B_1 in Eq. (40).

This procedure was to test, which of the equations will be better to map the set of experimental data of the working fluid in annular channel - less complicated and correct in case of turbulent flow - Eq. (34) or Eq. (35) describing the heat transfer for fluid flow in laminar range.

$Nu_2 = (1 + 3.5 \cdot d_h/D) \cdot [3.66 + 1.2 \cdot (d_1/d_{2in})^{-0.8} + A_2 \cdot (Re_2 \cdot Pr_2 \cdot d_h/L)^{B_2}]$	
$A_2 = 19.7433$	
$A_2 = 3.5754$	$B_2 = 0.8229$
$Nu_1 = (1 + 3.5 \cdot d_h/D) \cdot A_1 \cdot Re_1^{B_1} Pr_1^{0.33}$	
$A_1 = 0.0566$	
$A_1 = 0.0269$	$B_1 = 0.8926$

Table 2. Values of constant and exponents calculated with Levenberg-Marquardt for parallel flow in helically coiled tube-in-tube heat exchanger

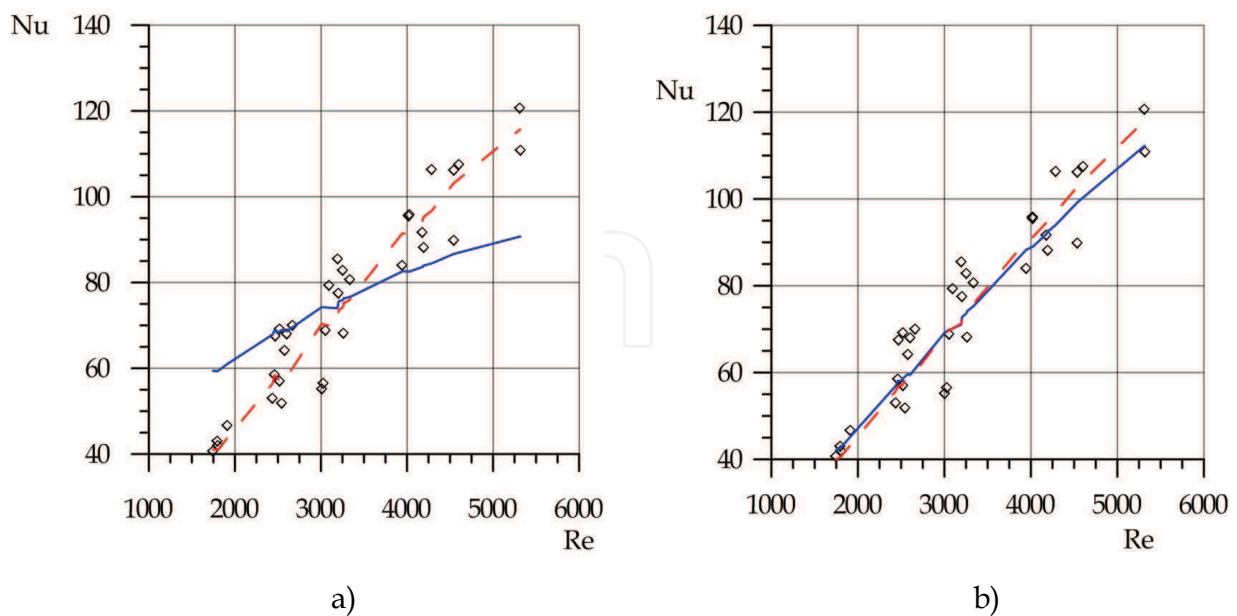

Fig. 5. Comparison of Nusselt number changes in annular channel (parallel flow) for Eqs. (39) and (40). Using Levenberg-Marquardt method was determined: a) one coefficient — and b) two coefficients - - -, experimental points \diamond

In case when examined helically coiled tube-in-tube heat exchanger was working as a counter flow analogous calculations, using least squares method with modified Levenberg-Marquardt, were carried out to determine constants and exponents in correlation formulas for Nusselt number. Results are shown in Table 3 – forms of correlation formulas and determined values of the constants and exponents. Fig. 6. shows changes of two different formulas for Nusselt number as a function of Reynolds number in annular channel. Also in this case as a first was determined value of a constant, and as a second value of constant and exponent.

$Nu_2 = (1 + 3.5 \cdot d_h/D) \cdot \left[3.66 + 1.2 \cdot (d_1/d_{2in})^{-0.8} + A_2 \cdot (\text{Re}_2 \cdot \text{Pr}_2 \cdot d_h/L)^{B_2} \right]$	
$A_2 = 25.397$	
$A_2 = 14.1959$	$B_2 = 0.4997$
$Nu_1 = (1 + 3.5 \cdot d_h/D) \cdot A_1 \cdot \text{Re}_1^{B_1} \text{Pr}_1^{0.33}$	
$A_1 = 0.0827$	
$A_1 = 0.3787$	$B_1 = 0.6052$

Table 3. Values of constant and exponents calculated with Levenberg-Marquardt for counter flow in helically coiled tube-in-tube heat exchanger

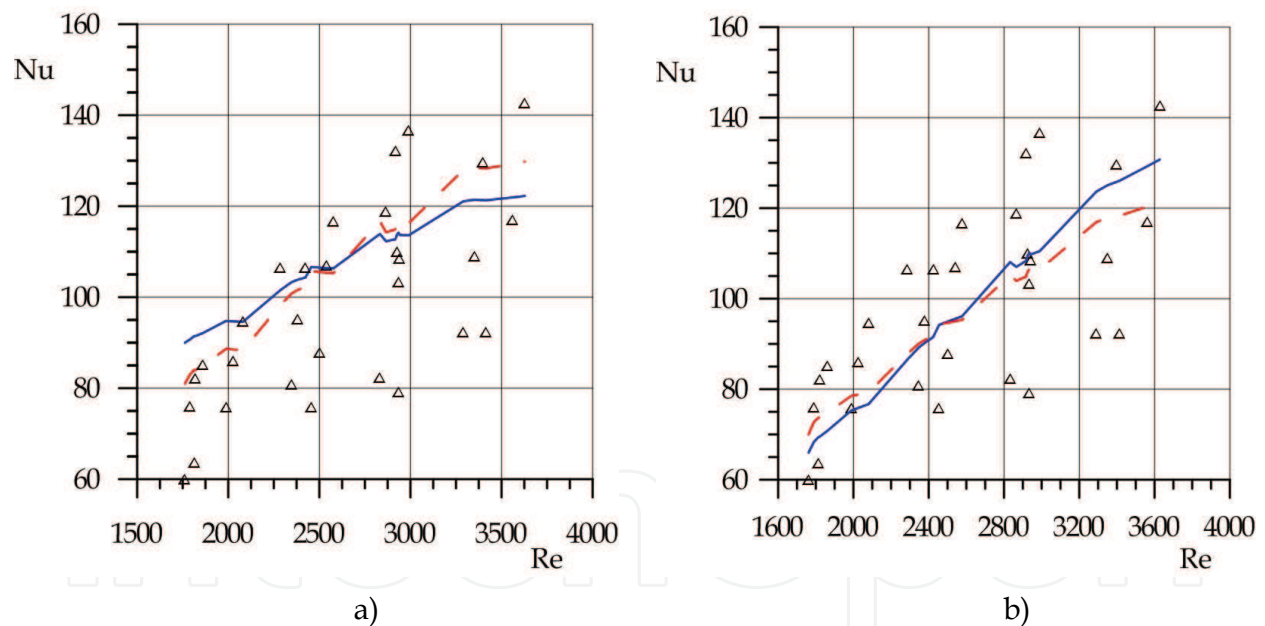

Fig. 6. Comparison of Nusselt number changes in annular channel (counter flow) for Eqs. (38) and (39). Using Levenberg-Marquardt method was determined: a) one coefficient — and b) two coefficients — — —, experimental points Δ

Analyzing changes of the Nusselt number in annular channel (hot fluid) shown on the Fig. 5a and Fig. 6a, drawn as dotted line, the best fit curves to experimental points can be noticed when the Levenberg-Marquardt method is used to determine values of two unknown parameters – constant and exponent in Eq. (39) than in case where only value of the one parameter was investigated.

The differences between calculated values of constants and exponents in heat transfer correlation formulas for counterflow and parallel-flow configuration of the examined heat exchanger are result of the larger average temperature difference between the two fluids. Comparison of the Nusselt number changes with calculated one and two unknown parameters for turbulent (40) and laminar (39) form of the Nusselt formula leads to the conclusion that Eq. (40) better describes the kind of the fluid flows in annular channel for heat exchanger operating in parallel and counter flow.

4. Conclusion

In this paper methodology which allows for numerical determination unknown parameters in correlation formulas for Nusselt number and heat transfer coefficients on the hot and cold fluid side simultaneously was presented. Calculations were carried out on the basis of gathered experimental data for parallel and counter flow of working fluid in helically coiled tube-in-tube heat exchanger. The changes of Nusselt number in circular channel (turbulent flow) and annular channel (laminar flow) as a function of Reynolds number were presented also.

Described methodology for determining constants and exponents in correlation formulas for Nusselt number can be used in designing of the different heat exchangers types and shapes of heat transfer surface.

5. References

- Beck, J. V.; Blackwell, B.; Clair, Ch. R. St. (1985). *Inverse Heat Conduction. Ill-posed Problems*. John Wiley & Sons, ISBN 0-47-108319-4, New York, USA
- Dean W.R. (1928). The Streamline Motion of Fluid in a Curved Pipe (second paper), *Philos. Mag.*, Vol. 7, pp. 673–695, ISSN 1941-5982
- Dean, W.R. (1927). Note on the Motion of Fluid in a Curved Pipe, *Philos. Mag.*, Vol. 4, pp. 208–223, ISSN 1941-5982
- Fernández-Seara, J.; Uhía F.J.; Sieres, J.; Campo, A. (2007). A General Review of the Wilson Plot Method and its Modifications to Determine Convection Coefficients in Heat Exchange Devices. *Applied Thermal Engineering*, Vol.27, pp. 2745–2757, ISSN 1359-4311
- Hewitt, G.F.; Shires, G.L.; Bott T.R. (1994). *Process Heat Transfer*. Begell House Publishers, ISBN 0-8493-9918-1, New York, USA
- Holman, J.P. (2009). *Heat Transfer*. McGraw-Hill, ISBN 0-07-114320-3, New York, USA
- Ito, H. (1959). Friction factors for turbulent flow in curved pipes, *Transactions of ASME D 81*, pp. 123-132, ISSN 0021-9223
- Kumar, R.; Varma, H.K.; Agrawal, K.N.; Mohanty, B. (2001). A Comprehensive Study of Modified Wilson Plot Technique to Determine the Heat Transfer Coefficient During Condensation of Steam and R-134a Over Single Horizontal Plain and Finned Tubes. *Heat Transfer Engineering*, Vol.22, pp.3–12, ISSN 0145-7632
- Kumar, V.; Faizee, B.; Mridha, M.; Nigam, K.D.P. (2008). Numerical Studies of a Tube-in-Tube Helically Coiled Heat Exchanger. *Chemical Engineering and Processing*, Vol.47, pp. 2287–2295, ISSN 0255-2701
- Kuppan, T. (2000). *Heat Exchanger Design Handbook*, Marcel Dekker, Inc, ISBN 0-8247-9787-6, New York, USA
- Lawson, C.; Hanson R. (1995). *Solving Least Squares Problems*, ISBN 0-89871-356-0, Prentice Hall, Englewood Cliffs, USA

- Manglik, R.M. (2003). Heat Transfer Enhancement, In: *Heat Transfer Textbook*, A. Bejan and Kraus A.D., (Eds.), John Wiley & Sons, ISBN 0-471-39015-1, New York, USA
- Nashchokin, V.V. (1980). *Engineering Thermodynamics and Heat Transfer*, Central Books Ltd, ISBN 0-71-471523-9, London, Great Britain
- Pitts, D.R.; Sissom, L.E. (1998). *Shaum's Outline of Theory and Problems of Heat Transfer*. McGraw-Hill, ISBN 0-07-050207-2, New York, USA
- Press, W.H.; Teukolsky, S.A.; Vetterling W.T.; Flannery B.P. (1996). *Numerical Recipes in Fortran 77: The Art of Scientific Computing*. Cambridge University Press, ISBN 0-521-43064-X, New York, USA
- Rennie, T.J.; Raghavan, V.G.S. (2006). Effect of Fluid Thermal Properties on the Heat Transfer Characteristics in a Double-Pipe Helical Heat Exchanger. *International Journal of Thermal Sciences*, Vol.45, pp. 1158–1165, ISSN 1290-0729
- Rogers, G.F.C.; Mayhew Y. R. (1964). Heat Transfer And Pressure Loss In Helically Coiled Tubes With Turbulent Flow. *International Journal of Heat Mass Transfer*, Vol. 7, pp. 1207 – 1216, ISSN 0017-9310
- Rose, J.W. (2004). Heat-Transfer Coefficients, Wilson Plots and Accuracy of Thermal Measurements. *Experimental Thermal and Fluid Science*, Vol.28, pp.77–86, ISSN 0894-1777
- Schmidt, E.F. (1967). Wärmeübergang und Druckverlust in Rohrschlangen. *Chemie Ingenieur - Technik*, 39 Jahrgang, Heft 13, pp. 781 – 789, ISSN 0009-286X
- Seban, R.A.; McLaughlin, E.F. (1963). Heat Transfer in Tube Coils with Laminar and Turbulent Flow. *International Journal of Heat Mass Transfer*, Vol. 6, pp. 387 – 395, ISSN 0017-9310
- Serth, R.W. (2007). *Process Heat Transfer. Principles and Applications*. Academic Press, ISBN 978-0-12-373588-1, Burlington, USA
- Shah, R.K.; Joshi S.D. (1987). Convective Heat Transfer in Curved Ducts, In: *Handbook of Single-Phase Convective Heat Transfer*, S. Kakac, R.K. Shah and W. Aung (Eds.), ISBN 0-47-181702-3, John Wiley & Sons, New York, USA
- Shilling, R.L.; Bell, K.J.; Bernhagen, P.M.; Flynn, T.M.; Goldschmidt, V.M.; Hrnjak, P.S.; Standiford F.C.; Timmerhaus K.D. (1999). Heat-Transfer Equipment, In: *Perry's Chemical Engineers' Handbook*, R.H. Perry and Green D.W., (Eds.), McGraw-Hill, ISBN 0-07-049841-5, New York, USA
- Shokouhmand, H.; Salimpour, M.R., Akhavan-Behabadi, M.A. (2008). Experimental Investigation of Shell and Coiled Tube Heat Exchangers Using Wilson Plots. *International Communications in Heat and Mass Transfer*, Vol.35, pp. 84–92, ISSN 0735-1933
- Smith, E. M. (1997). *Thermal Design of Heat Exchangers: A Numerical Approach: Direct Sizing and Stepwise Rating, and Transients*, John Wiley & Sons, ISBN 0-47-001616-7, New York, USA
- Sobota, T. (2011). Determining of Convective Heat Transfer Coefficients in Heat Exchangers Using the Wilson Plot Technique, In: *Thermal and Flow Processes in Large Steam Boilers. Modeling and Monitoring*, J. Taler, (Ed.), ISBN 978-83-01-16479-9, Warszawa, Poland (in Polish)
- Viegas, R.M.C.M.; Rodríguez, M.; Luque, S.; Alvarez, J.R.; Coelho, I.M.; Crespo, J.P.S.G. (1998). Mass Transfer Correlations in Membrane Extraction: Analysis of Wilson-Plot Methodology. *Journal of Membrane Science*, Vol.145, pp.129-142, ISSN 0376-7388
- Visual Numerics Inc. (2007). *IMSL Fortran and C Application Development Tools*, Vol. 1 and 2. Houston, Texas, USA

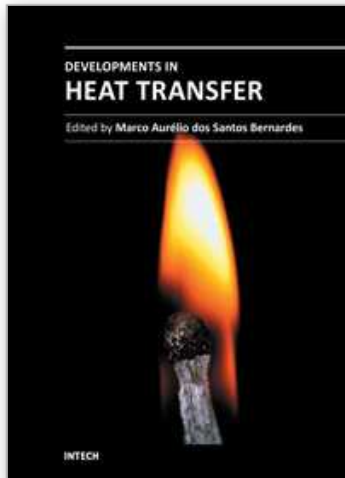

Developments in Heat Transfer

Edited by Dr. Marco Aurelio Dos Santos Bernardes

ISBN 978-953-307-569-3

Hard cover, 688 pages

Publisher InTech

Published online 15, September, 2011

Published in print edition September, 2011

This book comprises heat transfer fundamental concepts and modes (specifically conduction, convection and radiation), bioheat, entransy theory development, micro heat transfer, high temperature applications, turbulent shear flows, mass transfer, heat pipes, design optimization, medical therapies, fiber-optics, heat transfer in surfactant solutions, landmine detection, heat exchangers, radiant floor, packed bed thermal storage systems, inverse space marching method, heat transfer in short slot ducts, freezing and drying mechanisms, variable property effects in heat transfer, heat transfer in electronics and process industries, fission-track thermochronology, combustion, heat transfer in liquid metal flows, human comfort in underground mining, heat transfer on electrical discharge machining and mixing convection. The experimental and theoretical investigations, assessment and enhancement techniques illustrated here aspire to be useful for many researchers, scientists, engineers and graduate students.

How to reference

In order to correctly reference this scholarly work, feel free to copy and paste the following:

Tomasz Sobota (2011). Experimental Prediction of Heat Transfer Correlations in Heat Exchangers, Developments in Heat Transfer, Dr. Marco Aurelio Dos Santos Bernardes (Ed.), ISBN: 978-953-307-569-3, InTech, Available from: <http://www.intechopen.com/books/developments-in-heat-transfer/experimental-prediction-of-heat-transfer-correlations-in-heat-exchangers>

INTECH
open science | open minds

InTech Europe

University Campus STeP Ri
Slavka Krautzeka 83/A
51000 Rijeka, Croatia
Phone: +385 (51) 770 447
Fax: +385 (51) 686 166
www.intechopen.com

InTech China

Unit 405, Office Block, Hotel Equatorial Shanghai
No.65, Yan An Road (West), Shanghai, 200040, China
中国上海市延安西路65号上海国际贵都大饭店办公楼405单元
Phone: +86-21-62489820
Fax: +86-21-62489821

© 2011 The Author(s). Licensee IntechOpen. This chapter is distributed under the terms of the [Creative Commons Attribution-NonCommercial-ShareAlike-3.0 License](#), which permits use, distribution and reproduction for non-commercial purposes, provided the original is properly cited and derivative works building on this content are distributed under the same license.

IntechOpen

IntechOpen